

ASSEMBLY INSTRUCTIONS MANUAL DE MONTAGEM / INSTRUCCIONES DE ARMADO

Reference
Referência
Referencia

| Revise
| Revisão
| Revisión

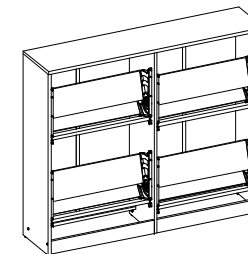

YOU WILL NEED VOCÊ VAI PRECISAR DE / USTED NECESITARÁ

Tools not supplied
Ferramentas não fornecidas / Herramientas no incluidas

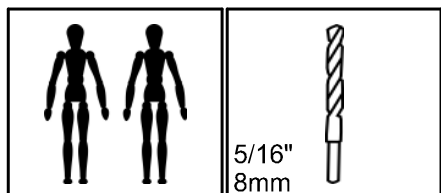

2 People
2 Pessoas
2 Personas

Drill bit
Broca
Taladro

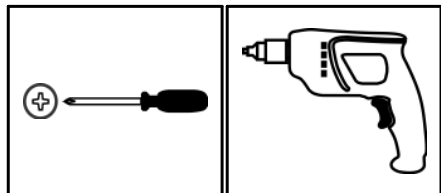

Screwdriver Phillips
Chave Phillips
Destornillador cruz

Drill machine
Furadeira
Taladro

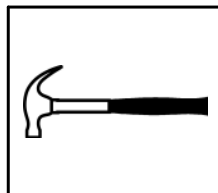

Hammer
Martelo
Martillo

 MAXIMUM RECOMMENDED WEIGHT BEING THIS EVENLY DISTRIBUTED.
PESO MÁXIMO RECOMENDADO SENDO ESTE DISTRIBUÍDO UNIFORMEMENTE.
PESO MÁXIMO RECOMENDADO SIENDO ESTE UNIFORMEMENTE DISTRIBUIDO.

	LB	KG
D	11	5
G	33	15

PARTS IDENTIFICATION IDENTIFICAÇÃO DAS PEÇAS / IDENTIFICACIÓN DE LAS PIEZAS

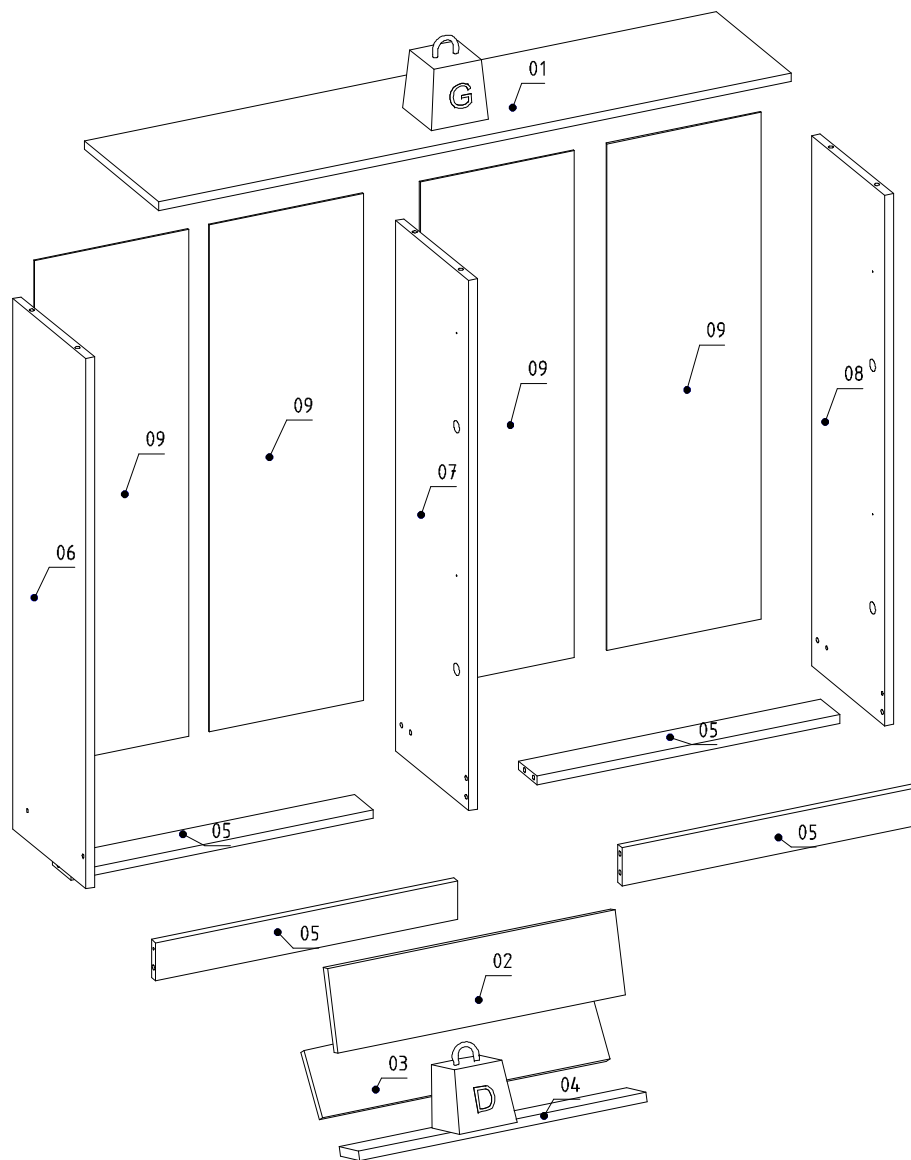

Nº	Measures_Inches	Medidas_cm	Qty./Qtd.
01	43 1/4 x 10 1/4 x 5/8	110.0 x 26.0 x 1.5	1
02	19 5/8 x 5 3/8 x 5/8	50.0 x 13.5 x 1.5	4
03	19 5/8 x 4 3/8 x 5/8	50.0 x 11.0 x 1.5	4
04	19 5/8 x 2 3/4 x 5/8	50.0 x 7.0 x 1.5	4
05	20 3/4 x 2 1/2 x 5/8	52.6 x 6.5 x 1.5	4
06	35 5/8 x 10 x 5/8	90.5 x 25.5 x 1.5	1
07	35 5/8 x 10 x 5/8	90.5 x 25.5 x 1.5	1
08	35 5/8 x 10 x 5/8	90.5 x 25.5 x 1.5	1
09	34 x 10 1/2 x 1/8	86.5 x 26.8 x 0.3	4

IDENTIFICATION OF ACCESSORIES IDENTIFICAÇÃO DOS ACESSÓRIOS/ IDENTIFICACIÓN DE ACCESORIOS



The separation of the accessories before you start the assembly will facilitate the same. In case of doubt on the size of the screws and bolts, use the ruler at the bottom of the page.
 A separação dos acessórios antes de iniciar a montagem facilitará a mesma. Em caso de dúvida no tamanho dos parafusos e cavilhas, utilize a régua ao final da página.
 La separación de los accesorios antes de comenzar el armado facilitará el mismo. En caso de duda sobre el tamaño de los tornillos y taquetes, utilice la regla al pie de página.

A		Flanged head screw Parafuso flangeado / Tornillo de cabeza flangeada	5,0x60 mm	1
A2		Small plastic foot Sapata redonda / Pie plástico	14 mm	6
A4		Metalic bracket Cantoneira de metal / Suporte de metal	22x22 mm	10
A6		"H" profile Perfil "H" / Perfil "H"	-	2
A7		Pan head screw Parafuso panela / Tornillo de pan	5,5x25 mm	8
A8		Flat head screw Parafuso chato / Tornillo de cabeza plana	3,5x20 mm	8
B3		Bushing Bucha expansiva / Tapón	8x50 mm	1
B7		Metalic bracket Suporte de metal / Suporte de metal	-	1
C1		Metal claw Garra de metal / Garra metal	-	5
C9		Pin fastener Pino fixador / Clavija fijador	-	8
D1		Pin suport Pino suporte / Clavija soporte	-	8
D2		Stop pin Batente / Batiente	-	8
E		Wooden dowel Cavilha / Taquete	8x30 mm	10
F		Wooden dowel Cavilha / Taquete	8x50 mm	4
N		Nail Prego / Clavo	10x10	55
O		Flat head screw Parafuso chato / Tornillo de cabeza plana	4,5x45 mm	4
P5		Flat head screw Parafuso chato / Tornillo de cabeza plana	3,5x14 mm	40
S		Pan head screw Parafuso panela / Tornillo de pan	3,5x14 mm	22



PRE-ASSEMBLE PRÉ-MONTAGEM / PRE ARMADO

01

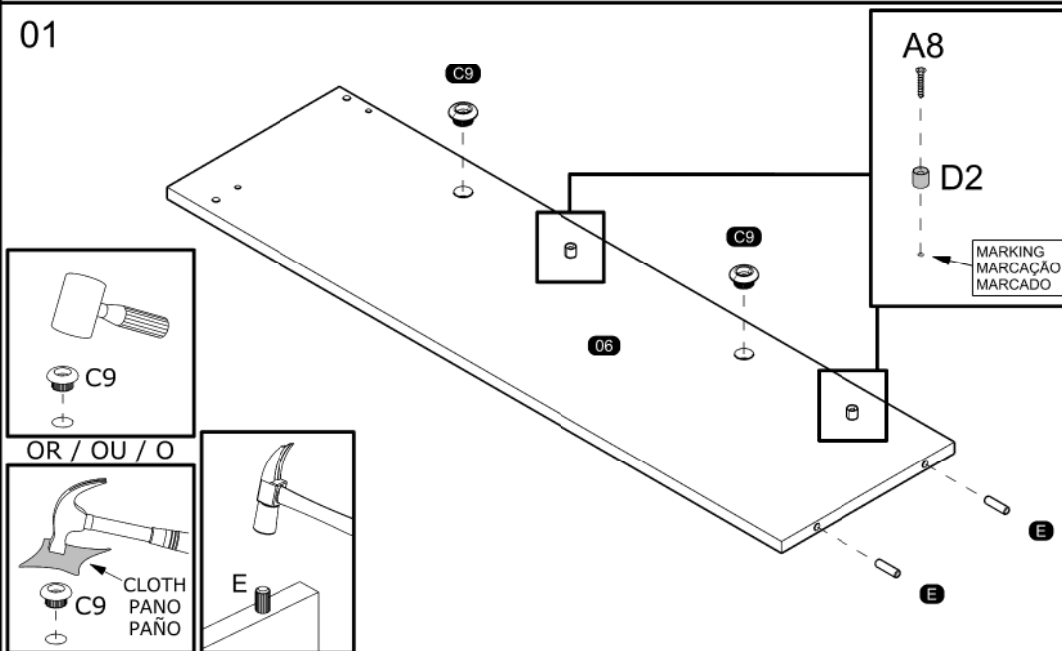

02

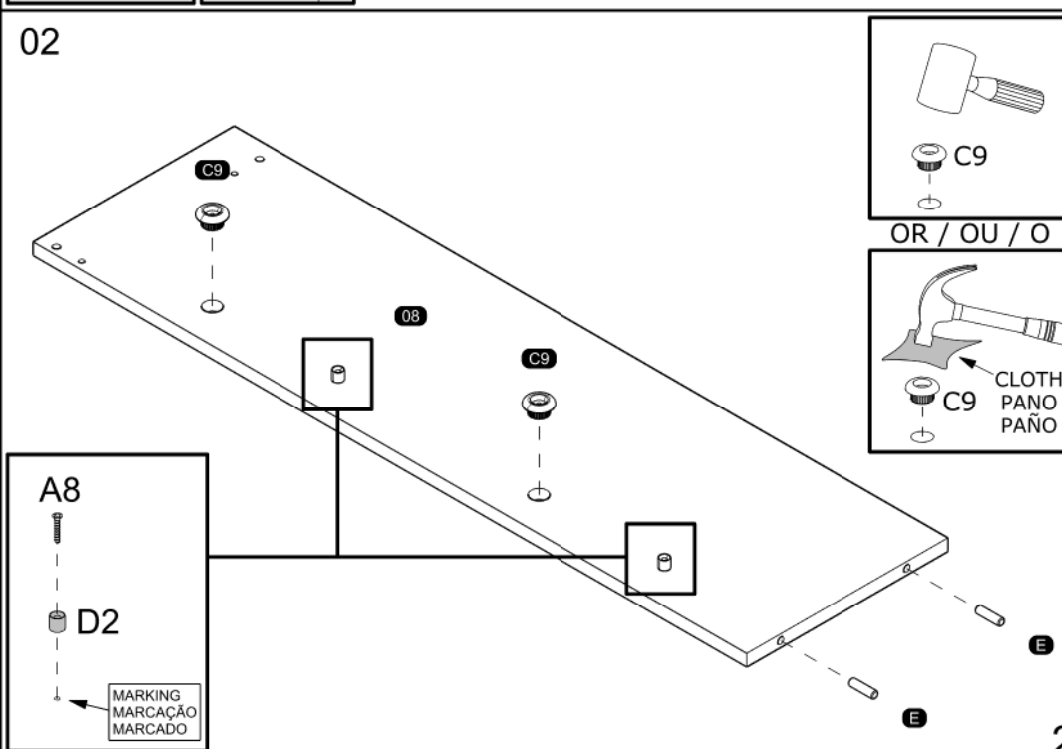

03

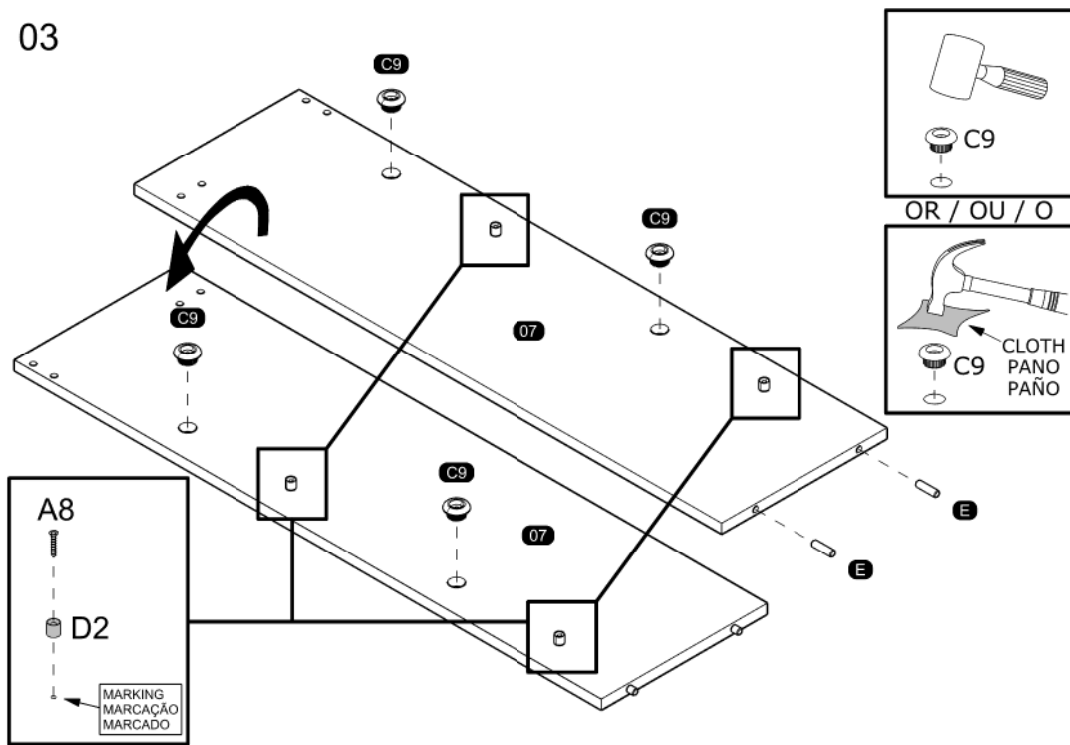

ASSEMBLY MONTAGEM / ARMADO

05

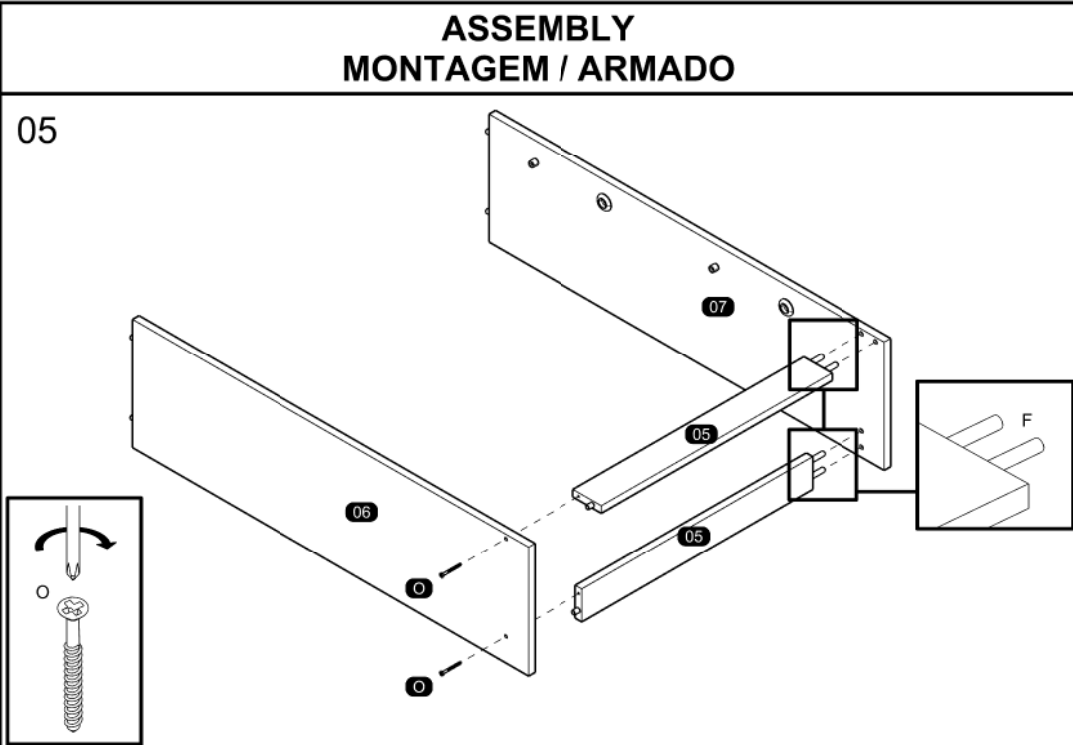

04

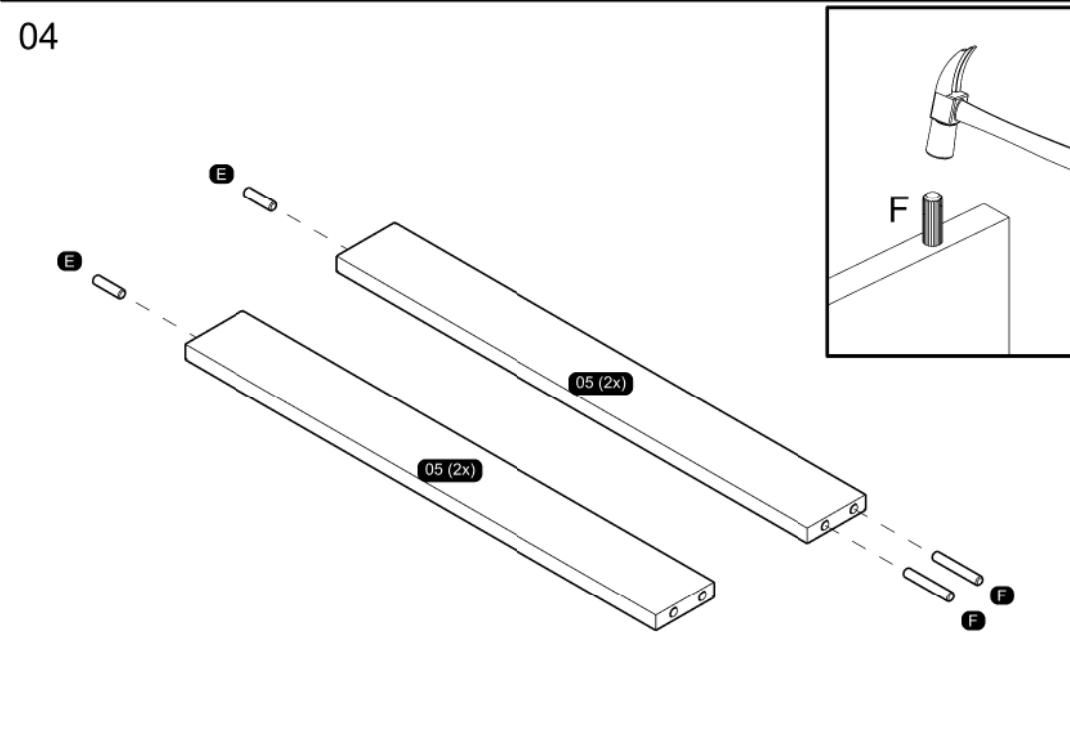

06

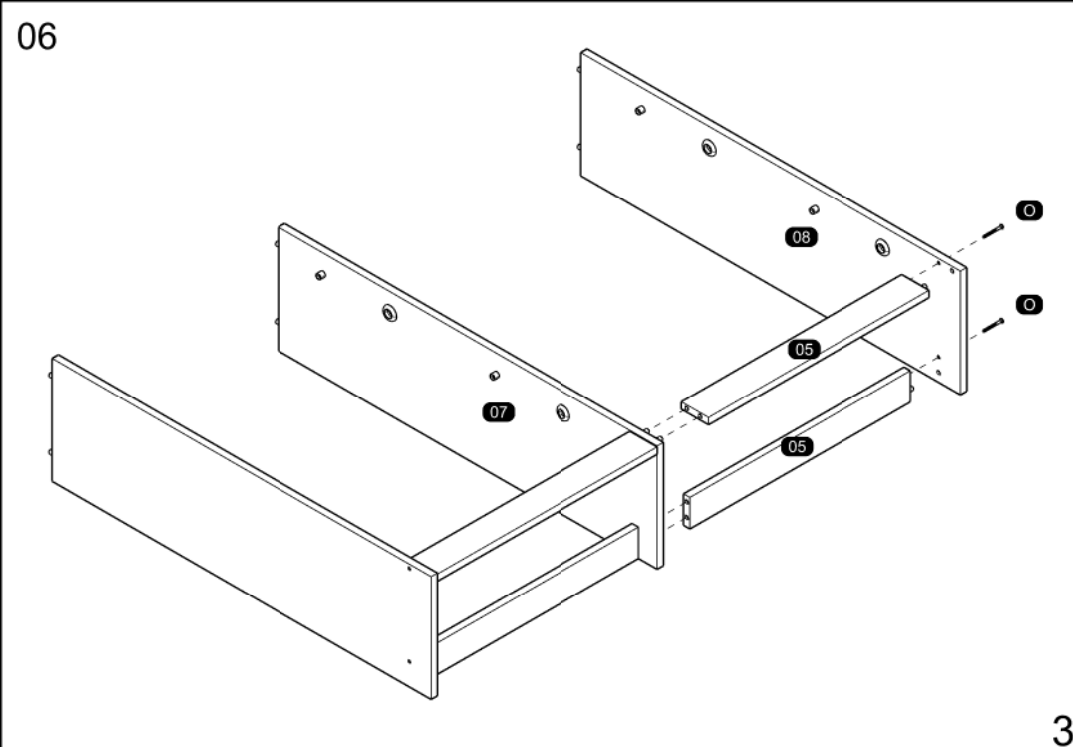

07

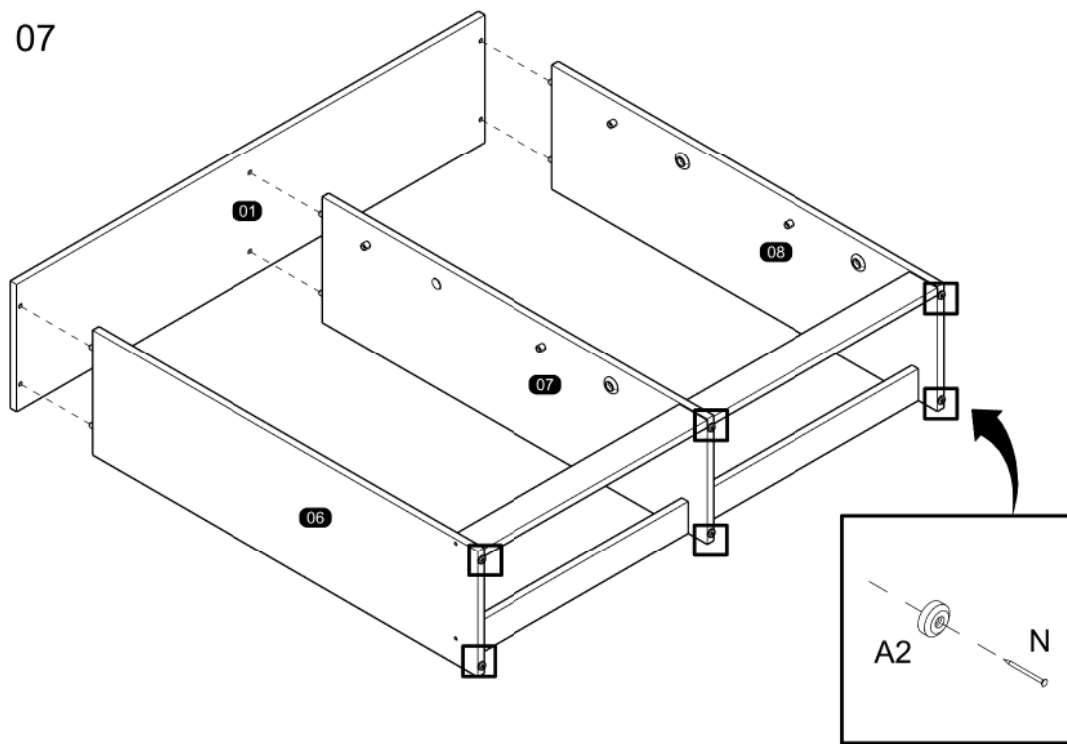

09

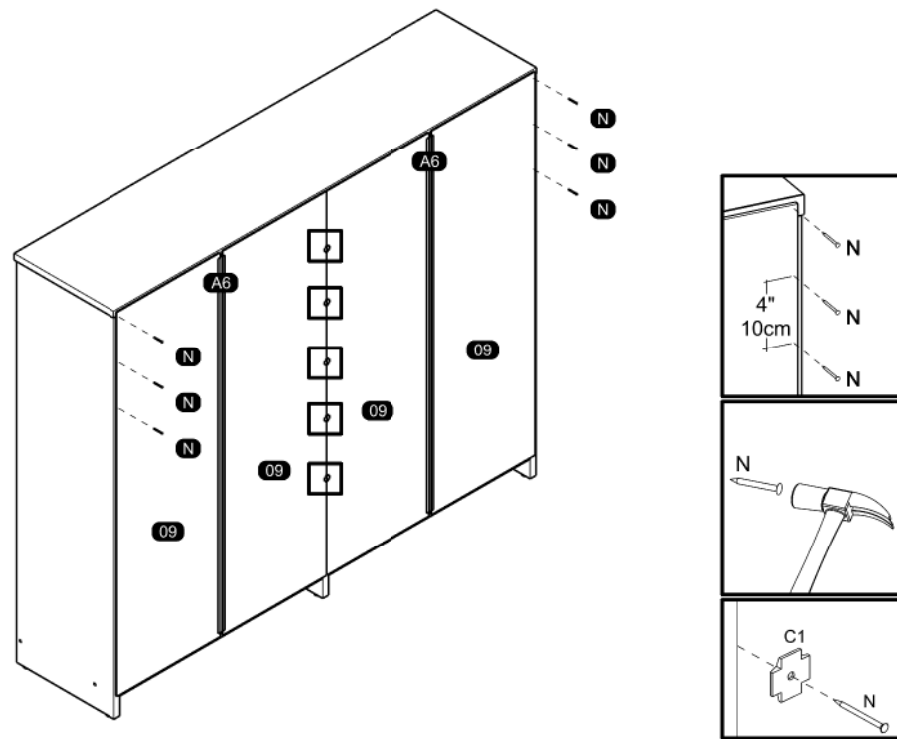

08

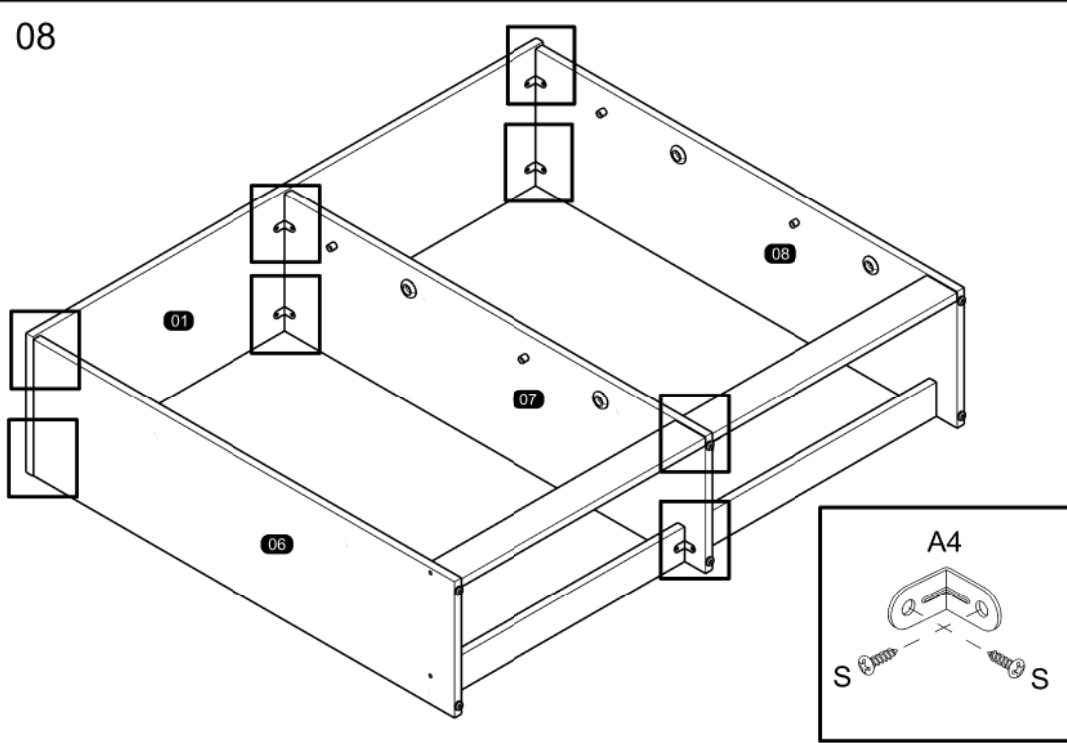

10

