

DIMENSÕES DO PRODUTO / PRODUCT DIMENSIONS / DIMENSIONS PRODUCT - WxDxH / LxPxA - 1800X 388X 560 MM

PEÇAS NUMERADAS / NUMBERED PARTS /
PIEZAS NUMERADAS

EX: 1915X-X 04 (peça/ piece/ pieza number)

TV até 65"

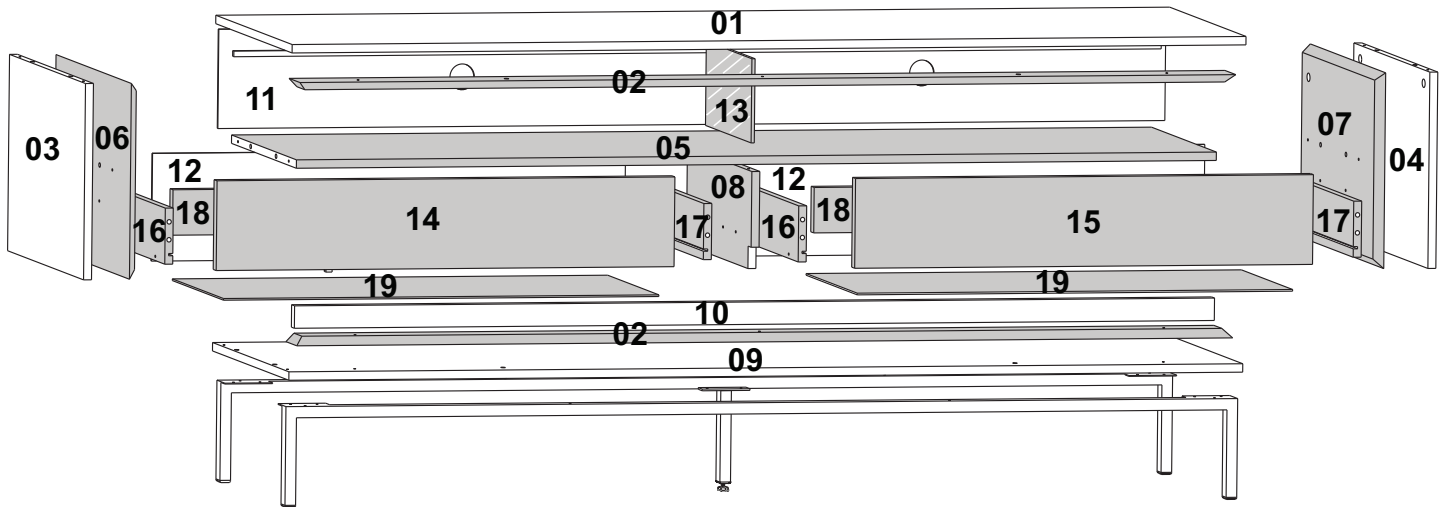
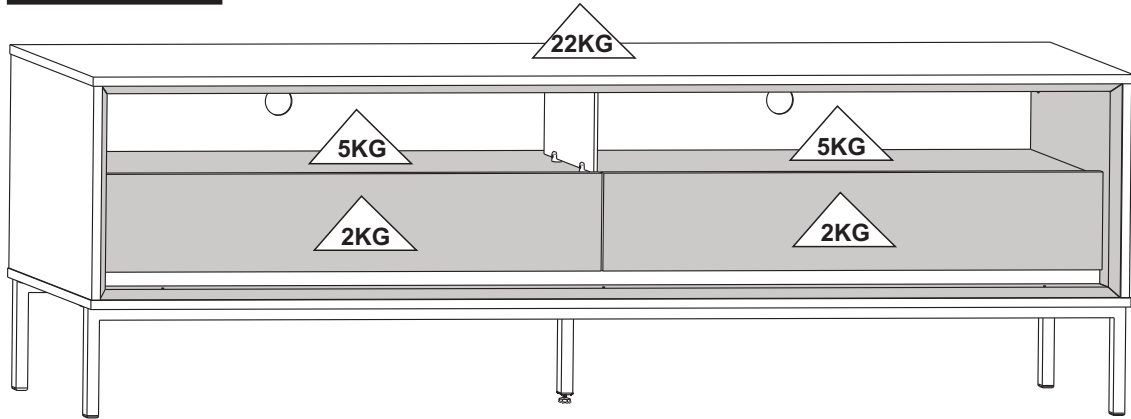

Ferramentas
necessárias /
(não fornecidas)

Necessary tools /
(not provided)

Herramientas
Necesarias
(No proporcionadas)



1



MONTAR O PRODUTO SOBRE A EMBALAGEM,
EVITANDO DANOS NA PINTURA.
ACONSELHAMOS QUE A MONTAGEM DO PRODUTO
SEJA POR UM PROFISSIONAL.

SETUP THE PRODUCT ON TOP OF THE PACKAGING,
AVOIDING DAMAGE TO THE PAINT.
WE RECOMMEND THAT THE INSTALLATION IS DONE BY
A PROFESSIONAL.

MONTAR EL PRODUCTO EN EL PAQUETE,
EVITAR LESIONES EN PINTURA.
AVISAMOS QUE EL MONTAJE DEL PRODUCTO
SEA UN PROFESIONAL.

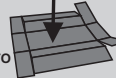

ATENÇÃO / ATTENTION / ATENCION

Nunca utilizar óleos, lustra móveis, produtos abrasivos, saponáceos, esponja de aço e outros.

Never use oils, furniture polish, abrasive products, soaps, steel sponge and others.

Nunca use aceites, pulimentos, abrasivos, jabones, esponja de acero y otros.

CUIDADOS ESPECIAIS/ SPECIAL CARE/ CUIDADOS ESPECIALES

- Evitar expor o móvel ao sol, e em lugares úmidos.
- Limpar com flanela seca ou com pano levemente umedecido em água.
- Avoid exposing the furniture to the sun, and in damp places.
- Clean with dry flannel or lightly cloth moistened with water.
- Evite exponer los muebles al sol y en lugares húmedos.
- Limpiar con flanela seca o un paño ligero, humedecido con agua.

ITEM		DESCRIÇÃO DA PEÇAS / DESCRIPTION OF PARTS / UNIT MEASURE USED IS MILLIMETERS (MM)	CORES/ COLOR/ COLORES					
COD. CODE	Nº	NOME/NAME/NOMBRE	MEDIDAS / MEASURES (MM)	QUANT AMOUNT CANTIDAD	TIPO TYPE	BRANCO / WHITE / BLANCO	PRETO / BLACK / NEGRO	OFF WHITE / CINZA
19428	1	TAMPO/ TOP	1800X385X15	1	MDP		01/07	01/12
19427	2	TAMPO BASE INTERNO/ INTERNAL BASE TOP/	1766X55X15	2	MDF	02/05		02/12
19429	3	LATERAL ESQUERDA/ LEFT SIDE/ LADO IZQUIERDO	383X350X15	1	MDP		03/07	03/12
19430	4	LATERAL DIREITA/ RIGHT SIDE/ LADO DERECHO	383X350X15	1	MDP		04/07	04/12
19423	5	TAMPO NICHOS/ NICHE TOP	1736X327X15	1	MDP	05/05		05/12
19431	6	LATERAL ESQ. INT./ LEFT INTERNAL SIDE/ LADO IZQUIERDO INTERNO	380X349X15	1	MDF	06/06		06/12
19432	7	LATERAL DIR. INT./ RIGHT INTERNAL SIDE/ LADO DERECHO INTERNO	380X349X15	1	MDF	07/07		07/12
19424	8	DIVISOR NICHOS/ DIVIDER/ DIVISOR	325X175X15	1	MDP	08/08		08/12
19425	9	BASE	1800X385X15	1	MDP		09/07	09/12
19426	10	VISTA INF. FRONT./FRONT LAYER VIEW/VISTA INF. DELANTERO	1736X40X15	1	MDP		10/07	10/12
19434	11	FUNDO TRÁS / BACK / TRASEIRO	1787X177X3	1	MDF		11/07	11/12
19433	12	FUNDO TRÁS / BACK / TRASEIRO	892X192X3	2	MDF		12/07	12/12
19227	13	VIDRO/ GLASS/ VIDRIO	230X150X6	1	VIDRO		-----	-----
19435	14	FRENTE GAV. ESQ./ LEFT DRAWER FRONT/ CÁJON DELANTERO IZQUIERDA	864X159X15	1	MDP	14/05		14/12
19436	15	FRENTE GAV. DIR./ RIGHT DRAWER FRONT/ CÁJON DELANTERO DERECHA	864X159X15	1	MDP	15/05		15/12
19437	16	LATERAL GAV ESQ/ LEFT DRAWER SIDE/ LADO CÁJON IZQUIERDO	250X100X15	2	MDP	16/05		16/12
19438	17	LATERAL GAV DIR/ RIGHT DRAWER DIDE/ LADO CÁJON DERECHO	250X100X15	2	MDP	17/05		17/12
19439	18	CONTRA FRENTE/ AGAINST DRAWER FRONT/ CONTA EL FRENTE DEL CÁJON	805X81X15	2	MDP	18/05		18/12
19440	19	FUNDO GAVETA/ DRAWER BACK/ FONDO DEL CÁJON	821X258X3	2	MDF	19/05		19/12
438	A	PF. / Screw / Tornillo 4,0x40 (MM) CH		18				
433	B	PF. / Screw / Tornillo 4,0x20 (MM) CH		10				
986	C	PF./Screw/ Tornillo 3,5x14 (MM) CRR		65				
137	D	Cavilha / Wooden Dowel / Tarugo 8x30 (MM)		24				
2921	E	Cavilha / Wooden Dowel / Tarugo 8x20 (MM)		02				
532	F	Pino Minifix / Minifix Screw 32 (MM)		06				
508	G	Tambor Minifix / Minifix Round Nut 15 (MM)		06				
132	H	Cantoneira Metal/ Angle Metal/ Esquina Metálica 20x20 mm		02				
248	I	Prego / Nail / Clavo 8x8(MM)		40				
911	J	Garra/ Jont Metal Plate/ Embragues		07				
18147	K1/K2	Corrediça Telescópica 250mm (2pares)		2 Pares				
3441	L	Amortecedor/ Pu Bumper/ Parachoques Poliuretanos		04				
340	M1/M2	Suporte de Vidro/ Glass Suport/ Soporte de Vidrio- 16X16 (MM)		04				
15175	N1/N2	Cantoneira Plástica/ Plast. Coner Whit Lid/ Esquina PL. 20X20X42 (MM)		04		CINZA	CINZA	
7687	O	Tapa Furo /Holer Sticker/Tapa Agugero 8 mm		03		BRANCO	BRANCO	
7718						CINZA	CINZA	
19442	P	Pé Metal/ Metal Foot/ Pie Metalico 1796X40X176 MM		02		OURO	PRETO	
18610	Q	Pé Metal Central/ Metal Foot/ Pie Metalico 90X20X166 (MM)		01		OURO	PRETO	
17450	R1/R2	Bucha PL/ Bushing/ Casquillo 20X20 ROSCA 1/4 PP10		01		PRETO	PRETO	
17449		Pé PL. Nom. 12 Nivelador/ Foot/ Pie 1/4 X 3/4 (MM)		01		PRETO	PRETO	
436	S	PF. / Screw / Tornillo 4,0x30 (MM) CH		08				
19242	X	Kit Led- NEON- 1750 (MM)		01				
		Certif. de Garant./ Warranty Certif.		01				

MEDIDA UTILIZADA EM MM / UNIT MEASURE USED IS MILLIMETERS (MM)

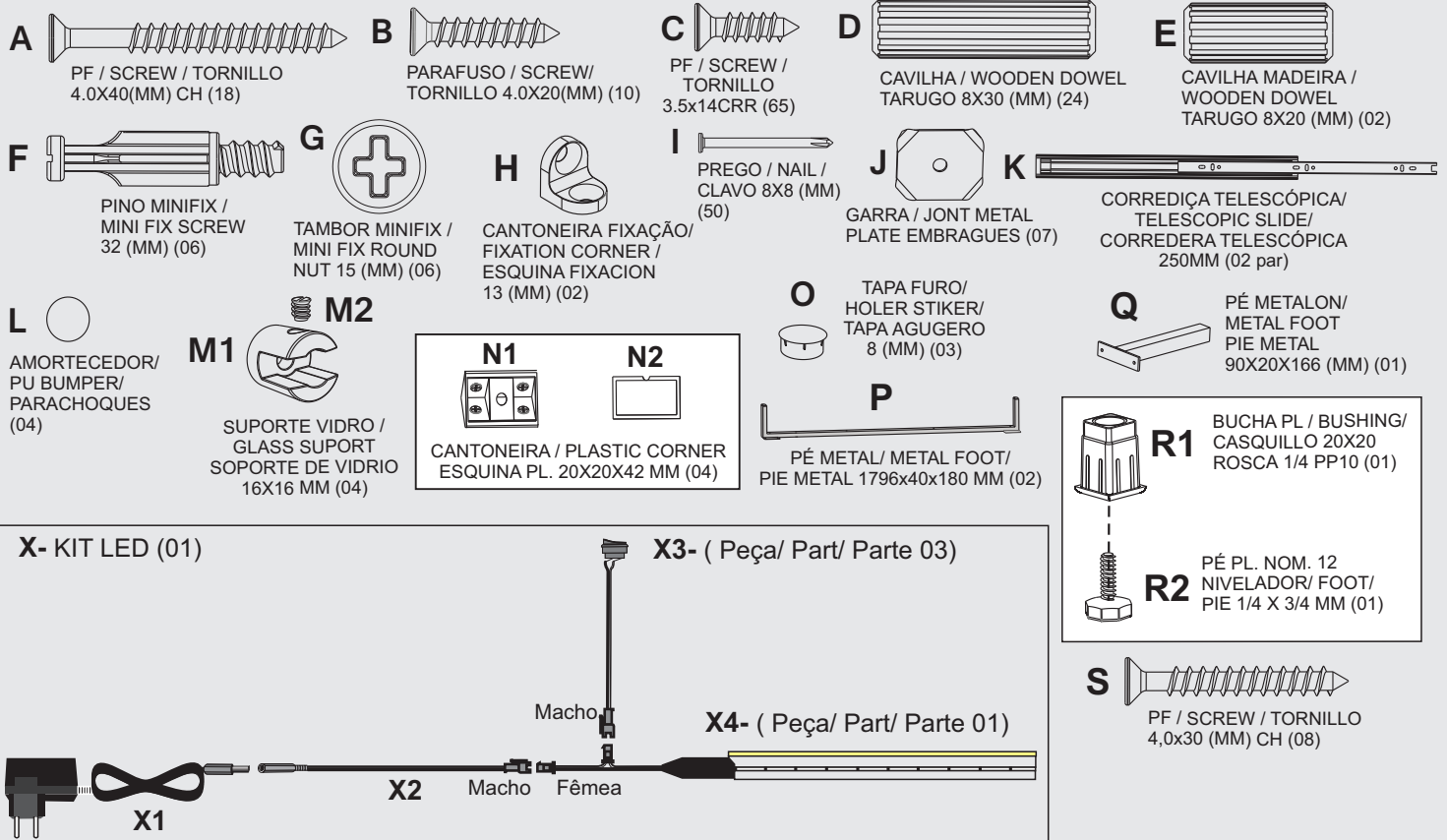

PREPARAÇÃO DE PEÇAS/ PARTS PREPARATION / PREPARACION DE PIEZAS

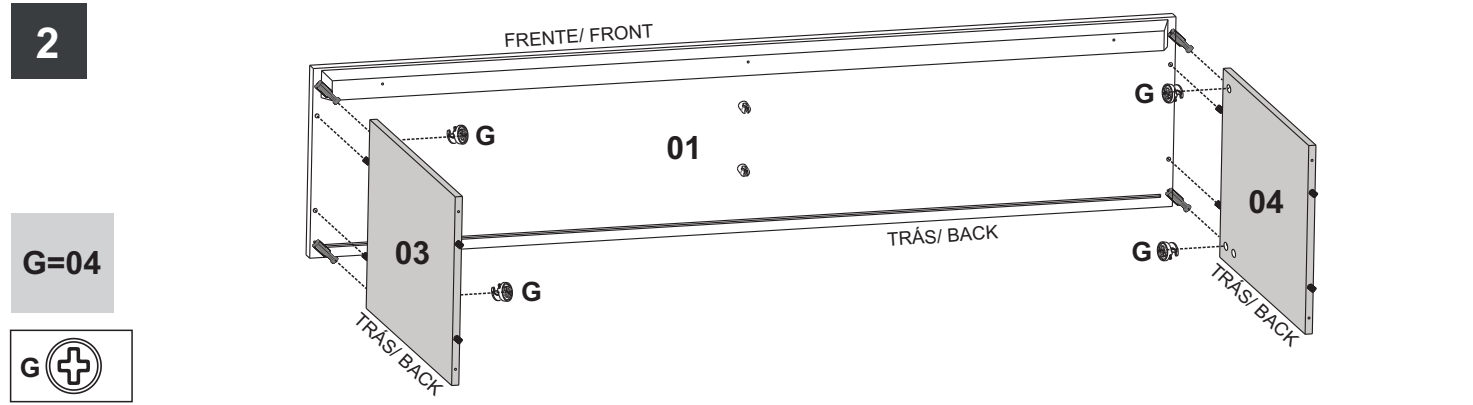
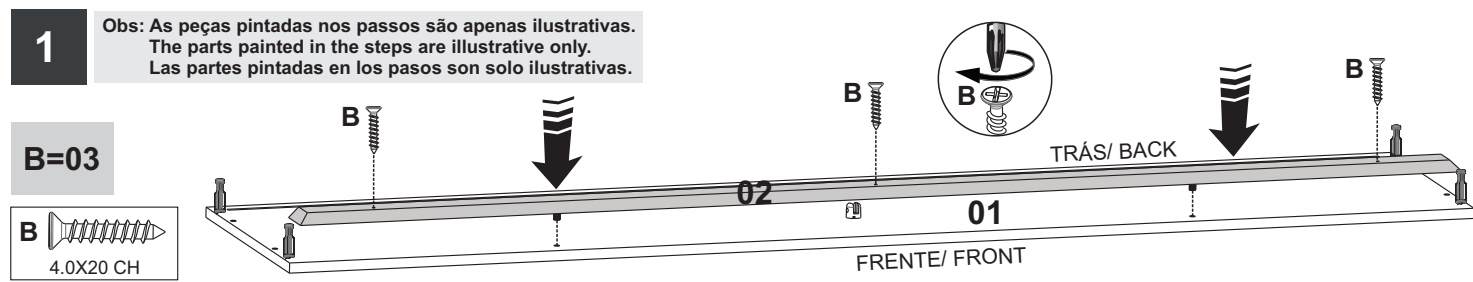
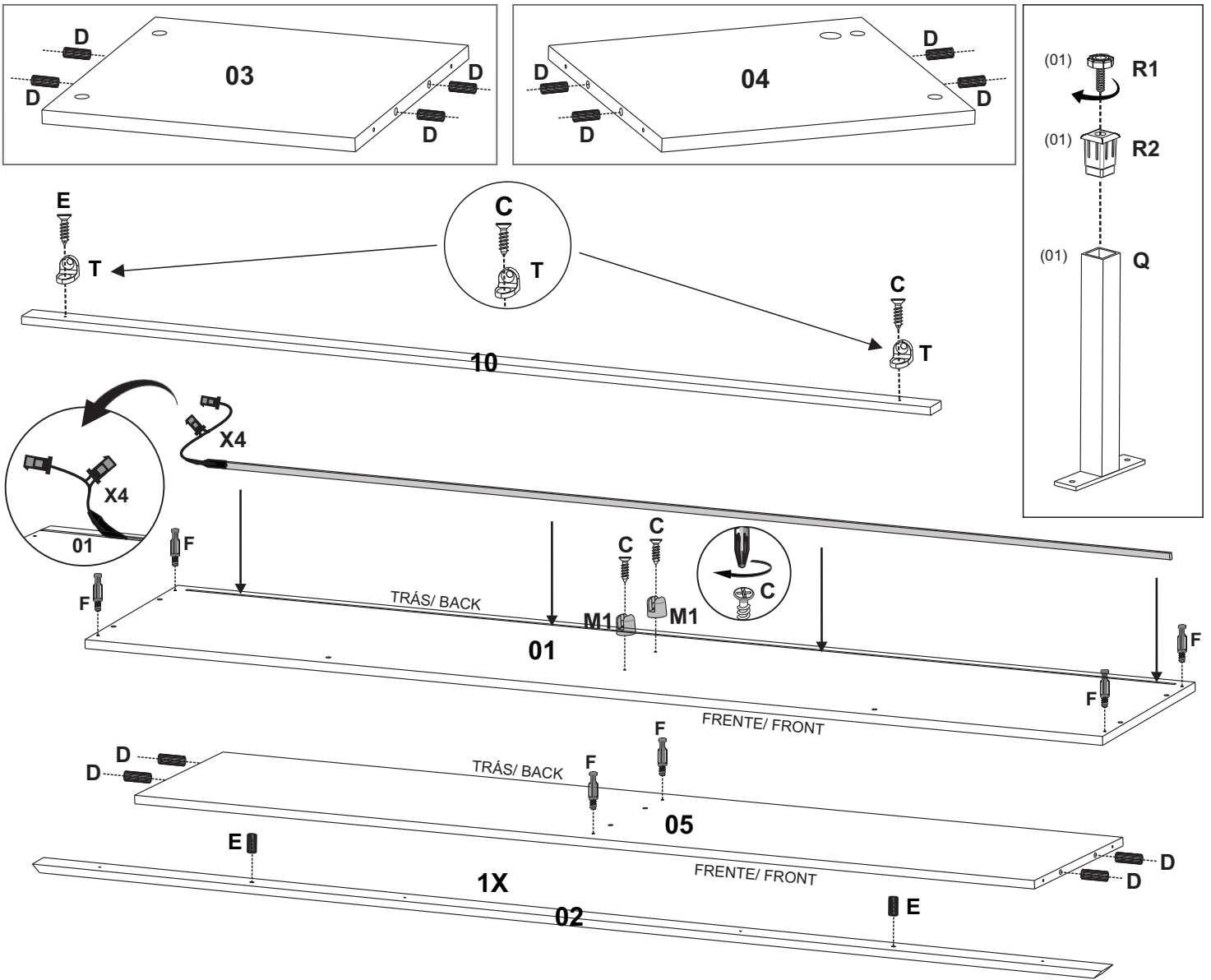
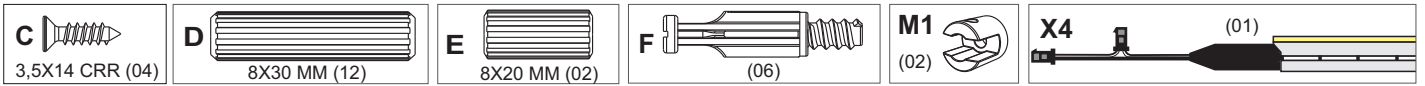

3

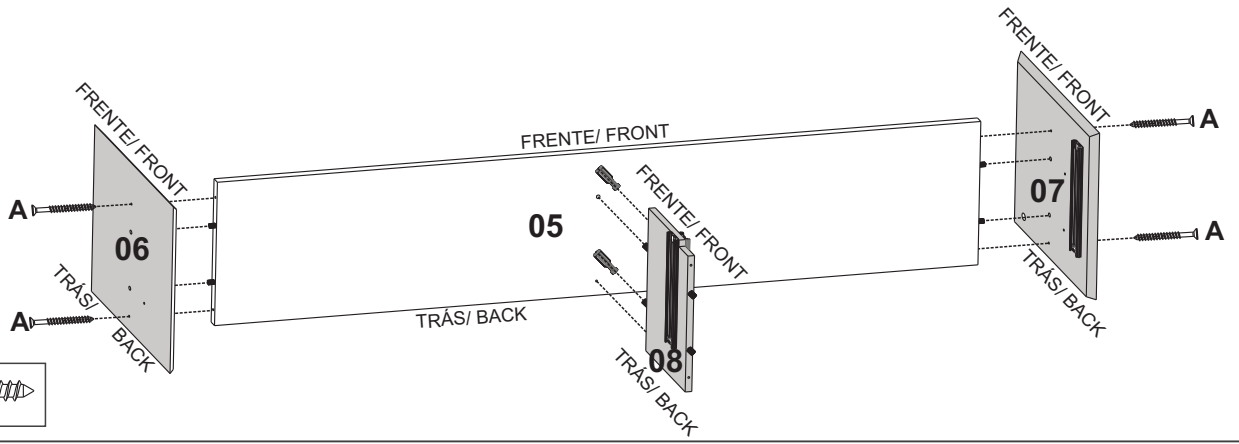

A=04

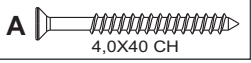

4

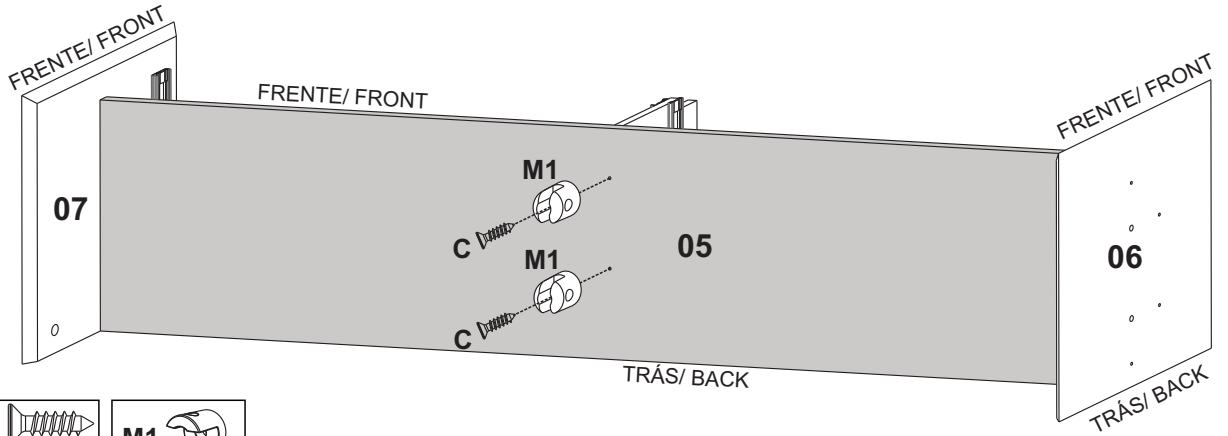

C=02
M1=02

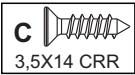

5

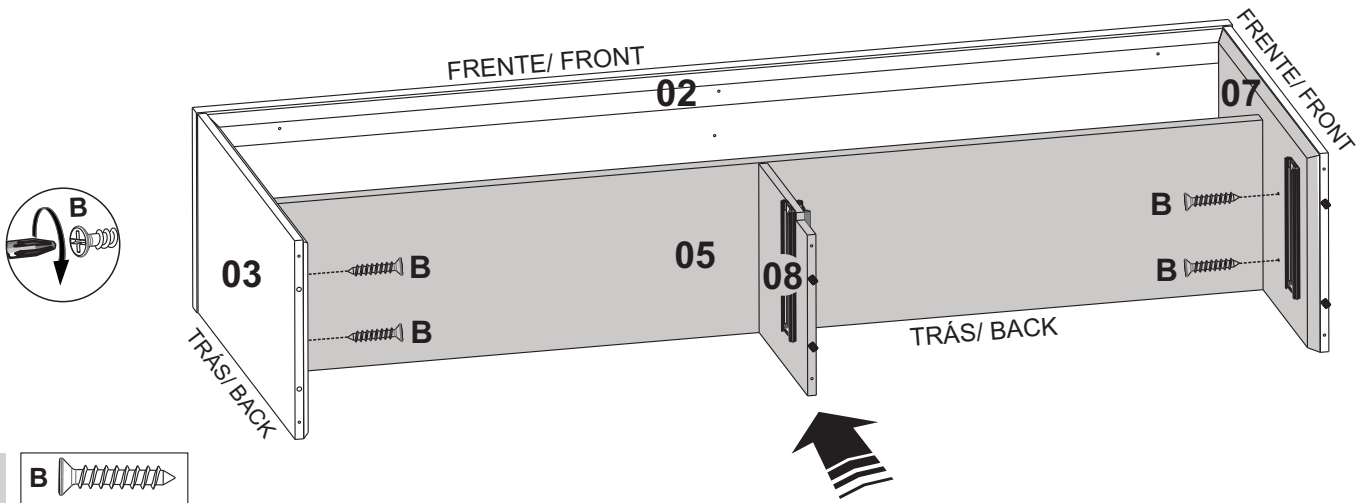

B=04

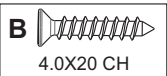

6

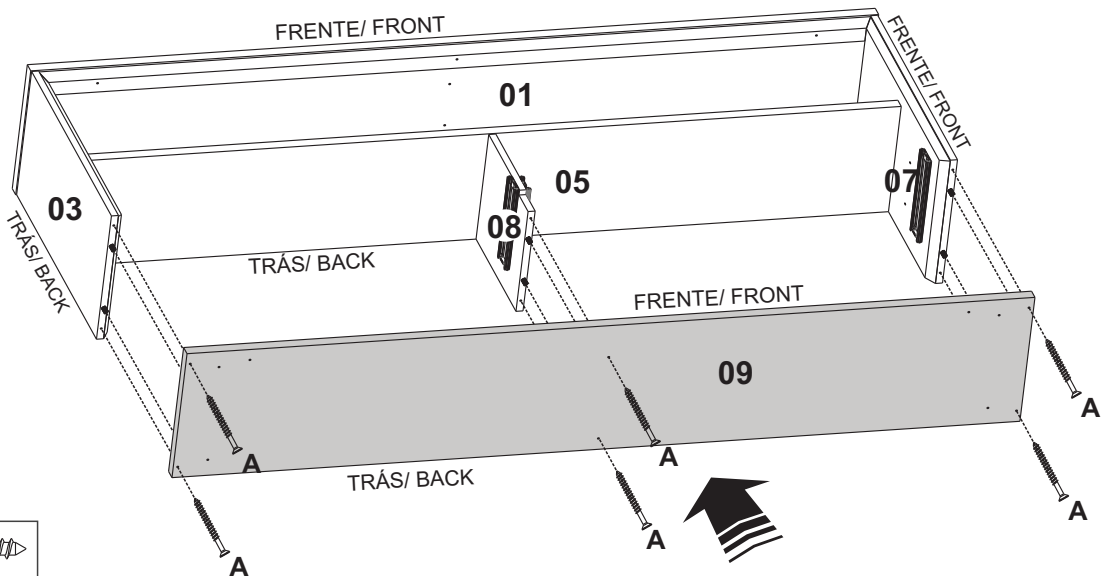

A=06

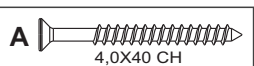

7

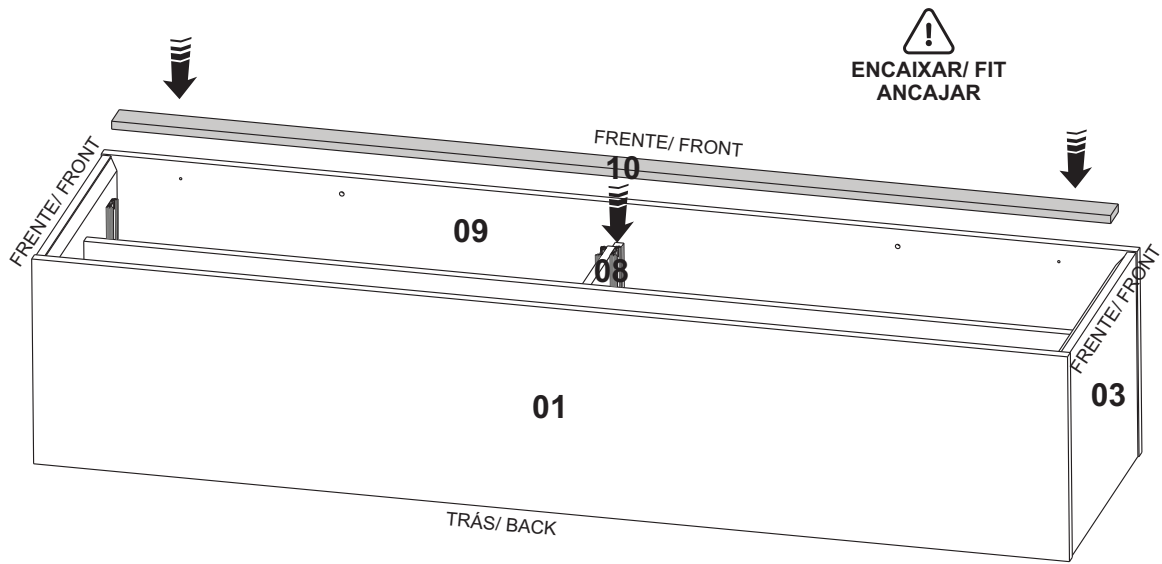

8

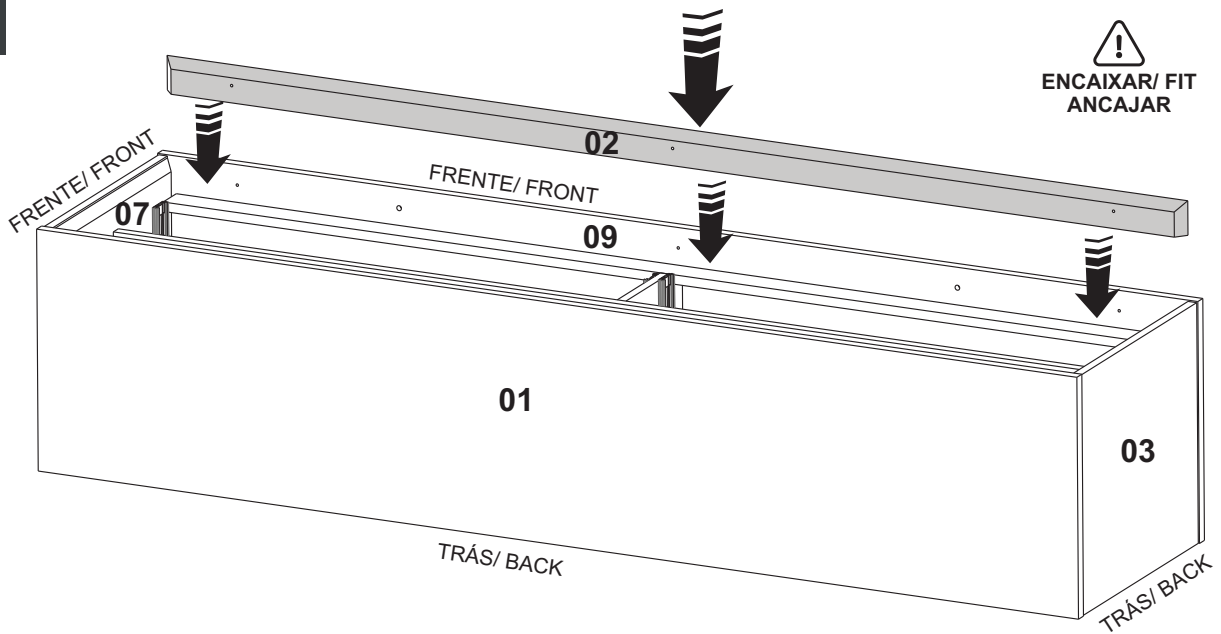

9

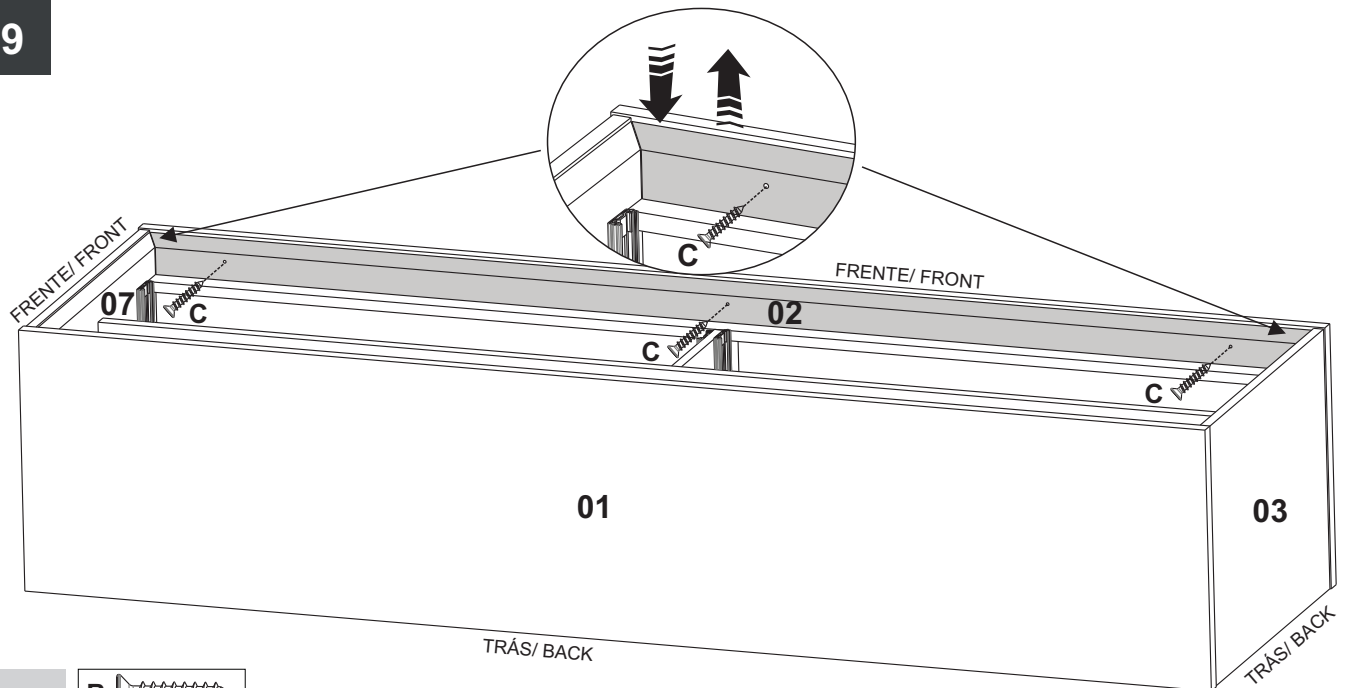

B=03

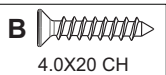

11

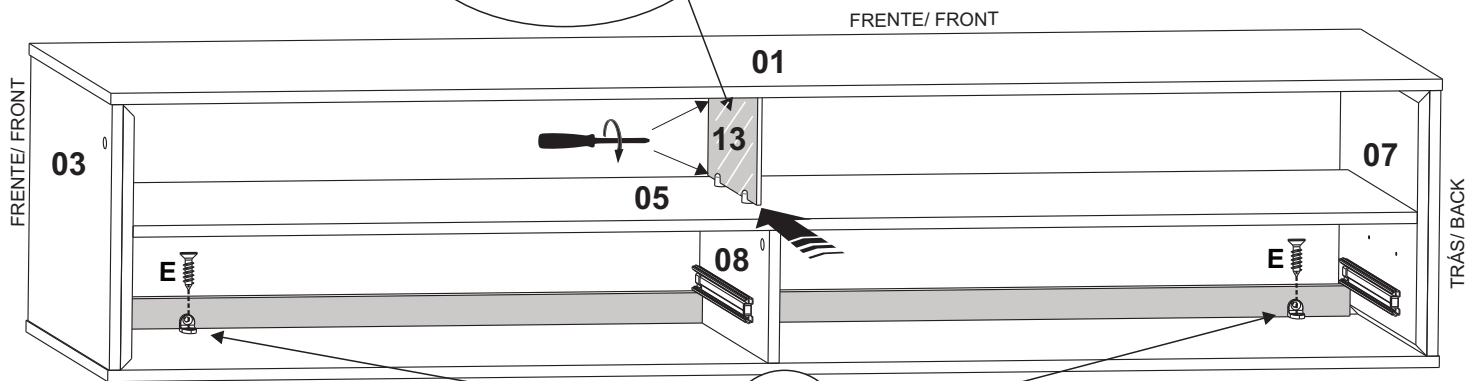
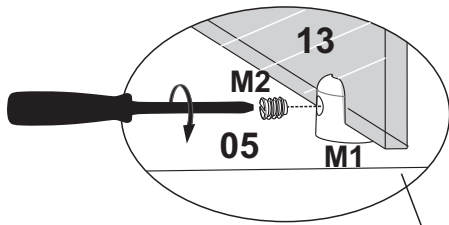

C=02
M2=04



10

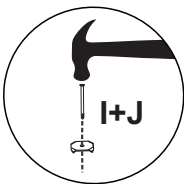

I=50
J=07

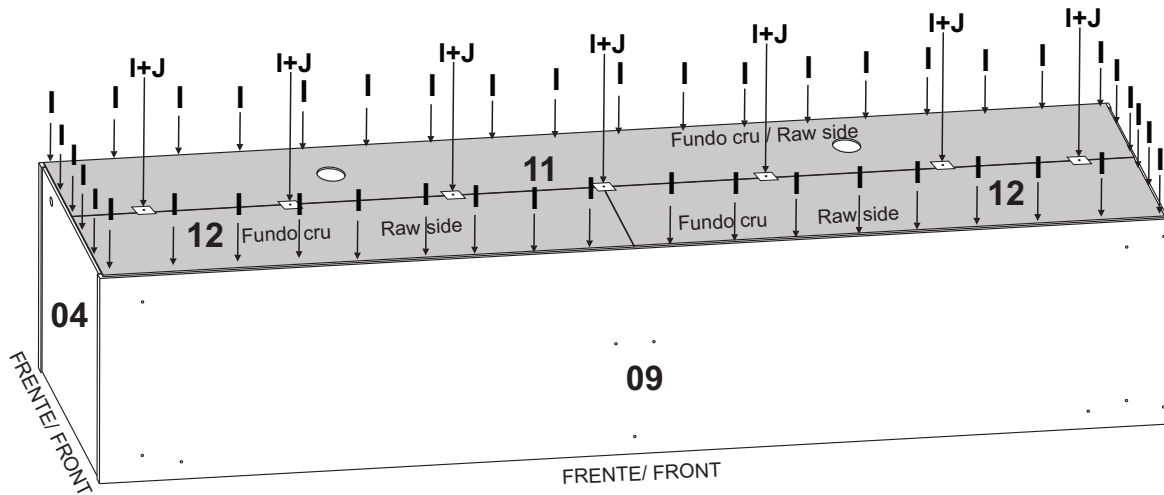
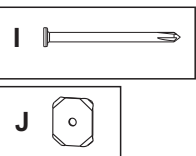

12

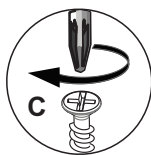

ATENÇÃO/
ATTENTION / ATENCION
T 4,0X30 CH

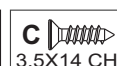
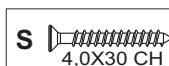
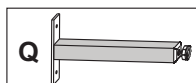
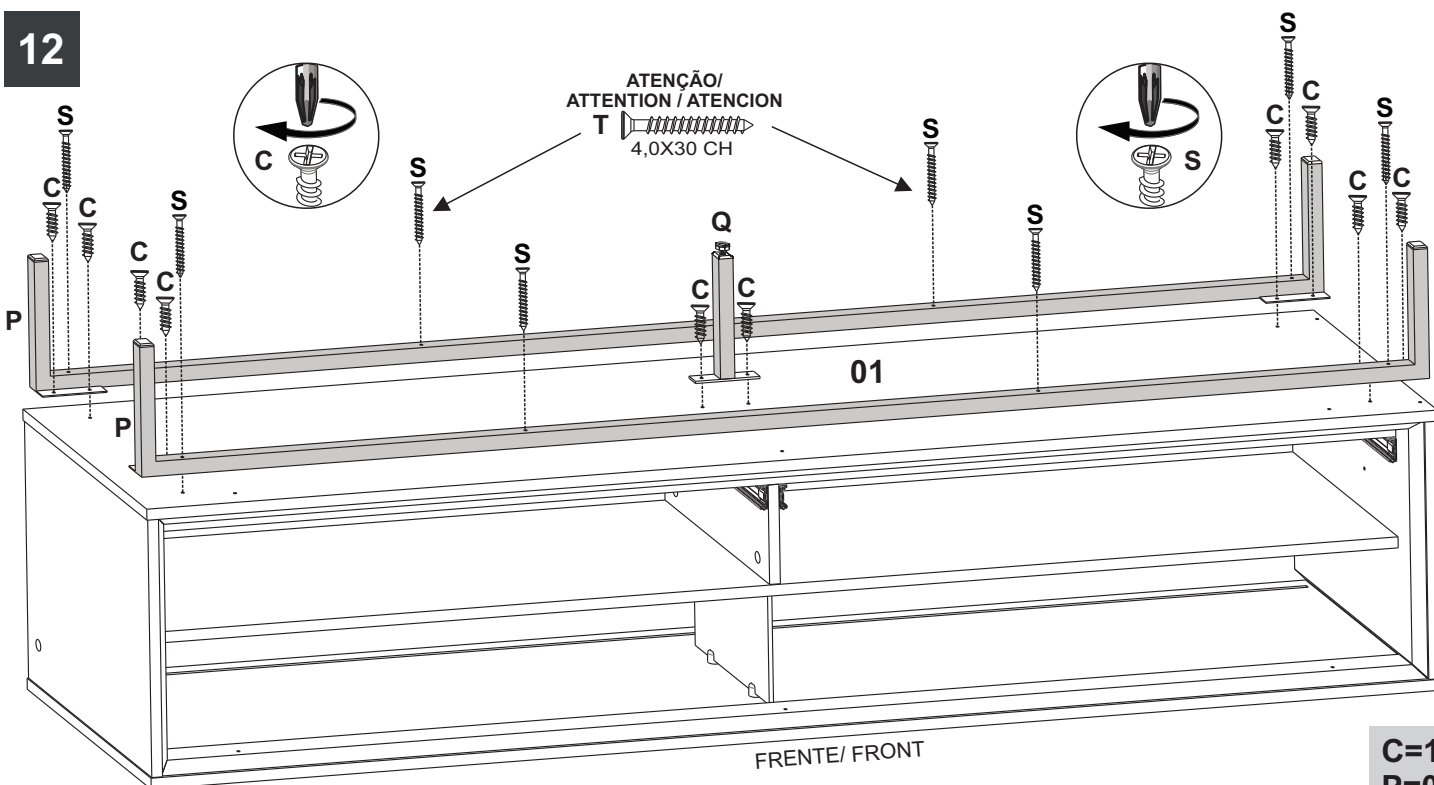
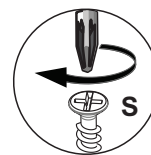

C=10
P=02
Q=01
S=08



**ATENÇÃO PARA A INSTALAÇÃO DO LED/
ATTENTION FOR LED INSTALLATION/ATENCIÓN PARA LA INSTALACIÓN LED**

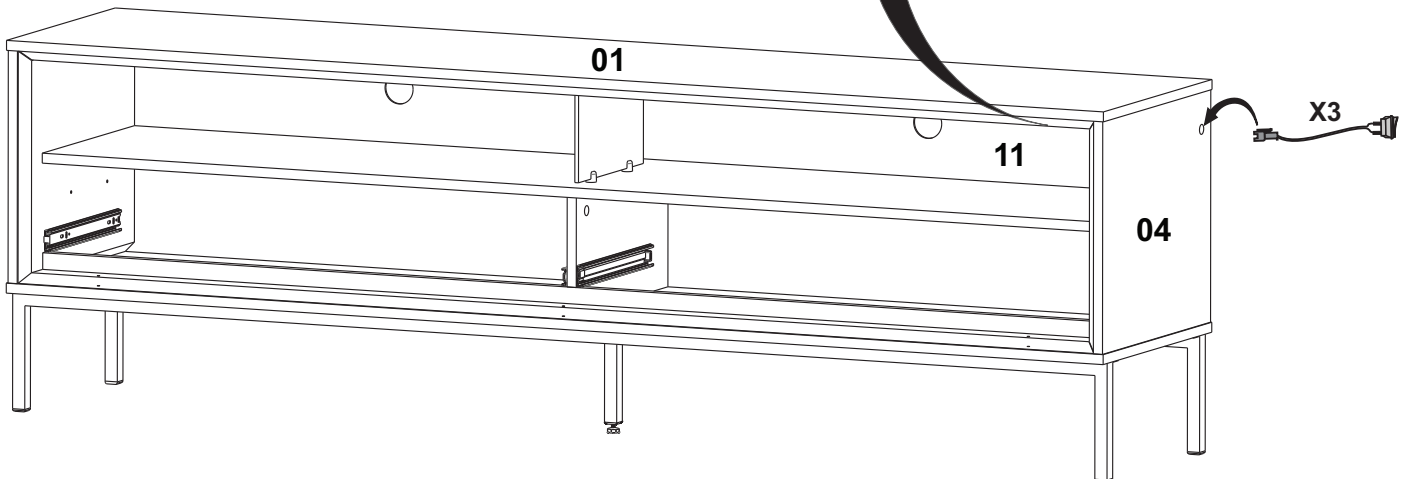
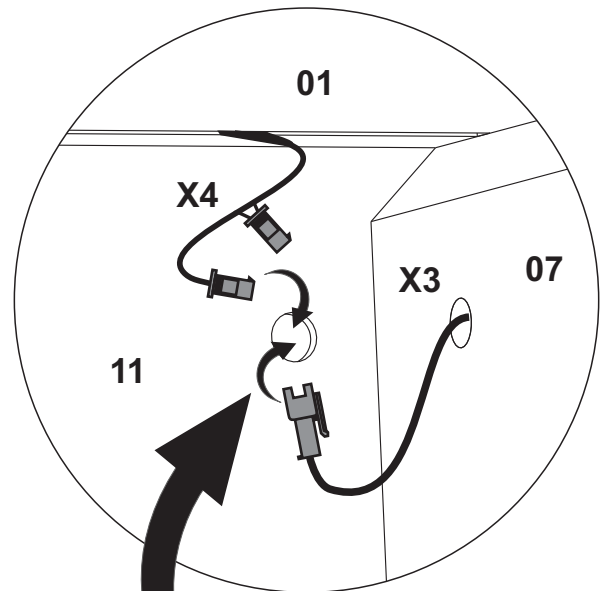
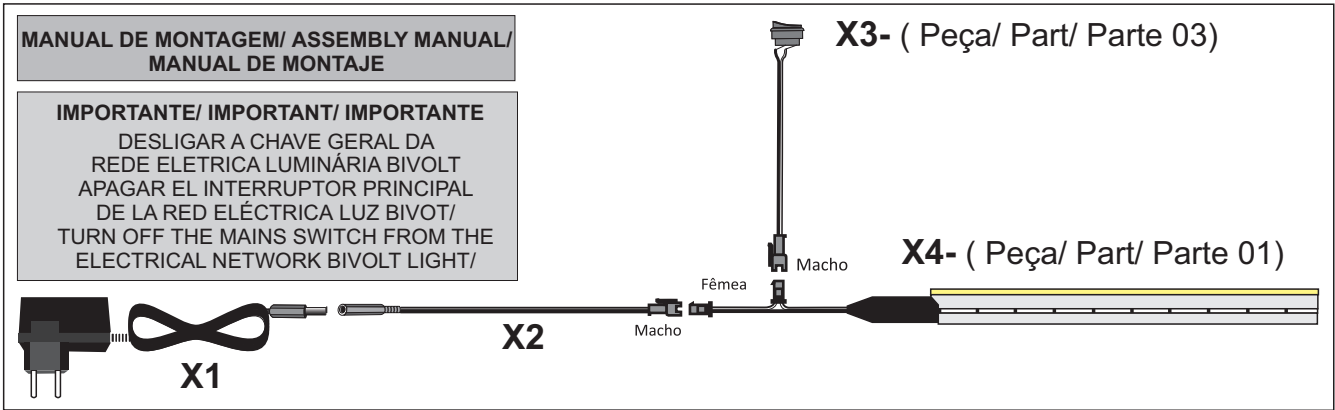

X3=01



14

X1=01
X2=01

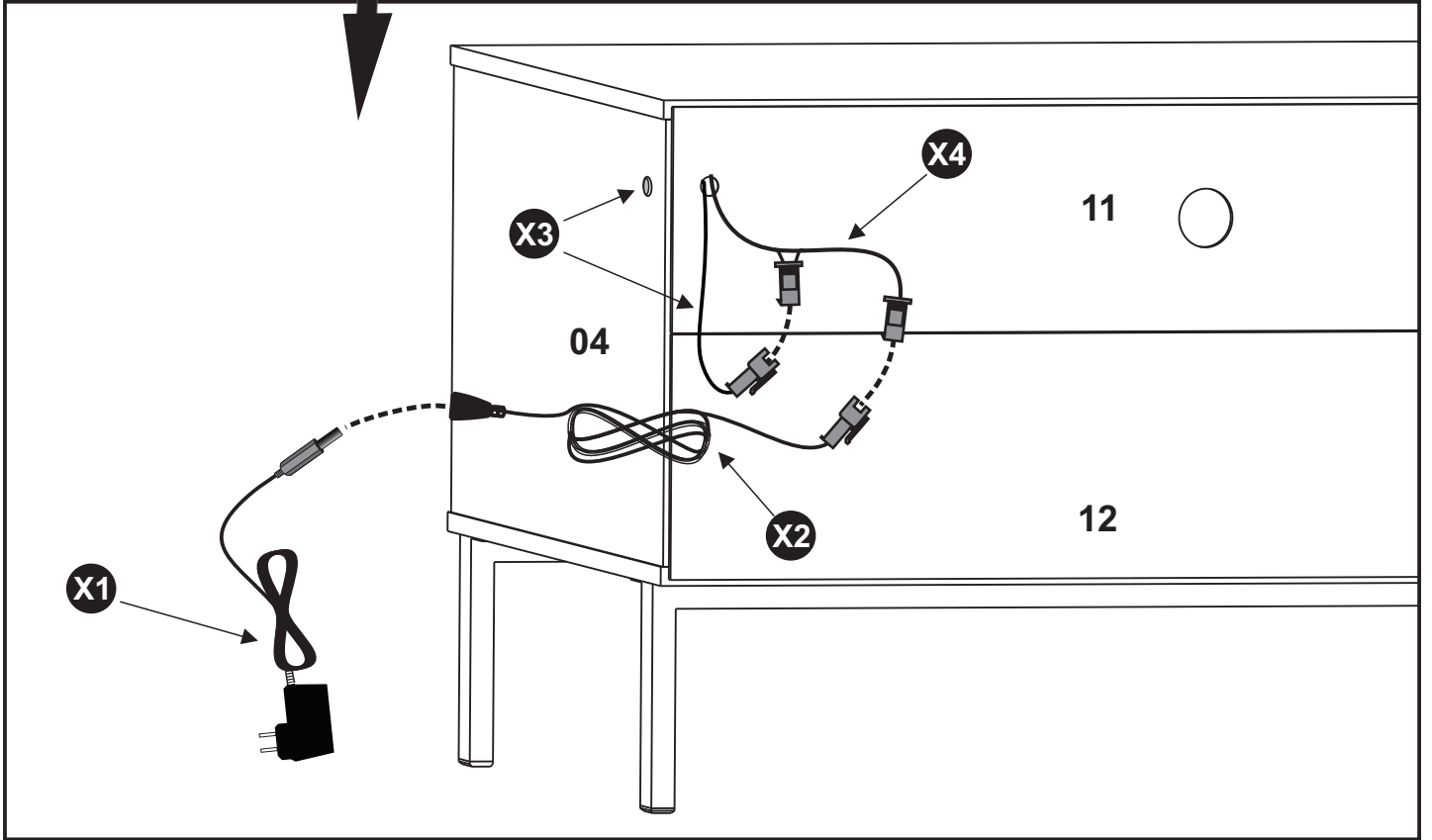
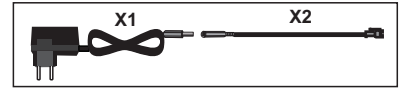
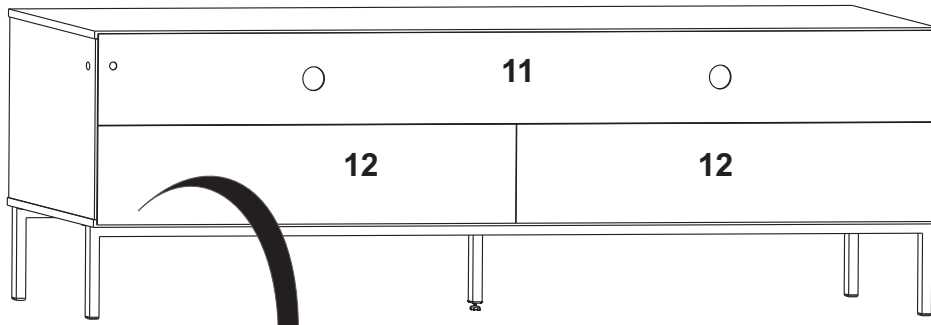

15

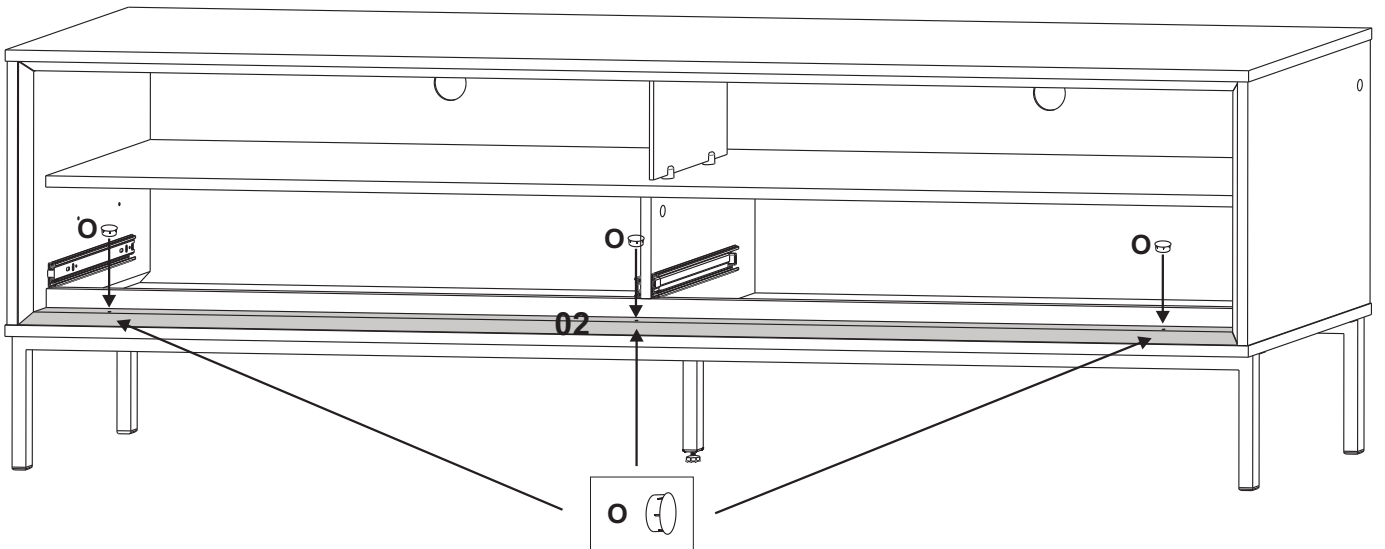

O=03

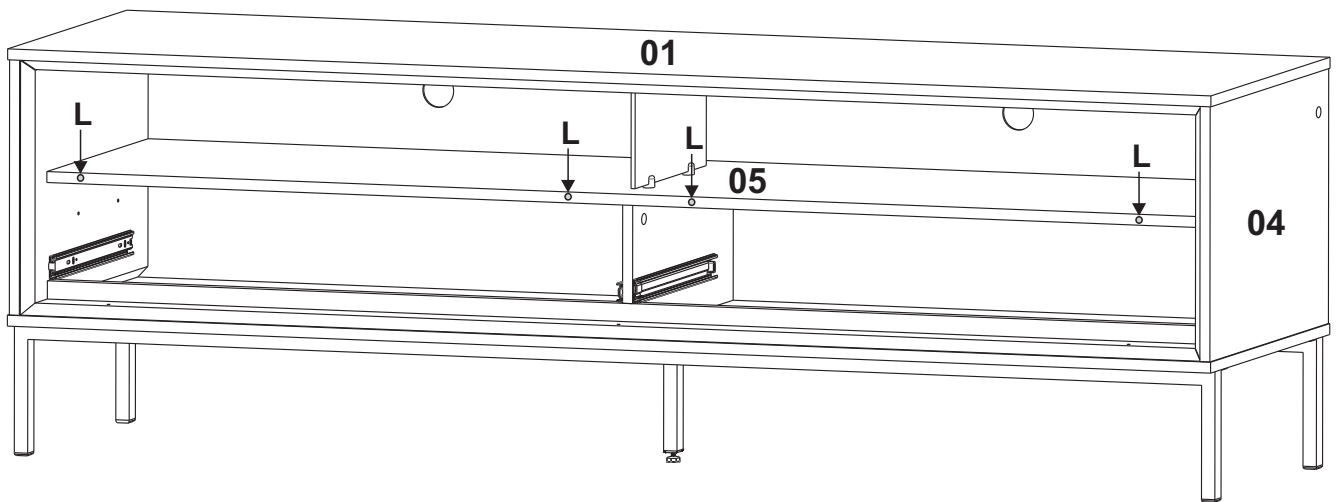

L=04



17

MONTAGEM DAS GAVETAS / ASSEMBLY OF THE DRAWER / MONTAJE LE CÁJON

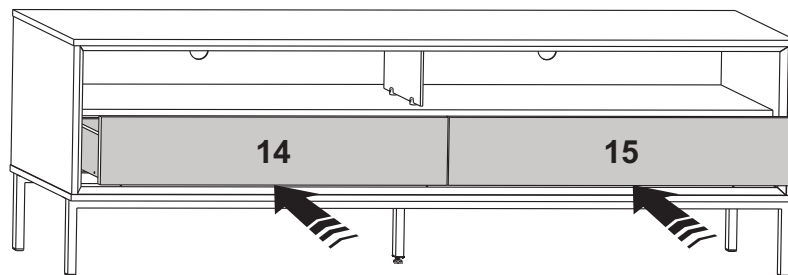
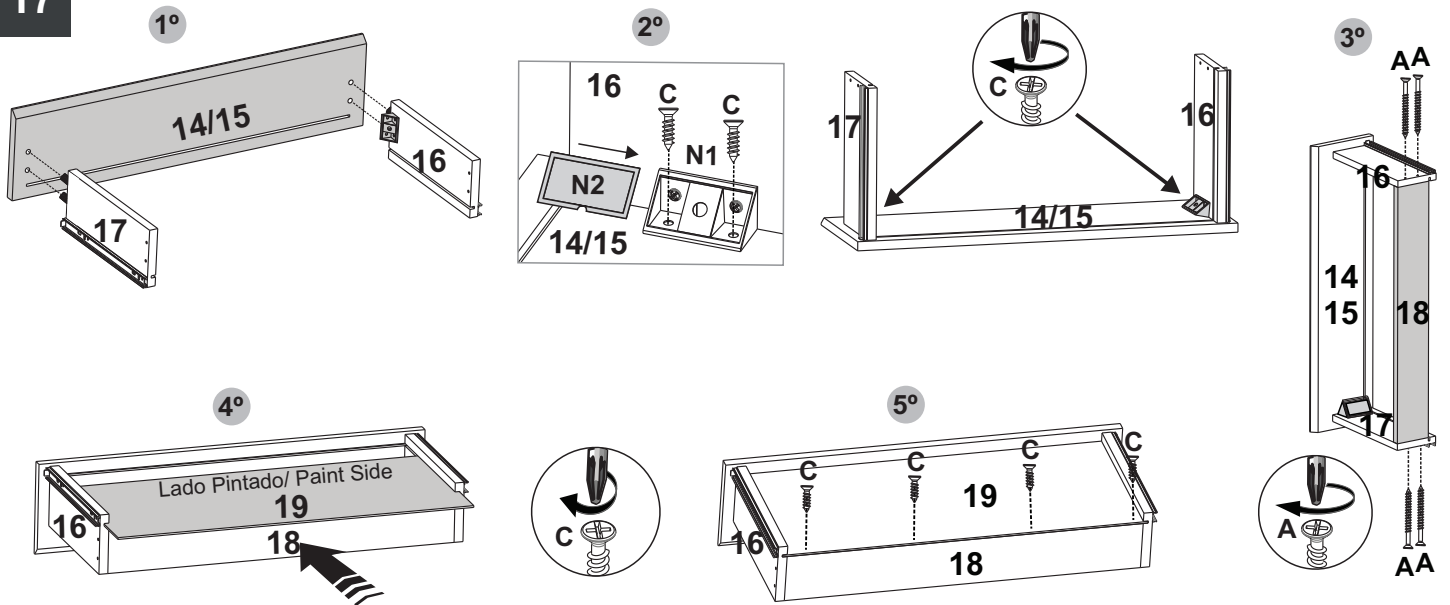

A=08
C=16
N2=04

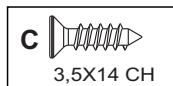
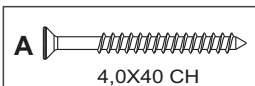

NOTA / NOTE

Não nos responsabilizamos por acidentes, se a instalação do móvel não estiver com os procedimentos deste Manual e não for realizado por pessoa habilitada. We are not responsible for accidents if the installation of the furniture is not in accordance with the procedures in this Manual and is not carried out by a qualified person. No nos hacemos responsables de accidentes si la instalación de los muebles no se realiza de acuerdo con los procedimientos de este Manual y no es realizada por una persona calificada.