

DIMENSÕES DO PRODUTO / PRODUCT DIMENSIONS / DIMENSIONS PRODUCT - WxDxH / LxDxA - 1750 X 388 X 440 MM

TV até 65"

PEÇAS NUMERADAS / NUMBERED PARTS / PIEZAS NUMERADAS

EX: 1915X-X 05(peça/ piece/ pieza number)

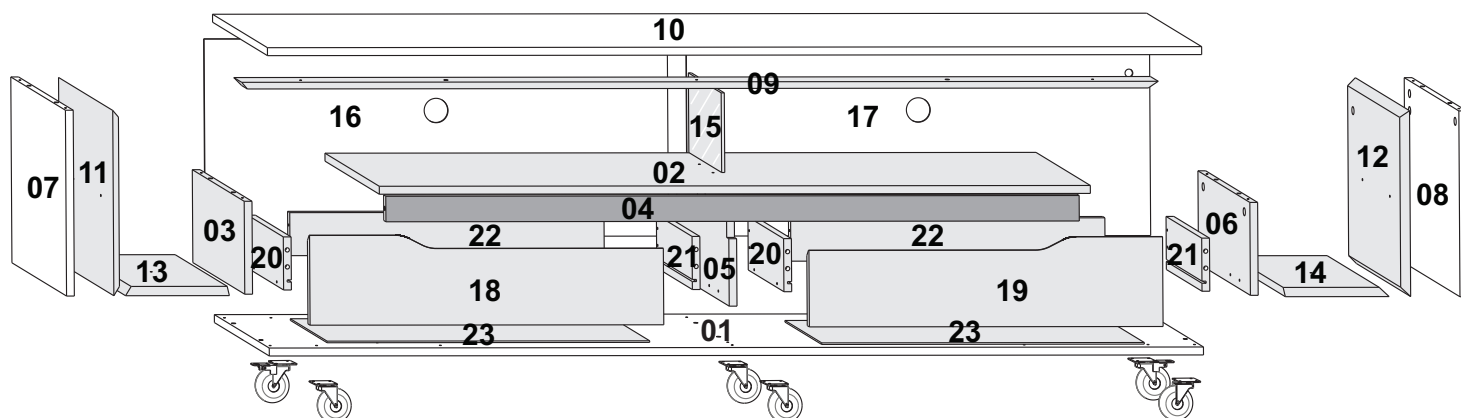
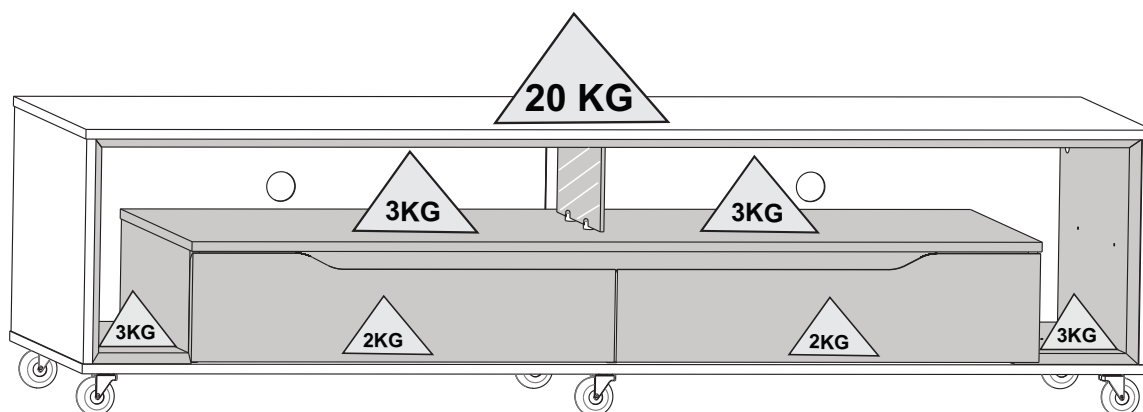

ATENÇÃO / ATTENTION / ATENCION

Nunca utilizar óleos, lustra móveis, produtos abrasivos, saponáceos, esponja de aço e outros.

Never use oils, furniture polish, abrasive products, soaps, steel sponge and others.

Nunca use aceites, pulimentos, abrasivos, jabones, esponja de acero y otros.

CUIDADOS ESPECIAIS/ SPECIAL CARE/ CUIDADOS ESPECIALES

- Evitar expor o móvel ao sol, e em lugares úmidos.
- Limpar com flanela seca ou com pano levemente umedecido em água.

- Avoid exposing the furniture to the sun, and in damp places.
- Clean with dry flannel or lightly cloth moistened with water.

- Evite exponer los muebles al sol y en lugares húmedos.
- Limpiar con flanela seca o un paño ligero, humedecido con agua.

Ferramentas necessárias / Necessary tools / Herramientas Necesarias
(não fornecidas) (not provided) (No proporcionadas)



1

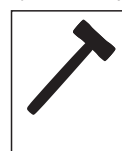

MONTAR O PRODUTO SOBRE A EMBALAGEM, EVITANDO DANOS NA PINTURA. ACONSELHAMOS QUE A MONTAGEM DO PRODUTO SEJA POR UM PROFISSIONAL.

SETUP THE PRODUCT ON TOP OF THE PACKAGING, AVOIDING DAMAGE TO THE PAINT. WE RECOMMEND THAT THE INSTALLATION IS DONE BY A PROFESSIONAL.

MONTAR EL PRODUCTO EN EL PAQUETE, EVITAR LESIONES EN PINTURA. AVISAMOS QUE EL MONTAJE DEL PRODUCTO SEA UN PROFESIONAL.



MEDIDA UTILIZADA EM MM / UNIT MEASURE USED IS MILLIMETERS (MM)

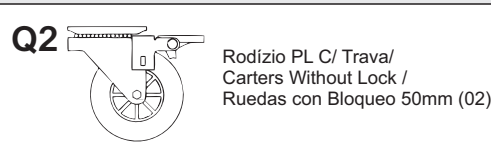
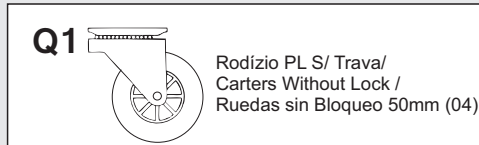
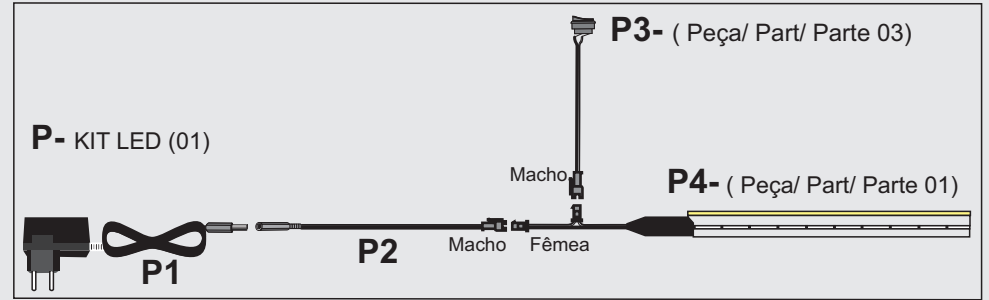
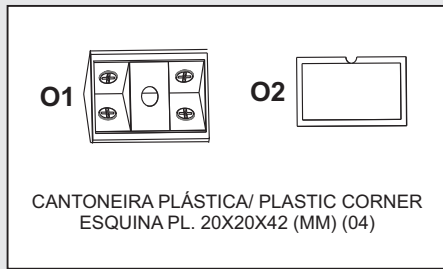
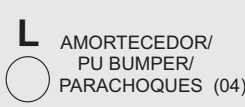
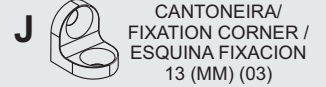
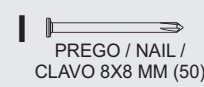
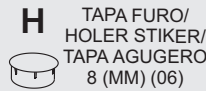
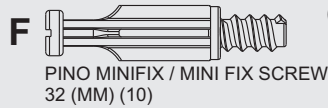
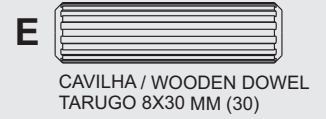

ITEM		DESCRIÇÃO DA PEÇAS / DESCRIPTION OF PARTS / UNIT MEASURE USED IS MILLIMETERS (MM)	CORES/COLOR/COLORES					
CÓDIGO CODE	Nº	NOME/NAME/NOMBRE	MEDIDAS / MEASURES (MM)	TIPO TYPE	QUANT AMOUNT CANTIDAD	CEDRO AC	OFF WHITE/ BEGE AC	PRETO AC
19765	1	BASE	1750X385X15	MDP	01	02/03		
19766	2	TAMPO NICHOS	1350X381X15	MDP	01		03/06	03/07
19767	3	LATERAL ESQ. NICHOS/ LEFT SIDE/ LADO IZQUIERDO	364X175X15	MDP	01		04/06	04/07
19768	4	VISTA FRONTAL/ FRONT VIEW	1316X48X15	MDP	01	05/03		
19769	5	DIVISOR NICHOS/DIVIDER	364X175X15	MDP	01		06/06	06/07
19770	6	LATERAL DIR. NICHOS/ RIGHT SIDE/ LADO DERECHO	364X175X15	MDP	01		07/06	07/07
19771	7	LATERAL ESQUERDA/ LEFT SIDE/ LADO IZQUIERDO	383X350X15	MDP	01	08/03		
19772	8	LATERAL DIREITA/ RIGHT SIDE/ LADO DERECHO	383X350X15	MDP	01	09/03		
19773	9	TAMPO INTERNO/ INTERNAL TOP/ TAMPO INTERNO	1716X55X15	MDF	01		10/06	10/07
19774	10	TAMPO SUPERIOR/ TOP HIGHT	1750X385X15	MDP	01	11/03		
19775	11	LATERAL INTERNA ESQ/ LEFT INTERNAL SIDE/ LADO INTERNO IZQUIERDO	380X349X15	MDF	01		12/06	12/07
19776	12	LATERAL INTERNA DIR/ RIGHT INTERNAL SIDE/ LADO INTERNO DERECHO	380X349X15	MDF	01		13/06	13/07
19777	13	BASE INTERNA ESQ./ LEFT BASE	380X185X15	MDF	01		14/06	14/07
19778	14	BASE INTERNA DIR./	380X185X15	MDF	01		15/06	15/07
19227	15	VIDRO/ GLASS/ CRISTAL	230X150X6		01			
19779	16	FUNDO TRAS / BACK / TRASEIRO	869X372X3	TRI	01	17/03		
19780	17	FUNDO TRAS / BACK / TRASEIRO	869X372X3	TRI	01	18/03		
19781	18	FRENTE GAV. ESQ./LEFT DRAWER FRONT/ FRENTE DE CÁJON IZQUIERDA	669X167X15	MDF	01		19/06	19/07
19782	19	FRENTE GAV. DIR./RIGHT/ DRAWER FRONT/ FRENTE DE CÁJON DERECHA	669X167X15	MDF	01		20/06	20/07
19783	20	LATERAL GAV. ESQ./ LEFT DRAWER SIDE/ LADO CAJON IZQUIERDO	250X100X15	MDP	02		21/06	21/07
19784	21	LATERAL GAV. DIR./ RIGHT DRAWER SIDE/ LADO CAJON DERECHA	250X100X15	MDP	02		22/06	22/07
19785	22	CONTRA FRENTE GAVETA/ AGAINST DRAWER FRONT/ CONTRA EL FRENTE DE CÁJON	595X81X15	MDP	02		23/06	23/07
19786	23	FUNDO GAVETA/ DRAWER BACKGROUND/ FONDO CÁJON	611X258X3	TRI	02		24/06	24/07
438	A	PF. / Screw / Tornillo 4,0x40(MM) CH			18			
433	B	PF. / Screw / Tornillo 4,0x20(MM) CH			09			
986	C	PF. / Screw / Tornillo 3,5x14(MM) CRR			57			
2921	D	Cavilha / Wooden Dowel / Tarugo 8x20(MM)			02			
137	E	Cavilha / Wooden Dowel / Tarugo 8x30(MM)			30			
532	F	Pino Minifix / Minifix Screw 32(MM)			10			
508	G	Tambor Minifix / Minifix Round Nut 15(MM)			10			
254						CAFÉ		
7687	H	Tapa Furo / Hole Sticher/ Tapa Agujero 8 (MM)			06		BRANCO	
952								PRETO
248	I	Prego / Nail / Clavo 8x8(MM)			50			
11136	J	Cantoneira Zamac/Corner/ Esquina 13x13 MM			03			
18147	K	Corrediça/Metallic Slid/ Corredeira Metal 250(MM) (02 Pair)			02 Par			
3441	L	Amortecedor/ Pu Bumper/ Parachoques 8 MM			04			
340	M1/M2	Suporte de Vidro/ Glass Suport/ Soporte de Vidrio- 16X16 (MM)			04			
911	N	Garra/ Jont Metal Plate/ Embragues			03			
15175	O1/O2	Cantoneira Plástica/ Plast. Coner Whit Lid/ Esquina PL. 20X20X42 (MM)			04	CINZA	CINZA	CINZA
19242	P	Kit Led- NEON- 1750 MM			01			
8226	Q1	RODIZIO SILICONE SEM TRAVA 60MM			04			
8737	Q2	RODIZIO SILICONE COM TRAVA 60MM			02			
		Certif. de Garant./ Warranty Certif.			01			

PREPARAÇÃO DE PEÇAS/ PARTS PREPARATION / PREPARACION DE PIEZAS

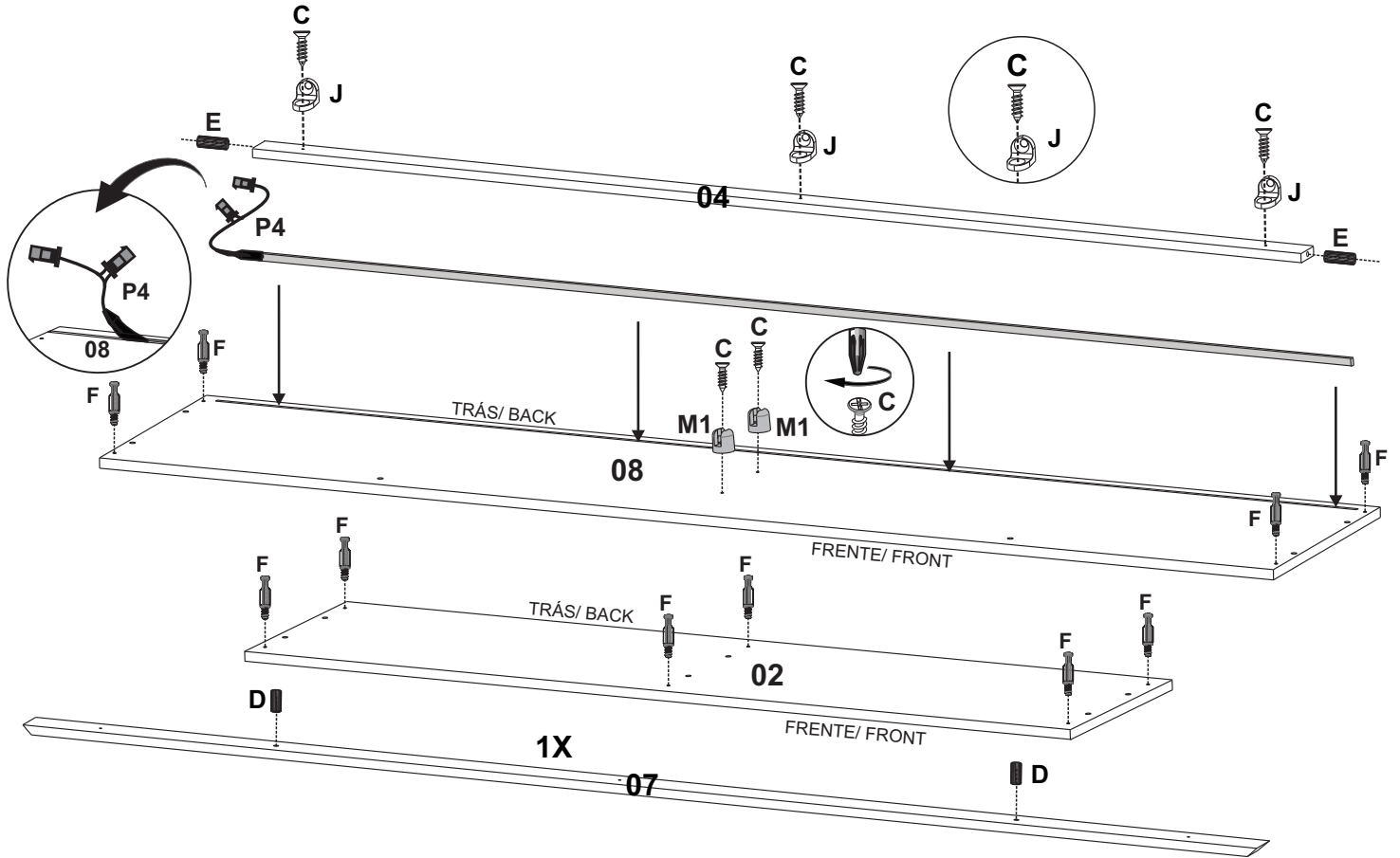
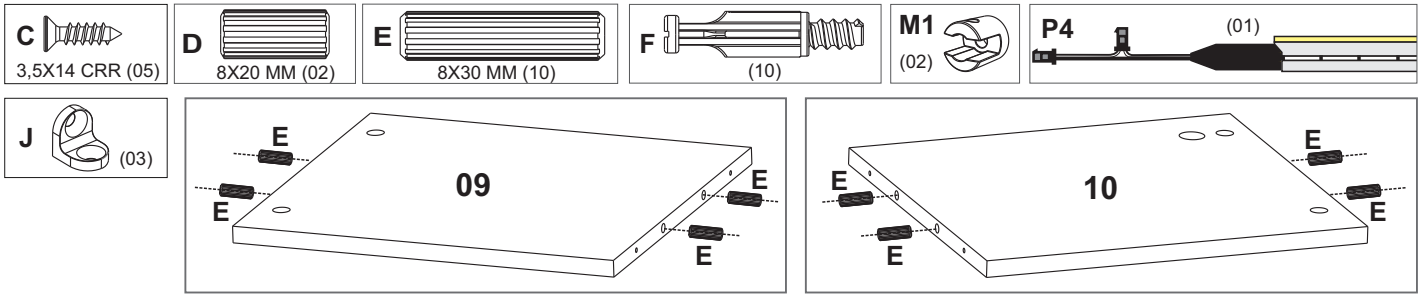

1

G=02

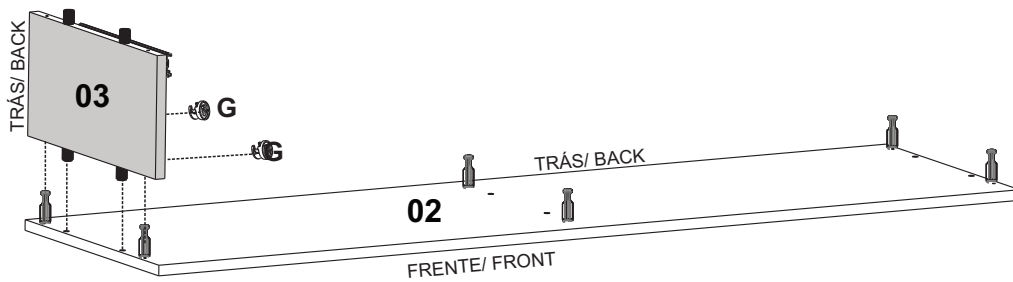

2

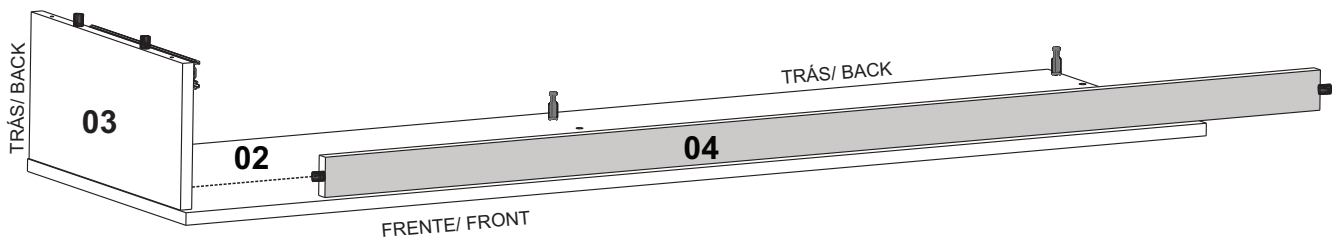

5

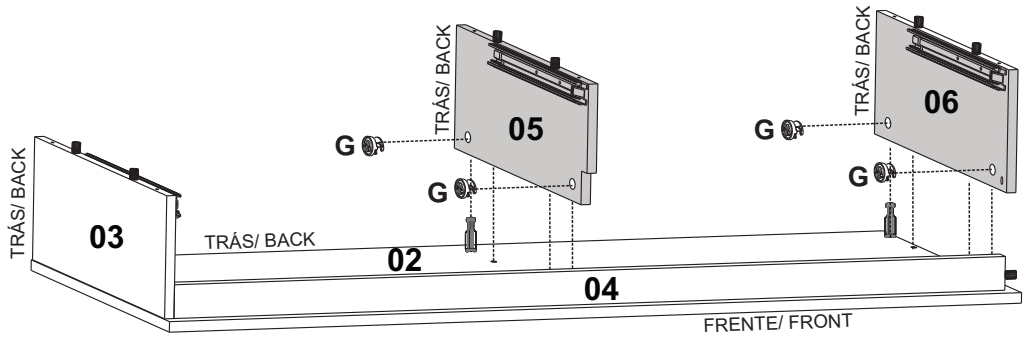

G=04 

6

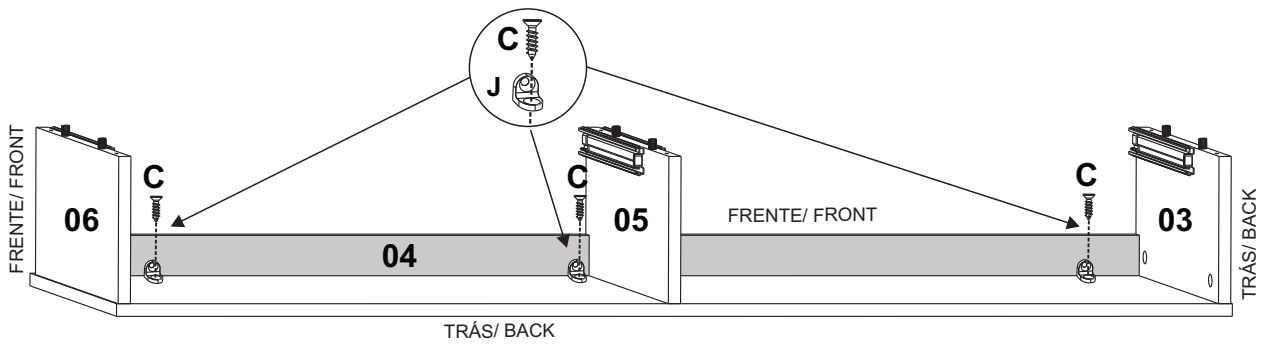

C=03

C 

7

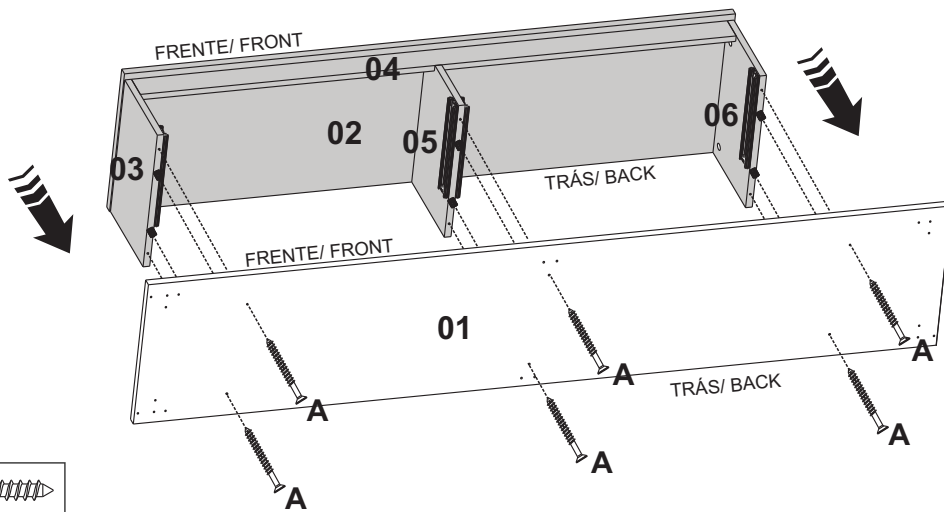

A=06

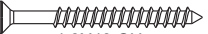
A  4,0X40 CH

8

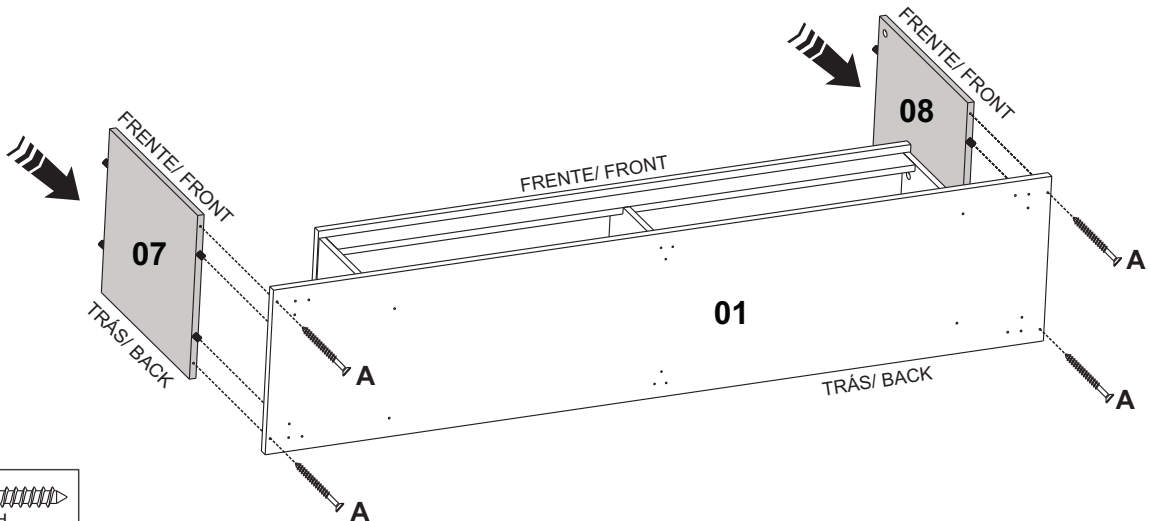

A=04

A  4,0X40 CH

9

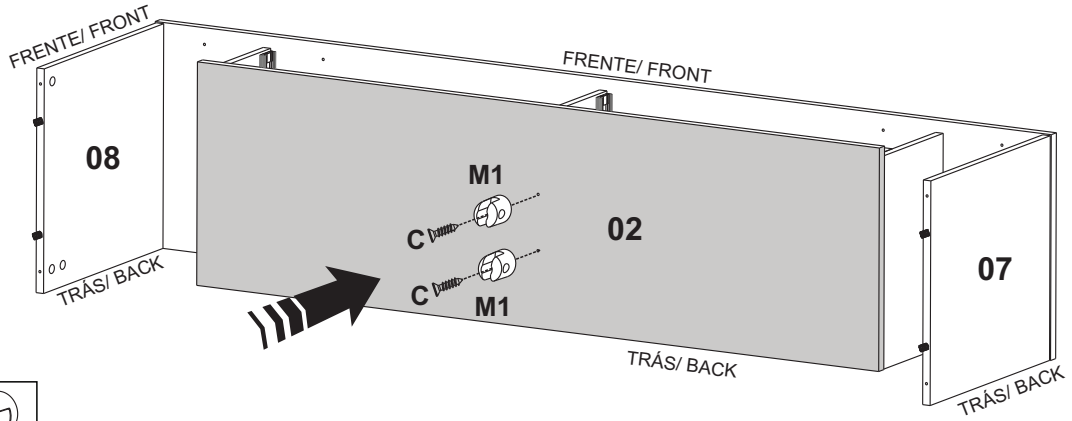

C=02
M1=02

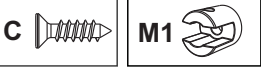

10

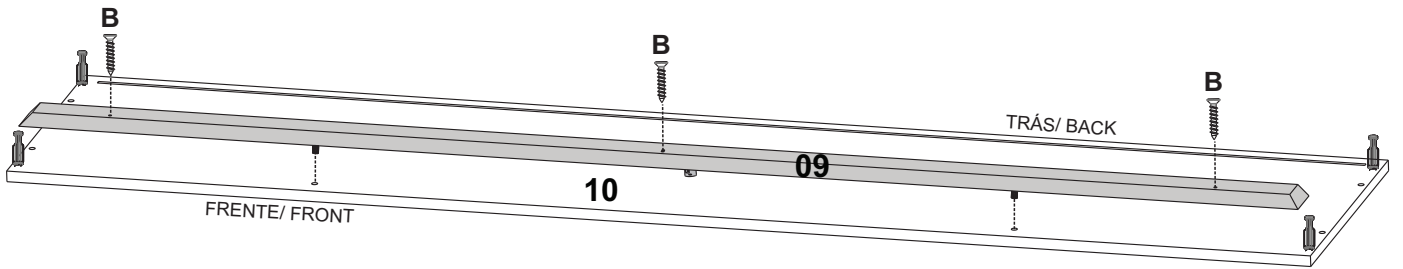

B=03

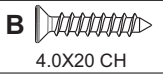

11

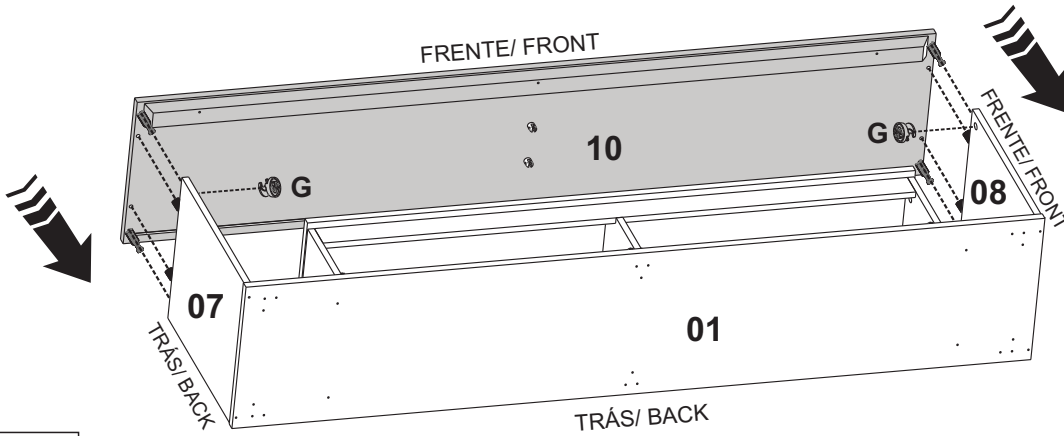

G=04



12

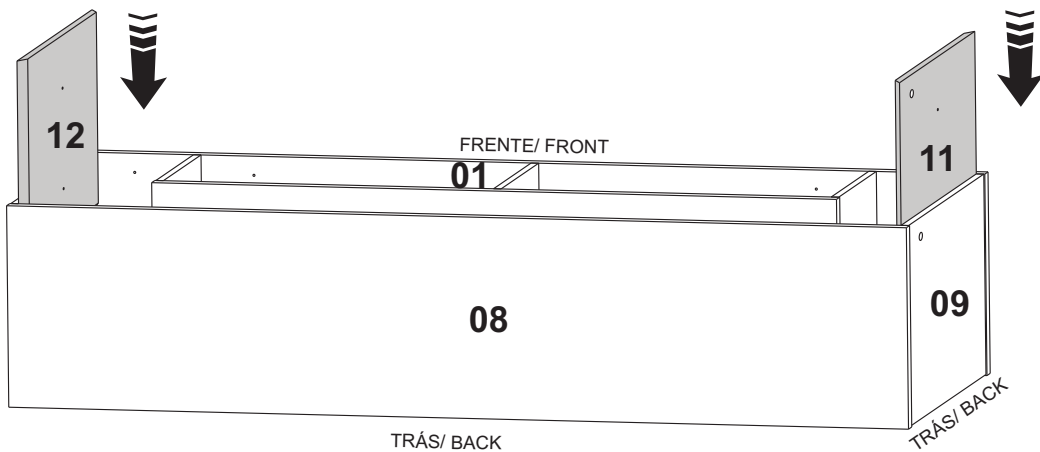

13

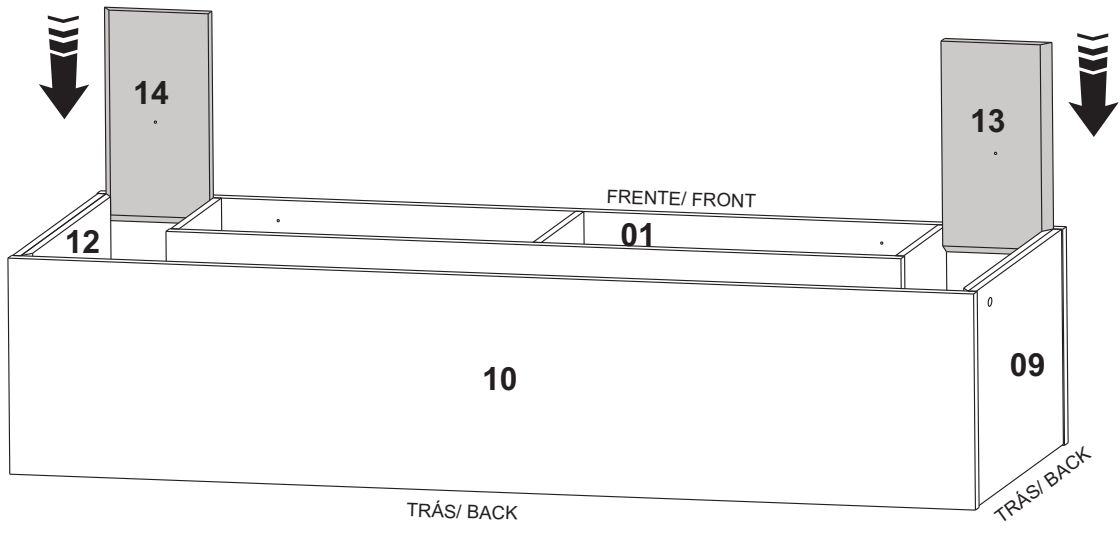

14

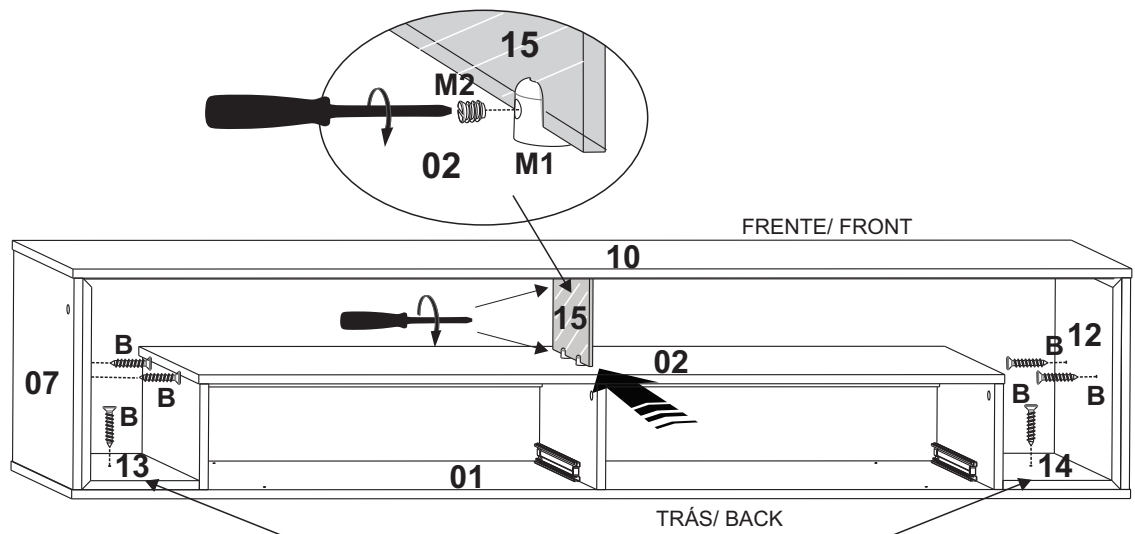

B=06
M2=04

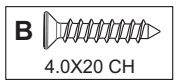
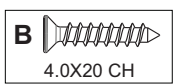

15

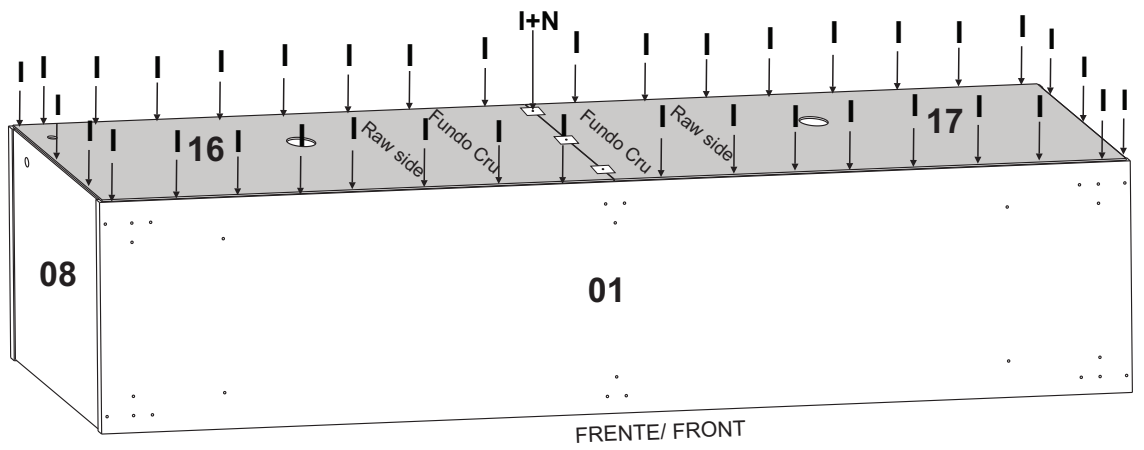
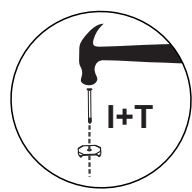

I=50
N=03

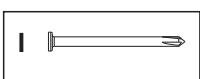

16

C=24
Q1=04
Q2=02

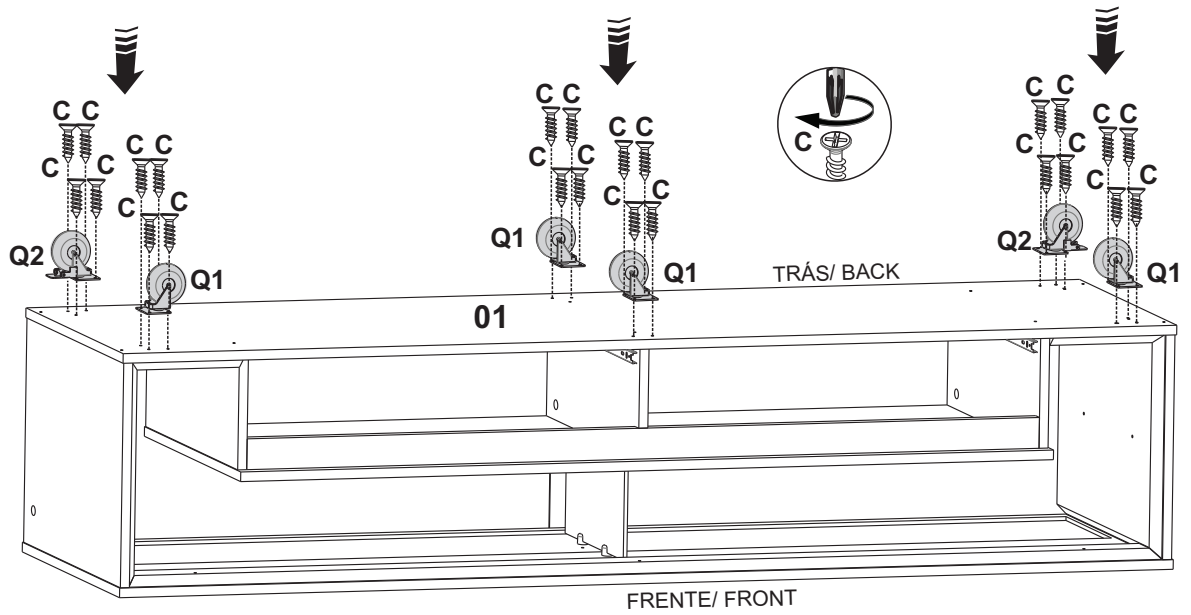
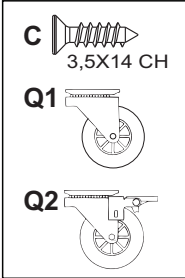

18

MANUAL DE MONTAGEM/ ASSEMBLY MANUAL/ MANUAL DE MONTAJE

IMPORTANTE/ IMPORTANT/ IMPORTANTE
 DESLIGAR A CHAVE GERAL DA REDE ELETRICA LUMINÁRIA BIVOLT
 APAGAR EL INTERRUPTOR PRINCIPAL DE LA RED ELÉCTRICA LUZ BIVOLT/
 TURN OFF THE MAINS SWITCH FROM THE ELECTRICAL NETWORK BIVOLT LIGHT/

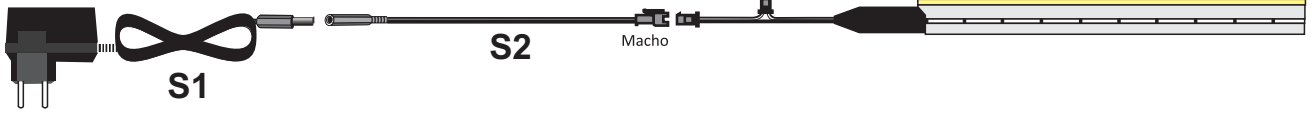

Siga o manual



**ATENÇÃO PARA A INSTALAÇÃO DO LED/
 ATTENTION FOR LED INSTALLATION/
 ATENCIÓN PARA LA INSTALACIÓN LED**

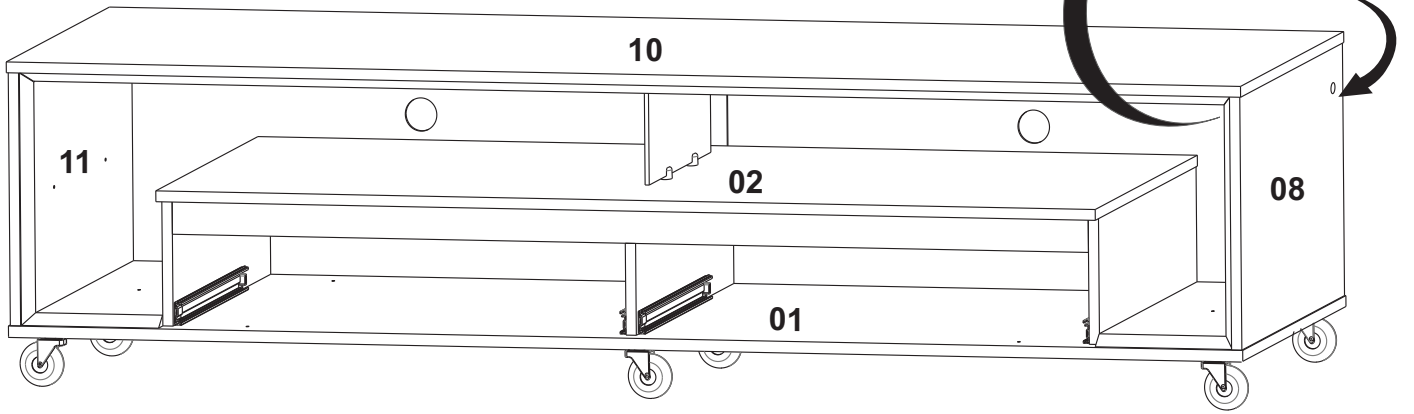
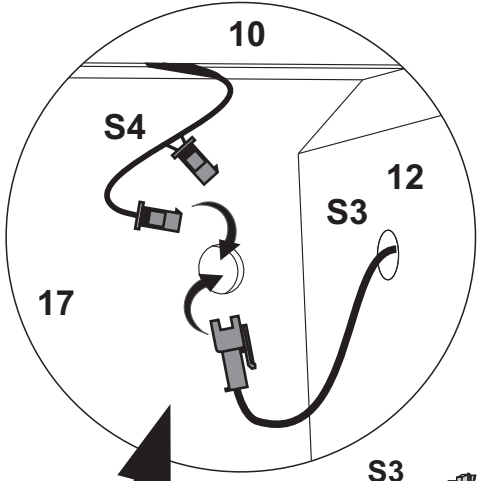

17

S1=01
S2=01

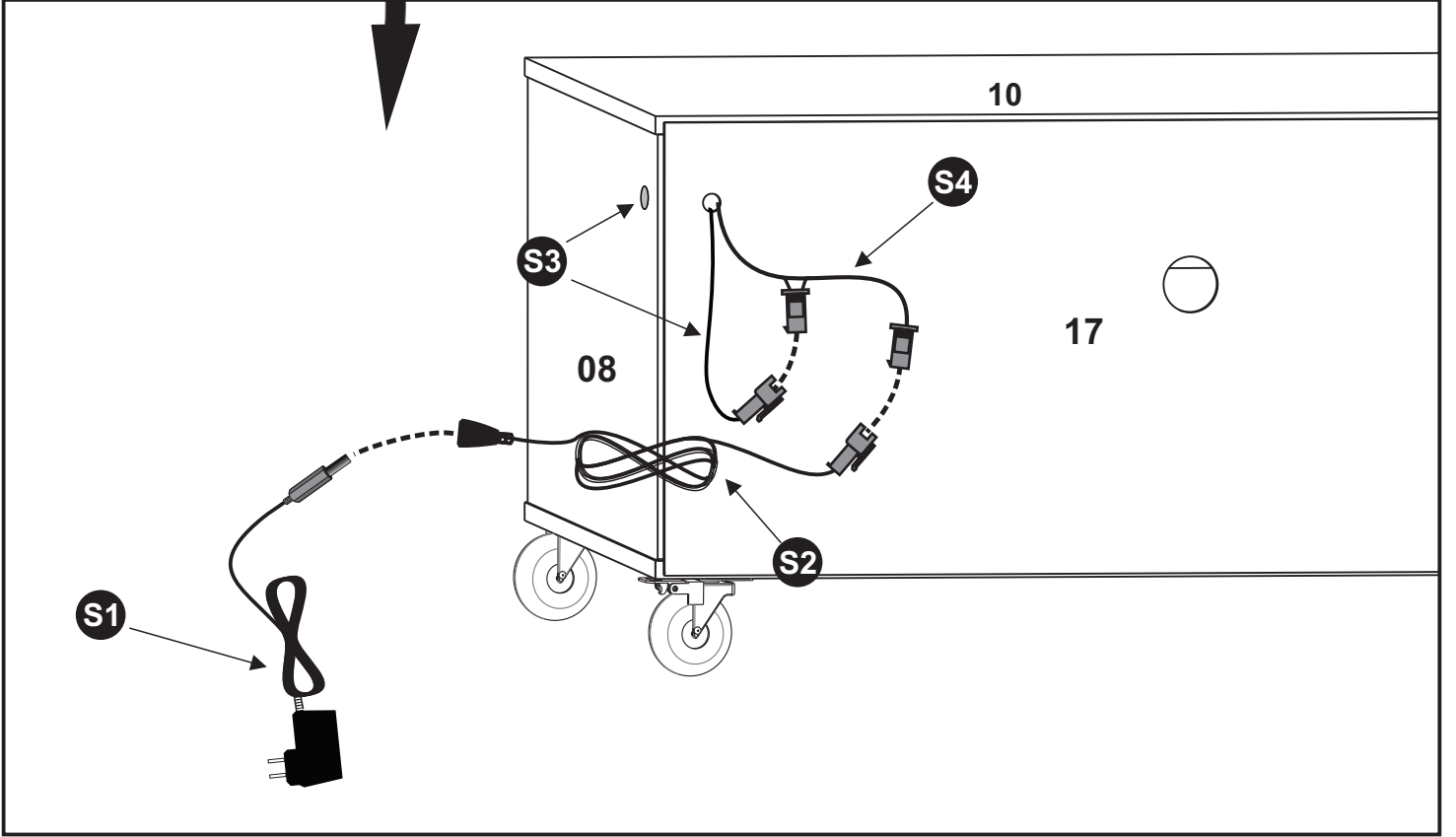
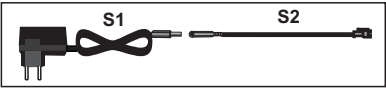
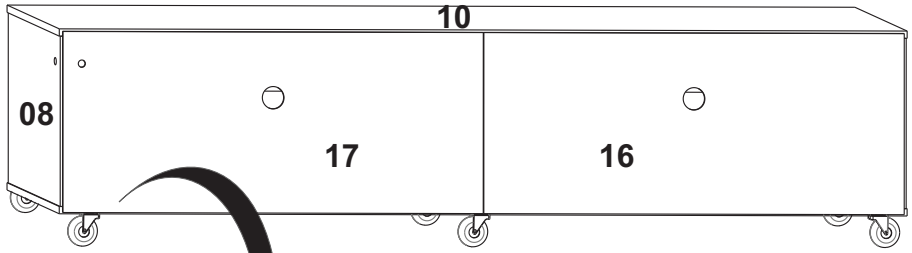

18

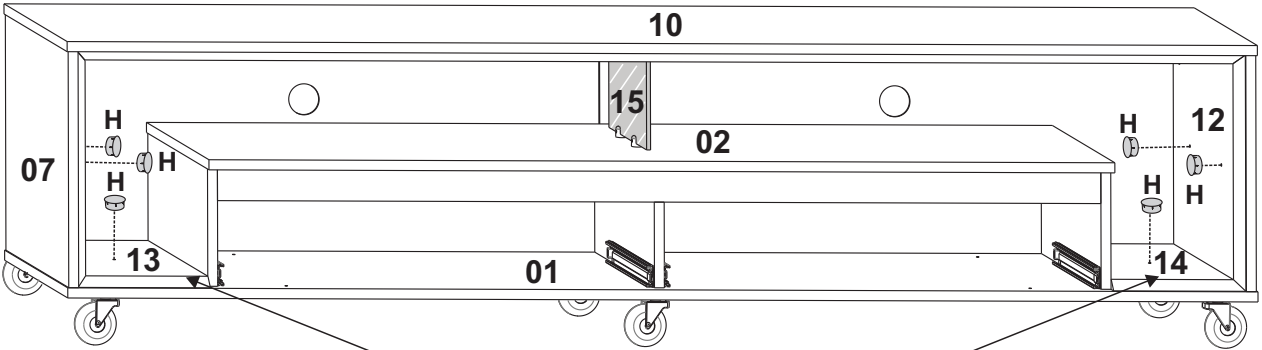

H=06 H (Phillips head screw icon)

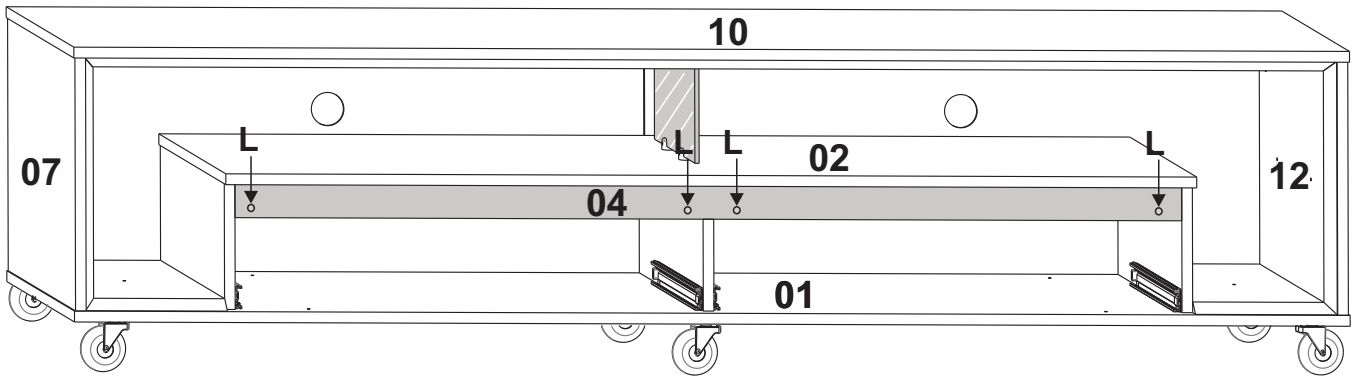

L=04



20

MONTAGEM DAS GAVETAS / ASSEMBLY OF THE DRAWER / MONTAJE LE CÁJON

1º

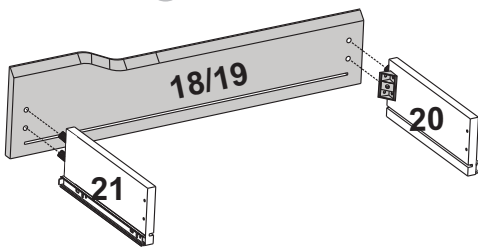

2º

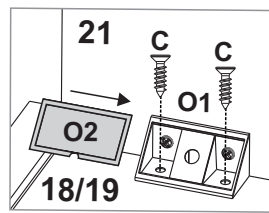

3º

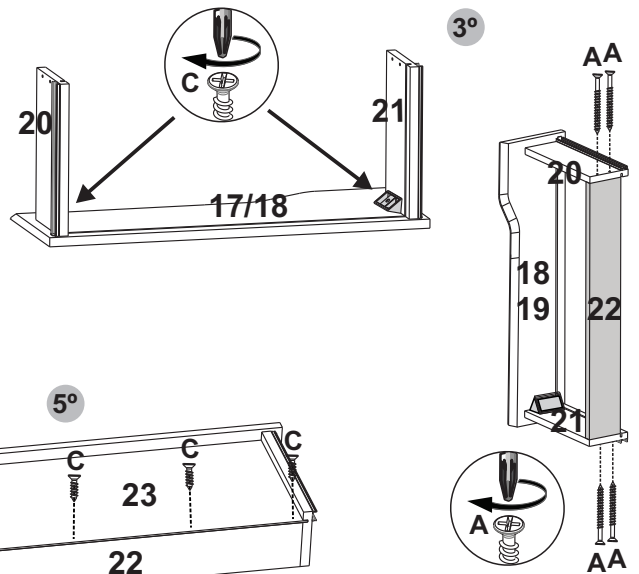

4º



5º

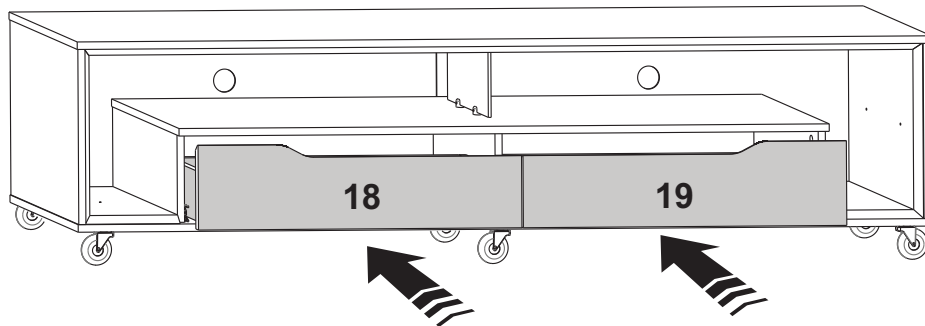
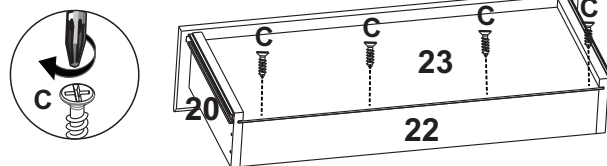

A=08
C=16
Q2=04

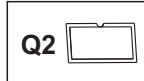
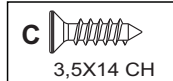
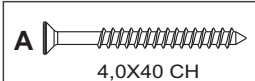

NOTA / NOTE

Não nos responsabilizamos por acidentes, se a instalação do móvel não estiver com os procedimentos deste Manual e não for realizado por pessoa habilitada. We are not responsible for accidents if the installation of the furniture is not in accordance with the procedures in this Manual and is not carried out by a qualified person. No nos hacemos responsables de accidentes si la instalación de los muebles no se realiza de acuerdo con los procedimientos de este Manual y no es realizada por una persona calificada.