

**Altura: 605**  
**Largura: 1600**  
**Profundidade: 310**

## **ATENÇÃO**

- ➔ Ler atentamente toda a instrução antes de iniciar a montagem;
- ➔ A montagem do produto deverá ser feita em superfície limpa e plana;
- ➔ Aconselhamos utilizar a embalagem do produto para forrar o chão a fim de não danificar o produto;
- ➔ Evitar batidas e o contato com objetos cortantes;
- ➔ Observar carga máxima suportado pelo produto;

## **LIMPEZA**

- ➔ Pano levemente umedecido com água seguido de pano seco;
- ➔ Não utilizar produtos químicos e abrasivos;

## **ATENCIÓN**

- ➔ Lea y siga todas las instrucciones cuidadosamente antes de iniciar el montaje;
- ➔ El montaje del producto debe estar en una superficie limpia y plana;
- ➔ Recomienda utilizar el embalaje para cubrir el suelo con el fin de no dañar producto;
- ➔ Eviten los golpes y el contacto con objetos punzantes;

## **LIMPIEZA**

- ➔ Paño ligeramente humedecido con agua, seguido por un paño seco;
- ➔ No utilice productos químicos y abrasivos;

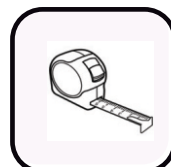
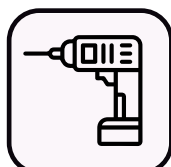





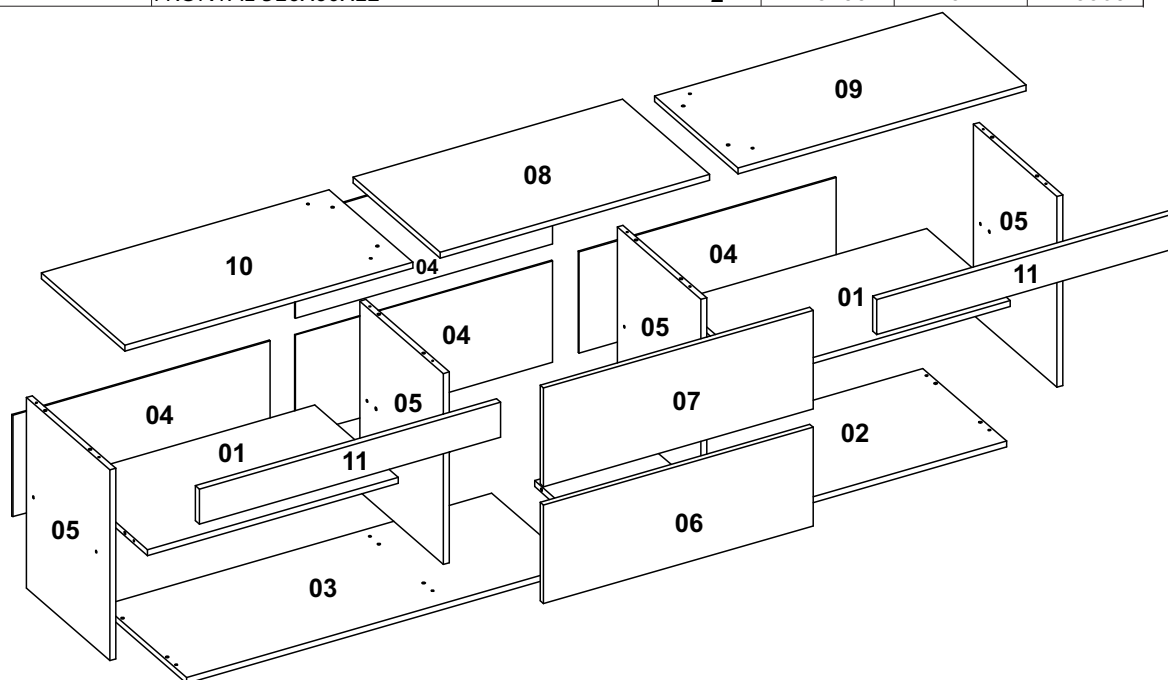



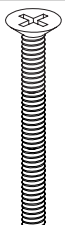

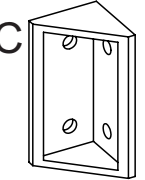
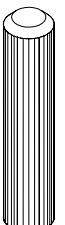

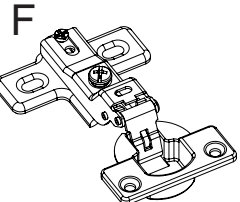

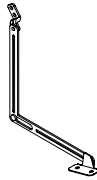
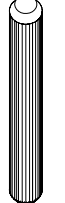

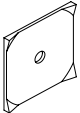
## Lista das Peças

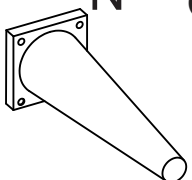
Nº DA PEÇA	DESCRIÇÃO	QTD	COD. BRANCO	COD. PRETO FOSCO	COD. CACAU
1	CHAPÉU 516X298X12	2	28134	28113	28553
2	CHAPÉU DIR 800X298X12	1	28135	28114	28554
3	CHAPÉU ESQ 800X298X12	1	28136	28115	28555
4	COSTA 530X209X3	4	28137	28116	28556
5	LATERAL 393X298X12	4	28138	28117	28557
6	PORTA 555X203X12	1	28141	28120	28558
7	TAMPO 555X203X12	1	28142	28121	28559
8	TAMPO 555X310X12	1	28143	28122	28560
9	TAMPO DIR 593X298X12	1	28144	28123	28561
10	TAMPO ESQ 593X298X12	1	28145	28124	28562
11	FRONTAL 516X60X12	2	28133	28127	28563

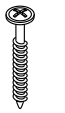

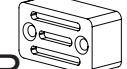
## Lista das Ferragens

4,0X40-Cod 3983	3,5x12-Cod 3385	20X20X42-Cod 23743	6x30-Cod 3881	6x20-Cod 26366	Cod 3384	10x10-Cod 3875	Cod 3872	
A 	B 	C 	D 	E 	F 	G 	H 	
x20	x72	x12	x24	x2	x2	x70	x1	
Cod 6705	Cod 8686	Cod 15356	Cod 3877	530MM-Cod 28131	Pé	6x20-Cod 26364	3,5X20-Cod 12025	
I 	J 	K 	L 	M 	N 	O 	P 	
x1	x2	x2	x6	x1	x5	x4	x4	
4,5X16-Cod 28550	Cod 23800	3,5x25-Cod 7182						
Q 	R 	S 						
x20	x8	x16						

3

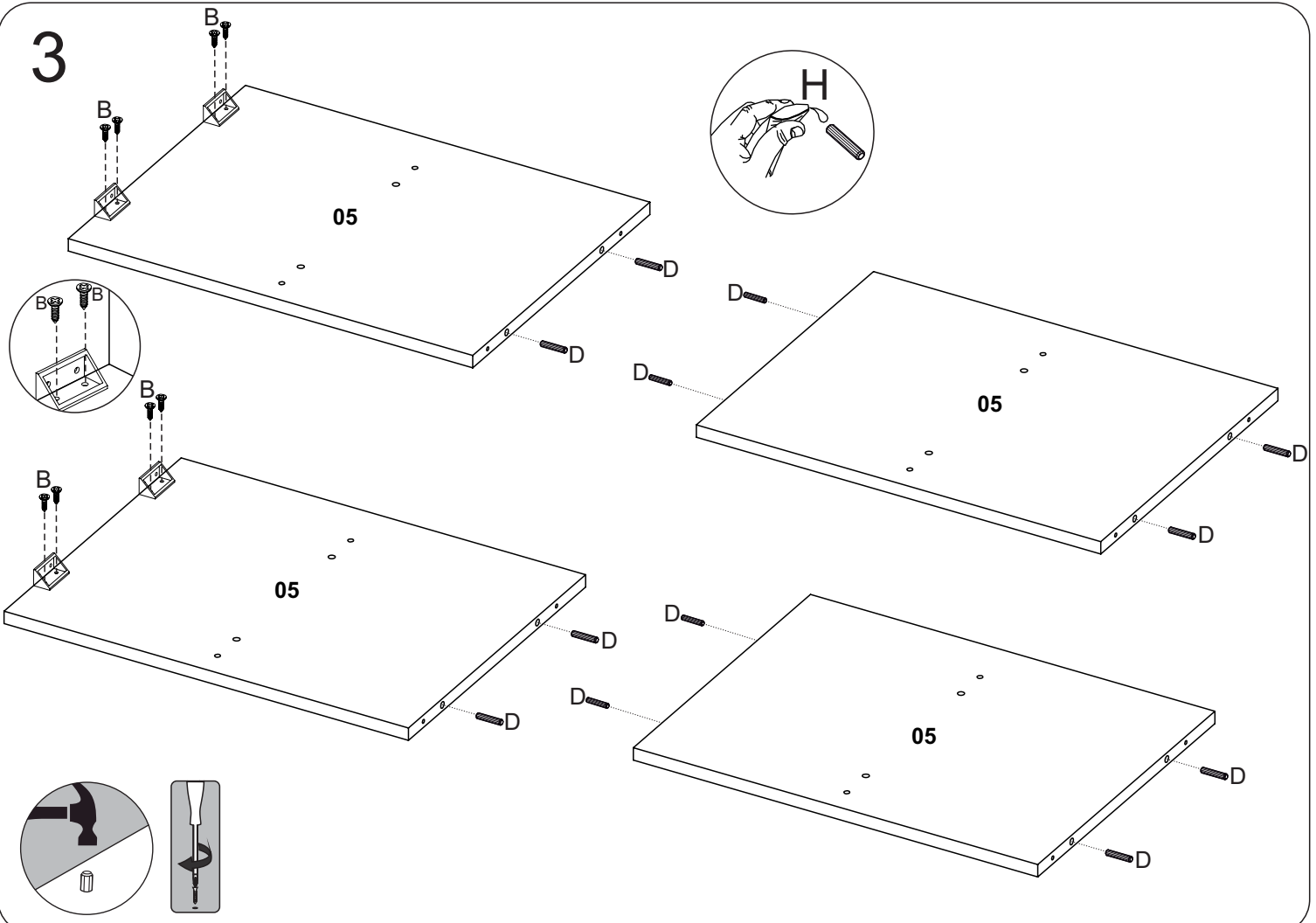

4

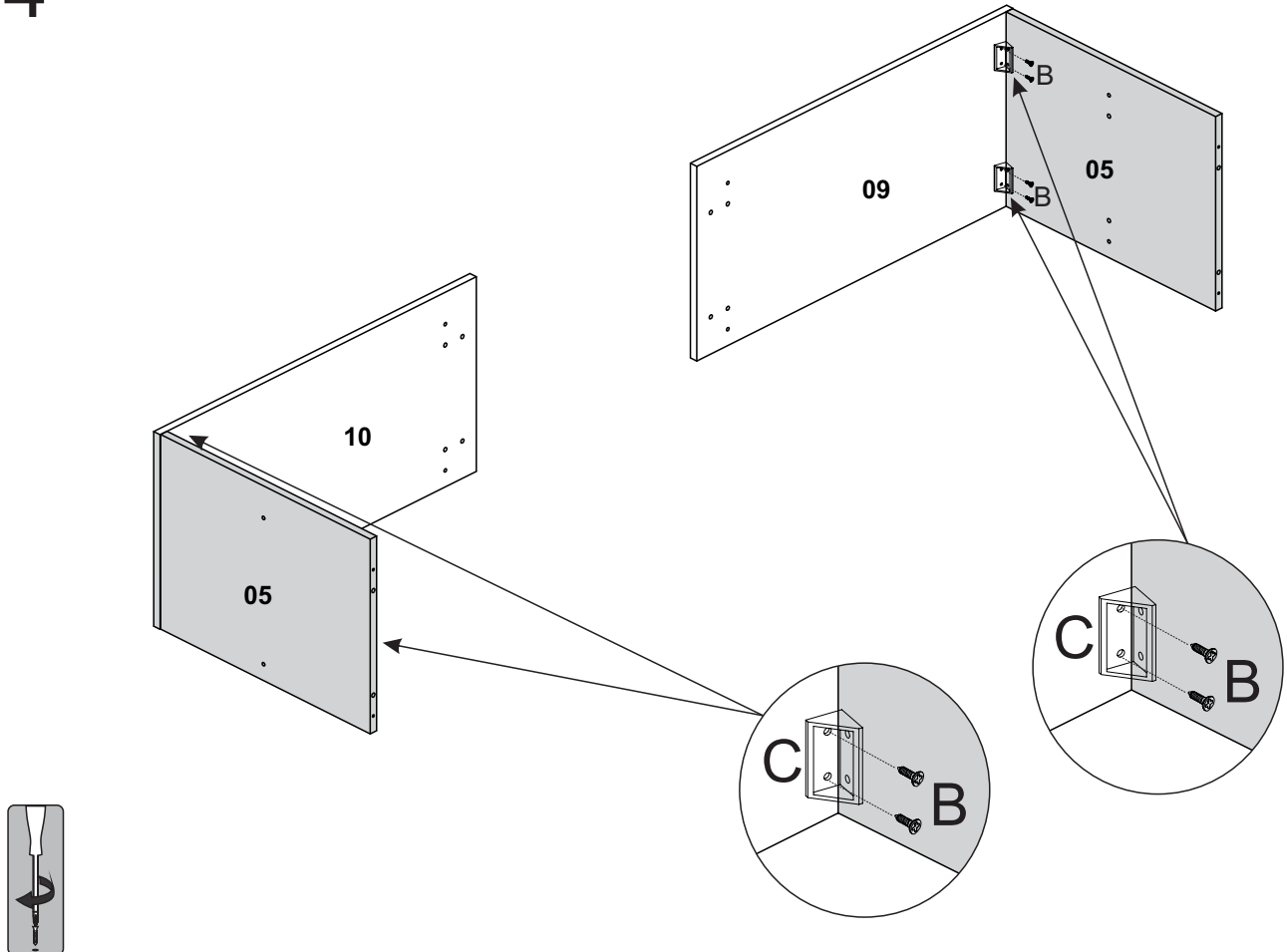

5

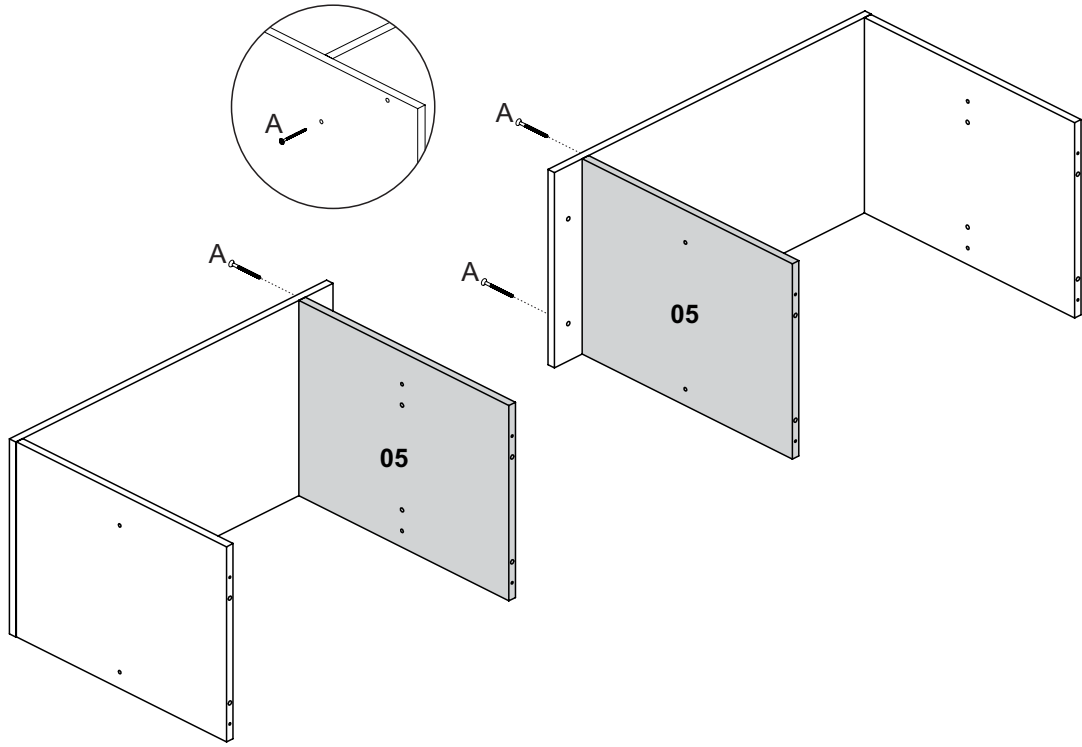

6

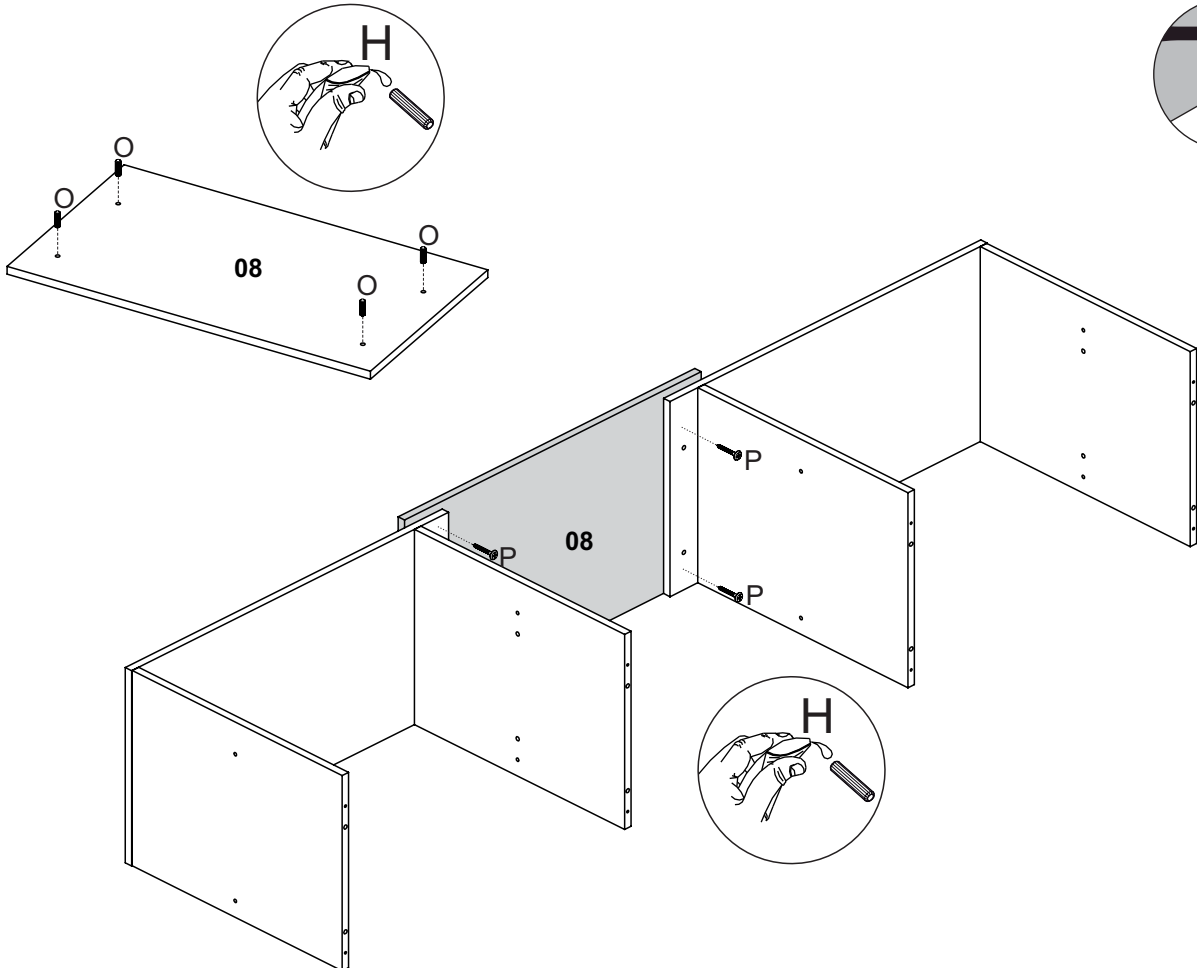

7

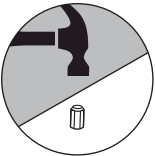
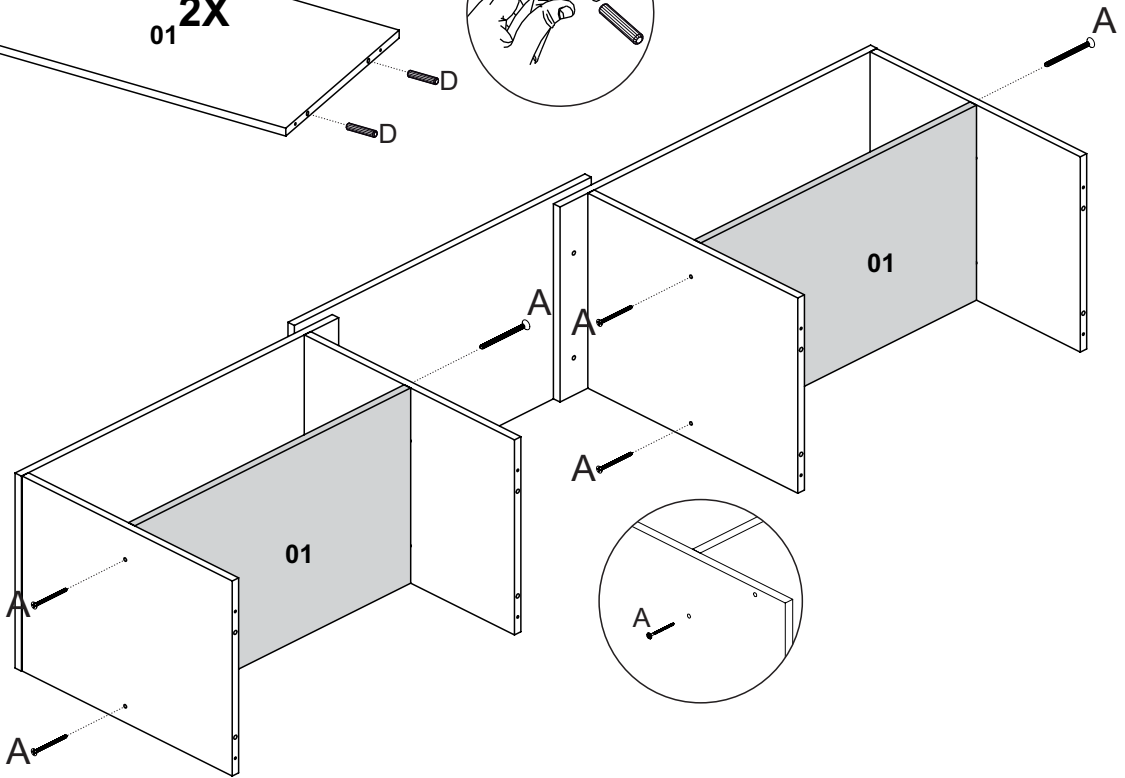
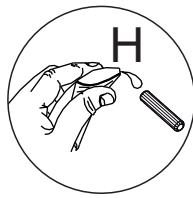
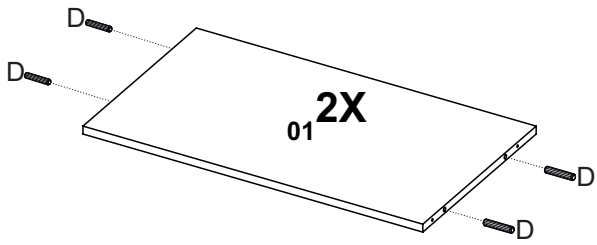

8

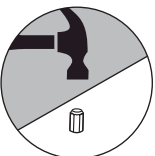
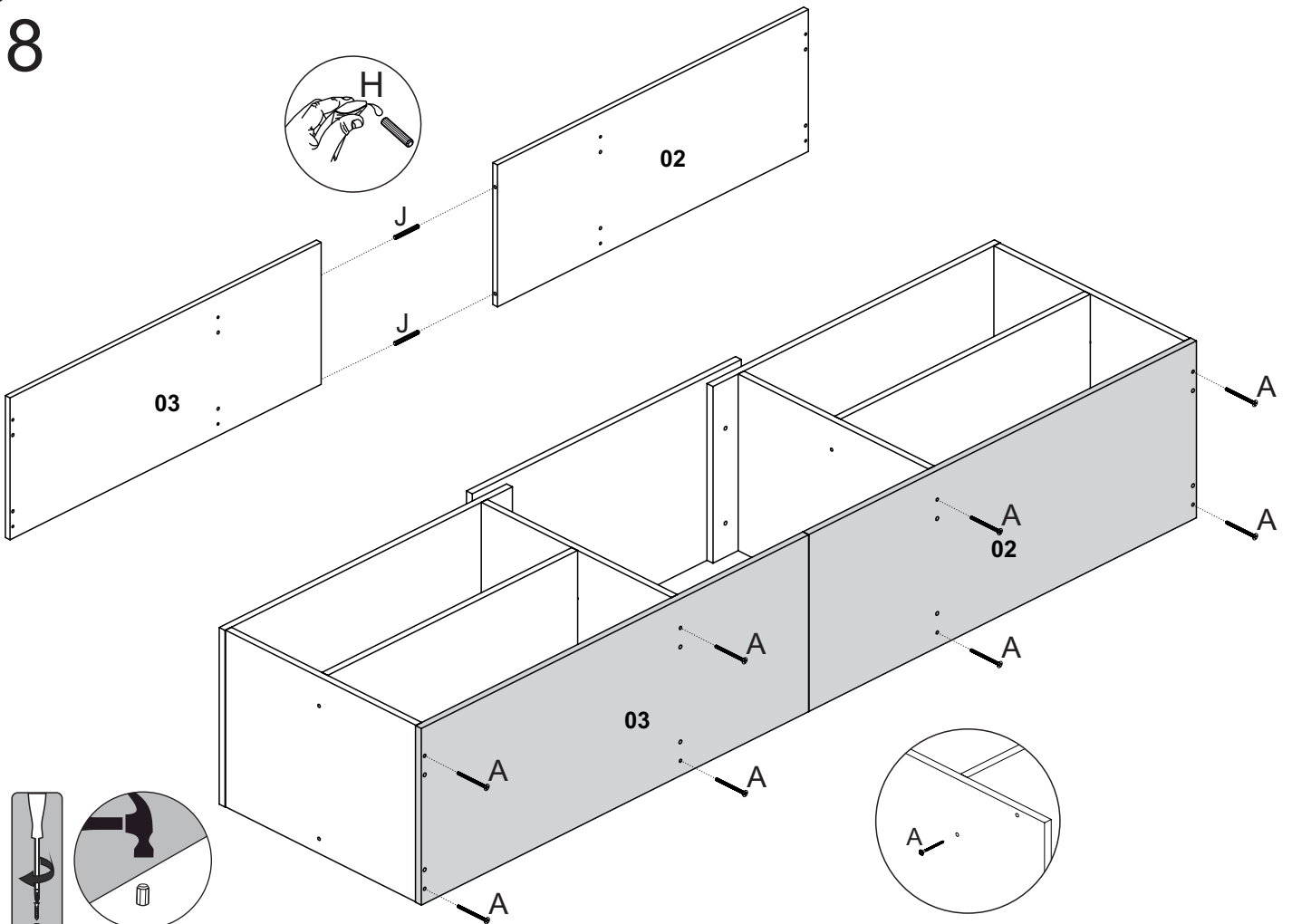

9

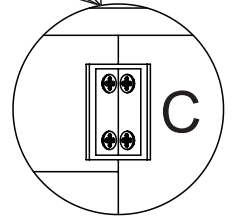
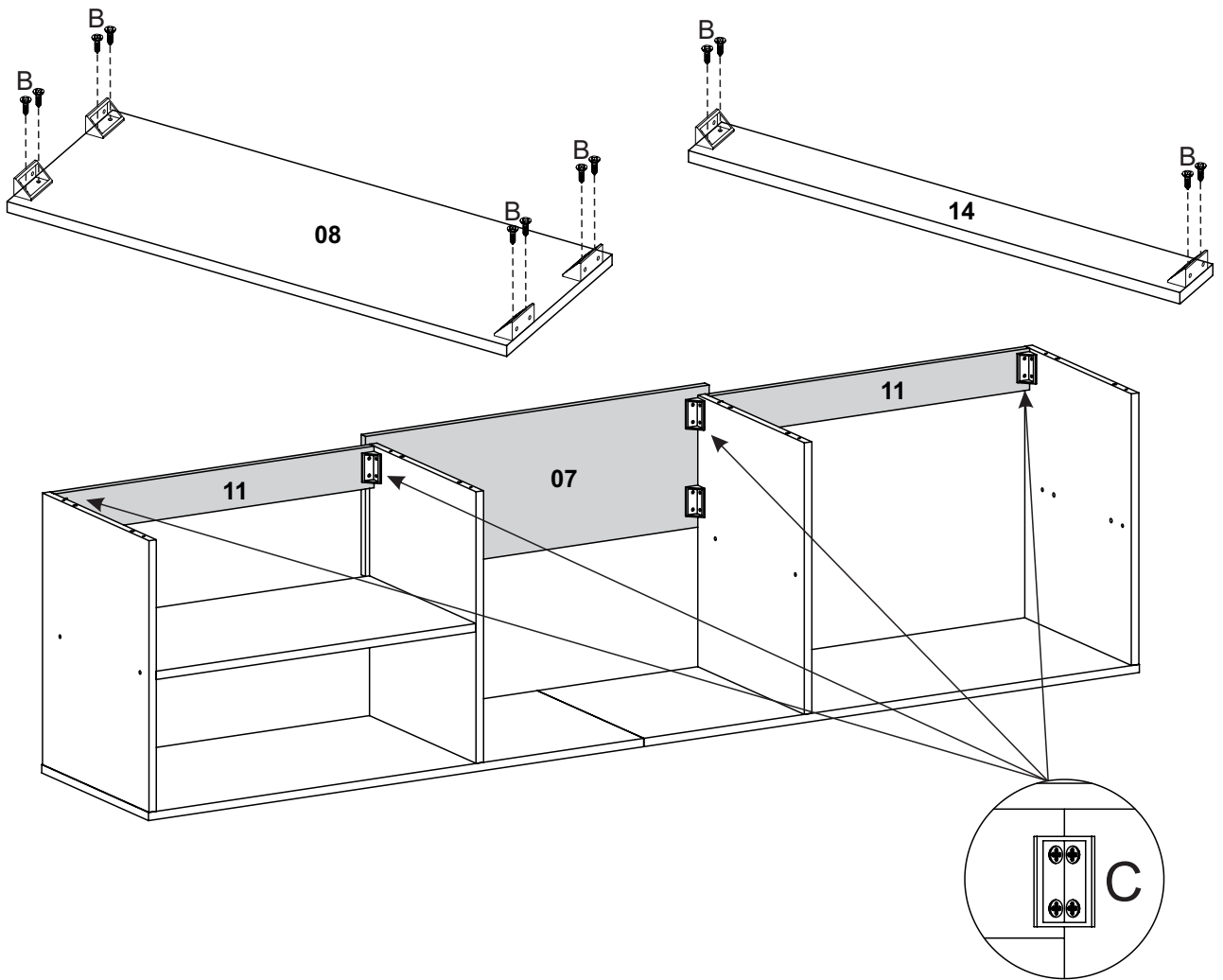

10

### Fixação dos pés (se adquirido)

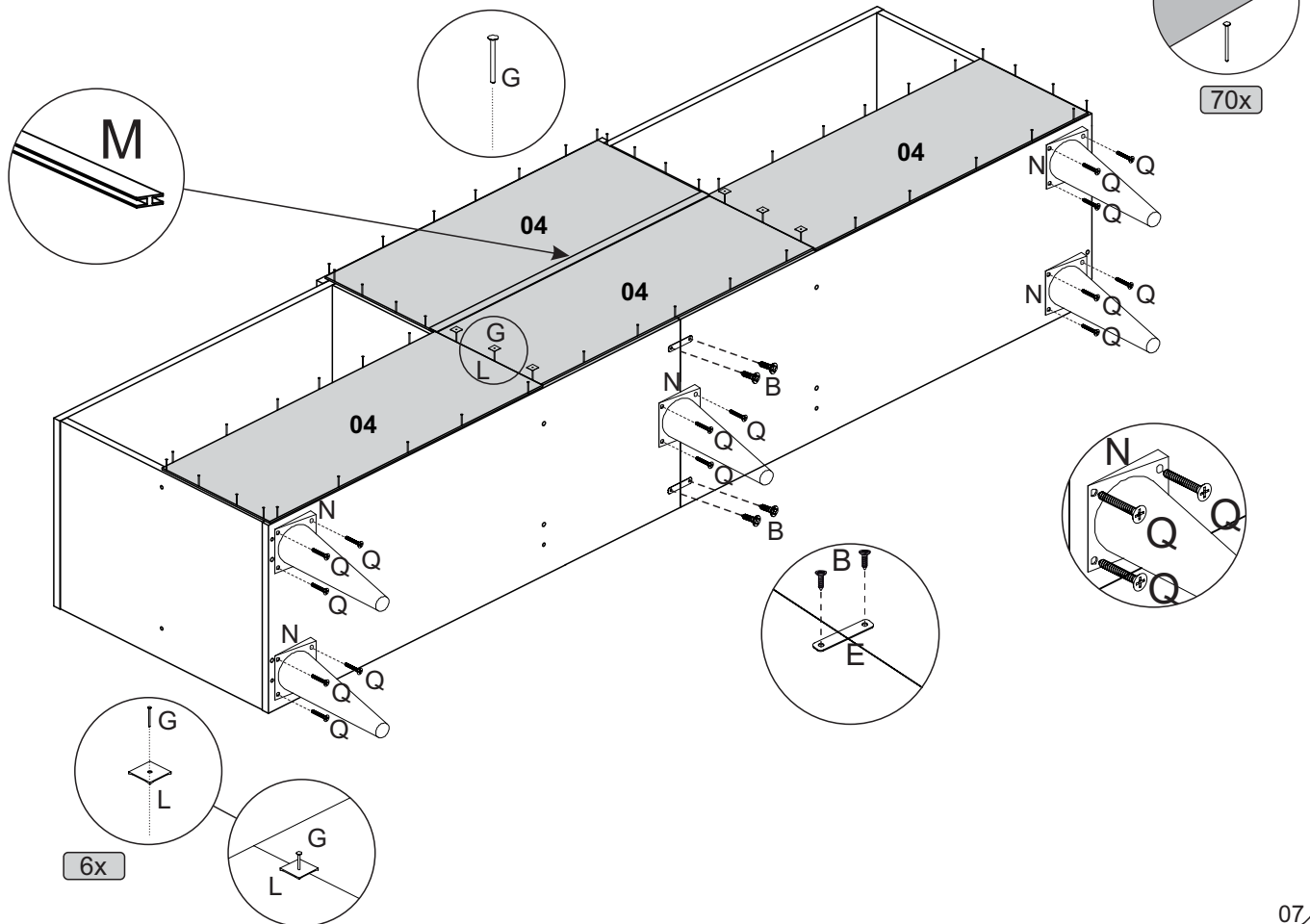

70x



6x

# Fixação das sapatas (se adquirido)

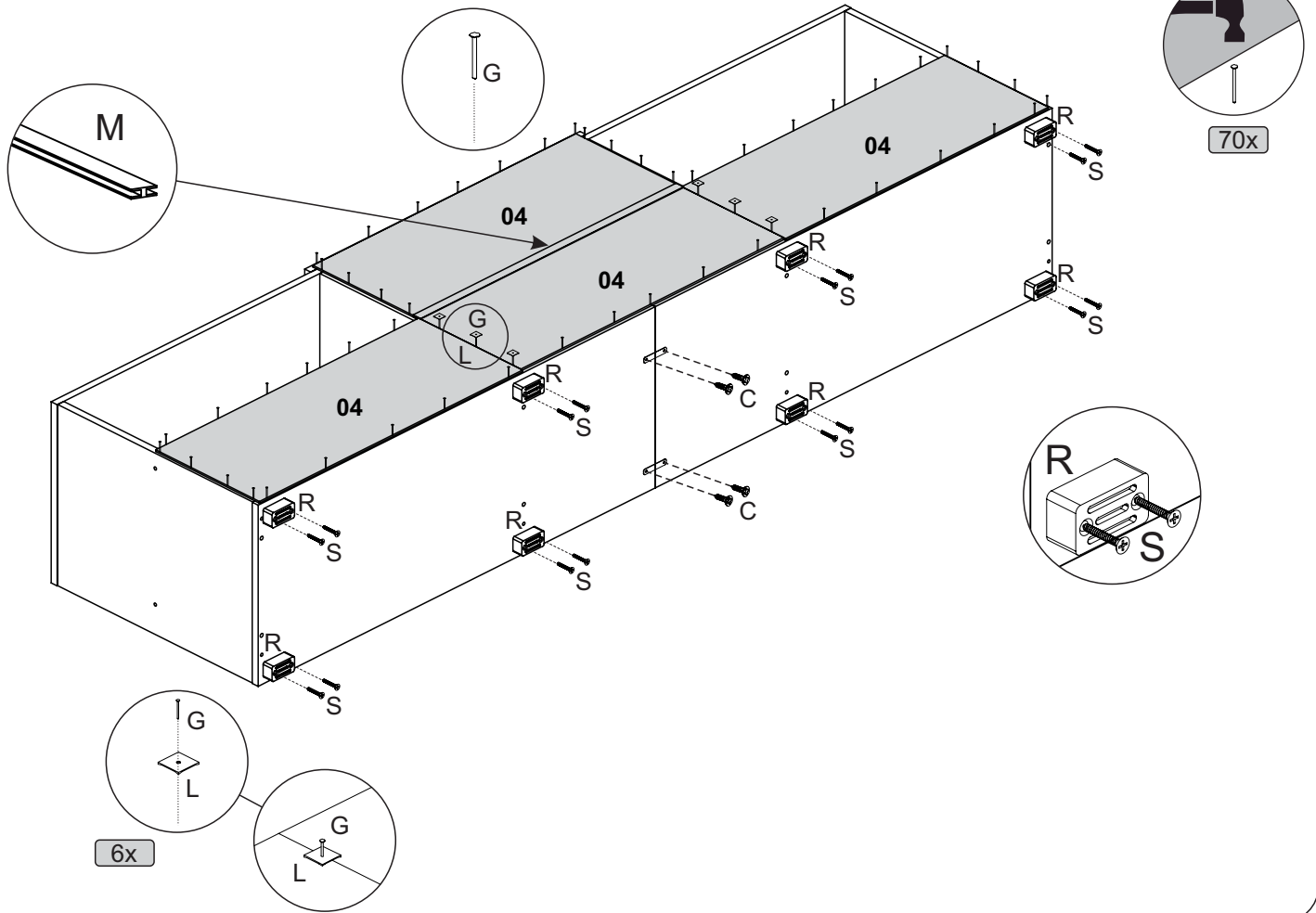

11

**Nota:** Utilizar o calço (K) na dobradiça (F)

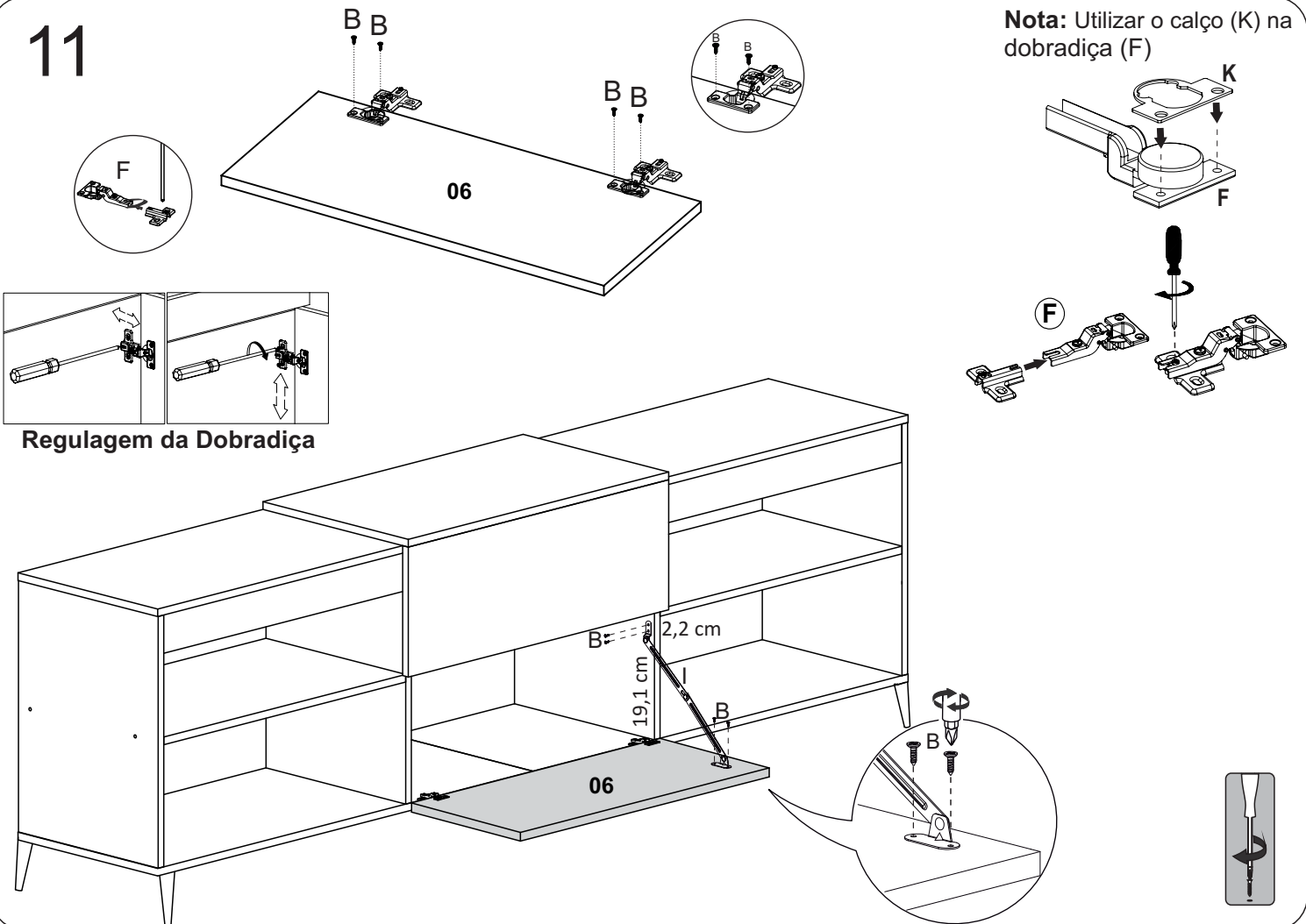

**Regulagem da Dobradiça**

2,2 cm  
19,1 cm

06

