

7012 - PANELEIRO DUPLO FORNO COLORS
 7012 - DOUBLE OVEN CUP BOARD COLORS
 7012 - ALACENA P/ DOBLE HORNO COLORS

kits paraná
 cozinhos inteligentes

ASPECTO MONTADO / ASSEMBLY ASPECT / ASPECTO LISTO

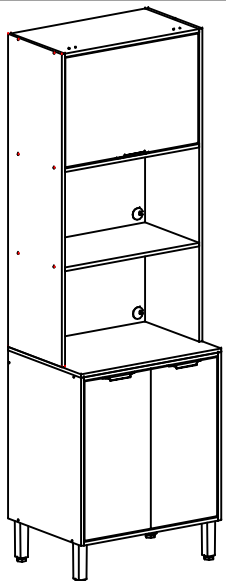

ASPECTO TRASEIRO / BOTTOM ASPECT / ASPECTO TRASERO

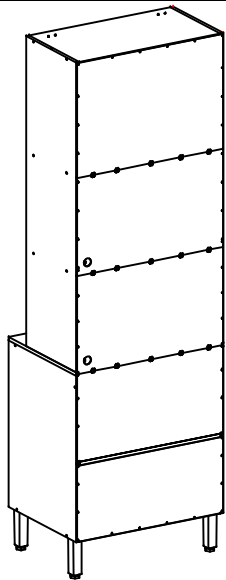

- PESSOAS NECESSÁRIAS P/ MONTAGEM.
 - REQUIRED PEOPLE FOR ASSEMBLY.
 - CANTIDAD DE PERSONAS NECESARIAS P/ ARMAR.



LISTA DE PEÇAS / LIST OF PIECE / LISTA DE PIEZAS

Nº	COD	NOME DA PEÇA / NAME OF THE PIECE / NOMBRE DE LA PIEZA	MEDIDA	QTDE	MAT. PRIMA
VOLUME 01					
01	116002	ACESSÓRIO DE MONTAGEM / ASSEMBLY ACCESSORY / ACCESORIO DE MONTAJE	-	01	DIVERSOS
02	903440	PERFIL H 670MM / PLASTIC PROFILE H 670MM / PERFIL H 670MM	670MM	01	PLÁSTICO
03	908640	PÉS / FEET / PATA	170MM	04	PLÁSTICO
04	116138.0662.0464	PORTA SUPERIOR / UPPER DOOR / PUERTA SUP	662x464x15	01	MDF
05	116123.0700.0520	TAMPO / COVER / TAPA	700x520x15	01	MDF
06	116124.0713.0520	LATERAL INF DIREITA / LOWER RIGHT LATERAL / LATERAL INF DERECHA	713x520x15	01	MDF
07	116125.0713.0520	LATERAL INF ESQUERDA / LOWER LEFT LATERAL / LATERAL INF IZQUIERDA	713x520x15	01	MDF
08	116128.0670.0503	PRATELEIRA I INF / LOWER I SHELF / REPISA I INF	670x503x15	01	MDF
09	116129.0670.0520	BASE II / BASE II / BASE II	670x520x15	01	MDF
10	116139.0695.0492	TRASEIRO SUPERIOR / UPPER BOTTOM / TRASERO SUP	695x492x03	01	MADEFIBRA
11	116140.0695.0420	TRASEIRO CENTRAL / CENTRAL BOTTOM / TRASERO CENTRAL	695x420x03	02	MADEFIBRA
12	116131.0695.0382	TRASEIRO INF MAIOR / UPPERSIZED LOWER BOTTOM / TRASERO INF MAYOR	695x382x03	01	MADEFIBRA
13	116132.0695.0331	TRASEIRO INF MENOR / DOWNSIZED LOWER BOTTOM / TRASERO INF MENOR	695x331x03	01	MADEFIBRA
VOLUME 02					
14	116136.1327.0385	LATERAL SUP DIREITA / UPPER RIGHT LATERAL / LATERAL SUP DERECHA	1327x385x15	01	MDF
15	116137.1327.0385	LATERAL SUP ESQUERDA / UPPER LEFT LATERAL / LATERAL SUP IZQUIERDA	1327x385x15	01	MDF
16	116157.0670.0385	CHAPÉU / HAT / CUBIERTA	670x385x15	01	MDF
17	116121.0670.0385	BASE I - PRATELEIRA II / SHELF II - BASE I / BASE I - REPISA II	670x385x15	02	MDF
18	116126.0670.0070	SUPORE TRASEIRO / BOTTOM SUPPORT / APOYO TRASERO	670x70x15	01	MDF
19	116127.0670.0070	SUPORE FRONTAL / FRONT SUPPORT / APOYO FRONTAL	670x70x15	01	MDF
VOLUME 03					
20	116130.0675.0331	PORTA INFERIOR / LOWER DOOR / PUERTA INF	675x331x15	02	MDP - BP

CÓDIGOS IDENTIFICADOS NO TOPO DA MAIORIA DAS PEÇAS DO PRODUTO.
 THESE CODES ARE IDENTIFIED ON THE SIDE OF MOST PARTS OF THE PRODUCT.
 CÓDIGO IMPRESO EN EL CANTO CRUDO DE LA MAYORIA DE LAS PIEZAS.



ATENÇÃO / ATTENTION / ATENCIÓN:

- A LIMPEZA DO MÓVEL DEVE SER EFETUADA SOMENTE COM PANO MACIO E MODERADAMENTE UMEDECIDO COM ÁGUA PURA OU SOLUÇÃO COM SABÃO NEUTRO.
- FOR CLEANING, USE ONLY A SOFT CLOTH MODERATELY MOISTENED WITH PURE WATER OR A SOLUTION WITH NEUTRAL SOAP.
- PARA LIMPIEZA DEL MUEBLE USAR UN PAÑO SUAVE Y MODERADAMENTE HUMEDECIDO CON AGUA PURA O SOLUCIÓN CON JABÓN NEUTRO.
- NÃO UTILIZE PRODUTOS QUÍMICOS OU ABRASIVOS, TAIS COMO: CERA, ÁLCOOL, DETERGENTES, TINNER.
- DO NOT USE CHEMICAL OR ABRASIVE PRODUCTS. FOR EXAMPLE: WAX, ALCOHOL, DETERGENT, THINNER.
- NO APLICAR PRODUCTOS QUÍMICOS O ABRASIVOS TALES COMO: CERAS, ALCOHOL, DISOLVENTES O DETERGENTES.
- AO SOLICITAR ASSISTÊNCIA TÉCNICA, INFORME O CÓDIGO DO PRODUTO, A COR E O CÓDIGO DA PEÇA CORRETAMENTE.
- WHEN REQUESTING TECHNICAL ASSISTENCE, INFORM THE PRODUCT CODE, THE COLOR AND THE PIECE CODE CORRECTLY.
- SI NECESITAR REPUESTOS, INFORMAR EL CÓDIGO DEL PRODUCTO, EL COLOR Y EL CÓDIGO DE LA PIEZA.

FERRAMENTAS NECESSÁRIAS P/ MONTAGEM.



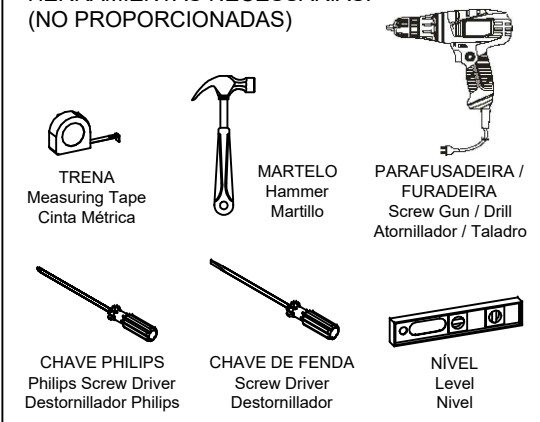







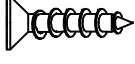

(NÃO SÃO FORNECIDAS)
 REQUIRED TOOLS FOR ASSEMBLY.
 (NOT PROVIDED)
 HERRAMIENTAS NECESARIAS.
 (NO PROPORCIONADAS)





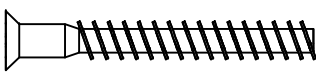

7012 - PANELEIRO DUPLO FORNO COLORS
 7012 - DOUBLE OVEN CUP BOARD COLORS
 7012 - ALACENA P/ DOBLE HORNO COLORS

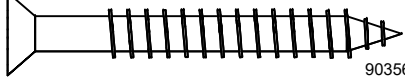



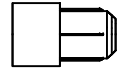
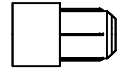
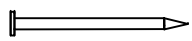
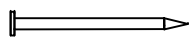
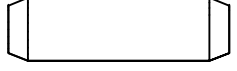
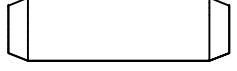

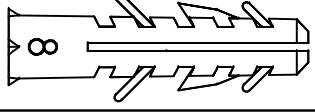
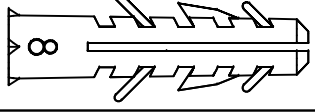

kits paraná
 cozinh@inteligentes

LISTA DE ACESSÓRIO / ACCESSORY LIST / LISTAJE DE ACCESORIO - 1X1

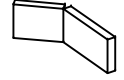
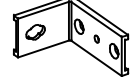
		A 14 911268 - PARAFUSO 3,5X12 CHATA 6.1
		B 02 914127 - PARAFUSO 3,5X16
		C 06 909192 - PARAF. 3,5X25 CABEÇA CHATA
		D 04 903571 - PARAF. M4X25
		E 04 903557 - PARAF. 5,0X35 FLANGEADO
		F 24 903566 - PARAF. 5,0X40
		G 02 903563 - PARAF. 6,0X50

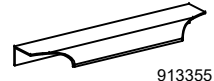
		H 04 905126 - PORCA SEXTAVADA M4
		I 04 904980 - SUPORTE DE PRATELEIRA 8X10
		J 68 904801 - PREGO 09X09
		K 24 902913 - CAVILHA 8X30
		L 02 902915 - CAVILHA 8X50
		M 02 900053 - BUCHA 08

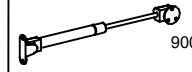
LISTA DE ACESSÓRIO / ACCESSORY LIST / LISTAJE DE ACCESORIO

	N 02 902900 - CANTONEIRA PARA VISTA		S 15 900456 - FIXADOR P/ FUNDO
	O 02 901635 - FIXADOR L CAPA PLÁSTICA		T 02 903341 - FIXADOR L CANT. METÁLICA
	P 03 915141 - KIT DOB. SUPER ALTA SLOW C/ 2		U 03 913355 - PUXADOR
	Q 02 900970 - PASSA FIO		V 02 900431 - SUPORTE A GÁS
	R 02 915242 - BATENTE DISTANCIADOR		

ESTRUTURA / STRUCTURE / ESTRUCTURA

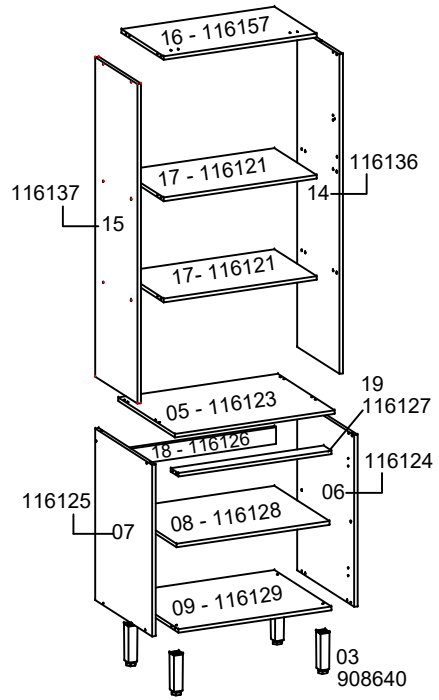

TRASEIRO / BOTTOM / TRASERO

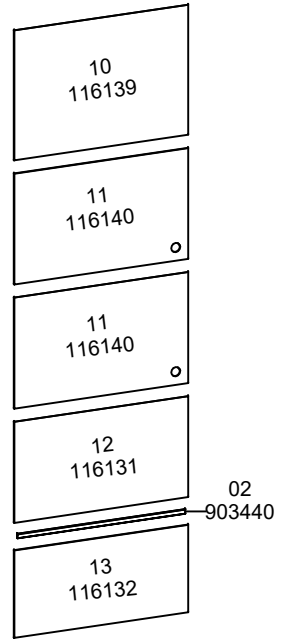

FRENTE / FRONT / FRENTE

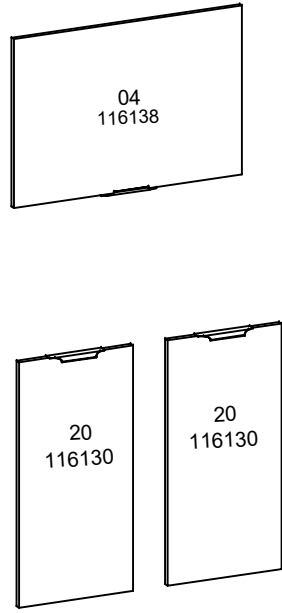

* imagens meramente ilustrativas *
 DATA: 10/02/2026 - REVISÃO: 00 - ULTIMA ALTERAÇÃO: 00/00/0000 - PAG: 02/04

- A** 02
PARAFUSO 3,5X12
- E** 04
PARAFUSO 5,0X35
- F** 08
PARAFUSO 5,0X40
- I** 04
SUPORTE DE PRATELEIRA
- K** 10
CAVILHA 8X30
- N** 02
CANTONEIRA METALICA

① MONTAGEM DA ESTRUTURA INFERIOR.
 LOWER STRUCTURE ASSEMBLY.
 MONTAJE DE LA ESTRUCTURA INFERIOR.

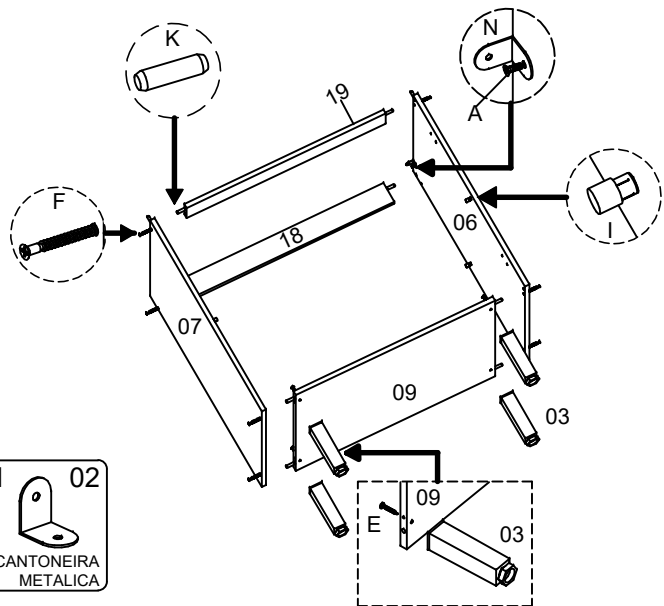

③ FIXAÇÃO DA ESTRUTURA INF. C/ A SUP.
 UPPER STRUCTURE ATTACHMENT INTO LOWER.
 FIJACIÓN DE LA ESTRUCTURA INF. CON LA SUP.

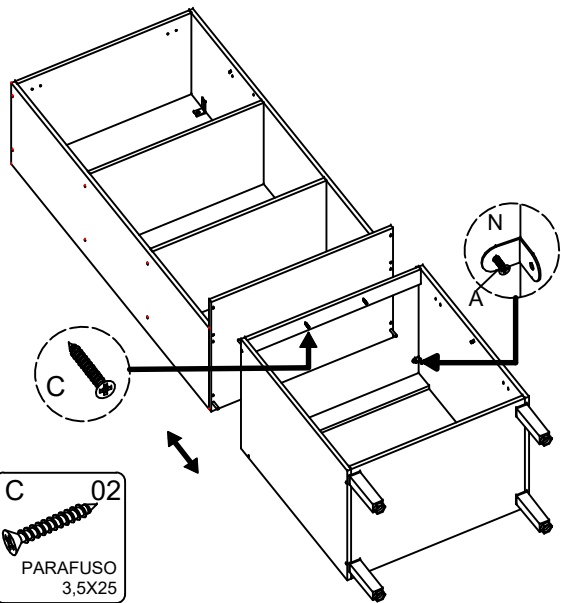

- A** 02
PARAFUSO 3,5X12
- C** 02
PARAFUSO 3,5X25

② MONTAGEM DA ESTRUTURA SUPERIOR.
 UPPER STRUCTURE ASSEMBLY.
 MONTAJE DE LA ESTRUCTURA SUPERIOR.

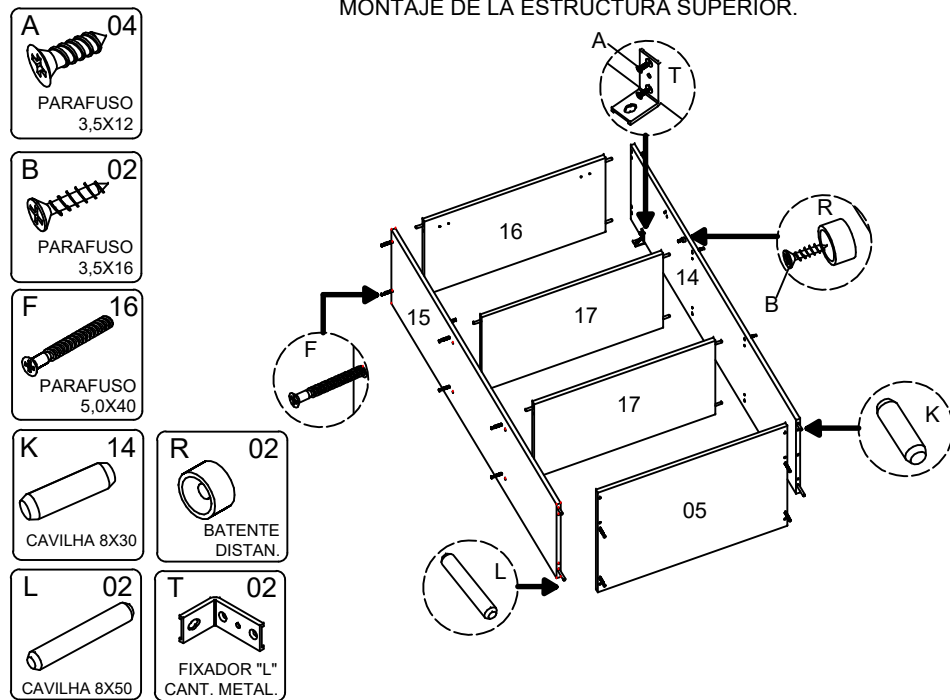

- A** 04
PARAFUSO 3,5X12
- B** 02
PARAFUSO 3,5X16
- F** 16
PARAFUSO 5,0X40
- K** 14
CAVILHA 8X30
- L** 02
CAVILHA 8X50
- R** 02
BATENTE DISTAN.
- T** 02
FIXADOR "L" CANT. METAL.

④ FIXAÇÃO DOS TRASEIROS.
 BOTTOMS ATTACHMENT.
 FIJACIÓN DE LOS TRASEROS.

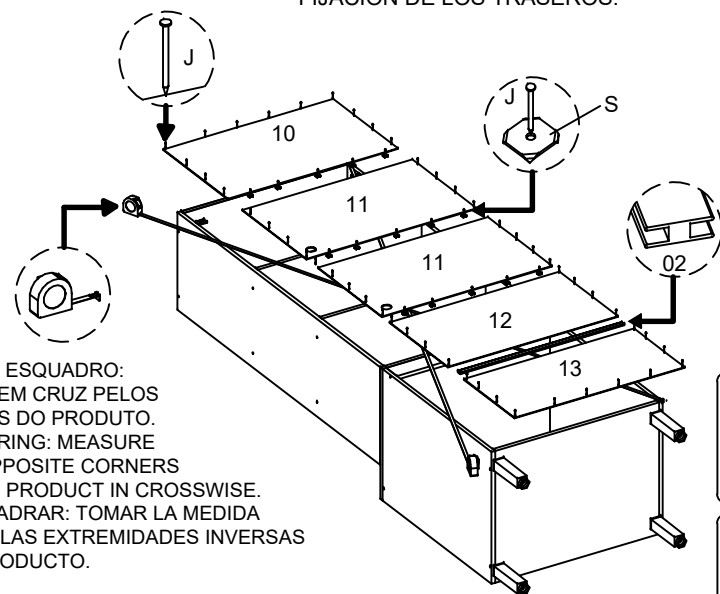

- TIRAR ESQUADRO:
 MEDIR EM CRUZ PELOS
 CANTOS DO PRODUTO.
 - SQUARING: MEASURE
 THE OPPOSITE CORNERS
 OF THE PRODUCT IN CROSSWISE.
 - ESCUADRAR: TOMAR LA MEDIDA
 ENTRE LAS EXTREMIDADES INVERSAS
 DEL PRODUCTO.

- J** 68
PREGO 09X09
- S** 15
FIXADOR P/
FUNDO

⑤ COLOCAÇÃO DAS DOBRADIÇAS E PUXADORES.
 HINGE AND HANDLES ATTACHMENT.
 FIJACIÓN DE LAS MANIJAS Y BISAGRA .

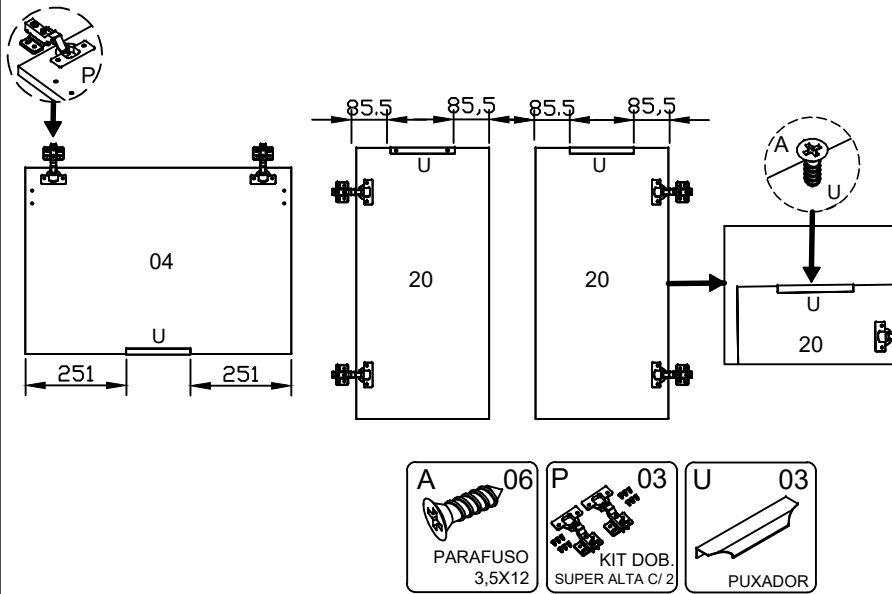

- * LIMITE DE PESO MÁXIMO SUPORTADO (KG).
- * WEIGHT CAPACITY (KG).
- * CAPACIDAD DE PESO (KG).

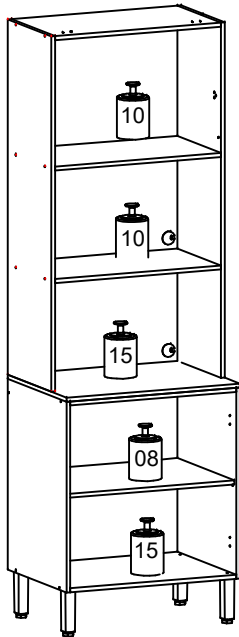

- CONSIDERAR UM PESO BEM DISTRIBUÍDO POR TODO O PRODUTO.
- CONSIDER A WELL DISTRIBUTED WEIGHT IN ALL THE PRODUCT.
- CONSIDERAR UN PESO BIEN DISTRIBUIDO EN TODO EL PRODUCTO.

⑥ COLOCAÇÃO DAS PORTAS E PRATELEIRA I.
 DOORS AND SHELF I PLACEMENT.
 COLOCACIÓN DE LAS PUERTAS Y REPISA I.

- VERIFICAR O NÍVEL DO PRODUTO, SE NECESSÁRIO FAZER AJUSTE DOS PÉS REGULÁVEIS.
 - CHECK THE PRODUCT'S LEVELING, IF IT'S NECESSARY MAKE AN ADJUSTMENT ON THE ADJUSTABLE FEET.
 - VERIFICAR LA NIVELACIÓN DEL PRODUCTO, SI ES NECESARIO REALIZAR UN AJUSTE EN LOS PIES REGULABLES.

- COLOCAÇÃO DA PORTA BASCULANTE.
- HORIZONTAL DOOR PLACEMENT.
- COLOCACIÓN DE LA PUERTA HORIZONTAL.

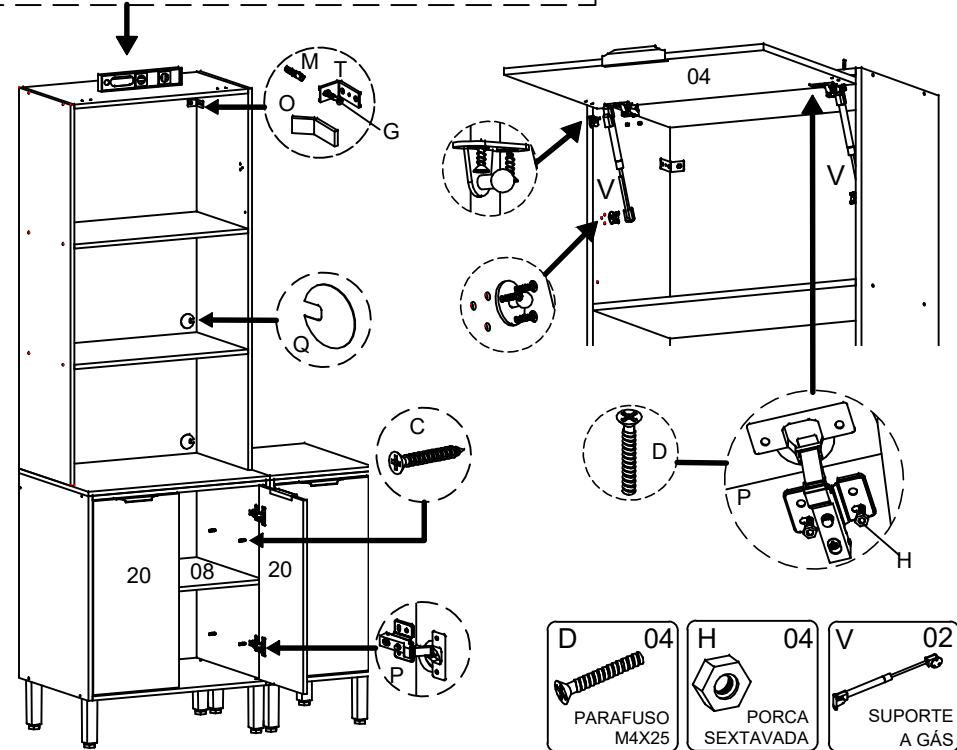

- PARA UNIÃO DOS MÓDULOS, FAZER USO DO PARAF. 3,5X25 (C).
- FOR THE MODULES UNION, USE SCREW 3,5X25 (C).
- PARA LA UNIÓN DE LOS MÓDULOS, USE EL TORNILLO 3,5X25(C).

- INFORMAÇÃO AO MONTADOR: USAR PARAFUSADEIRA NO TORQUE BAIXO!
- INFORMATION TO THE ASSEMBLER: USE THE CORDLESS DRILL AT LOW TORQUE.
- INFORMACIÓN AL ARMADOR: UTILIZAR ATORNILLADOR EN TORQUE FLACO.

