

MANUAL TÉCNICO 1001 SOUL

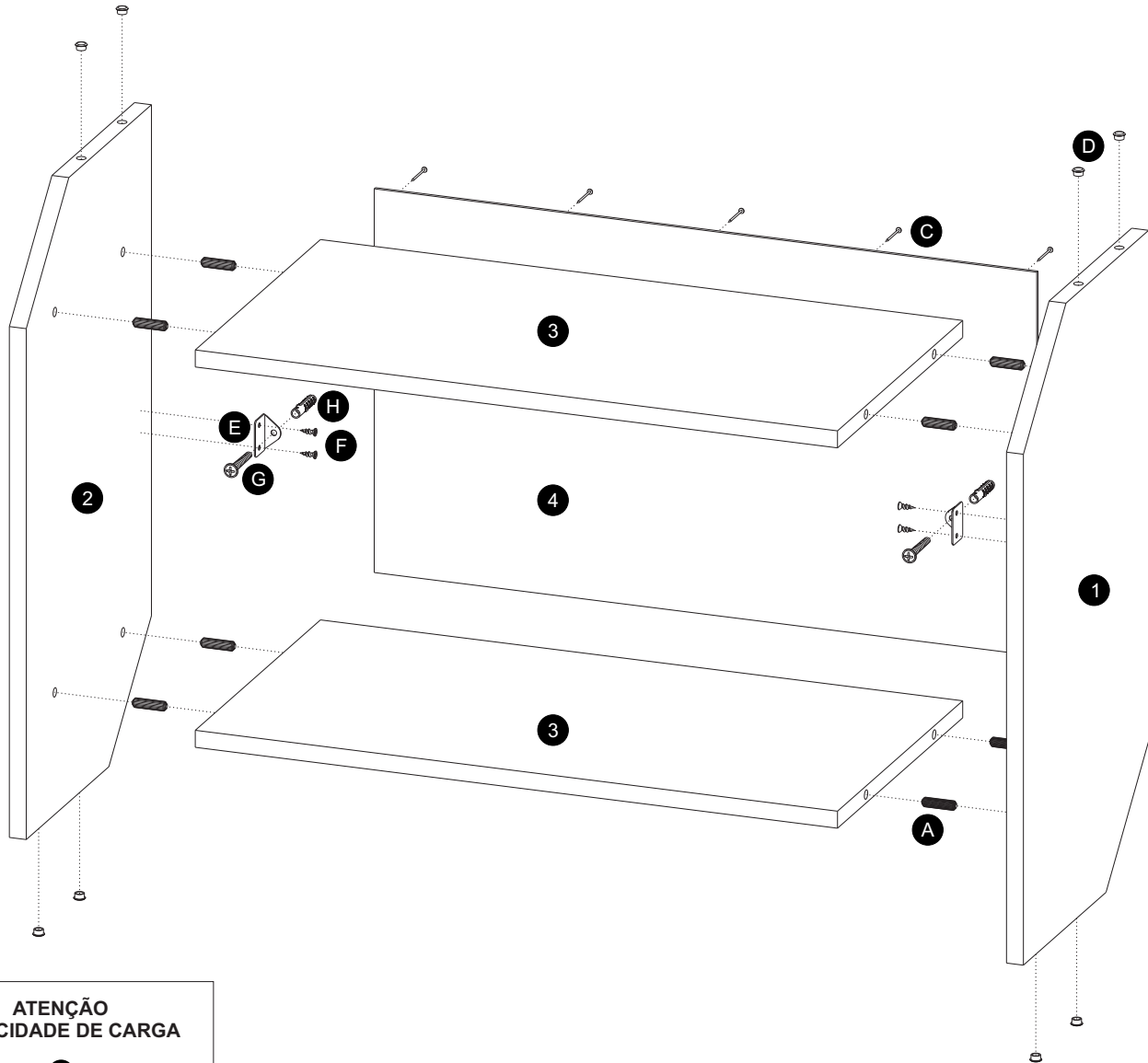







Identificação dos componentes

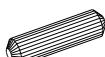

**ATENÇÃO
CAPACIDADE DE CARGA**



Total: 25 KG DISTRIBUINDOS

COMPONENTES		FERRAGENS					
1	Lateral dir.	A	Cavilha 8x30 mm	A		B	
2	Lateral esq.	B	Cola	C		D	
3	Teto Base	C	Prego	E		F	
4	Costa	D	Tapa furo 8 mm	G		H	
		E	Chapa de fixação				
		F	Parafuso cabeça chata 3,5x14 mm				
		G	Parafuso cabeça flangeada 4x50 mm				
		H	Bucha de nylon 8x40 mm				

1º ETAPA

Utilizando Cavilhas 8 mm (Comp. A) e Cola (comp. B) fixe a Lateral dir. (Comp. 1) e a Lateral esq. (Comp. 2) no Teto|Base (Comp. 3).

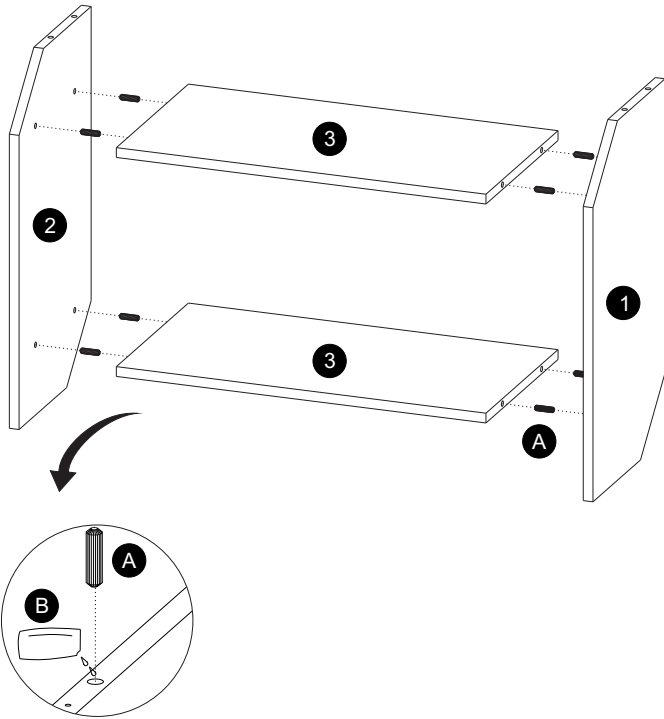

É INDISPENSÁVELA UTILIZAÇÃO DE COLA!

2º ETAPA

Utilizando Prego (Comp. C), fixe a Costa (Comp. 4) na parte posterior do módulo.

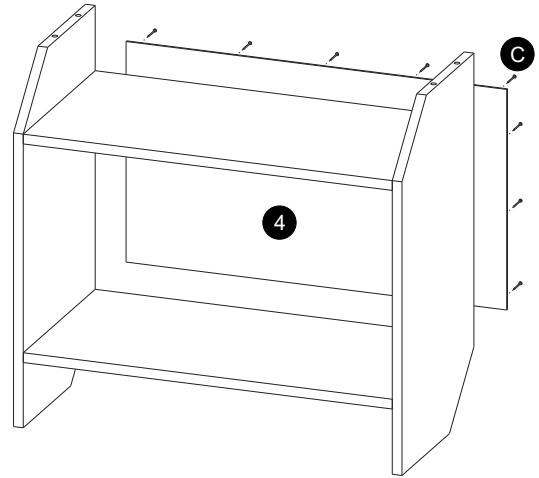

ATENÇÃO

Deixe a cola secar por 24 horas.

3º ETAPA

Encaixe os tapa furo (Comp. D) na parte superior e inferior das laterais (Comp. 1) e (Comp.2).

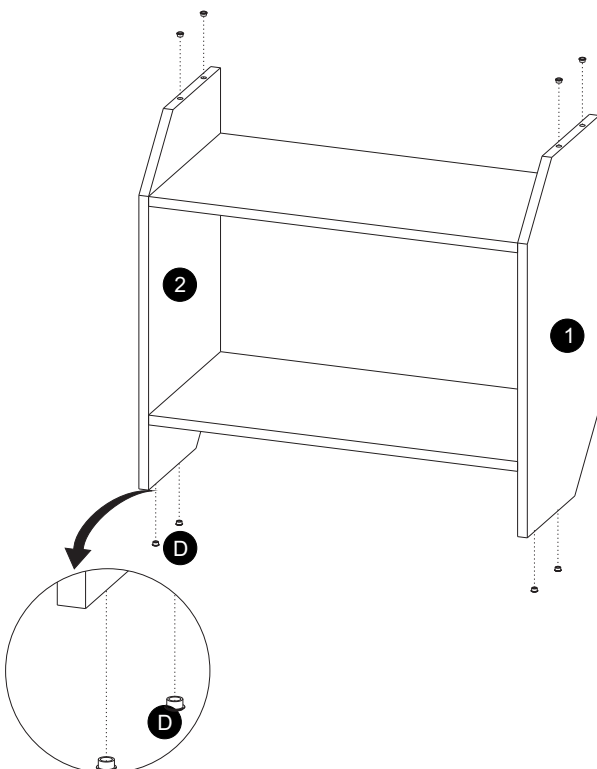

4º ETAPA

Utilizando Parafuso cabeça chata 3,5x14 (Comp. F) fixe a chapa de fixação (Comp E) nas Laterais (Comp. 1) e (Comp. 2), em seguida utilizando parafuso cabeça frangeada 4x50 mm (Comp. G) e Bucha de nylon (Comp. H) fixe o módulo no local desejado.

