

Mesa Tamburato Supreme - LD Escritorio Tamburato Supreme- LD Tamburato Supreme Desk - RS

- Siga atentamente todas as instruções de montagem;
- Monte seu produto no local ou próximo de onde será colocado. Movimentações do produto já montado, podem avariá-lo;
- Faça a montagem em uma superfície limpa e plana. Aconselhamos usar a própria embalagem de papelão para forrar o chão;
- Verifique se as quantidades de peças e acessórios estão de acordo com o manual de montagem;
- Compare atentamente os furos de cada peça com a ilustração do manual;
- Utilize as ferramentas indicadas. Só utilize parafusadeira se tiver conhecimento e habilidade. O uso inapropriado pode danificar peças e/ou acessórios;
- Se o produto necessitar fixação na parede, tenha cuidado para não atingir fios e canos ao furar a parede.

Obs: Caso necessite solicitar peças de reposição, por favor, utilize os códigos dos mesmos.

- *Siga con atención todas las instrucciones de armado.*
- *Arme su mueble en un lugar cerca donde será instalado. Mover el producto ya montado puede perjudicarlo.*
- *Haga el montaje en una superficie limpia y plana. Aconsejamos usar el propio embalaje de cartón para forrar el suelo.*
- *Asegúrese de que las cantidades de piezas y accesorios coincidan con el manual de montaje.*
- *Compare cuidadosamente los agujeros de cada pieza con la ilustración del manual.*
- *Utilice las herramientas indicadas. Sólo utilice atornillador automático si tiene conocimiento y habilidad. El uso inapropiado puede dañar piezas y/o accesorios.*
- *Si el producto necesita fijación en la pared, tenga cuidado de no alcanzar cables y tuberías al perforar la pared.*

OBS: Si necesita solicitar piezas y / o accesorios de repuesto, por favor, utilice los códigos de los mismos.

- *Follow carefully the assembly instructions.*
- *Assemble your furniture in a place near where it will be installed. Moving the assembled product can harm it.*
- *Make the assembly on a clean and flat surface. We recommend using the cardboard box to cover the floor.*
- *Make sure the quantities of parts and accessories match the assembly manual.*
- *Carefully compare the holes in each piece with the illustration in the manual.*
- *Use the indicated tools. Only use an automatic screwdriver if you have knowledge and skill. Improper use can damage parts and/or accessories.*
- *If the product needs fixing on the wall, be careful and don't reach cables and pipes when drilling the wall.*

NOTE: If you need to request spare parts and/or accessories, please use the codes according of this instruction manual.

CONSERVAÇÃO E LIMPEZA

MANTENIMIENTO Y LIMPIEZA / MAINTENANCE AND CLEANING

Não expor o produto ao sol, altas temperaturas e umidade, mantendo-o em local seco e arejado. Para a limpeza, utilizar um pano seco e macio. Não é necessário o uso de materiais abrasivos ou álcool.

No exponga el producto al sol, altas temperaturas y la humedad. Mantener en local seco y ventilado. Para limpiar, utilice un paño suave y seco. No es necesario el uso de materiales abrasivos o alcohol.

Do not expose the product to sunlight, high temperatures and humidity. Keep it in a dry and ventilated place. To clean it, use a soft and dry cloth. It is not necessary to use abrasive materials or alcohol.

Garantia

Este certificado de Garantia é uma vantagem adicional oferecida ao consumidor, porém para que o mesmo tenha validade é imprescindível que seja apresentada a NOTA FISCAL de compra do produto e o número do lote (ver etiqueta).

Com este produto, a Artany tem como objetivo atender plenamente o proprietário-consumidor, proporcionando a garantia na forma aqui estabelecida, pelo período de 2 anos a partir da data da nota fiscal de compra. A Artany restringe a sua responsabilidade à substituição gratuita das peças defeituosas, em caso de defeitos ou avarias devidamente constatados como sendo de fabricação, durante a vigência desta garantia.

A Artany declara a garantia nula e sem efeito se o produto for alterado, adulterado, molhado ou consertado e ainda pela prática de montagem inadequada. Também será considerada nula em casos de força maior, como aqueles causados por agentes da Natureza (chuvas, incêndios, excesso de umidade...).

Para exercer seus direitos de comprador é importante que antes de montar seu produto você leia com atenção as instruções de cada passo do manual de montagem que acompanha o móvel.







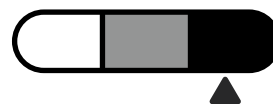
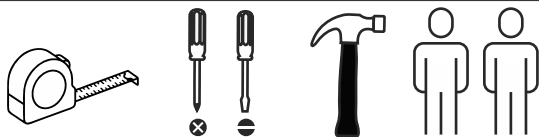

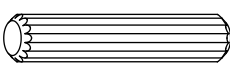
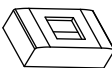
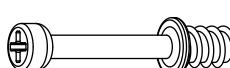
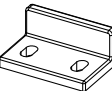
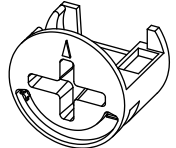
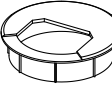
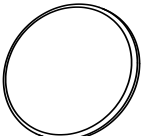
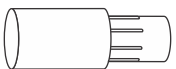

Caso o produto não esteja em conformidade, entre em contato com a loja onde efetuou a compra ou com o nosso Serviço de Atendimento ao Cliente através do fone (41) 3556 1500 ou do e-mail assistencia@artany.com.br, e faça sua reclamação, apontando os defeitos técnicos observados, que teremos o maior prazer em atendê-lo. Para agilizar o seu atendimento, tenha sempre em mãos o manual de montagem com os respectivos números das peças defeituosas conforme descritas no manual.

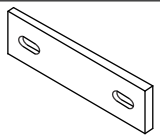
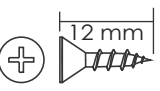
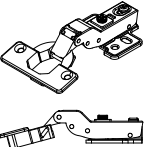
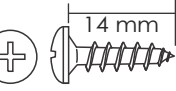
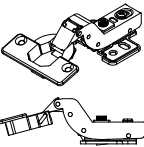
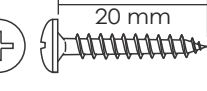
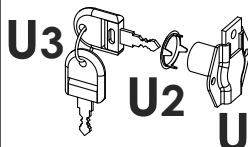
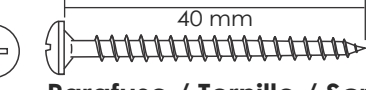
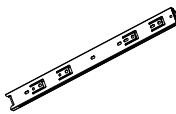
Ferramentas não fornecidas
Herramientas no provistas
Tools not provided

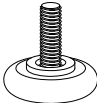
Dificuldade
Dificultad
Difficulty

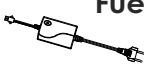
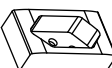

Lista de materiais / Lista de materiales / Hardware list

A	1:1 	Cavilha Tarugo Dowel Ø6x30mm	40	N		Conector RJ45 Conector RJ45 RJ45 connector	01
B	1:1 	Minifix Minifix Minifix Ø7x30mm	59	O		Batente Solapa Drawer Stop	03
C	1:1 	Tambor Tambor Minifix cam Ø15x12mm	63	P		Passa Fio Pasacable Cable Hole Cover	02
D	1:1 	Tapa furo Adesivo Adhesivo Hole Cover Ø18mm	51	Q		Pino Suporte Pasador de Apoyo Support pin	04
E	1:1 	Haste Dupla Minifix Minifix Doble Varilla / Double Rod Minifix 1:1 Ø7x60mm	02	R		Junção Unión Junction 50x13 mm	01
F	1:1 	Parafuso Tornillo Screw Ø3,5x12 mm CC	56	S		Dobradiça Curva Bisagra Semiacodada Half Overlay Cod. 105458	02
G	1:1 	Parafuso Tornillo Screw Ø4,0x14 mm CP	26	T		Dobradiça Super Curva Bisagra Acodada Inset Hinge Cod. 109529	02
H	1:1 	Parafuso Tornillo Screw Ø4,0x20 mm CP	24	U		Kit Fechadura Kit de Cerradura Lock Kit Cod. 102507	01
I	1:1 	Parafuso / Tornillo / Screw Ø3,5x40 mm CP	09	W		Corrediça Telescópica Corrediza Telescópica Telescopic Slide 400 mm	08
J		Bucha Sapata Buje Pata Foot Bushing	10	X		Barra Fechadura Barra de Bloqueo / Lock Bar 440 mm - Cod. 105472	01
K		Sapata Pata Foot	10	Y1		Fita LED Tira LED LED Strip 1850 mm	02
L	L1 	Caixa de Tomadas Caja de Enchufe Electrical Outlet	01	Y2		Cabo Multi-conector Cable Multiconector Multi-connector Cable	01
	L2 	Parafuso Tornillo Screw Ø3,0x10mm CC	02	Y3		Fonte de Alimentação Fuente de Alimentación Power Supply 100-240v	01
M		Tomada 10A 10A Salida 10A Outlet	02	Y4		Interruptor Interruptor Power Switch	01
				Y5		Grampo para Cabo Grapas para Cables Cable Clip	06

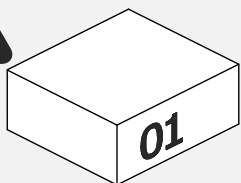

O número na borda da peça corresponde ao manual.
Para remover, use um pano com álcool em gel ou álcool 70%.

El número que aparece en el borde de la pieza corresponde al manual.
Para retirarlo, utilice un paño con alcohol en gel o alcohol al 70%.

The number on the edge of the piece corresponds to the assembly guide.
To remove it, use a cloth with alcohol gel or 70% alcohol.

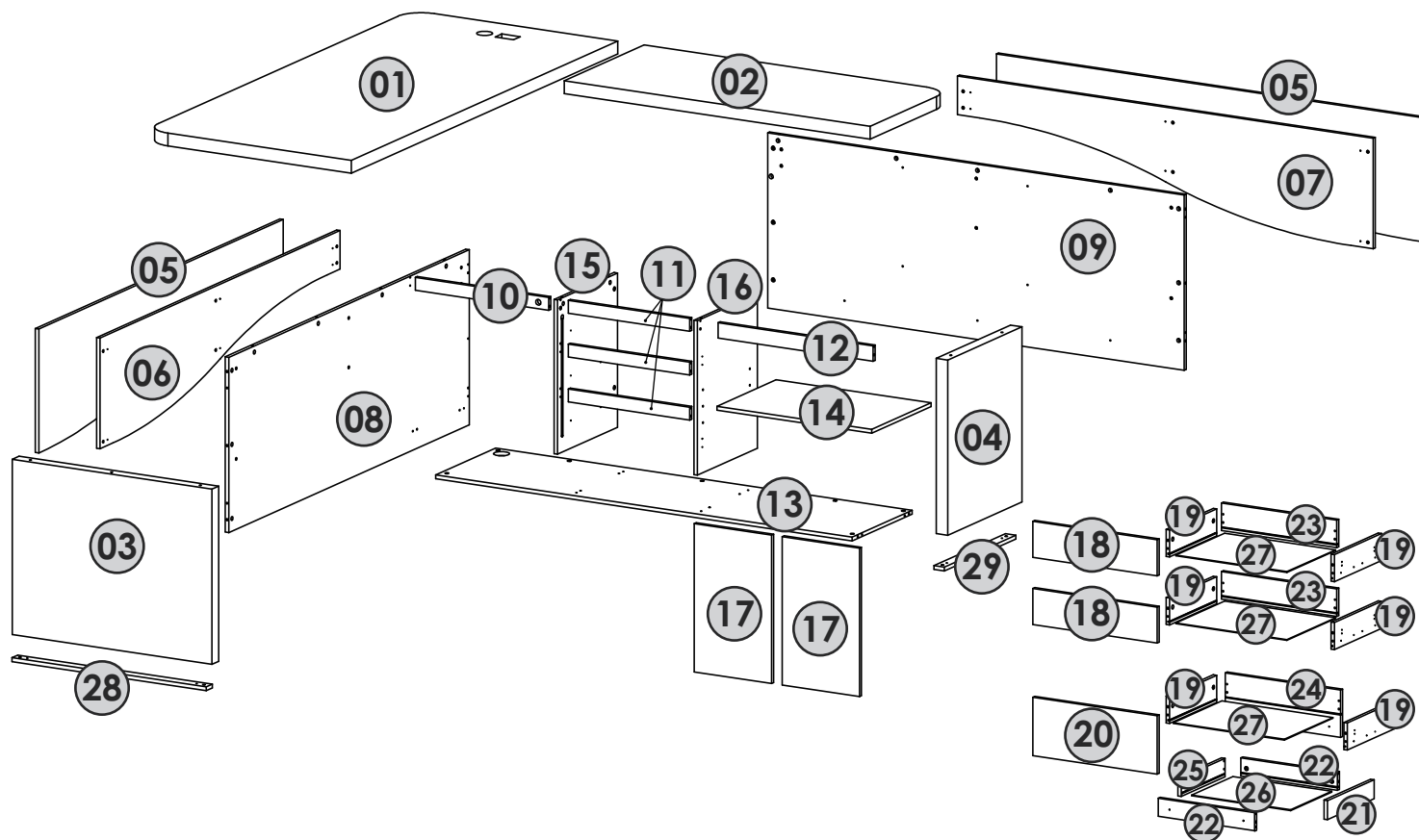

Item	Descrição Description Description			Dimensões Dimensiones Dimensions mm			Qty Ctd Qty	Volume Volumen Volume
	Português	Español	English	Comprimento Largo Length	Largura Ancho Width	Espessura Grosor Thickness		
	01	Tampo	Tapa	Top	2000	895		
02	Tampo Menor	Tapa Menor	Small Top	1325	598	50	1	3 / 4
03	Lateral	Lateral	Side	666	865	50	1	3 / 4
04	Lateral Menor	Lateral Menor	Small Side	666	558	50	1	3 / 4
05	Painel	Panel	Panel	1835	482	15	2	2 / 4
06	Travessa LED Esquerda	Travesaño LED Izquierdo	Left LED Crossbar	1802	430	15	1	2 / 4
07	Travessa LED Direita	Travesaño LED Derecho	Right LED Crossbar	1802	430	15	1	2 / 4
08	Travessa A	Travesaño A	Crossbar A	1805	681	15	1	2 / 4
09	Travessa B	Travesaño B	Crossbar B	1805	681	15	1	2 / 4
10	Travessa C	Travesaño C	Crossbar C	578	50	15	1	2 / 4
11	Travessa D	Travesaño D	Crossbar D	526	50	15	3	2 / 4
12	Travessa E	Travesaño E	Crossbar E	671	60	15	1	2 / 4
13	Base	Base	Base	1805	450	15	1	1 / 4
14	Prateleira	Estante	Shelf	671	445	15	1	1 / 4
15	Lateral A	Lateral A	Side A	600	450	15	1	1 / 4
16	Lateral B	Lateral B	Side B	600	450	15	1	1 / 4
17	Porta	Puerta	Door	577	335	15	2	1 / 4
18	Frente Gaveta	Frente de Cajón	Frente de Cajón	538	140	15	2	1 / 4
19	Lateral Gaveta	Lateral de Cajón	Drawer Side	354	105	15	6	1 / 4
20	Frente Gaveta Maior	Frente de Cajón Mayor	Large Drawer Front	538	227	15	1	1 / 4
21	Frente Gaveta Menor	Frente de Cajón Menor	Small Drawer Front	350	74	15	1	1 / 4
22	Lateral Gaveta Menor	Lateral de Cajón Menor	Small Drawer Side	418	70	15	2	1 / 4
23	Traseira Gaveta	Trasera de Cajón	Drawer Back	500	107	15	2	1 / 4
24	Traseira Gaveta Maior	Trasera de Cajón Mayor	Large Drawer Back	500	184	15	1	1 / 4
25	Traseira Gaveta Menor	Trasera de Cajón Menor	Small Drawer Back	328	72	15	1	1 / 4
26	Fundo Gaveta Menor	Fondo de Cajón Menor	Small Drawer Bottom	309	429	3	1	1 / 4
27	Fundo Gaveta	Fondo de Cajón	Drawer Bottom	365	481	3	3	1 / 4
28	Travessa F	Travesaño F	Crossbar F	845	45	15	1	3 / 4
29	Travessa G	Travesaño G	Crossbar G	538	45	15	1	3 / 4

01

.1

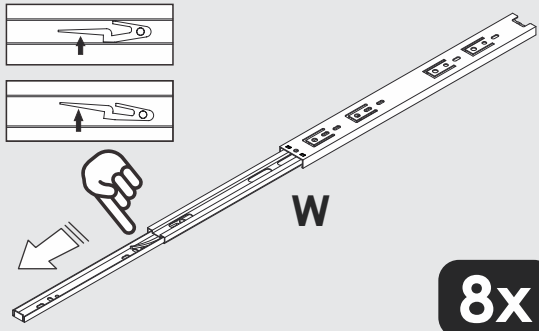

.2

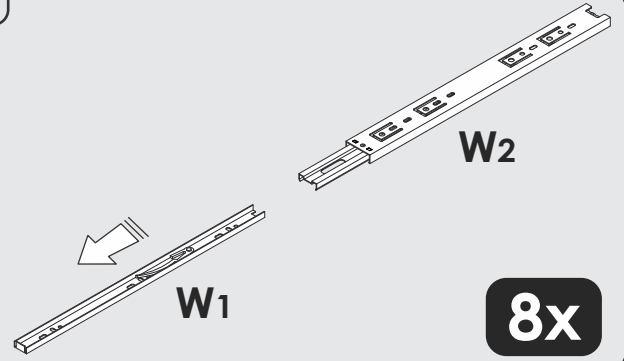

02

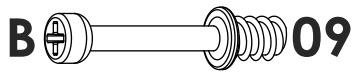
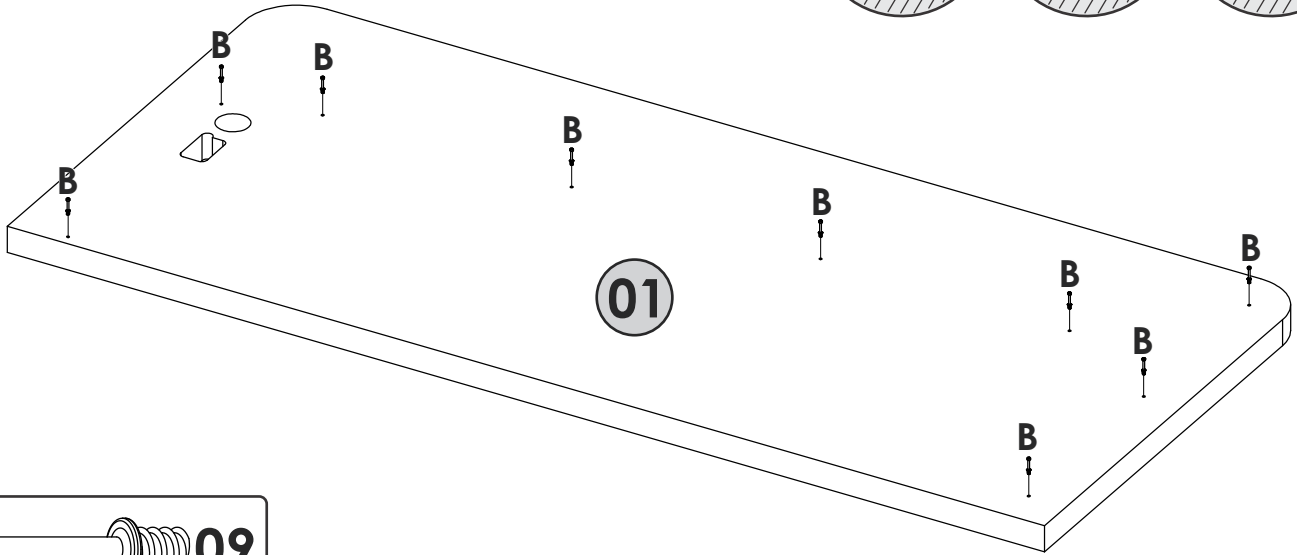
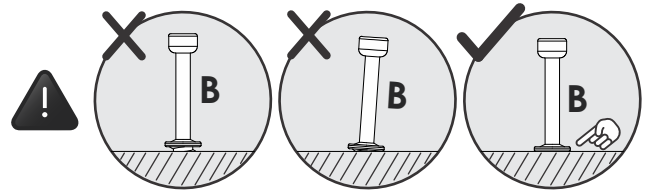

03

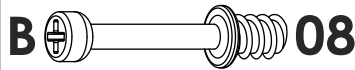
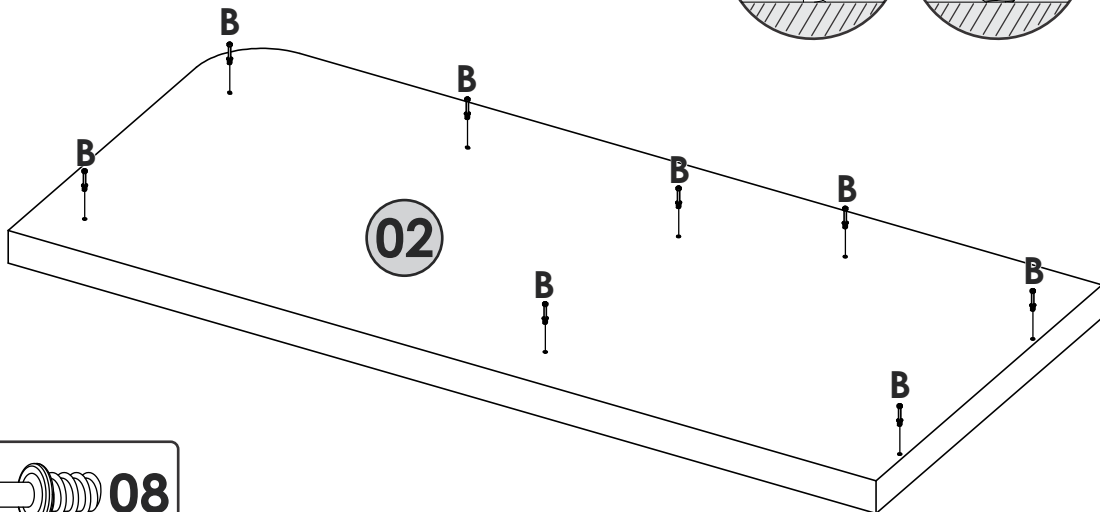
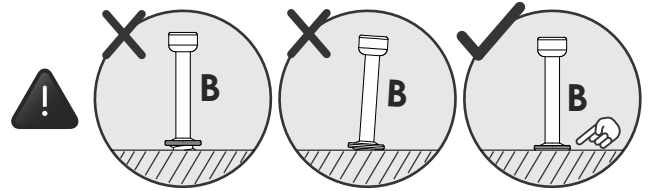

04

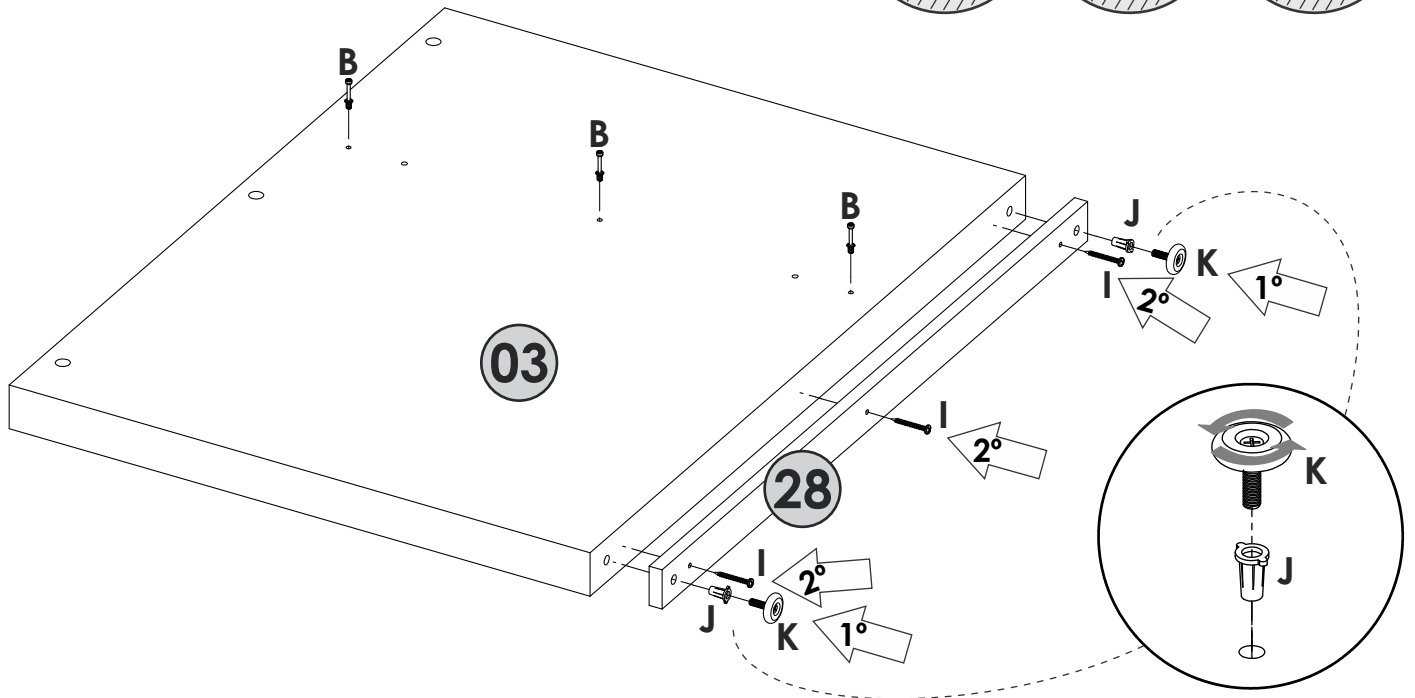
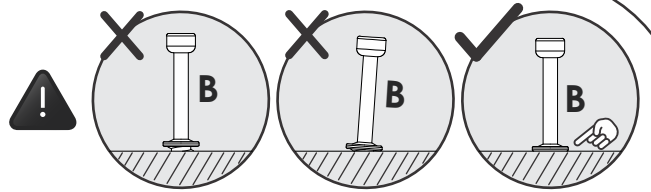

05

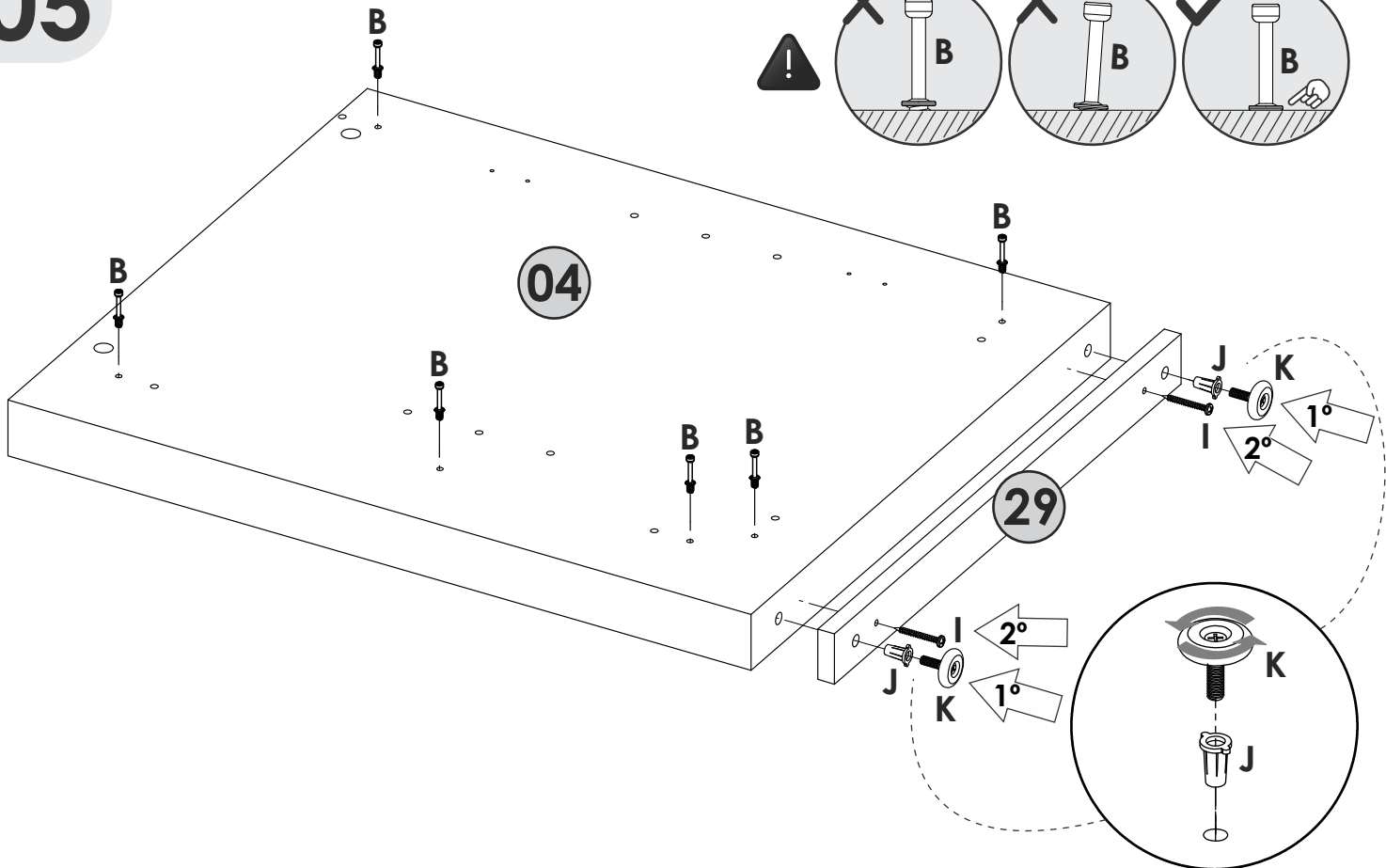
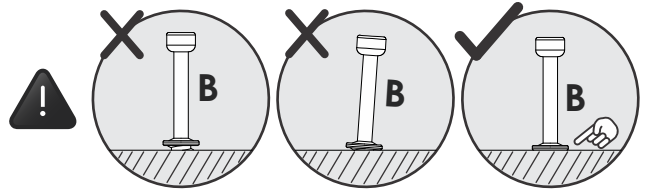

06

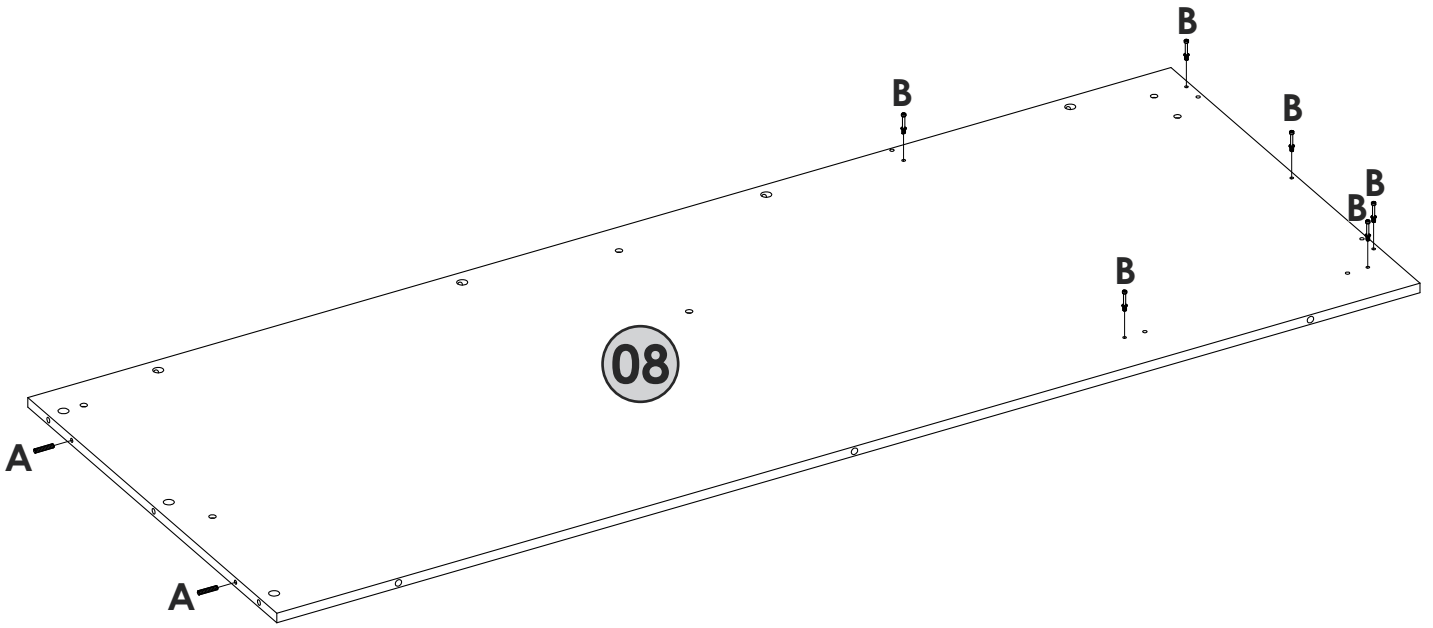
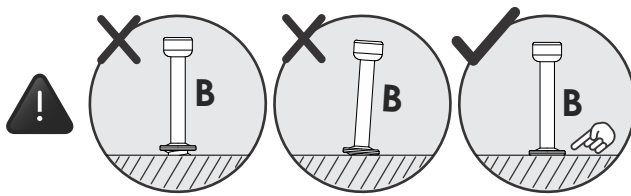

07

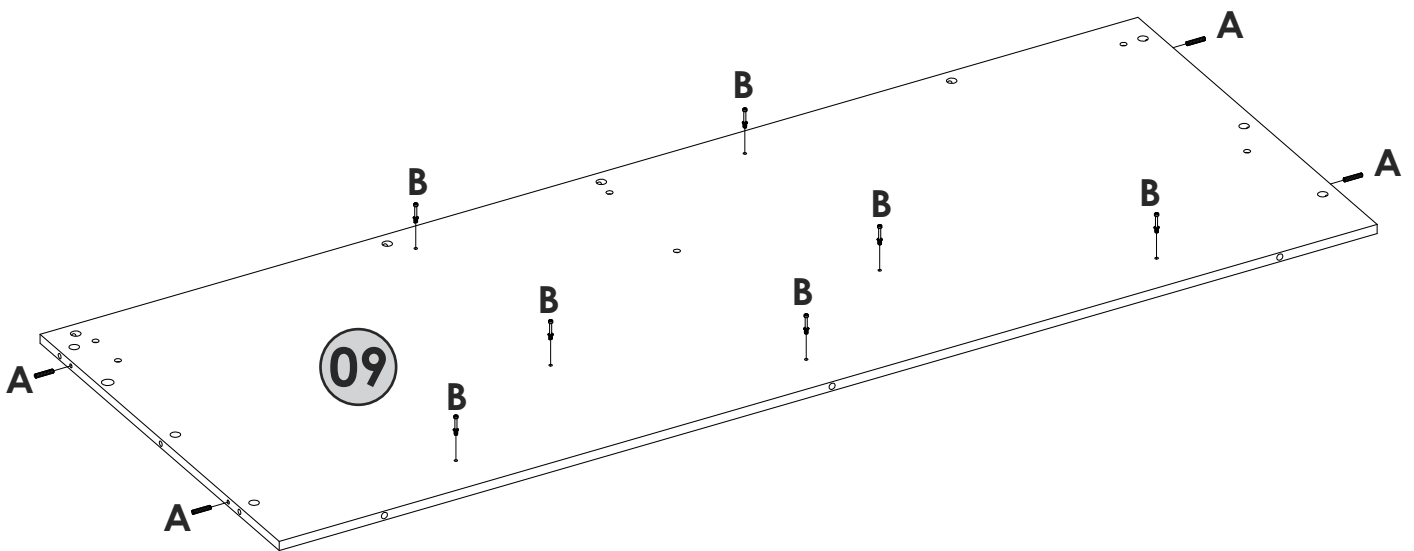
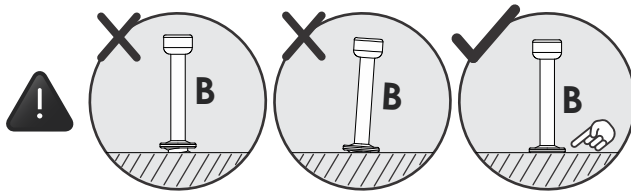

08

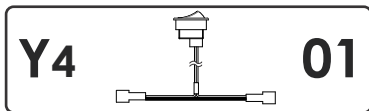
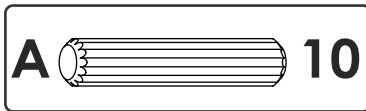
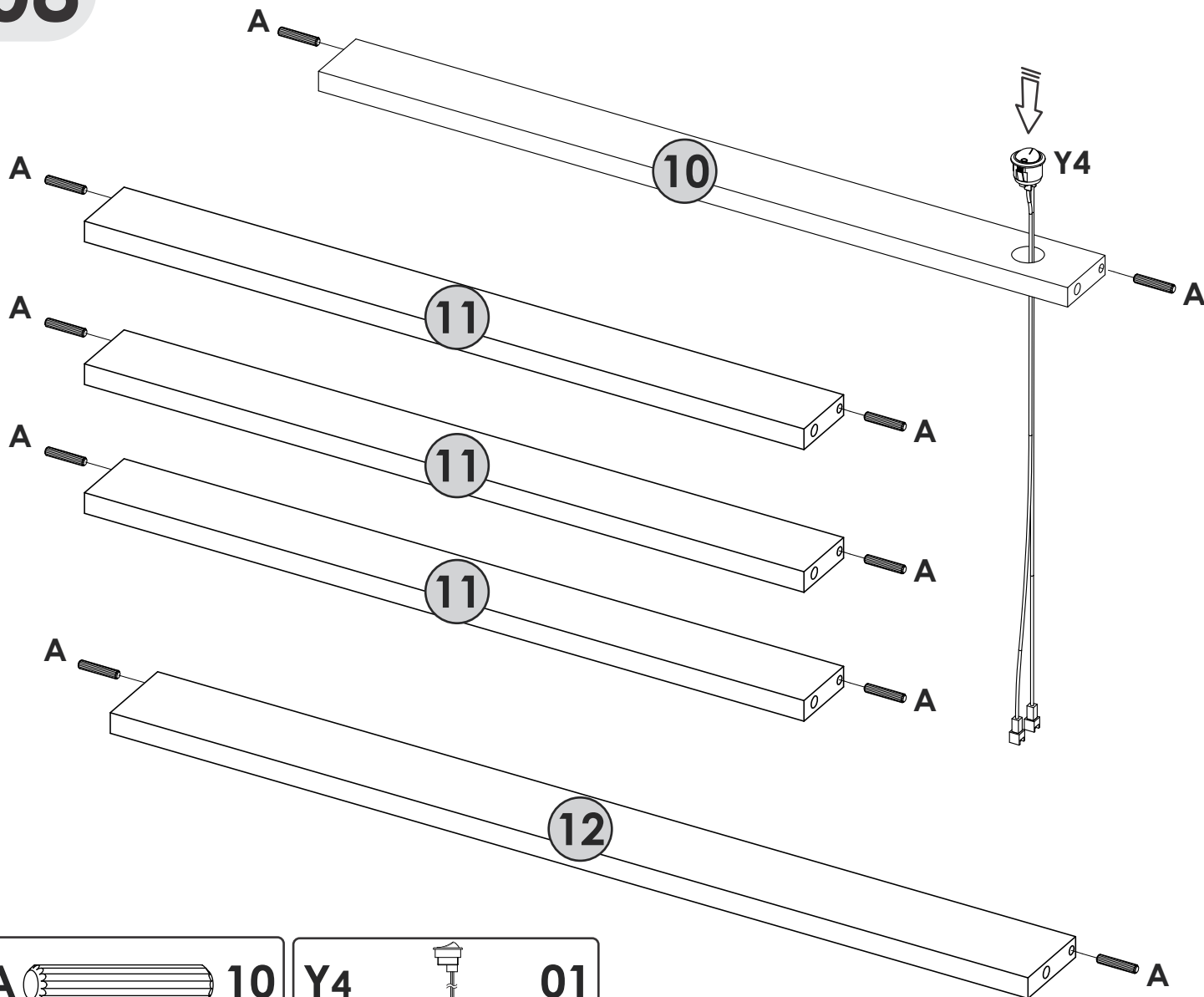

09

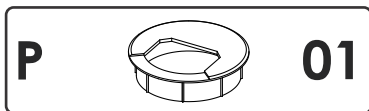
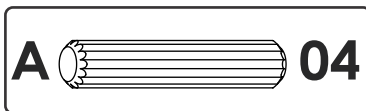
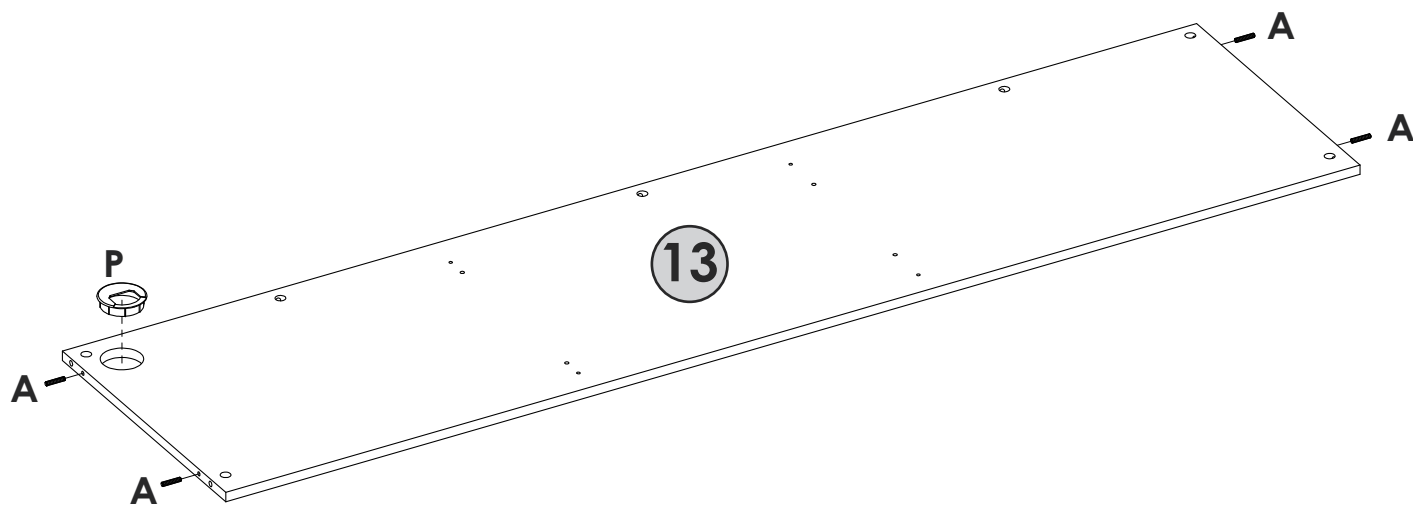

10

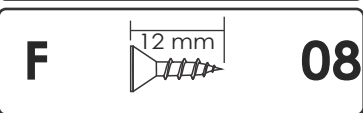
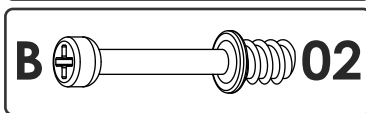
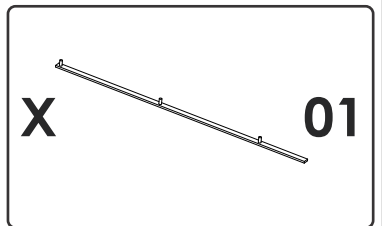
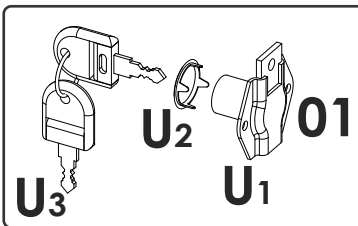
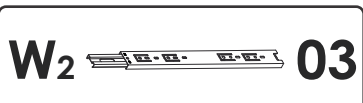
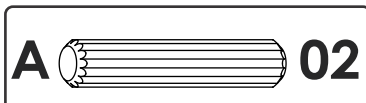
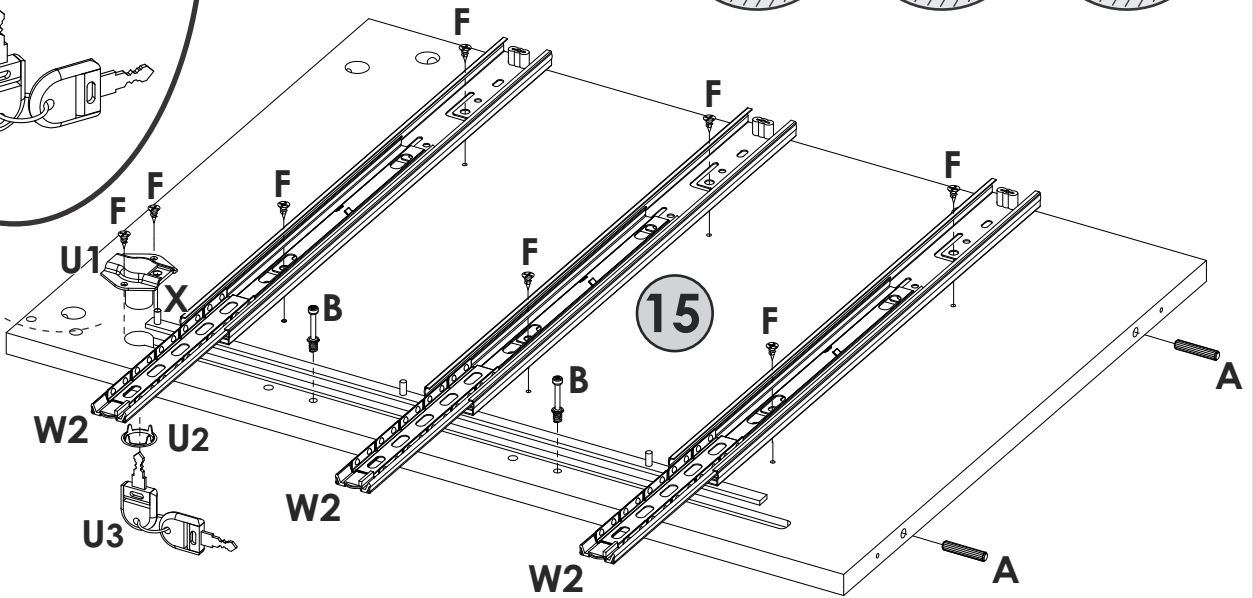
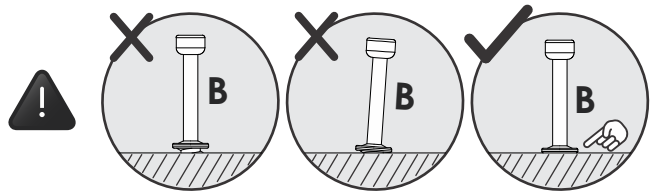
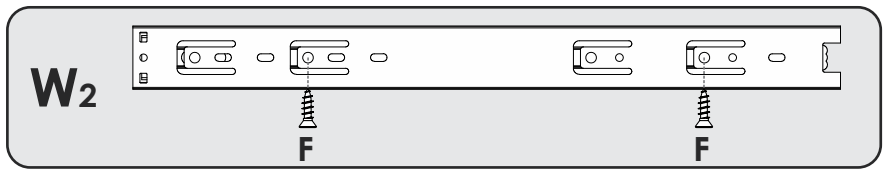
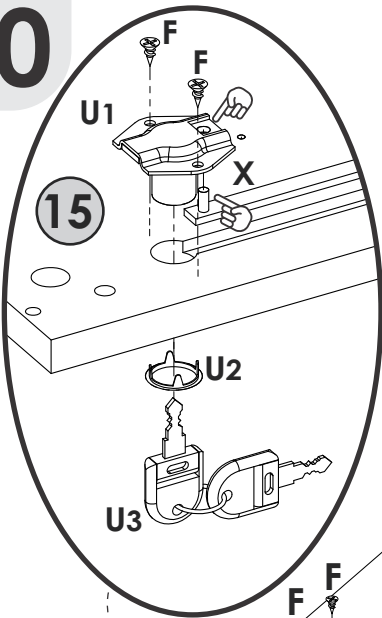

11

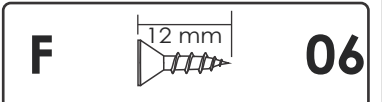
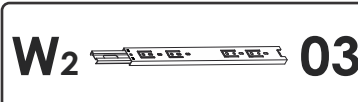
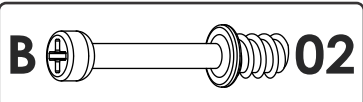
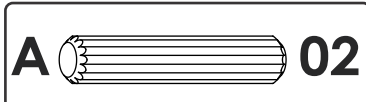
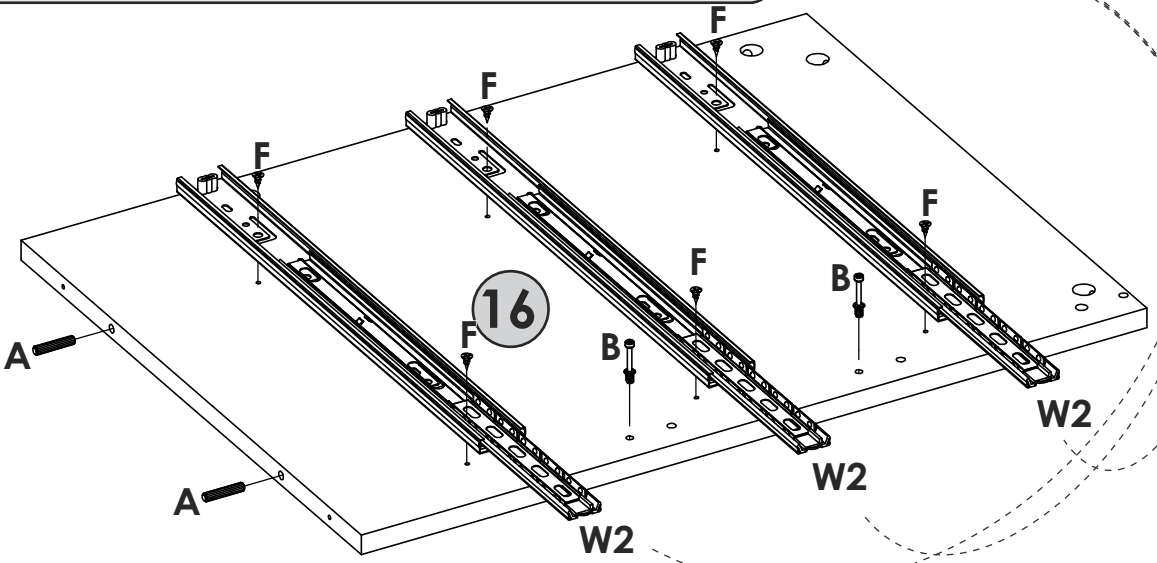
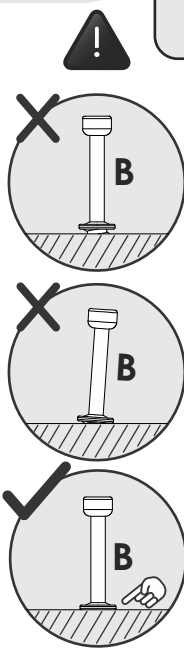
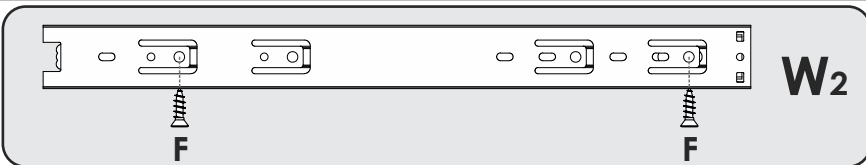

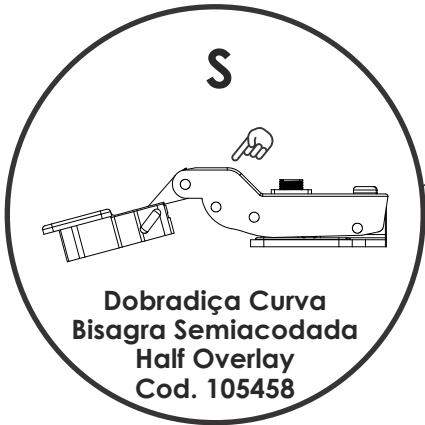
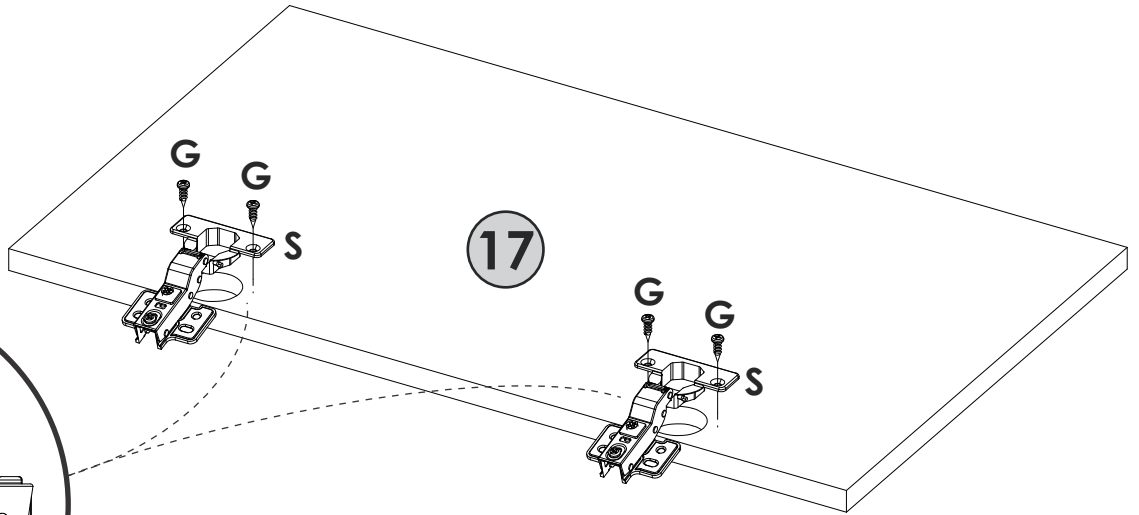
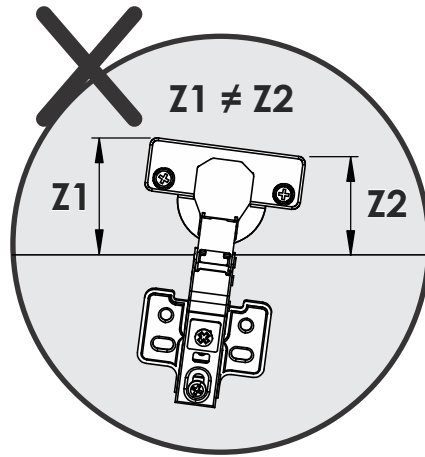
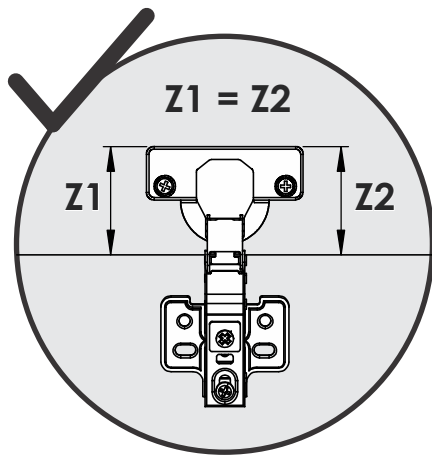

Dobradiça Curva
Bisagra Semiacodada
Half Overlay
Cod. 105458

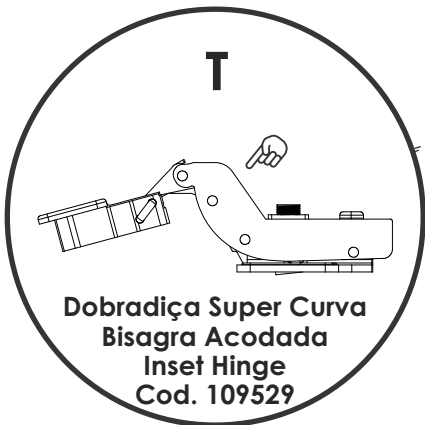
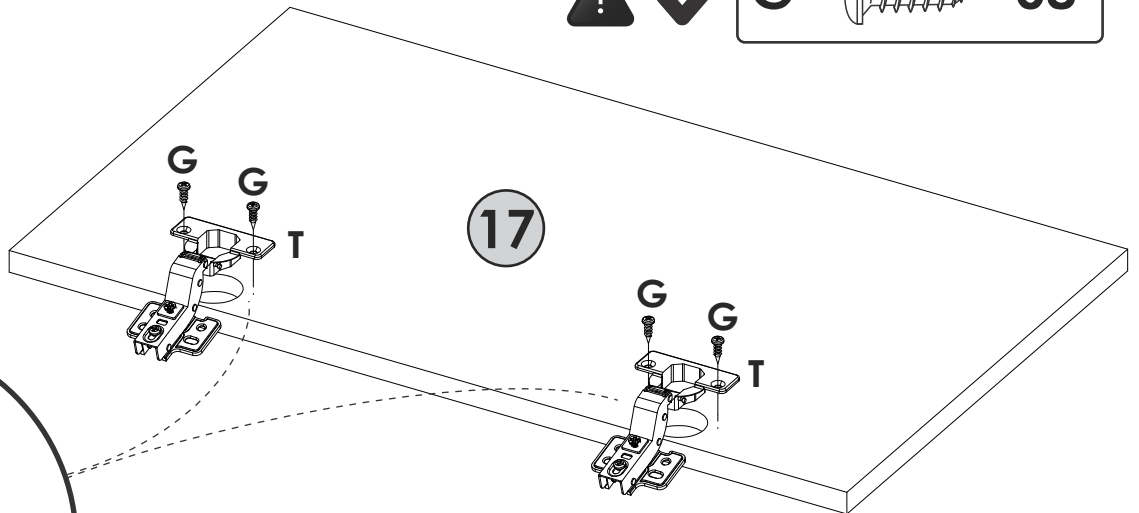
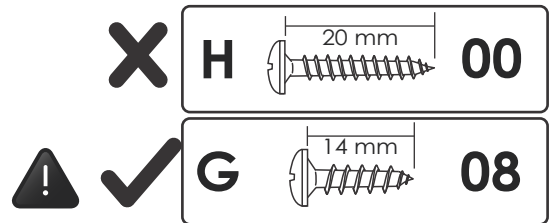

Dobradiça Super Curva
Bisagra Acodada
Inset Hinge
Cod. 109529

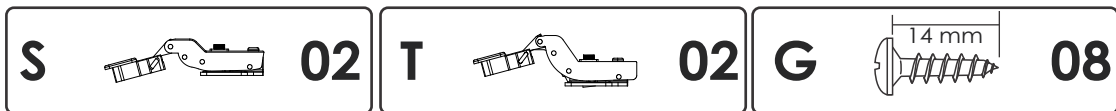

13

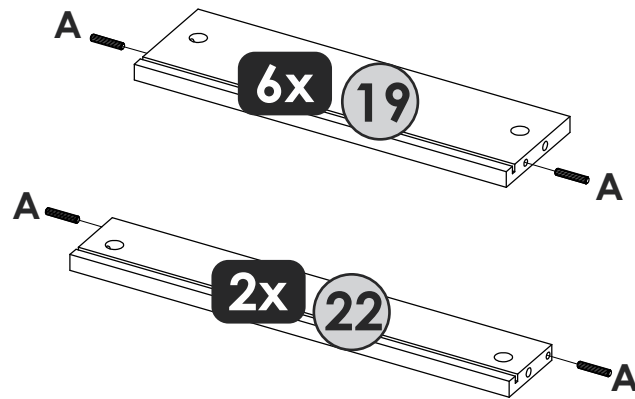
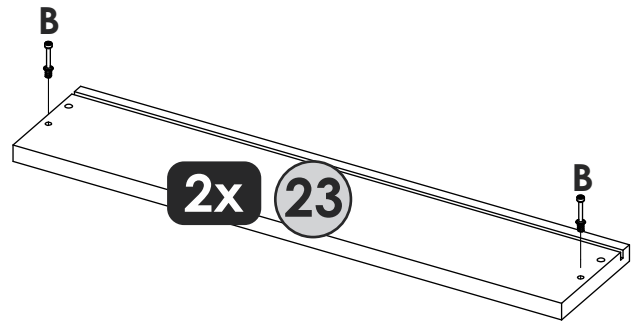
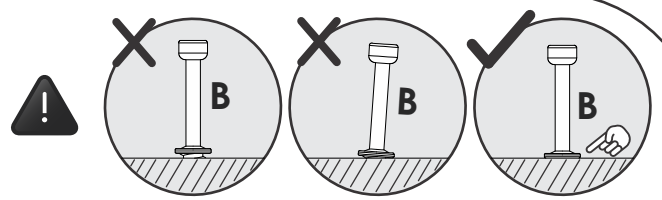
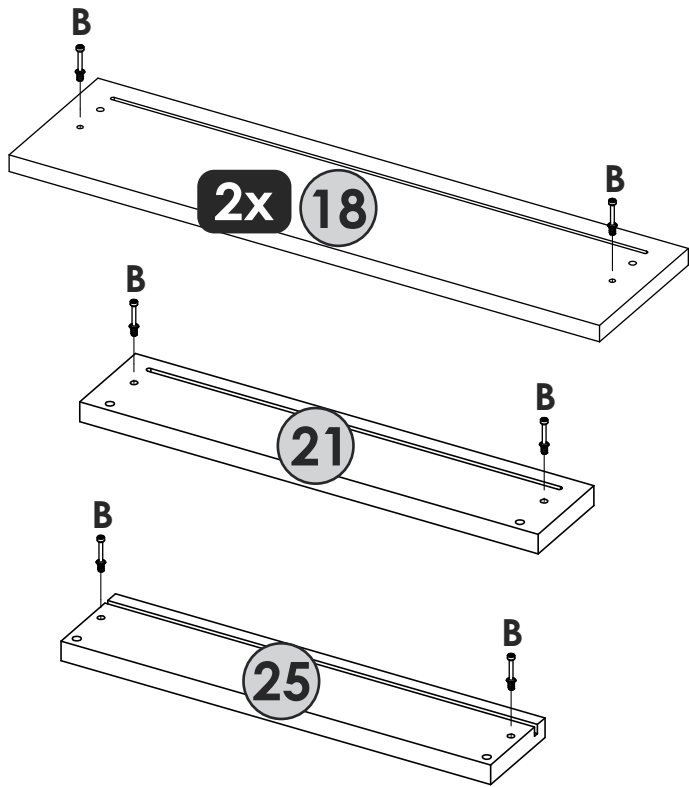

14

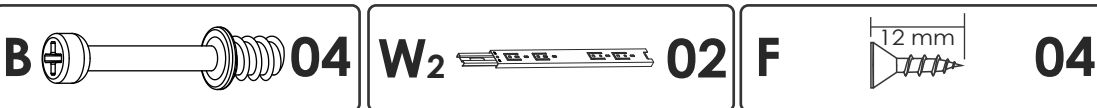
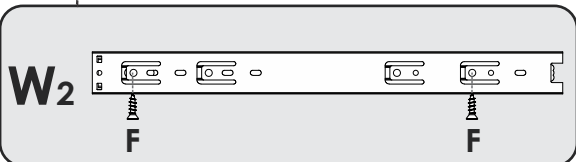
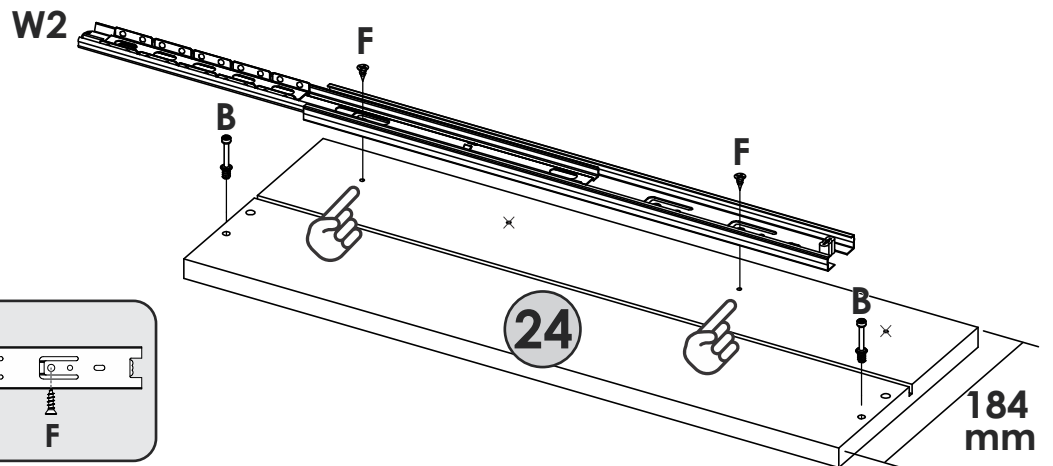
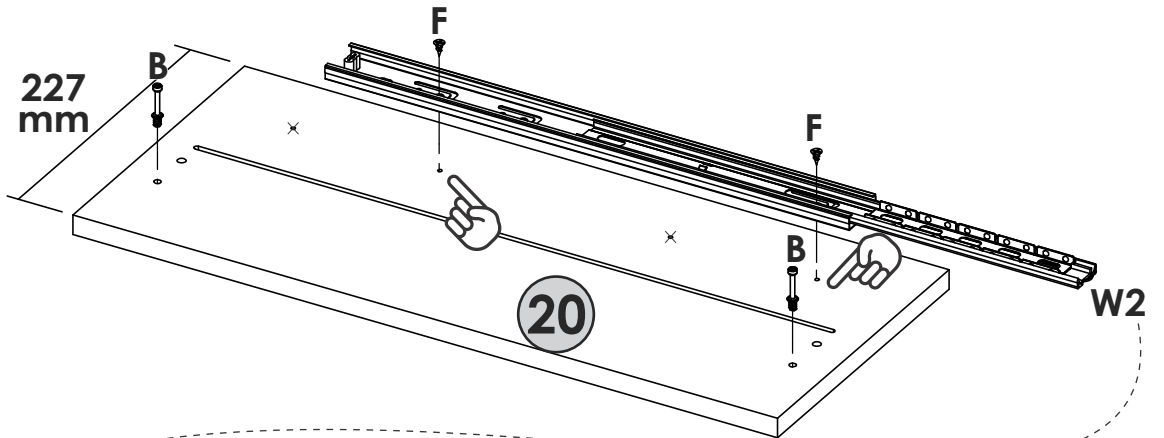

15

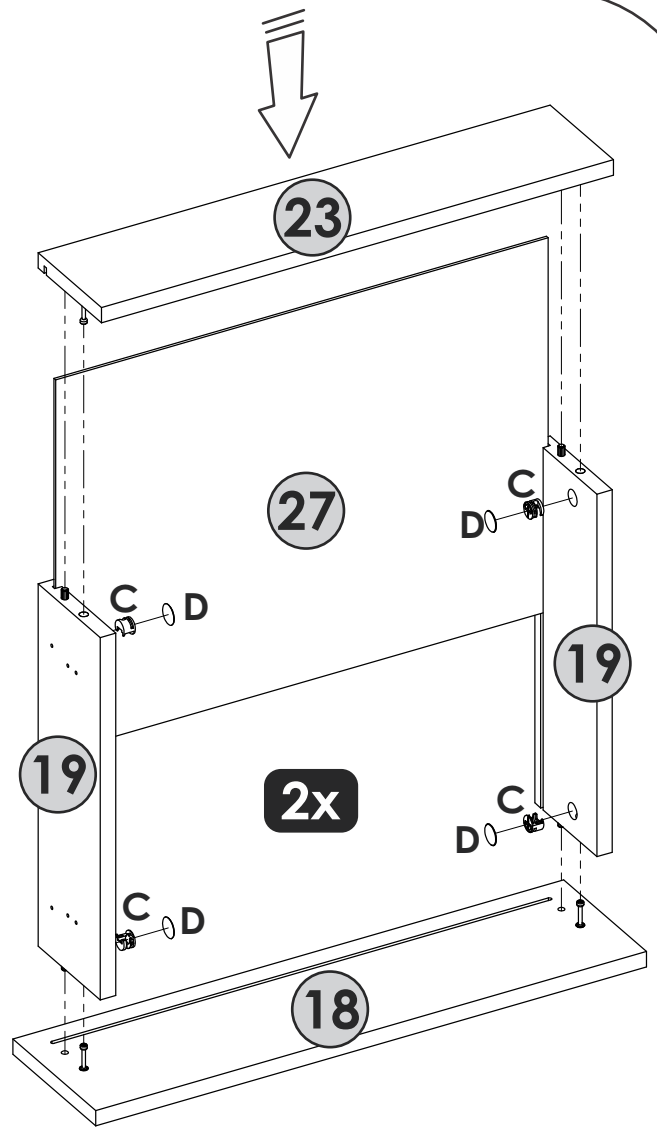
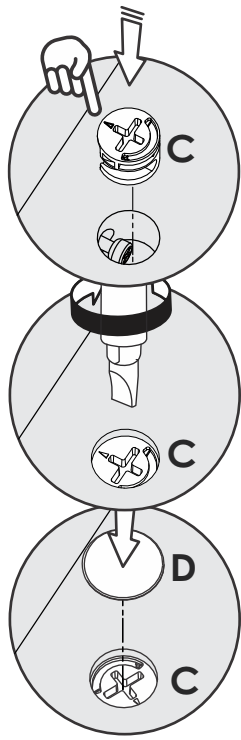

C  **08** **D**  **08**

16

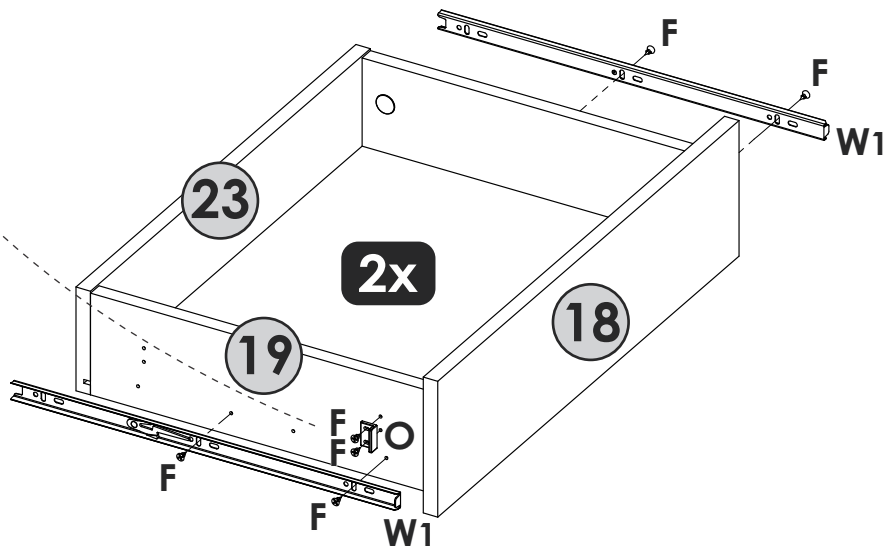
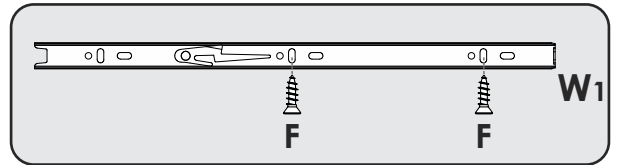
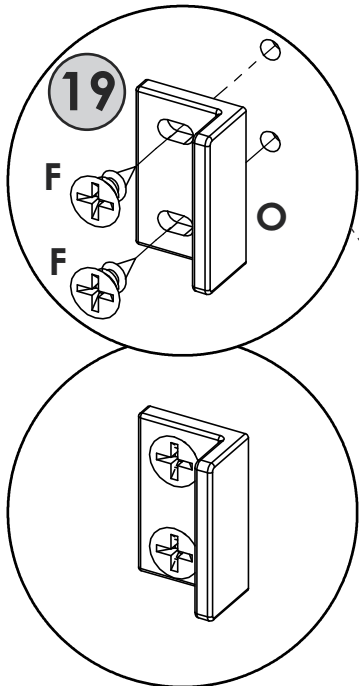

F  **12** **W1**  **04** **O**  **02**

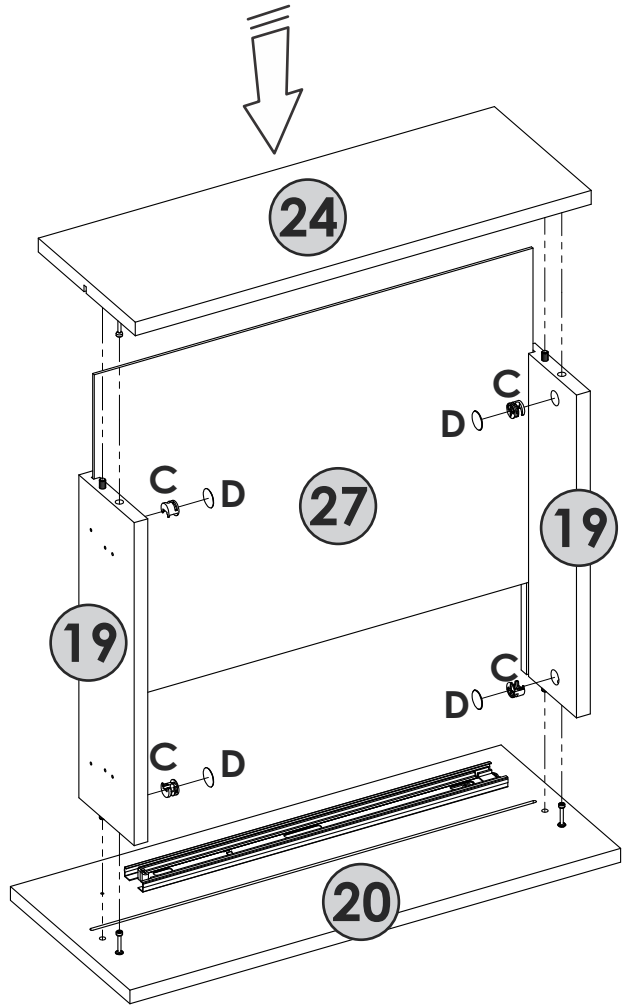
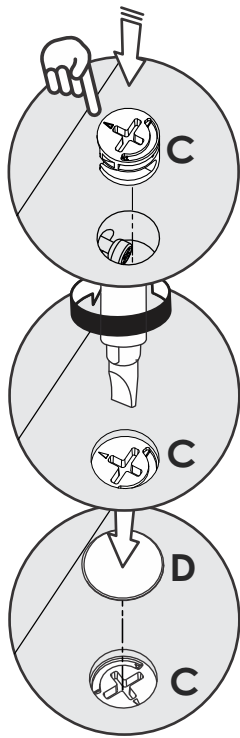

C



04

D



04

18

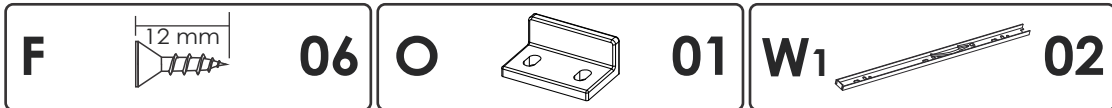
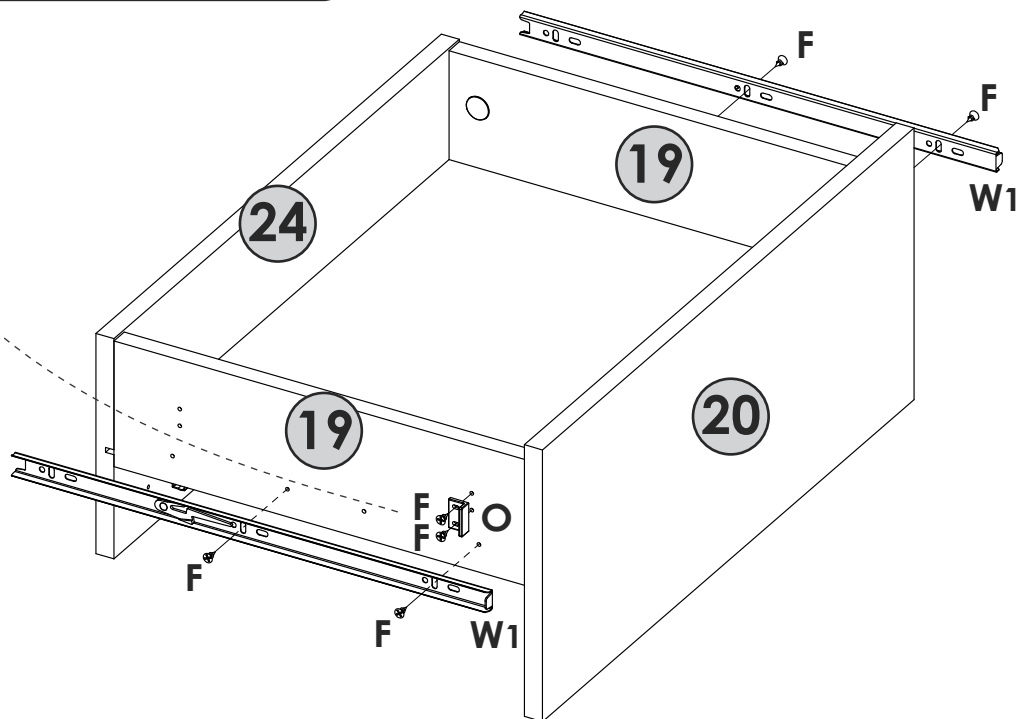
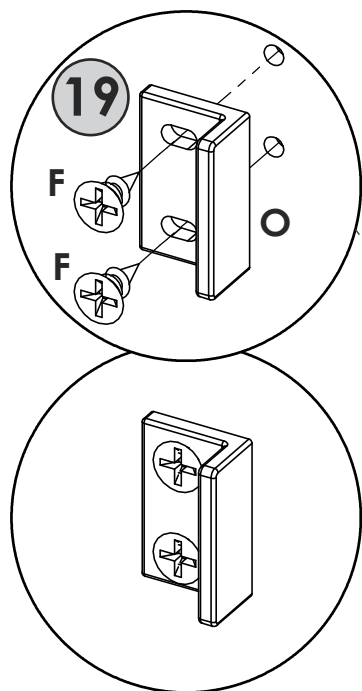
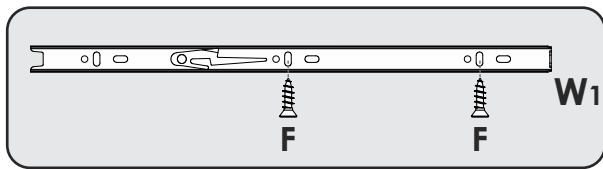

19

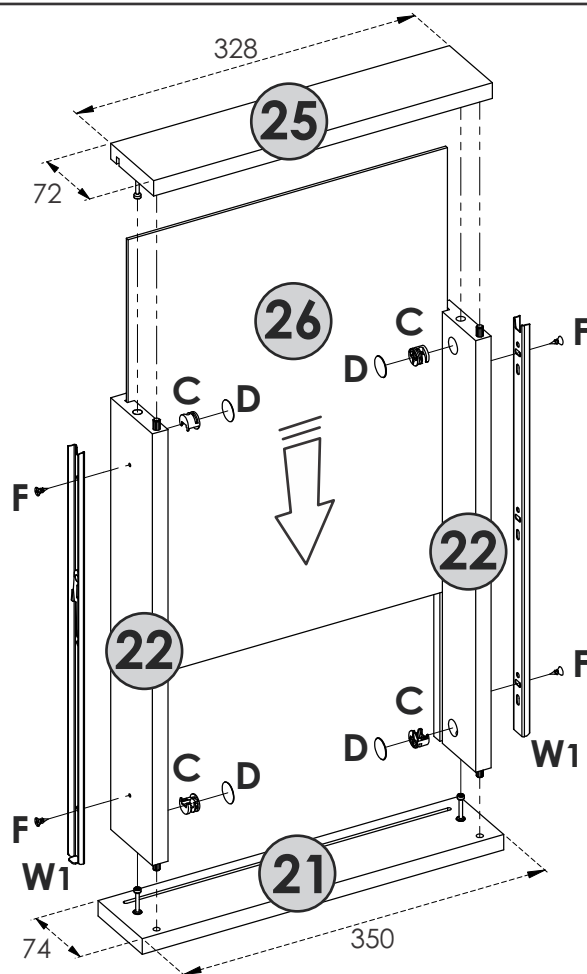
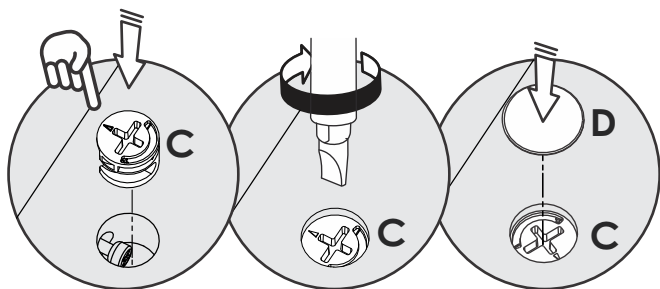
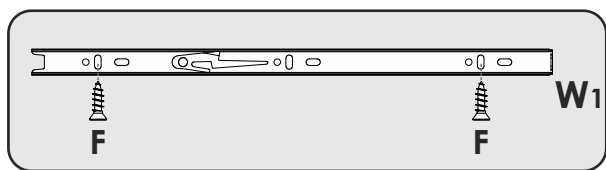

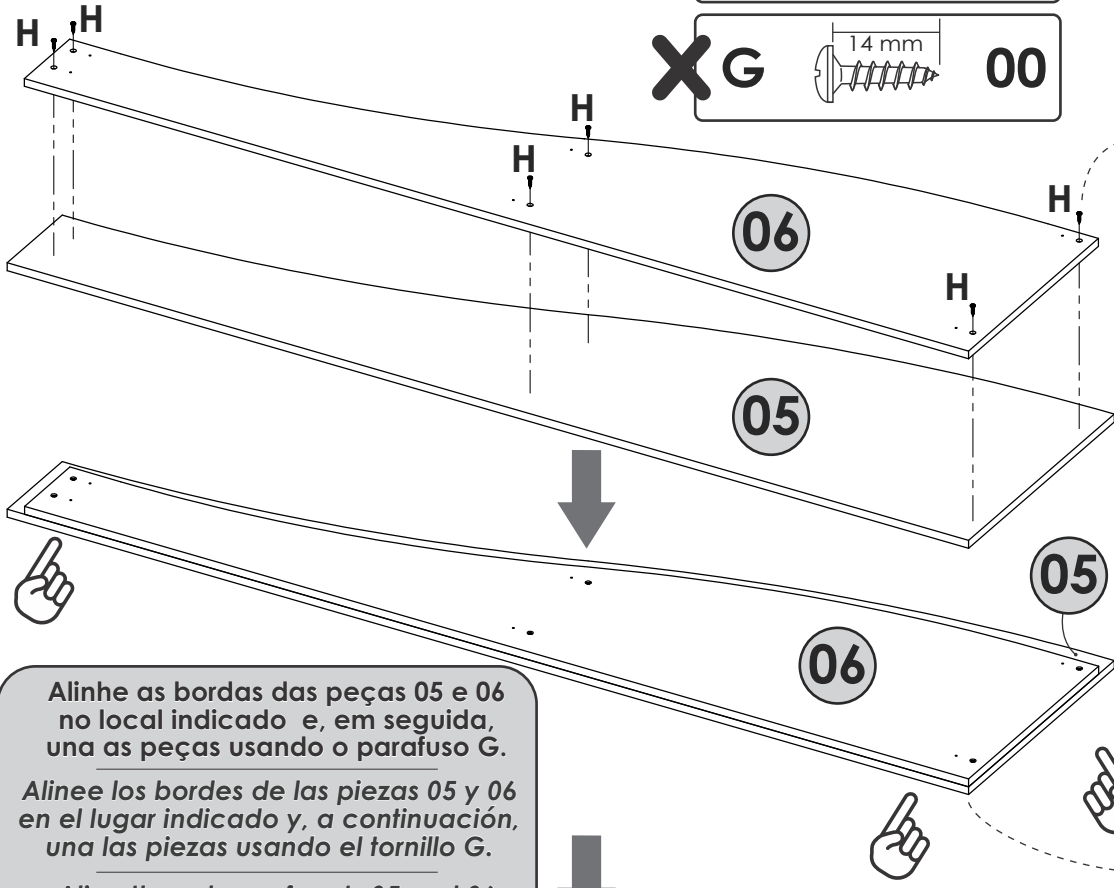
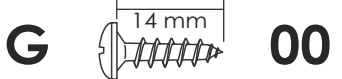
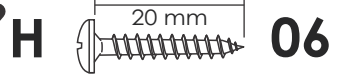

Alinhe as bordas das peças 05 e 06 no local indicado e, em seguida, una as peças usando o parafuso G.

Alinee los bordes de las piezas 05 y 06 en el lugar indicado y, a continuación, una las piezas usando el tornillo G.

Align the edges of parts 05 and 06 at the indicated location, and then join the parts using screw G.

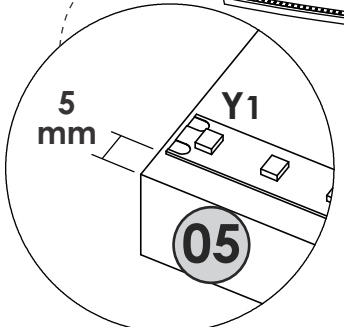
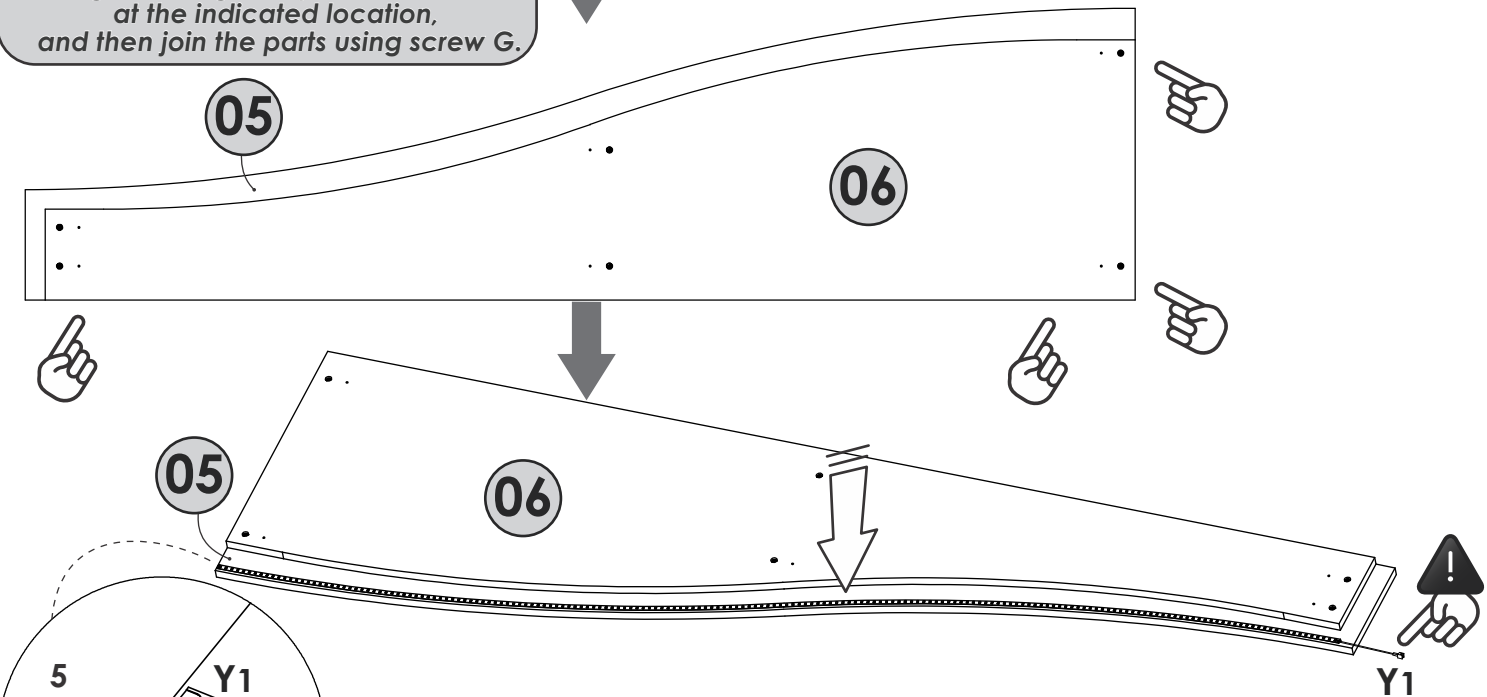

Limpe a superfície. Em seguida, cole a fita de LED (Y1) firmemente na Peça 05. O conector da fita LED deve ficar voltado para o lado menor.

Limpie la superficie. A continuación, pegue la tira de LED (Y1) firmemente en la Pieza 05. El conector de la tira de LED debe ficar orientado hacia el lado más corto.

Clean the surface. Then, firmly attach the LED strip (Y1) to Part 05. The LED strip connector should face the shorter side.

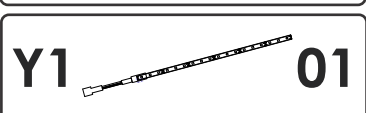
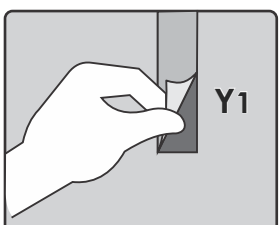
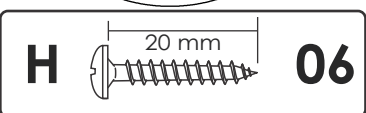

21

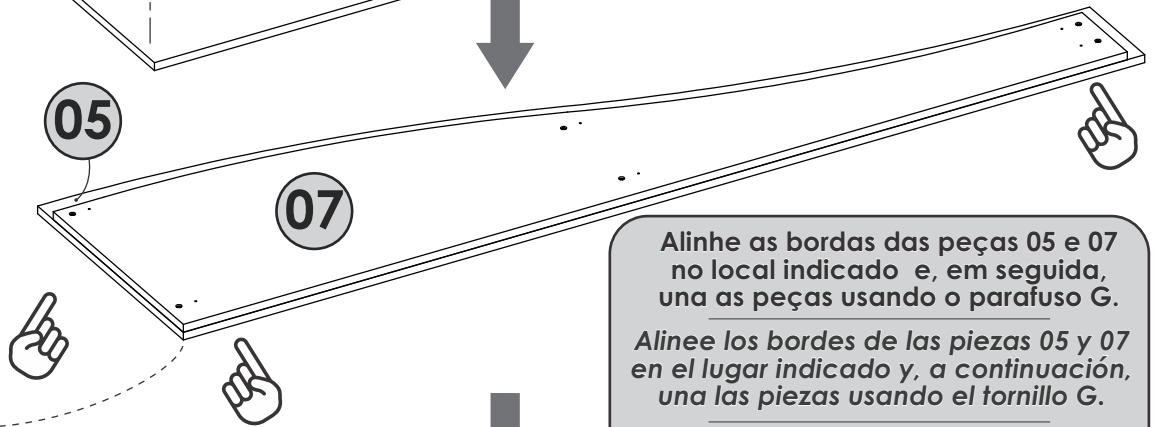
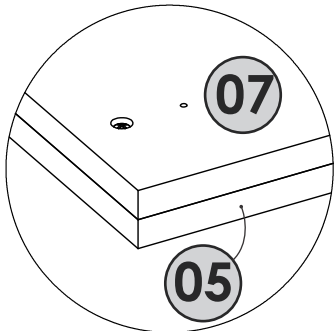
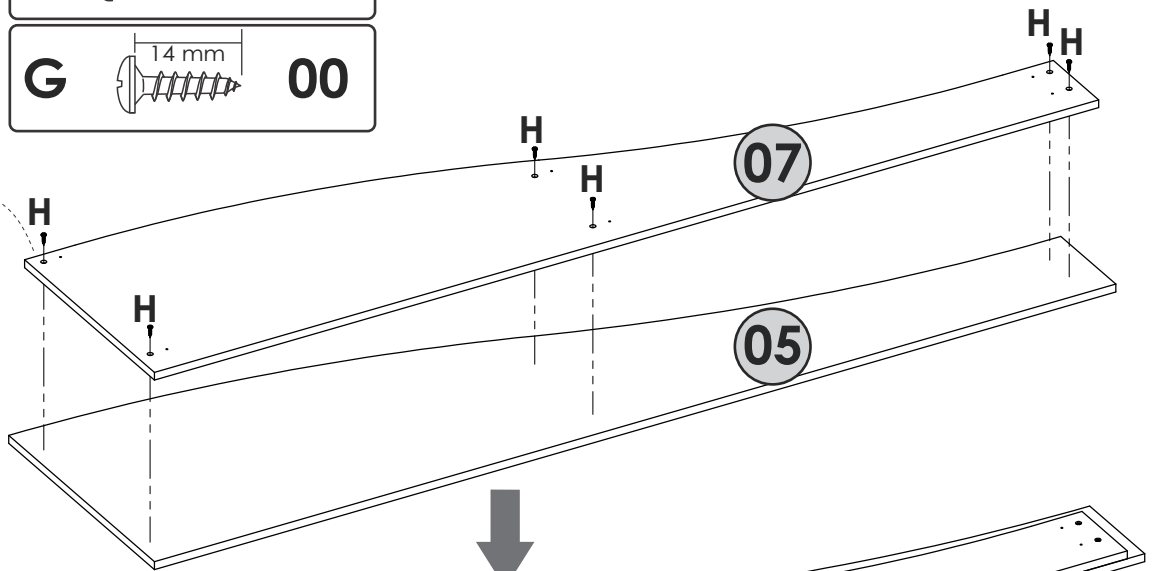
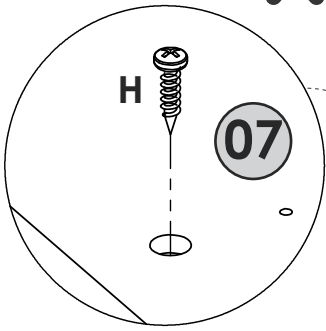
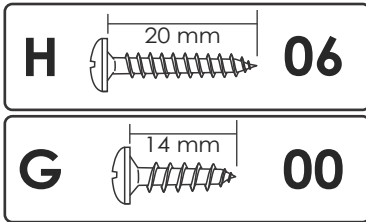

Alinhe as bordas das peças 05 e 07 no local indicado e, em seguida, una as peças usando o parafuso G.

Alinee los bordes de las piezas 05 y 07 en el lugar indicado y, a continuación, una las piezas usando el tornillo G.

Align the edges of parts 05 and 07 at the indicated location, and then join the parts using screw G.

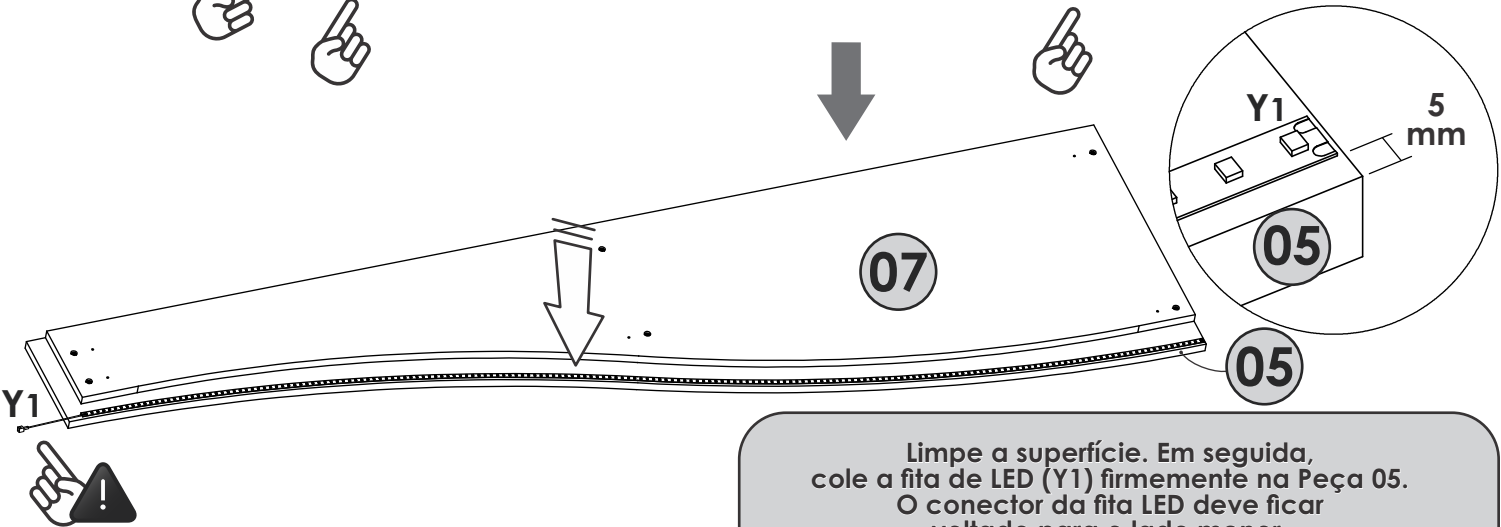
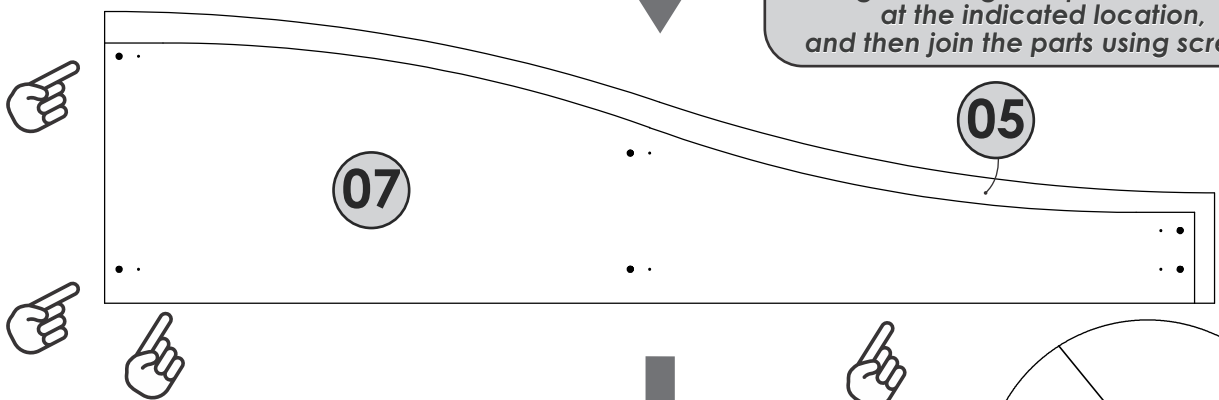

Limpe a superfície. Em seguida, cole a fita de LED (Y1) firmemente na Peça 05. O conector da fita LED deve ficar voltado para o lado menor.

Limpie la superficie. A continuación, pegue la tira de LED (Y1) firmemente en la Pieza 05. El conector de la tira de LED debe ficar orientado hacia el lado más corto.

Clean the surface. Then, firmly attach the LED strip (Y1) to Part 05. The LED strip connector should face the shorter side.

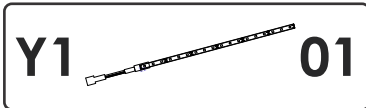
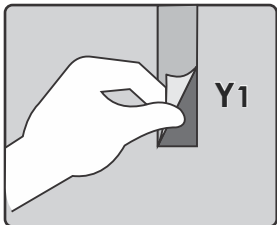
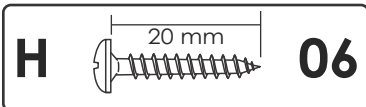

22 ✓

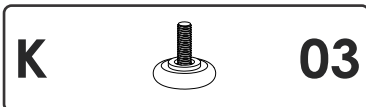
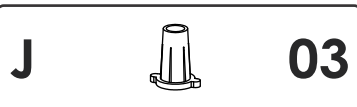
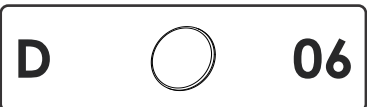
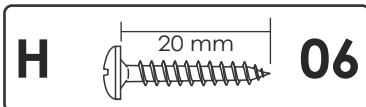
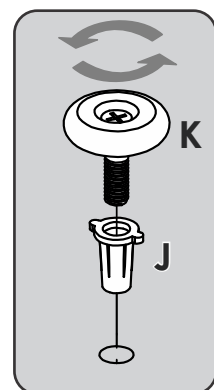
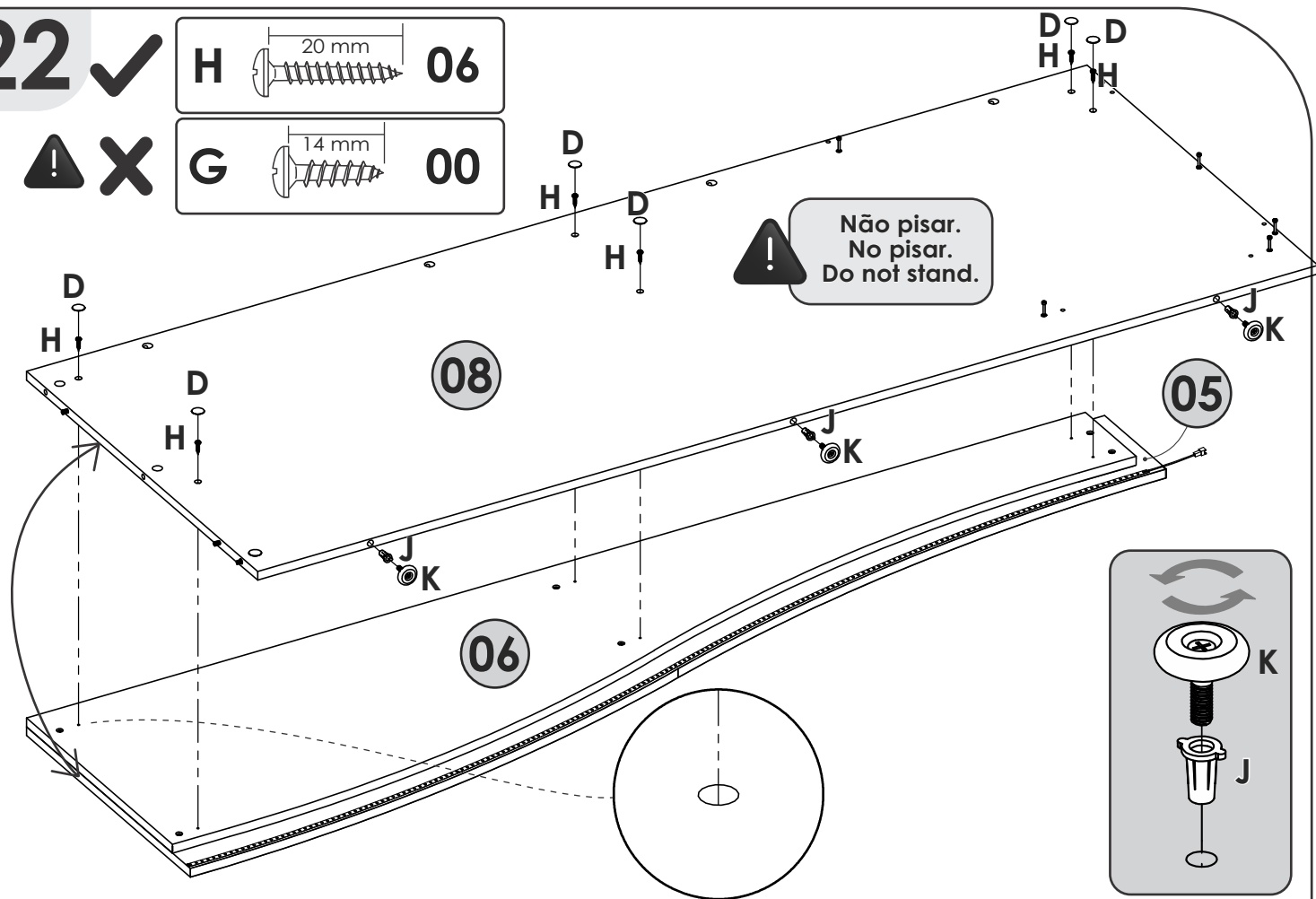
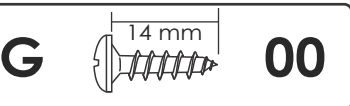
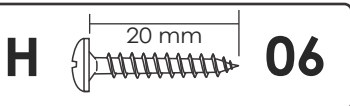

23



! Não pisar.
No pisar.
Do not stand.

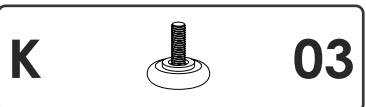
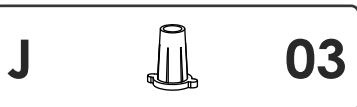
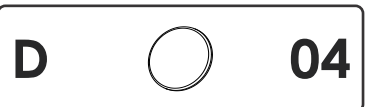
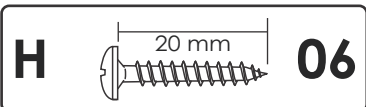
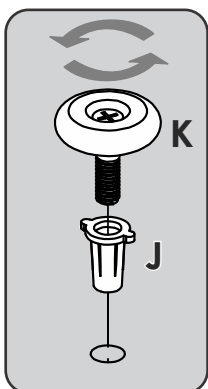
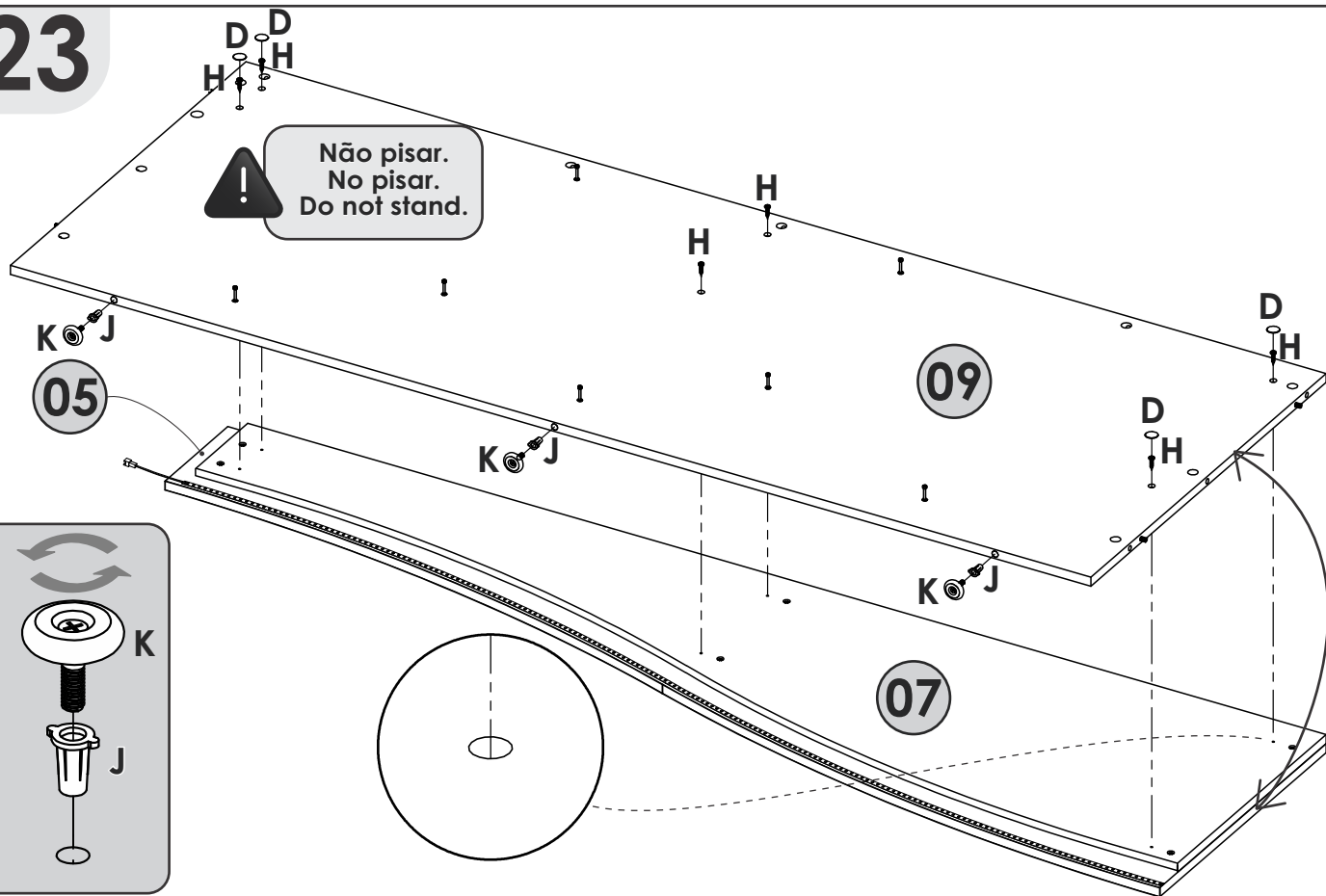

24

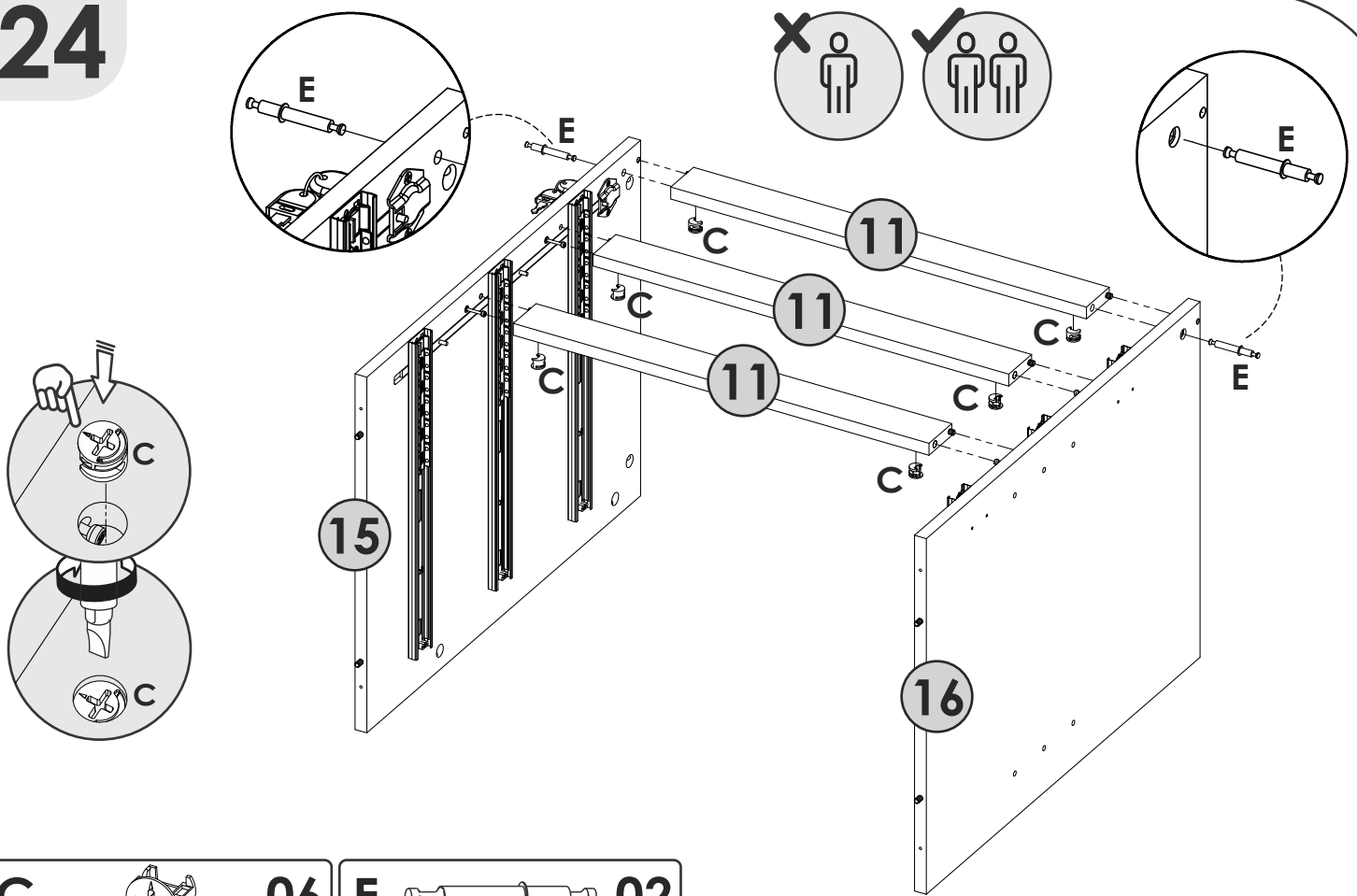

25

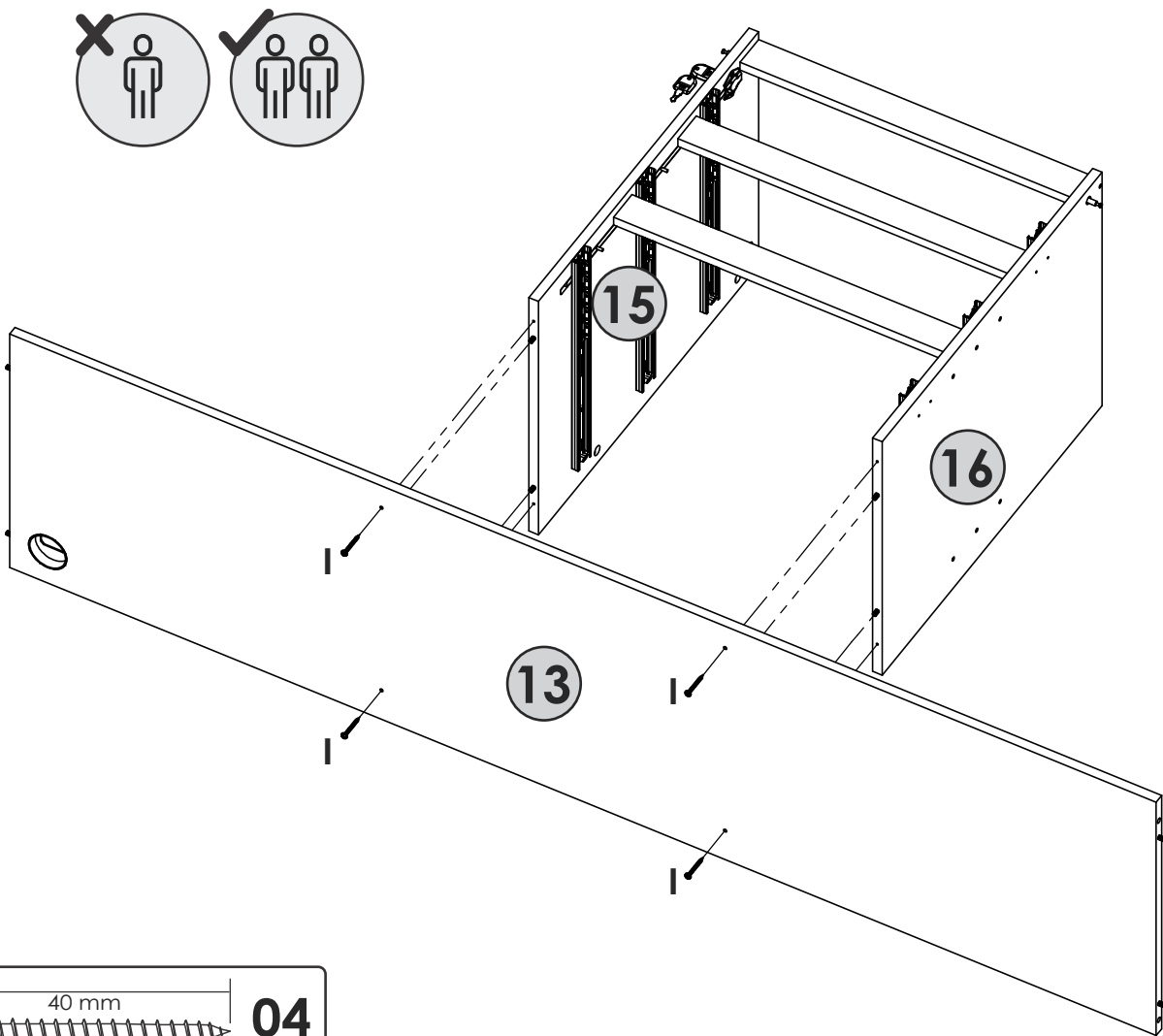

I 40 mm 04

26

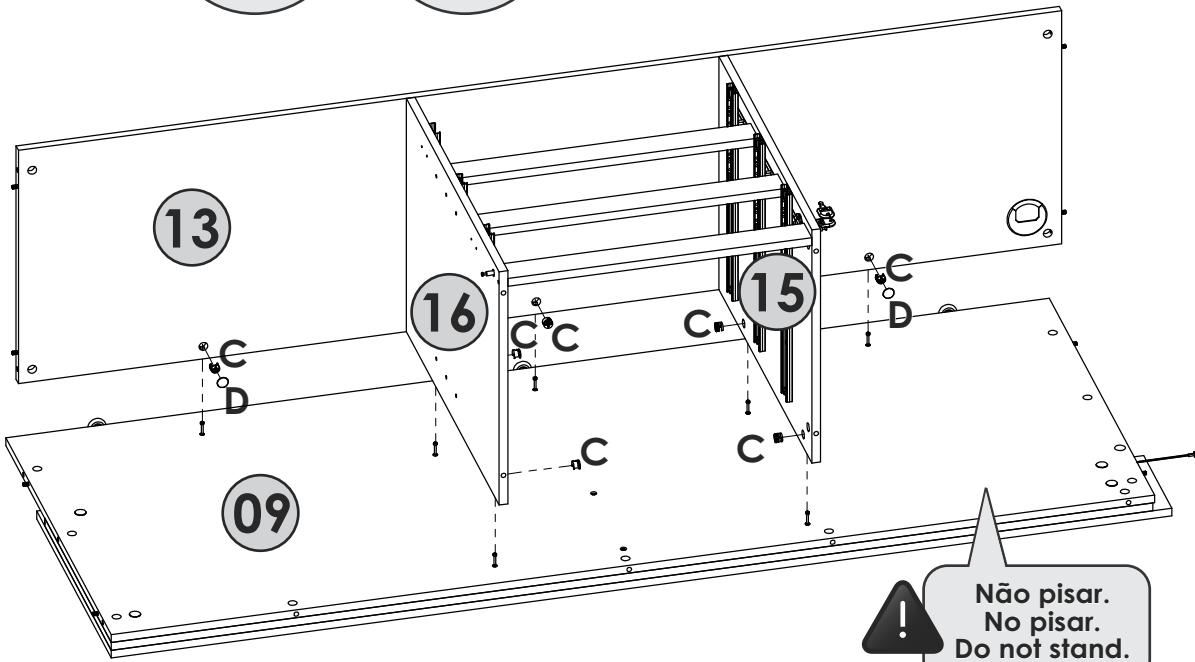
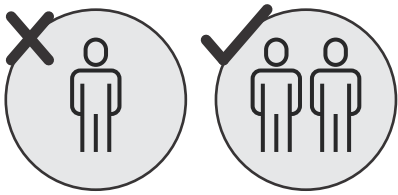

! Não pisar.
No pisar.
Do not stand.

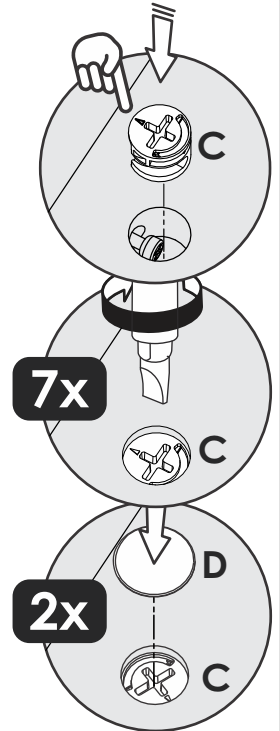

- C
07
- D
02

27

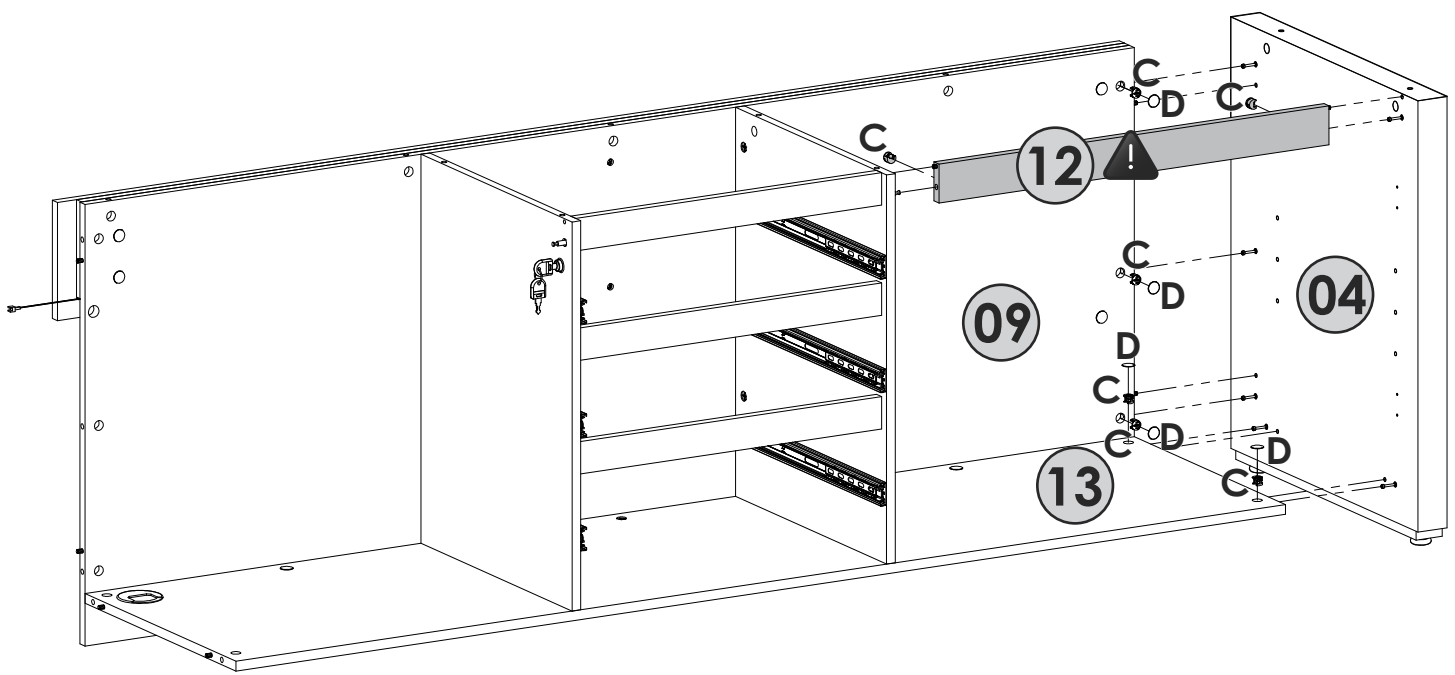
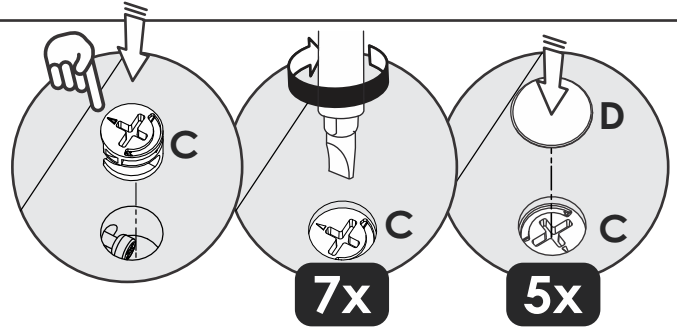
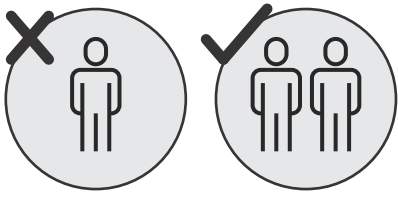

- C
07
- D
05

28

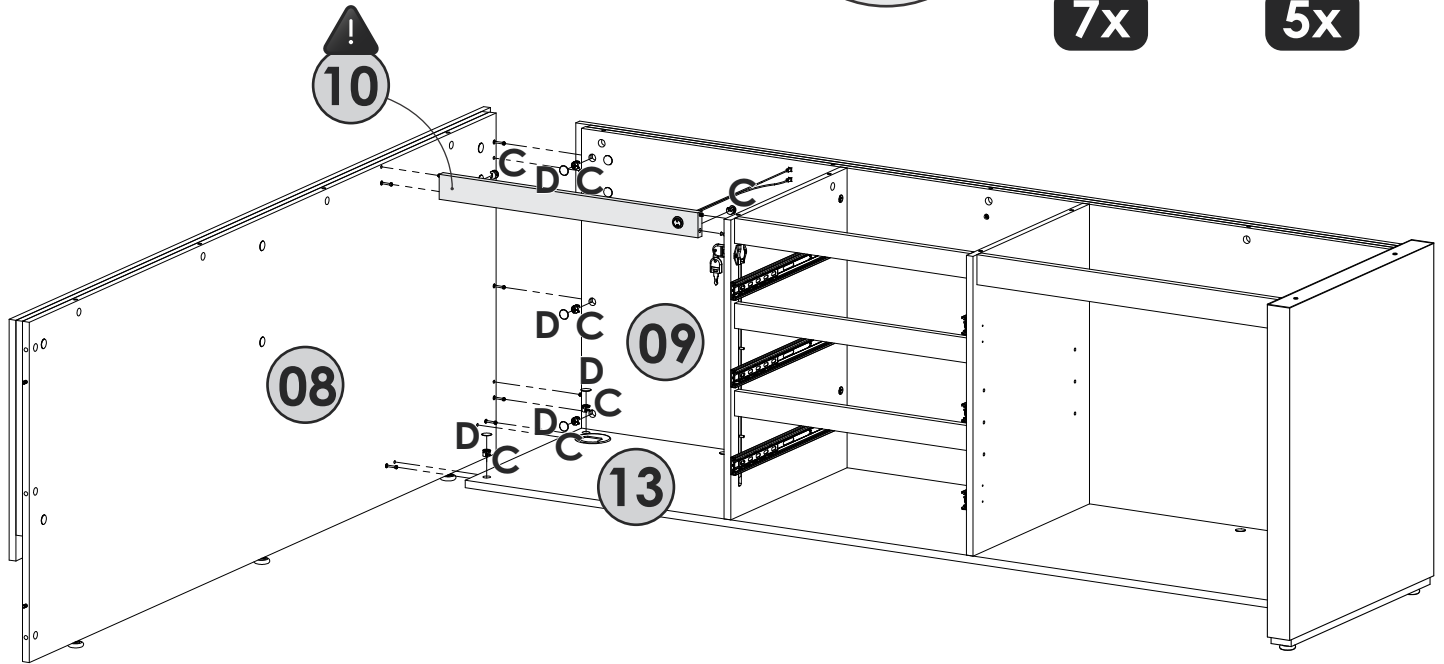
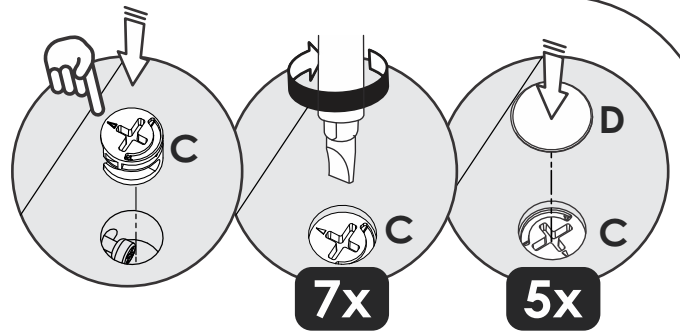
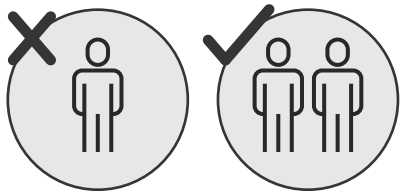

29

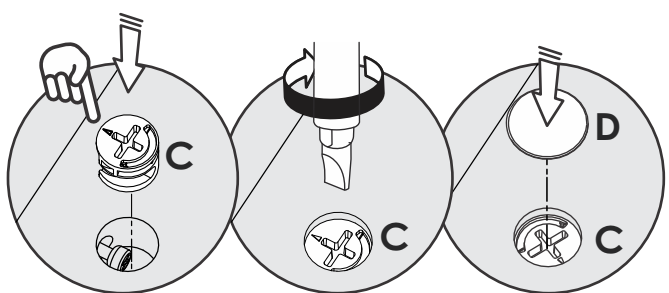
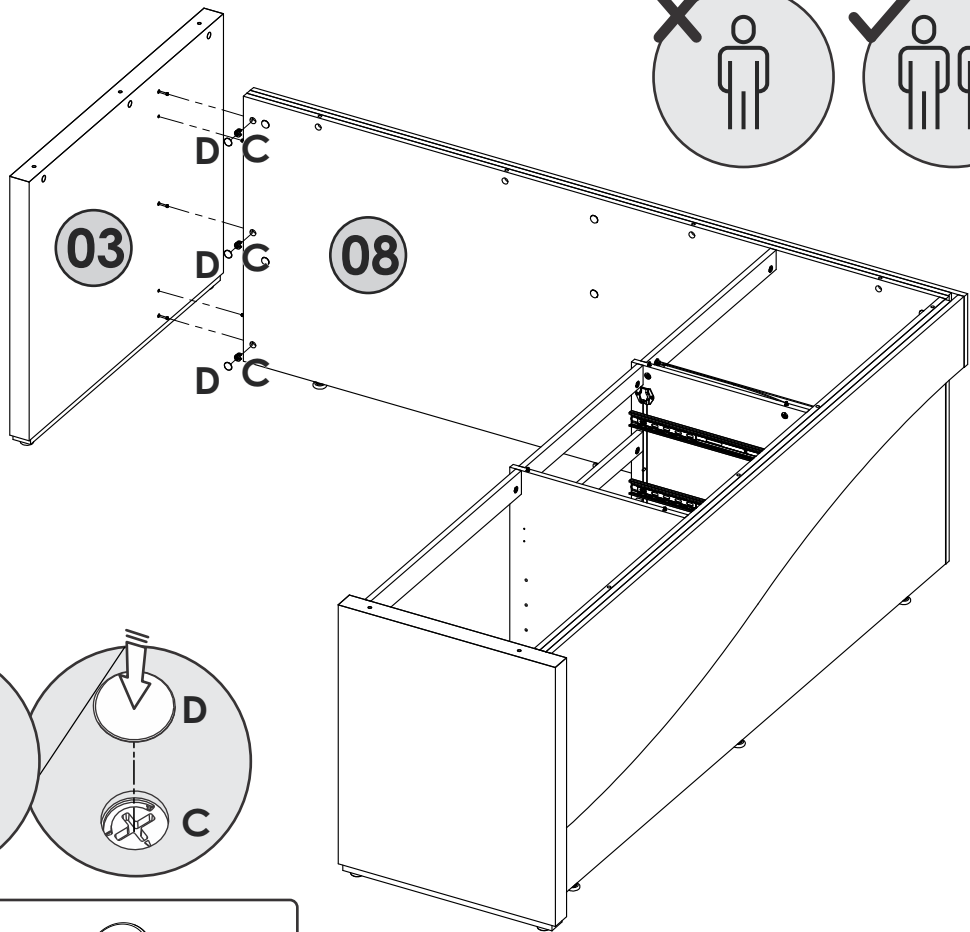
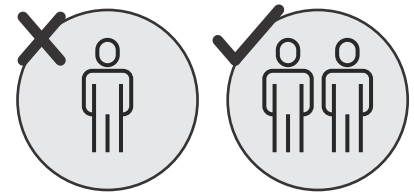

30

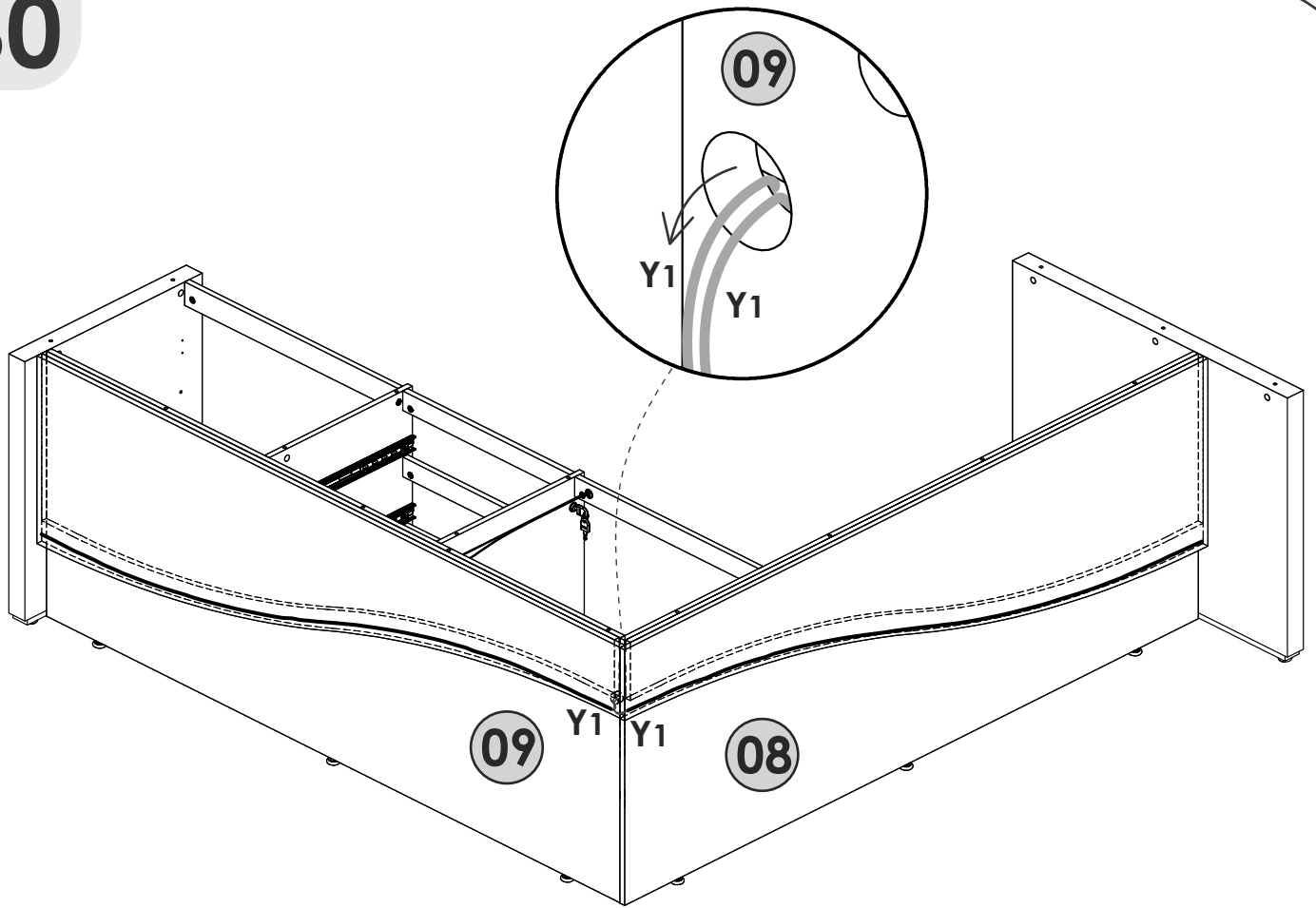

31

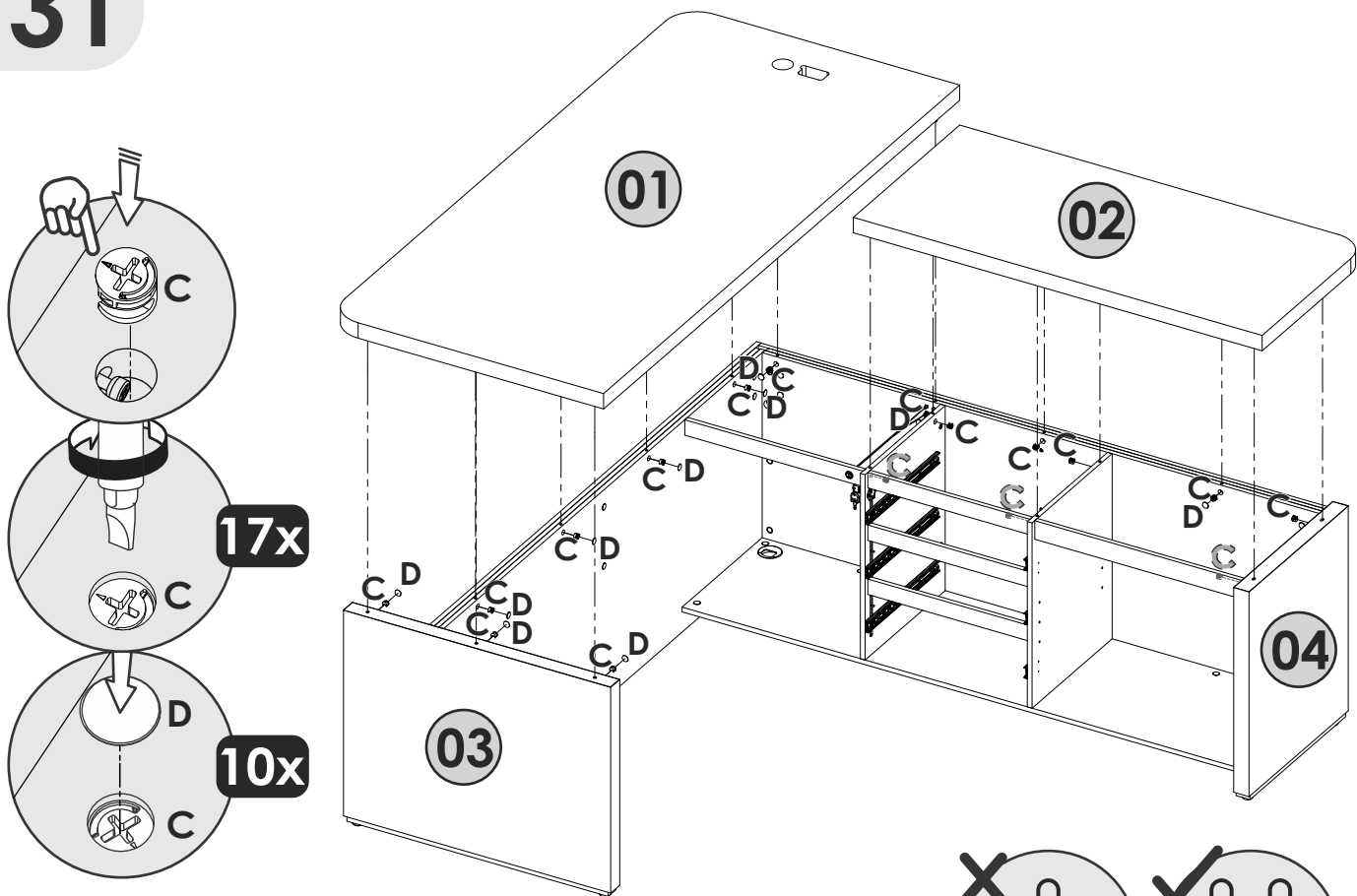

C		17	D		10
---	---	----	---	---	----



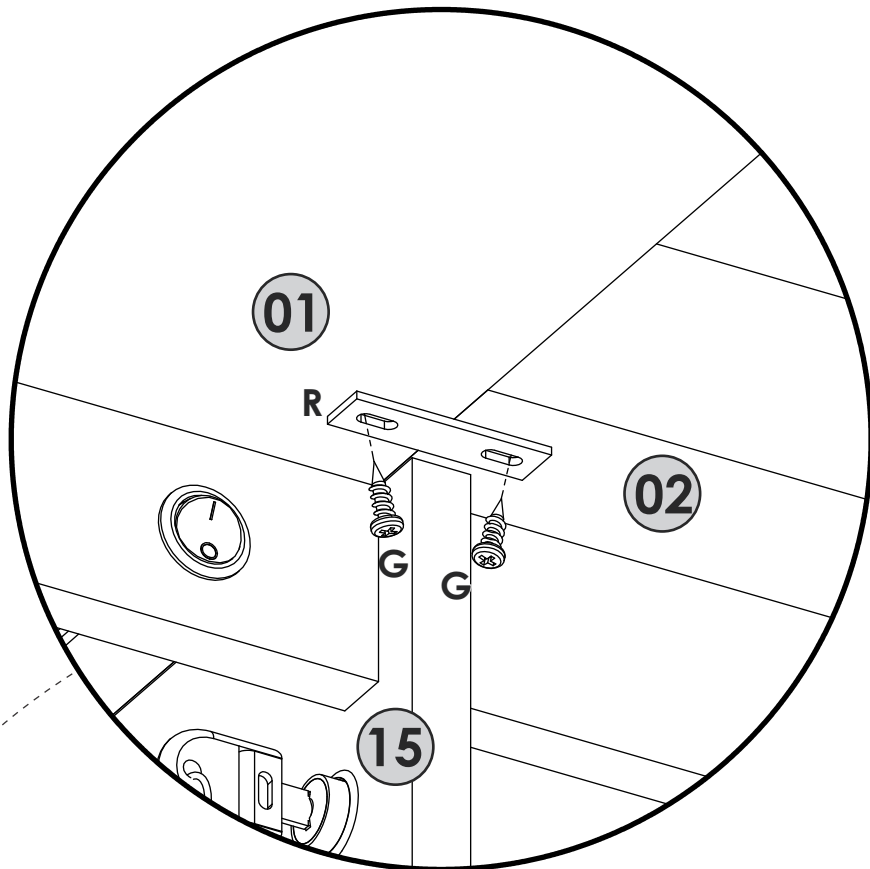
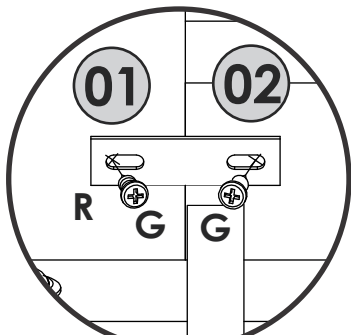

Dica: Parafuse o item "G" na posição indicada para unir os tampos.

Consejo: Atornille el elemento "G" de acuerdo al dibujo para unir las tapas.

Tip: Screw item "G" in the indicated position to join the table tops.

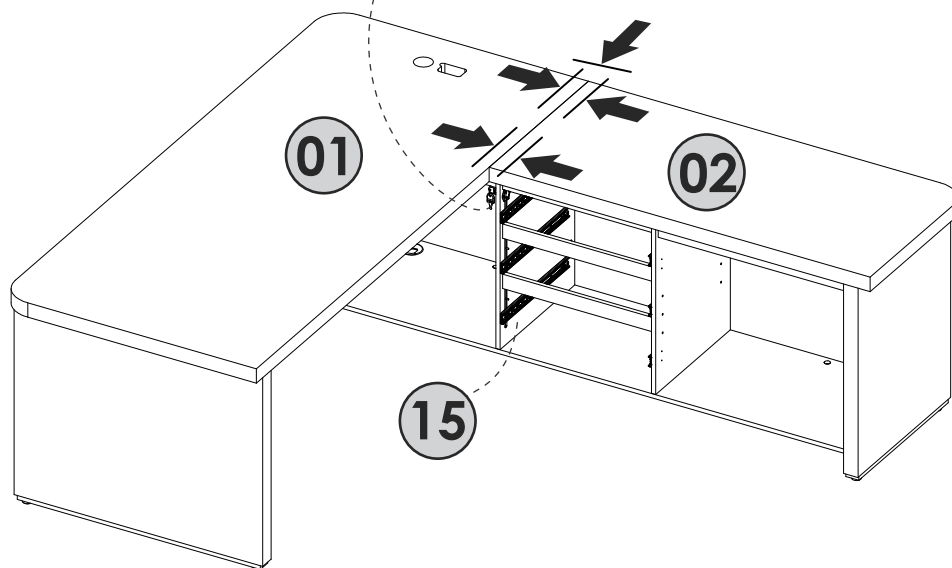

Regule as sapatas (K) para nivelar as peças 01 e 02.

Ajuste las patas (K) para nivelar las partes 01 y 02.

Adjust the feet (K) to level pieces 01 and 02.

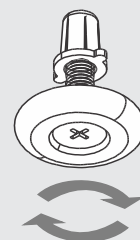

G

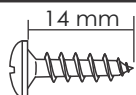

02

R



01

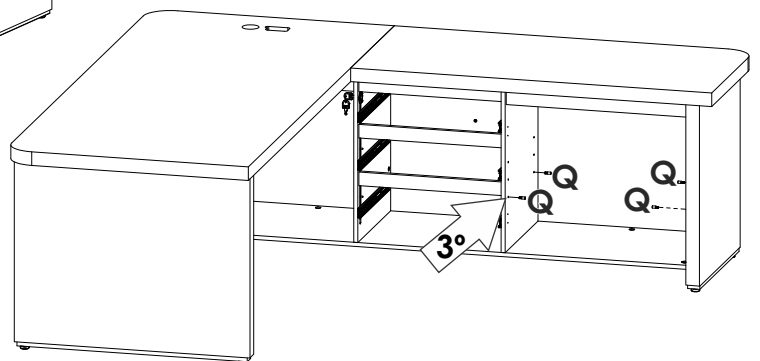
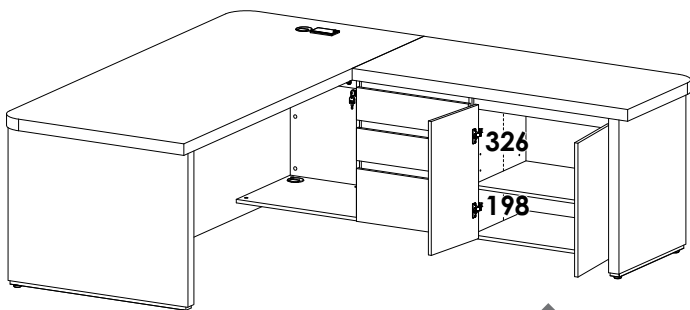
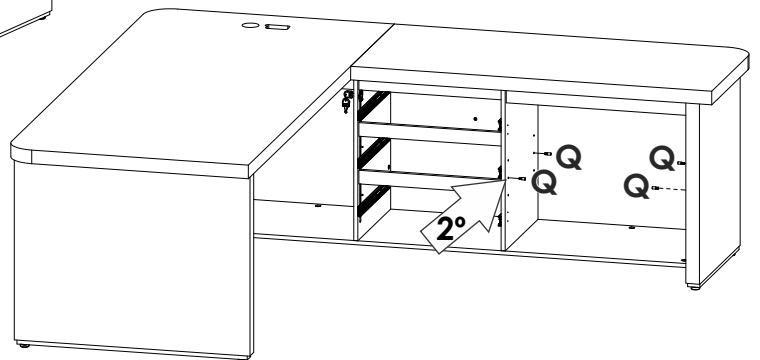
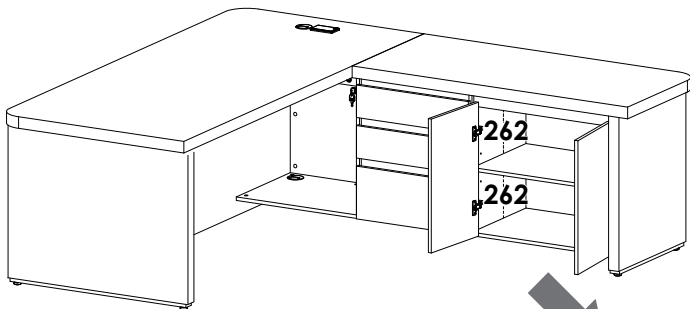
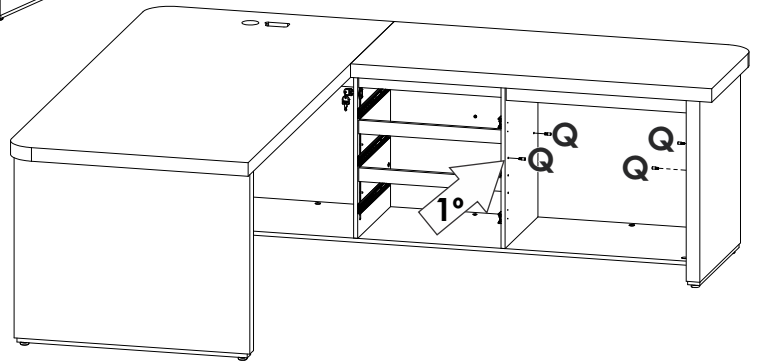
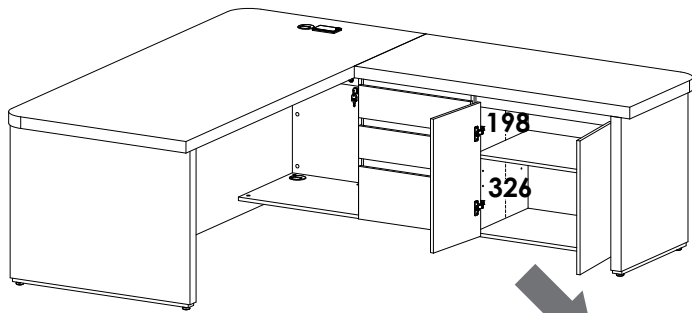

34

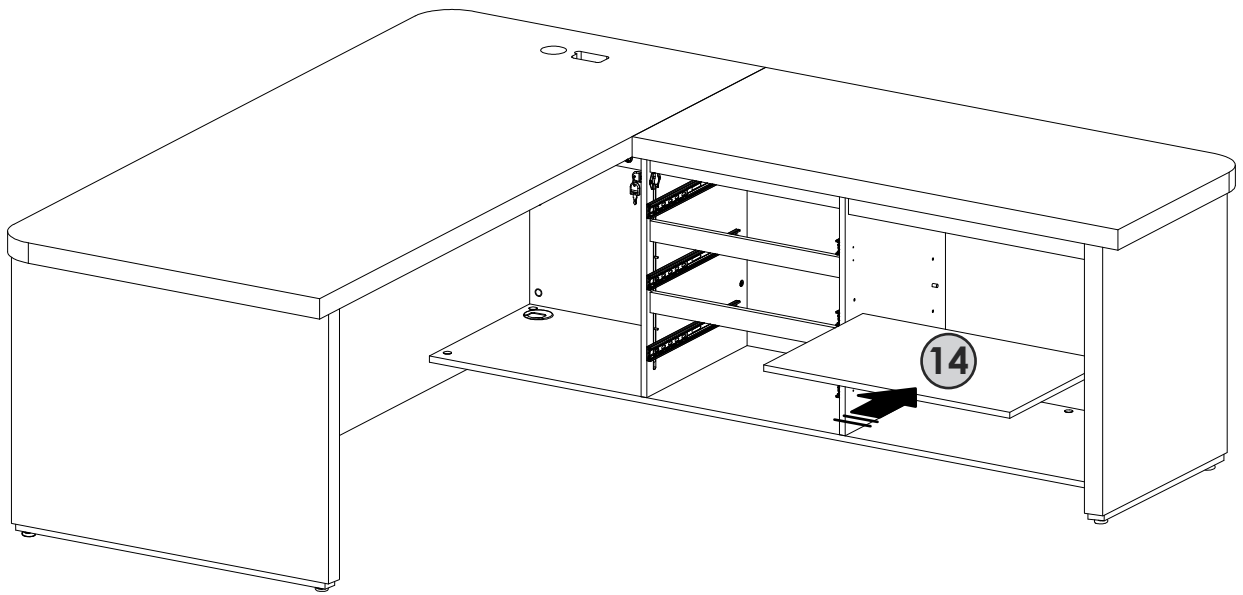

35

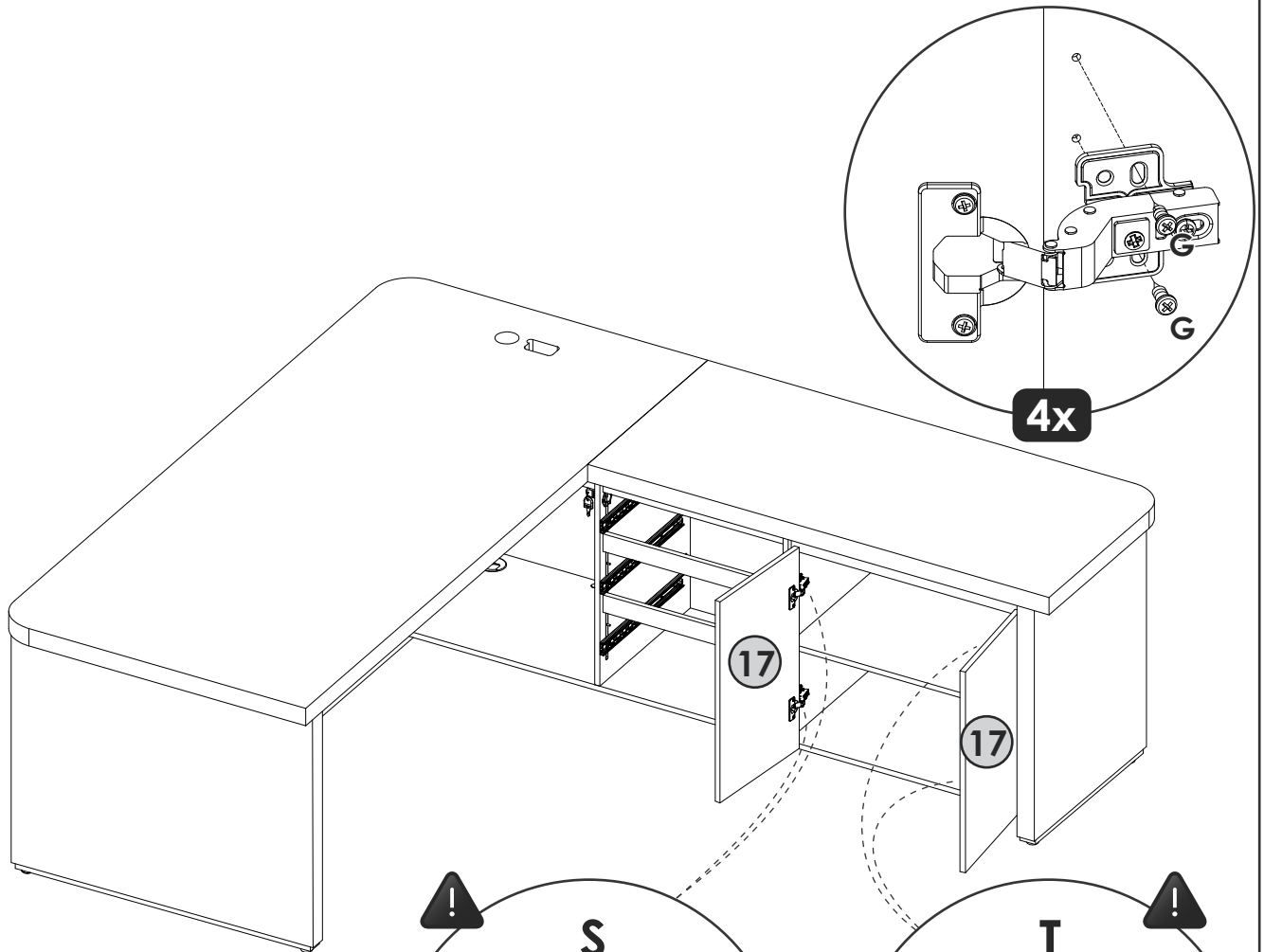

4x

17

17



S

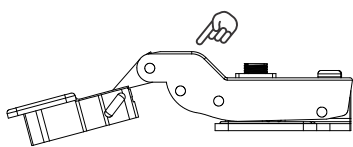

Dobradiça Curva
Bisagra Semiacodada
Half Overlay
Cod. 105458



T

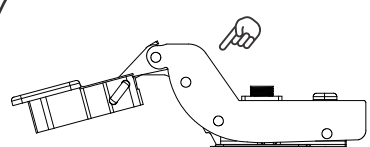

Dobradiça Super Curva
Bisagra Acodada
Inset Hinge
Cod. 109529

G

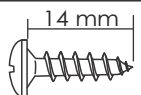

08

36

.1

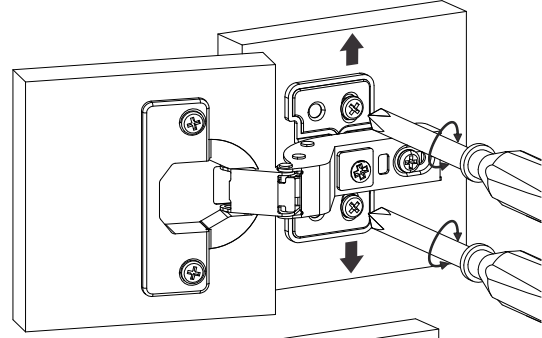

.2

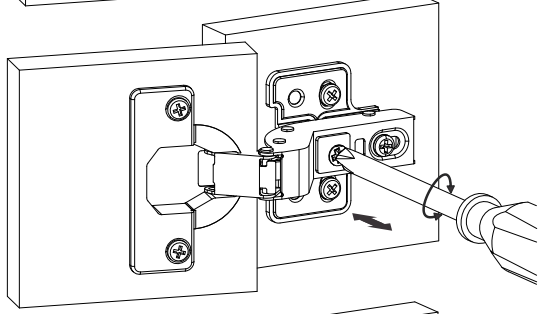

.3

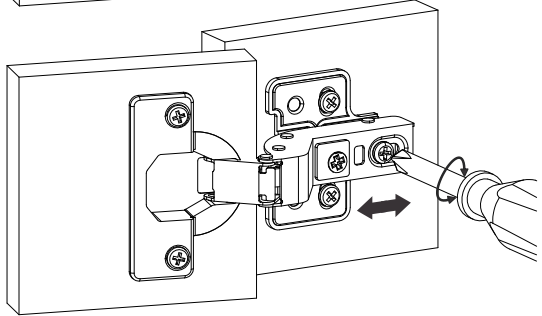

.1 .2 .3 = ✓

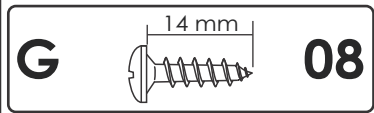
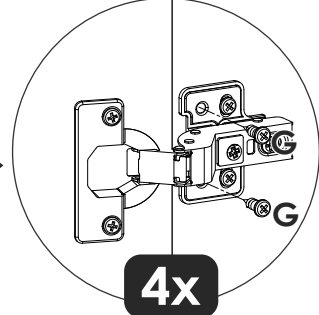

37

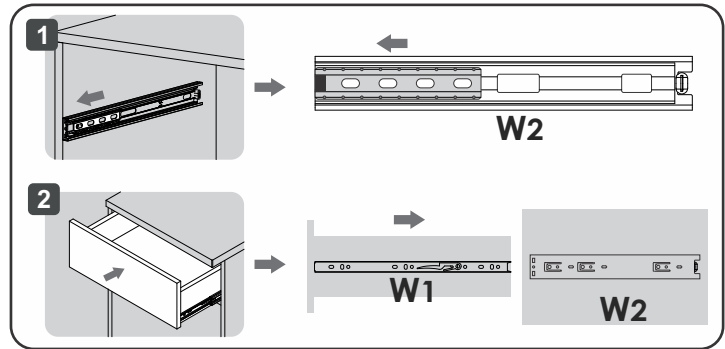
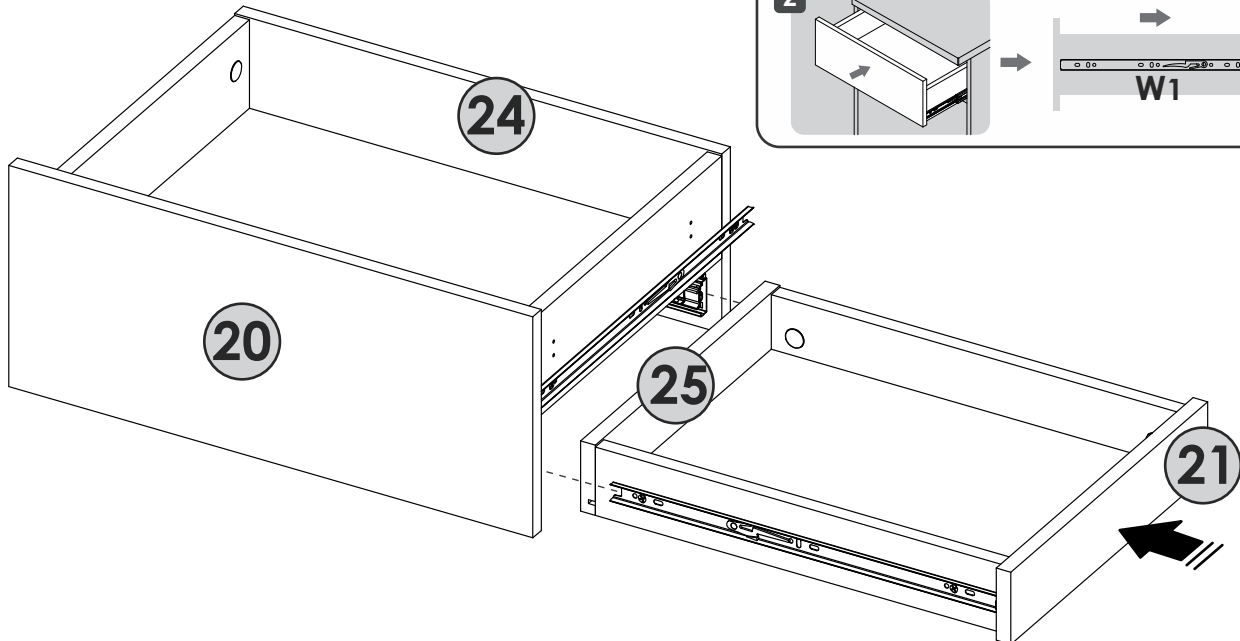

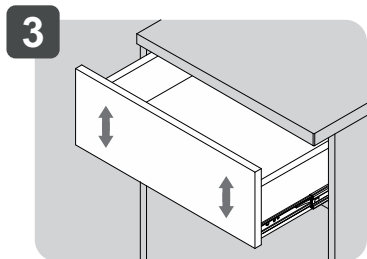
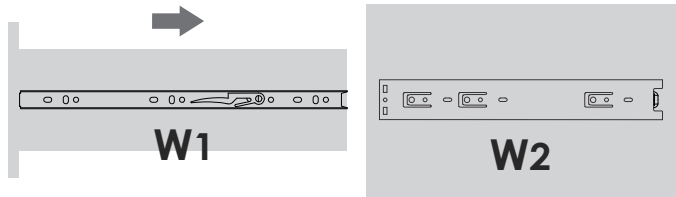
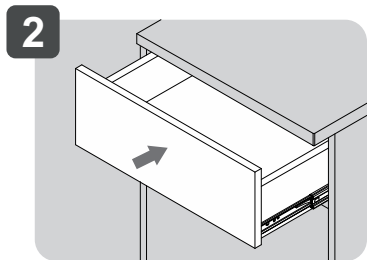
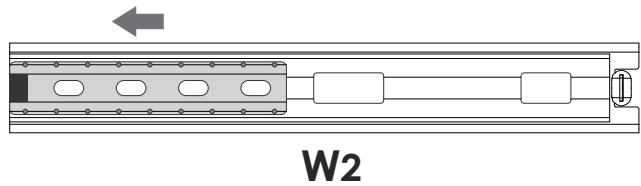
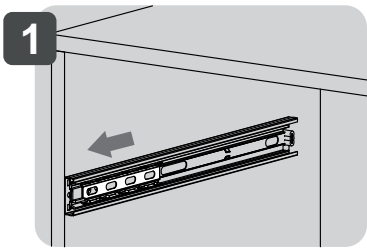
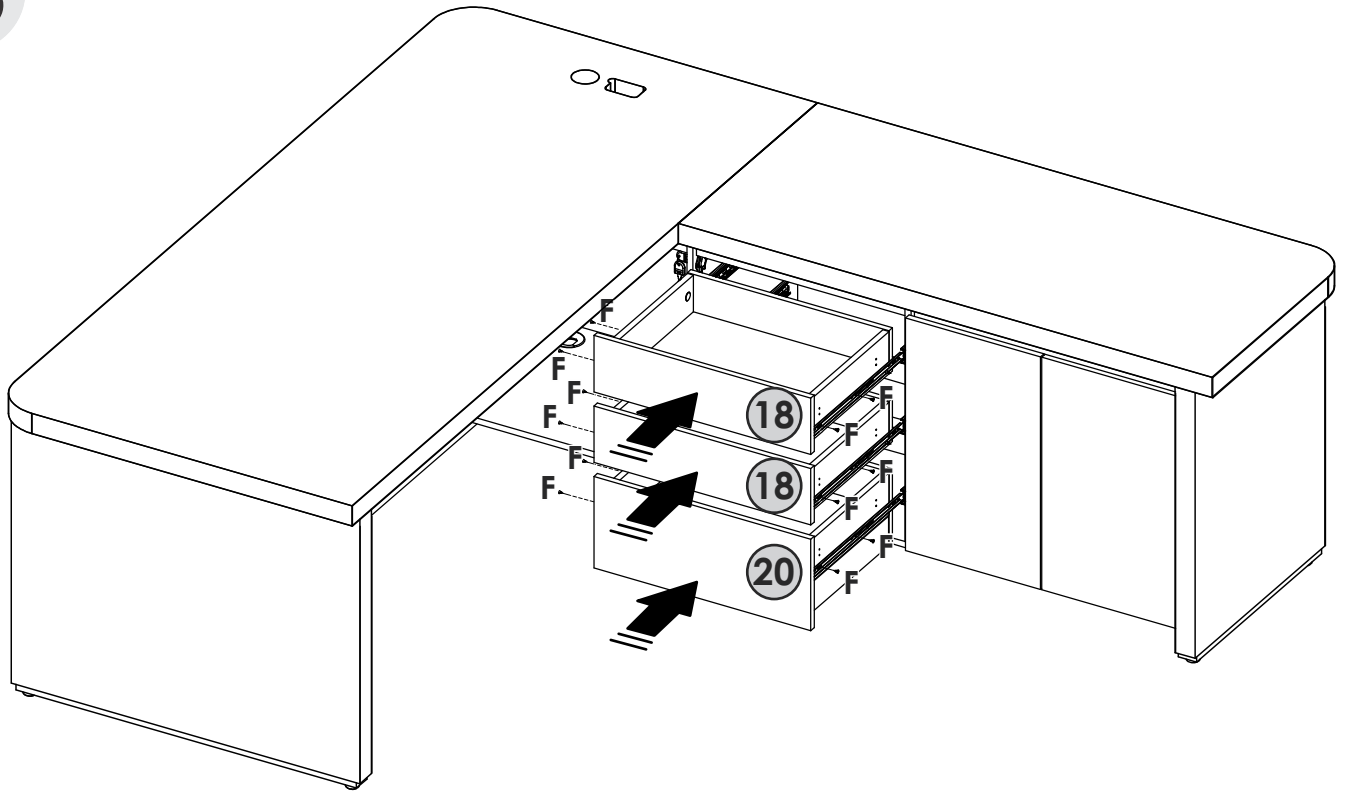

.1

Ajustar a gaveta e colocar os parafusos
 Ajustar el cajón y poner los tornillos
 Adjust the drawer and put the screws

W1

.2

W1 **F** **F**

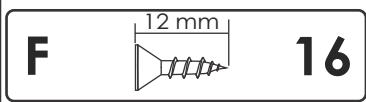

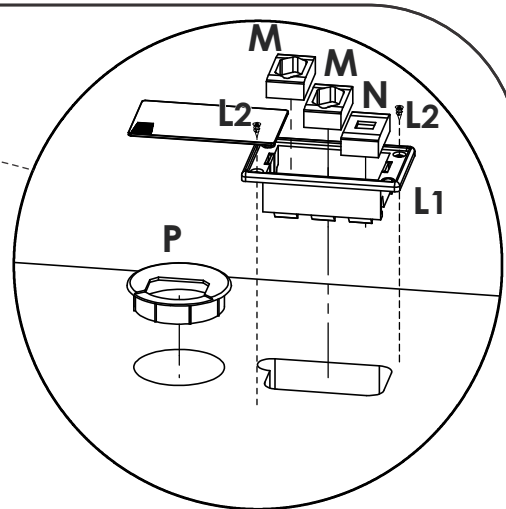
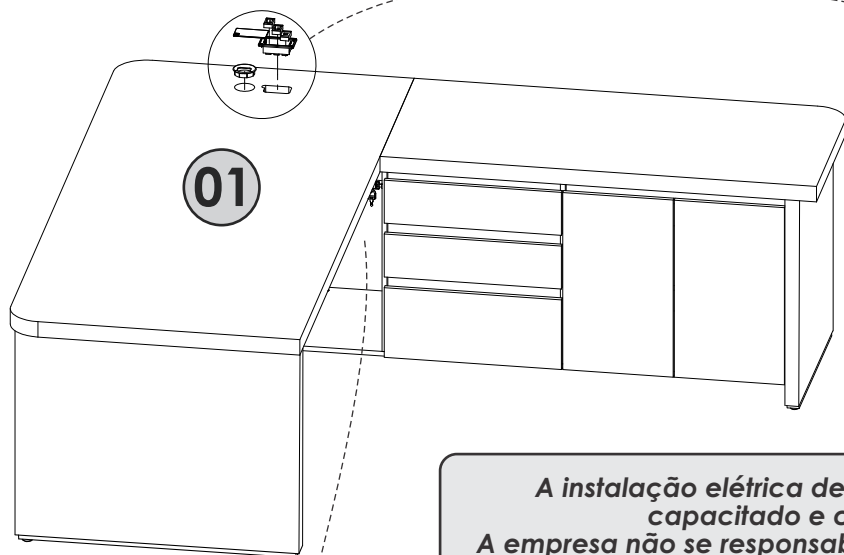

A instalação elétrica deverá ser realizada por um profissional capacitado e conforme as normas vigentes. A empresa não se responsabilizará em caso de acidentes e/ou danos ao produto em decorrência da não observância desses requisitos.

La instalación eléctrica debe ser realizada por un profesional cualificado de acuerdo con las normas vigentes. La empresa no se responsabiliza en caso de accidentes y/o daños en el producto debido al incumplimiento de estos requisitos.

The electrical installation must be carried out by a qualified professional and in accordance with the established standards. The company will not be responsible in case of accidents and/or damage to the product due to non-compliance with these requirements.

Conecte todos os cabos conforme esquema elétrico. Use os Grampos para Cabos (Y5) para organizar os fios.

Conecte todos los cables según el esquema eléctrico. Use the Cable Clip (Y5) to organize the wires.

Connect all cables according to the wiring diagram. Use la Grampa para Cables (Y5) para organizar los cables.

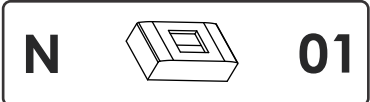
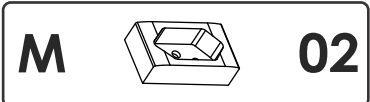
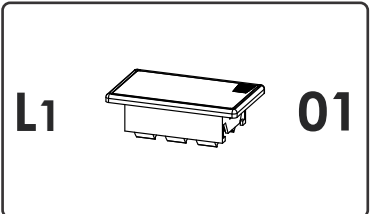
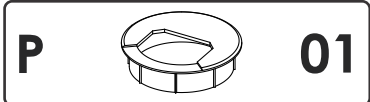
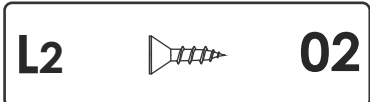
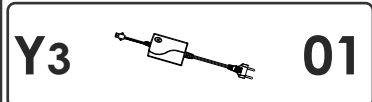
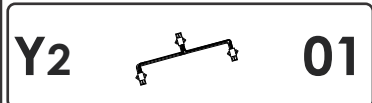
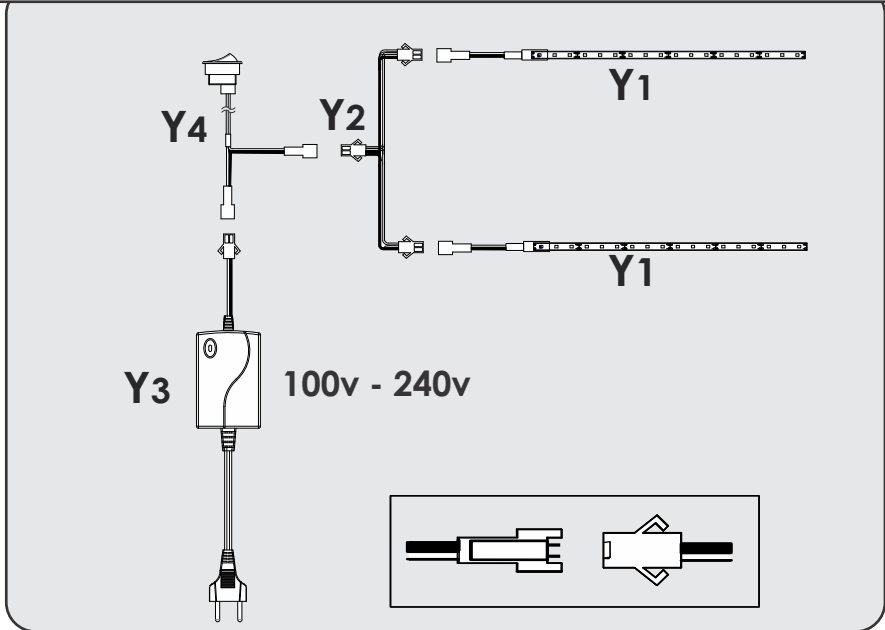

Obrigado

POR SUA CONFIANÇA EM NOSSO TRABALHO!



Esperamos que sua experiência de compra, montagem e instalação tenha sido perfeita!

Desejamos que seu móvel possa tornar seu Home Office, casa ou escritório, um ambiente muito mais agradável e organizado, fazendo seu trabalho, estudo ou descanso ser muito mais proveitoso!

APROVEITE SEU MÓVEL ARTANY!

Se tiver alguma dúvida, sugestão ou comentário, pode entrar em contato no nosso WhatsApp (41) 99242-8497, telefone (41)3556-1550, ou email artany@artany.com.br



Gostou? Compartilhe este momento e marque a gente!



@artanymoveis



ARTANY[®]
Arte em Office