

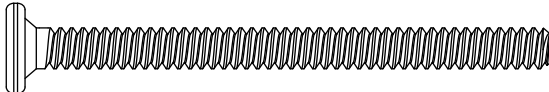

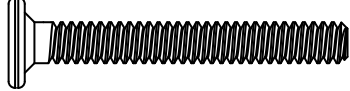



ESQUEMA DE MONTAGEM – CADEIRA LUNA/CANNES (2 un. p/ caixa)

Pág 1

RELAÇÃO DE FERRAGENS PARA 1 CADEIRA

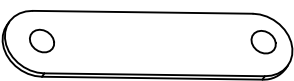
CÓD	DESENHO	QTD	NOME (ONDE USAR)
A		8	Paraf ¼" x 100 – Fixar laterais com os Pés
B		12	Paraf ¼" x 70 – Fixar laterais com os Pés
C		14	Paraf 4 x 14 – Fixar o Assento
D		3	Cantoneira 18 x 18 – Fixar o assento
E		4	Sapata – Acabamento Pés da Cadeira
F		4	Prego 8 x 8 - Fixar Sapata
G		4	Chapa de Fixação do Assento no Encosto
H		20	Porca Plástica - Unir os Pés

PESO MÁXIMO SUPORTADO: 100 Kg

DESCRIÇÃO DAS PEÇAS			
NUMERO DA PEÇA	QUANT.	NOME	DETALHES
1	2	Pé Dianteiro	440 x 60 x 25
2	2	Pé Traseiro	790 x 60 x 25
3	5	Travessas	330 x 80 x 25
4	1	Assento cadeira	400 x 430 x 120
5	1	Encosto Estofado	630 x 430 x 90

DIMENSÕES PRODUTO MONTADO: 1020 X 520 X 430

ATENÇÃO

- 1-Ler e observar atentamente toda instrução antes de iniciar a montagem.
- 2-A montagem do produto deverá ser feita em superfície limpa e plana. Aconselhamos utilizar a embalagem para forrar o chão a fim de não danificar o produto.
- 3-Os parafusos devem ser apertados periodicamente.
- 4-Evitar batidas e contatos com objetos cortantes.

LIMPEZA

- 1-Pano levemente umedecido com água, seguido de pano seco.
- 2-Não utilizar produtos químicos ou abrasivos.

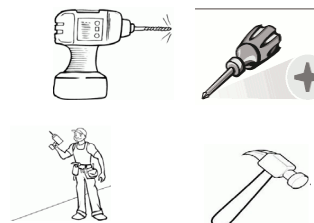
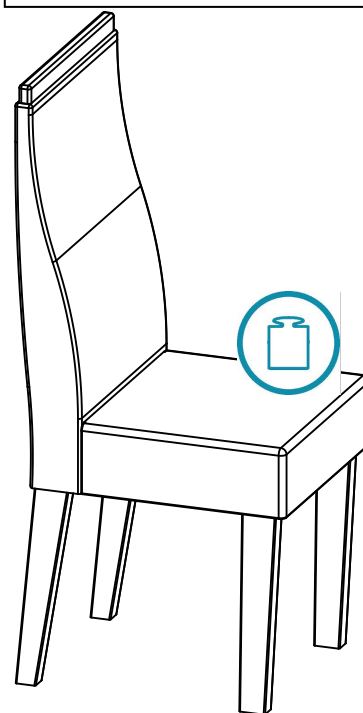

1 PESSOA

MONTANDO PASSO A PASSO

1º PASSO: MONTAR OS PÉS DA CADEIRA JUNTOS AS TRAVAS E COLOCAR AS SAPATAS NOS PÉS.

PARAFUSAR A CADEIRA SEMPRE EM TORQUE FORTE

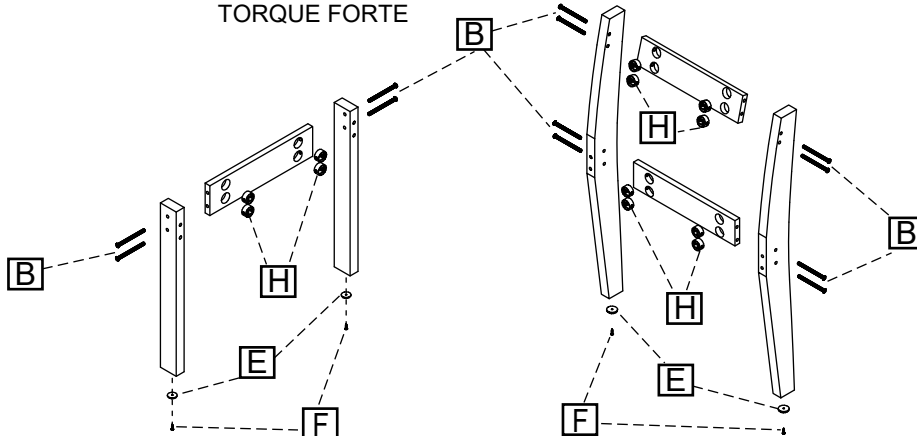
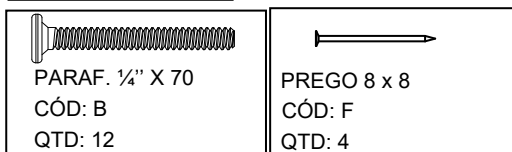

2º PASSO: MONTAR OS PÉS DA CADEIRA JUNTOS AS TRAVAS FORMANDO A BASE.

PARAFUSAR A CADEIRA SEMPRE EM TORQUE FORTE

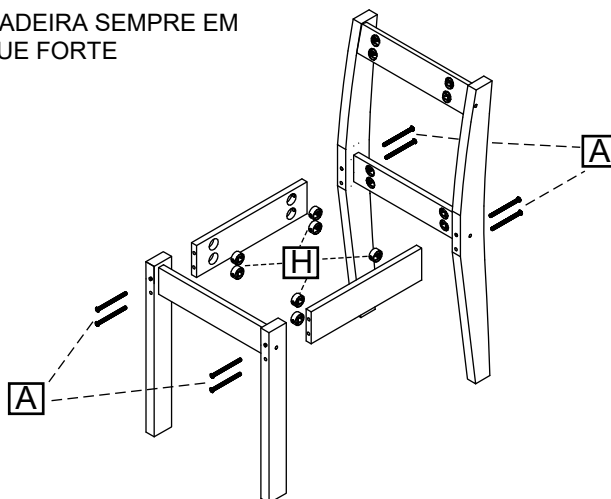
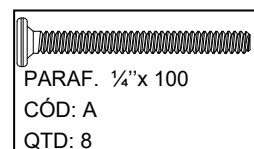

3º PASSO: PARAFUSAR O ENCOSTO COM O ASSENTO.

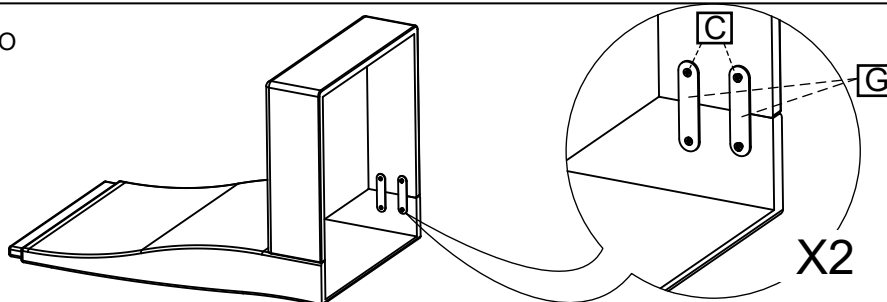
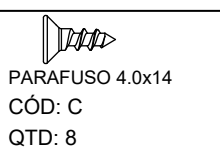
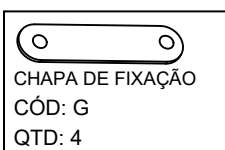

4º PASSO: PARAFUSAR A BASE DA CADEIRA COM A PARTE ESTOFADA.

