

# ***Manual de montagem***

Instrucciones de montaje Assembly instructions

## **BAM003/BAM004**

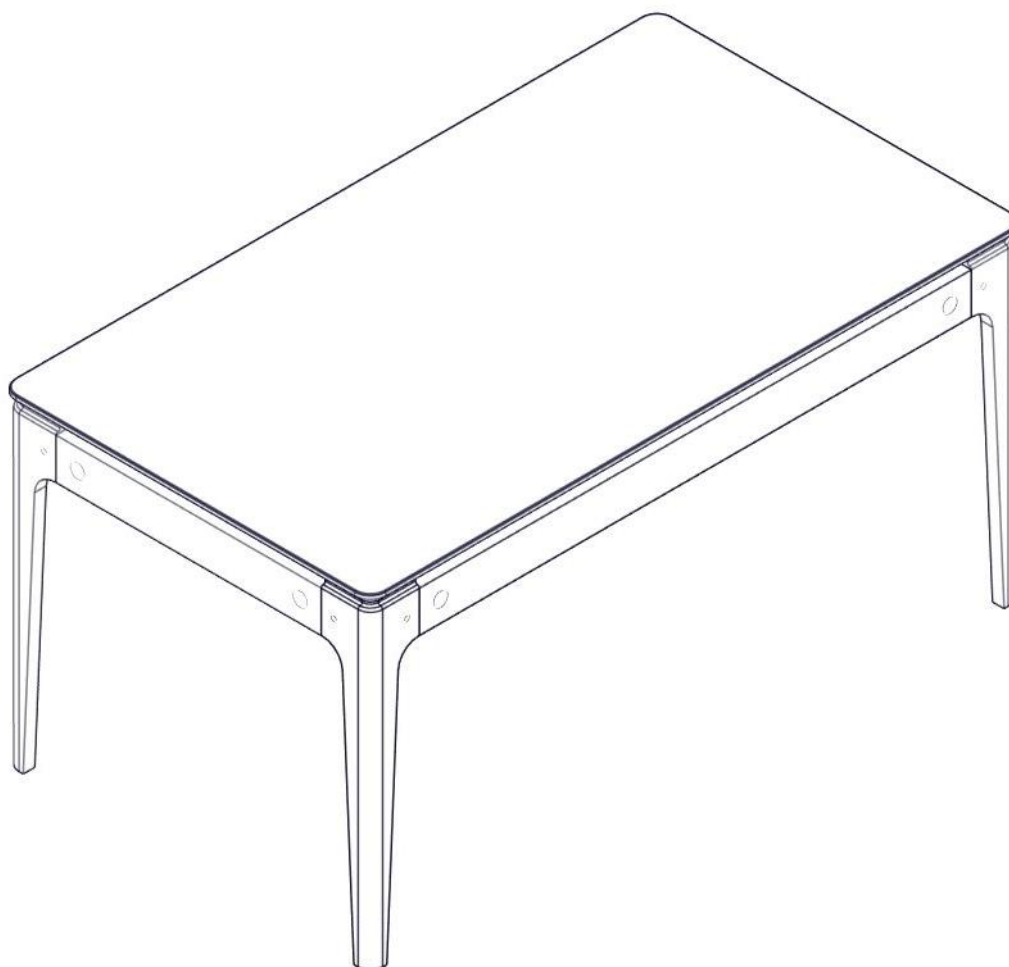

**! Imagens meramente ilustrativas !**  
Imágenes ilustrativas/Images merely illustrative.

Dúvidas? Entre em contato:  
Dudas? Ponerse em contacto:  
Doubts? Get in touch:  
(51) 3635-8839

## A montagem deve ser efetuada por 2 pessoas.

El montaje debe ser efectuada por 2 personas.

The assembly must be done by 2 people.

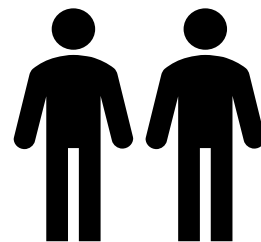

## Ferramentas necessárias para montar o móvel.

Herramientas necesarias para armar el mueble.

Tools needed to assemble the furniture.



## Dúvidas? Entrar em contato:

Dudas? Ponerse en contacto:

Doubts? Get in touch:

Fone: (51) 3635-8839

[www.kappesberg.com.br](http://www.kappesberg.com.br)



## Montar o móvel sobre uma superfície limpa e plana.

Armar el mueble sobre una superficie limpia y plana.

Assemble the furniture on a clean, flat surface.

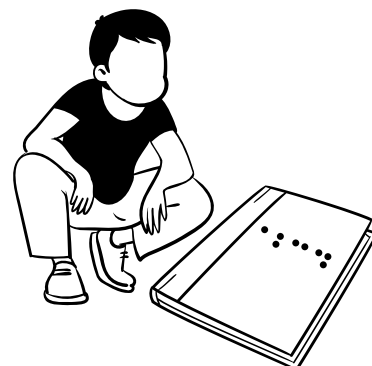



**IDENTIFICAÇÃO DAS PEÇAS / IDENTIFICACIÓN DE LAS PIEZAS PARTS**  
IDENTIFICATION

# BAM003

VISUALIZAÇÃO DO DOCUMENTO	QTD.	CÓDIGO / CODE	DESCRIÇÃO	Descripción	Description	C x L x E
	4	P102078	PÉ PARA MESA 772X120X120MM	PÉ PARA MESA 772X120X120MM	PÉ PARA MESA 772X120X120MM	772 x 120 x 30 mm
	2	P102079	SARRAFO 1348 X 90 X 24MM	SARRAFO 1348 X 90 X 24MM	SARRAFO 1348 X 90 X 24MM	1348 x 90 x 24 mm
	2	P102081	SARRAFO 648 X 90 X 24MM	SARRAFO 648 X 90 X 24MM	SARRAFO 648 X 90 X 24MM	648 x 90 x 24 mm
	1	P102097	SARRAFO 836X60X SARRAFO 836 X 60 X28MM	SARRAFO 836X60X SARRAFO 836 X 60 X28MM	SARRAFO 836X60X SARRAFO 836 X 60 X28MM	836 x 60 x 28 mm

# BAM004

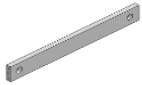
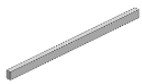
VISUALIZAÇÃO DO DOCUMENTO	QTD.	CÓDIGO / CODE	DESCRIÇÃO	Descripción	Description	C x L x E	L x W x T
	4	P102078	PÉ PARA MESA 772X120X120MM	PÉ PARA MESA 772X120X120MM	PÉ PARA MESA 772X120X120MM	772 x 120 x 30 mm	30.39 x 4.72 x 1.18 in
	2	P102093	SARRAFO 1748 X 90 X 24MM	SARRAFO 1748 X 90 X 24MM	SARRAFO 1748 X 90 X 24MM	1748 x 90 x 24 mm	68.82 x 3.54 x 0.94 in
	2	P102266	SARRAFO 748 X 90 X 24MM	SARRAFO 748 X 90 X 24MM	SARRAFO 748 X 90 X 24MM	748 x 90 x 24 mm	29.45 x 3.54 x 0.94 in
	1	P102268	SARRAFO 934 X 60 X 28MM	SARRAFO 934 X 60 X 28MM	SARRAFO 934 X 60 X 28MM	934 x 60 x 28 mm	36.77 x 2.36 x 1.10 in

# BAM003

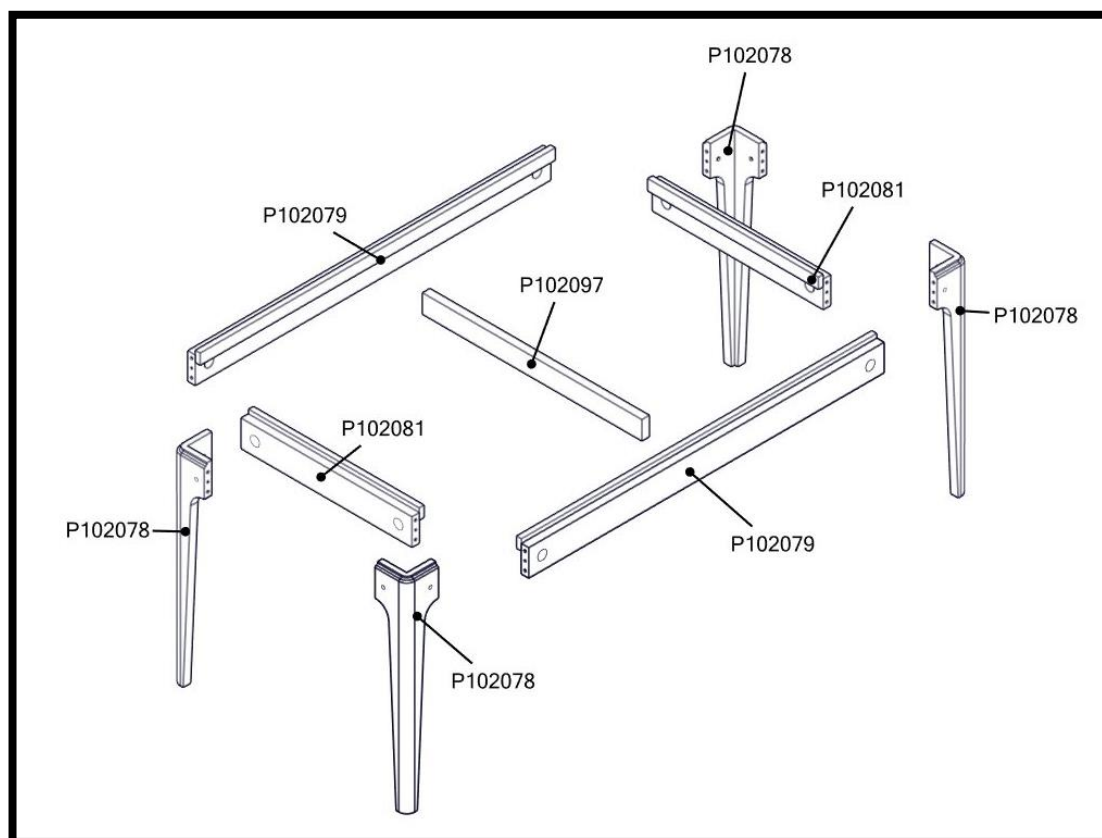

# BAM004

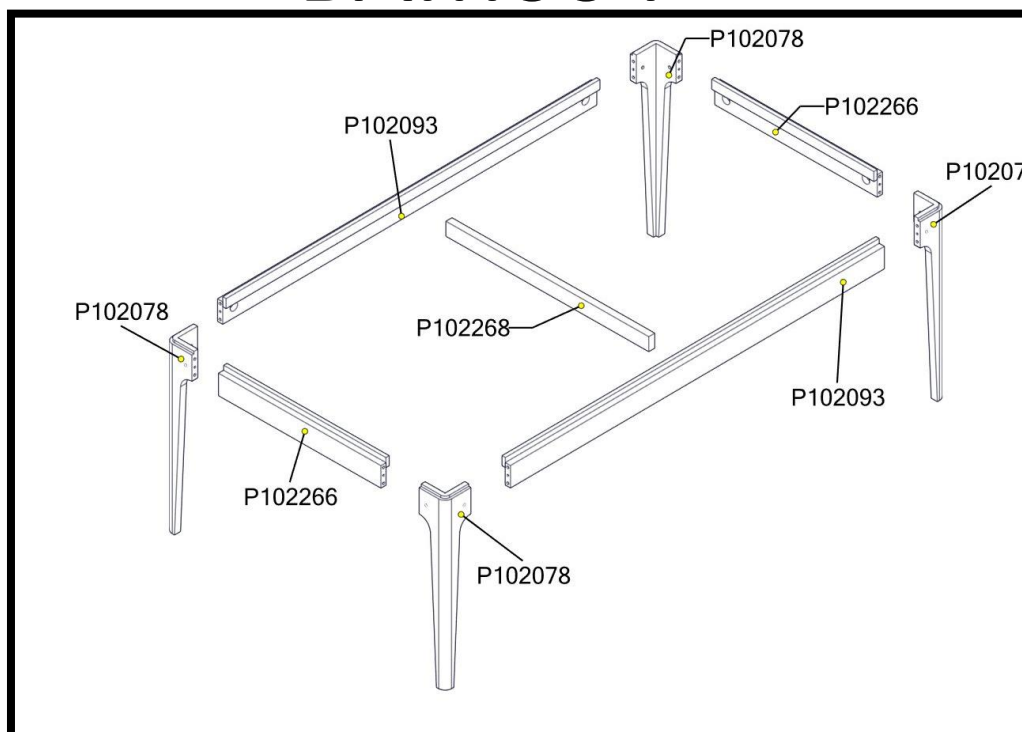







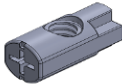

## IDENTIFICAÇÃO DOS ACESSÓRIOS / IDENTIFICACIÓN DE ACCESORIOS IDENTIFICATION OF ACCESSORIES

**NOTAS: A separação dos acessórios antes de iniciar a montagem facilitará a mesma. Em caso de dúvida na identificação, coloque o acessório sobre a régua.**

Nota: Separar los accesorios antes de iniciar el montaje facilitará el mismo. En caso de duda en la identificación, coloque el accesorio en la regla.

NOTE: Separating the accessories before starting assembly will make it easier. In case of doubt in the identification, place the accessory on the ruler.

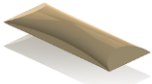
	QTD	ITEM	DESCRICAÇÃO
	8	050684	HASTE 90 MM ROSCA 1/4 ( ZINCO BRANCO)
	8	050686	ARRUELA MEIA LUA (SEM ACABAMENTO)
	8	050685	PORCA CILINDRICA 10 X 20 MM ROS. 1/4 (R) ( ZINCO BRANCO)
	8	019959	PORCA SEX. 1/4" CHV 7/16 ZINCADA BRANCA (COD. 0903153411)
	6	000899	CANTONEIRA PLASTICA PRETA
	24	004214	P.CHATO 3,5 X 14 CAB. PHILLIPS REBAIXADA ZB
	16	069083	CAVILHAS DE MADEIRA 10X50 UVA JAPONESA/EUCALIPTO
	1	050693	CHAVE BOCA P/ ACESSORIOS ZB/BC
	2	076556	CANTONEIRA 44X45 PRETO FOSCO
	8	005256	PARAFUSO CHATO 4,0 X 20 BC
	2	074319	COLA SACHE 20GRAMAS FRANK TB50

**IDENTIFICAÇÃO DOS ACESSÓRIOS / IDENTIFICACIÓN DE ACCESORIOS**  
**IDENTIFICATION OF ACCESSORIES**

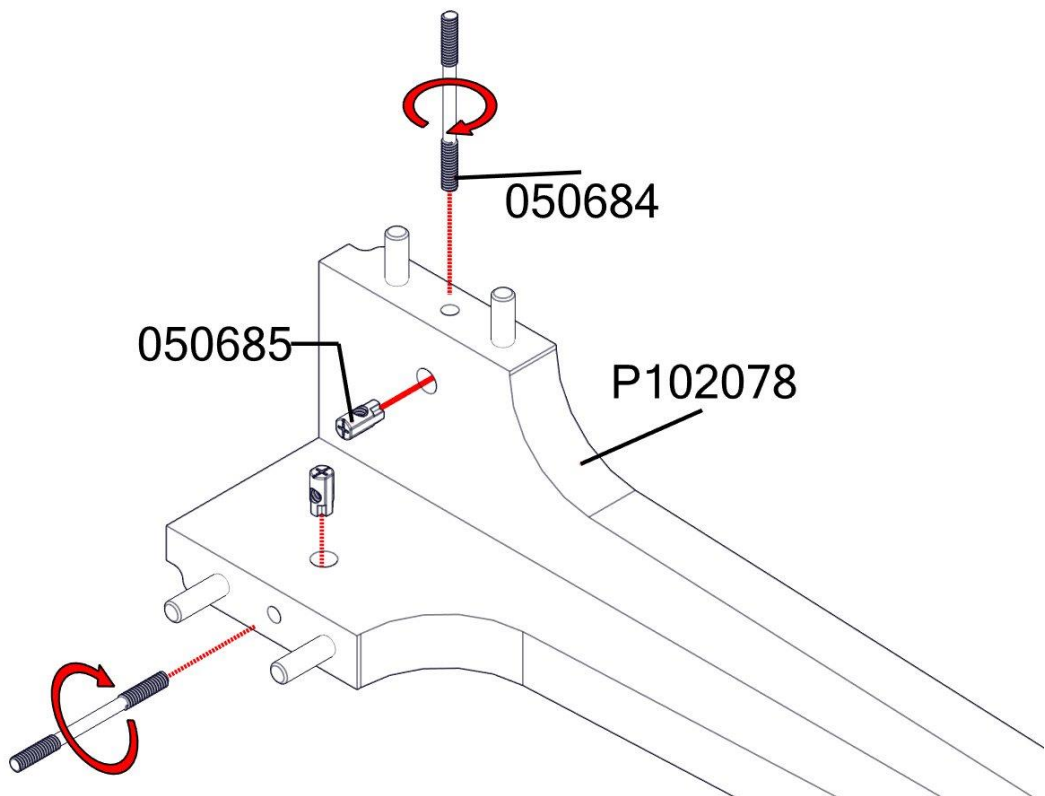
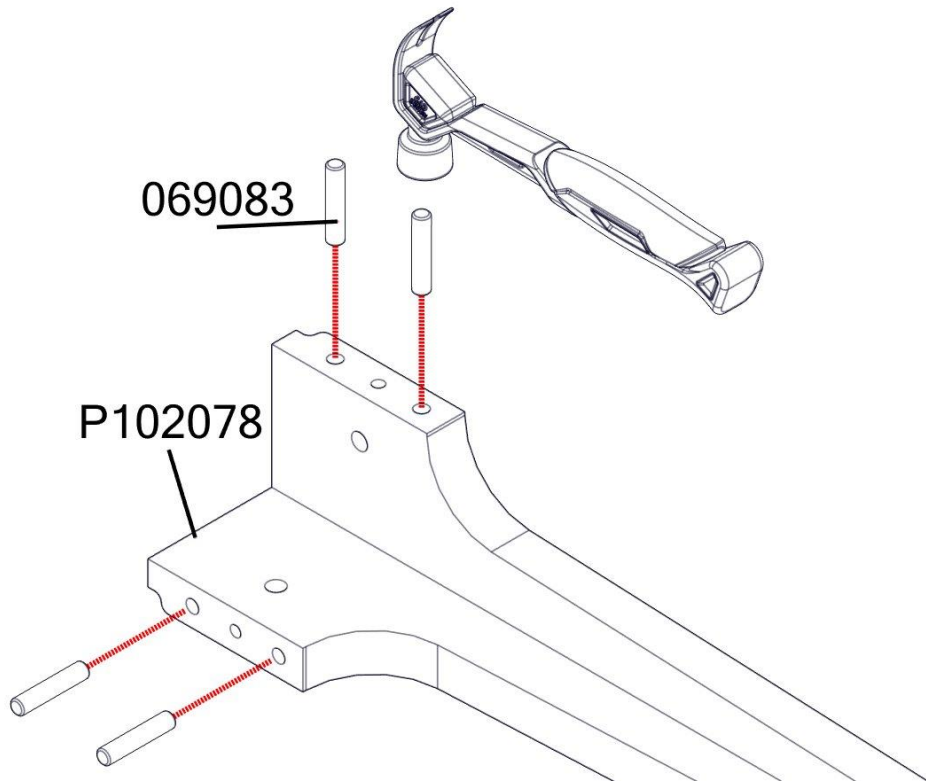

## INSTALAÇÃO MINIFIX

Identificar seta no corpo do tambor de minifix. A seta DEVE apontar para o buraco na borda do painel. Empurrar o tambor até o buraco.

## INSTALACIÓN DE LA LEVA

Identifique la flecha en la cabeza de la leva. La flecha DEBE apuntar hacia el orificio del borde del panel. Empuje la leva hasta el fondo del orificio.

## INSTALLING CAM

Identify arrow on head of cam. Arrow MUST point toward hole in edge of panel. Push cam all the way down into hole.

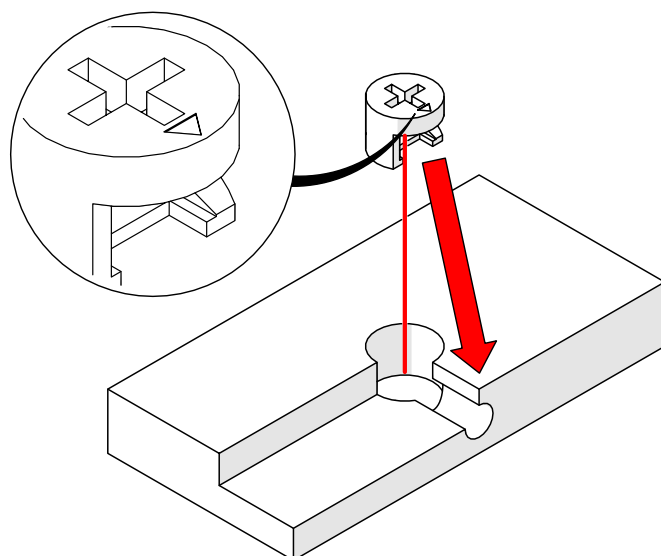

## ALINHAMENTO DO TAMBOR E PARAFUSO

A seta do tambor de minifix deve ser aponta para o buraco e inserir o parafuso do minifix do tambor contido no buraco. Certifique-se de que as peças se unam.

## ALINEACIÓN DE LA LEVA Y EL PASADOR

Asegúrese de que la flecha de la leva apunte hacia el orificio e inserte la clavija de la leva en el orificio. Asegúrese de que las piezas se unen.

## CAM AND DOWEL ALIGNMENT

Ensure the arrow on the cam points toward hole and insert cam dowel into hole. Make sure pieces join together.

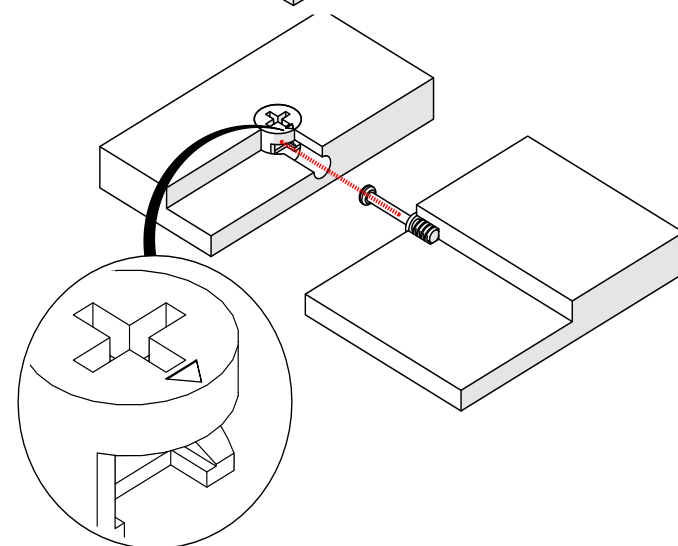

## CÂMARA DE COMPENSAÇÃO DE TENSÃO

Use uma chave de fenda para girar a came. Girar o tambor minifix (no sentido horário) até que esteja totalmente apertado. Ligeiramente mais de meia volta.

## APRIETE DE LA LEVA

Utilice un destornillador para girar la leva. Gire la leva (en el sentido de las agujas del reloj) hasta que esté completamente apretada. Un poco más de media vuelta.

## TIGHTENING CAM

Use screwdriver to turn cam. Turn cam (clockwise) until fully tightened. Slightly more than half a turn.

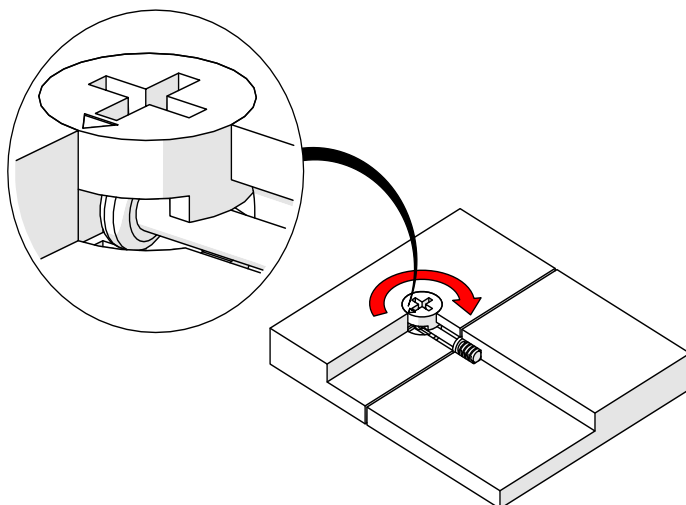

## PASSO / PASO / STEP 1

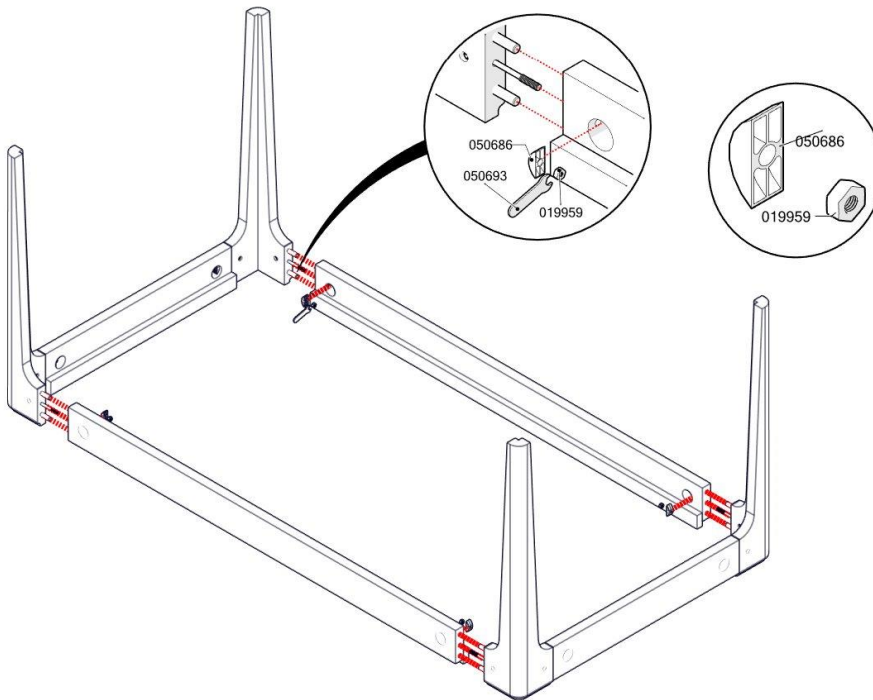

## PASSO / PASO / STEP 2

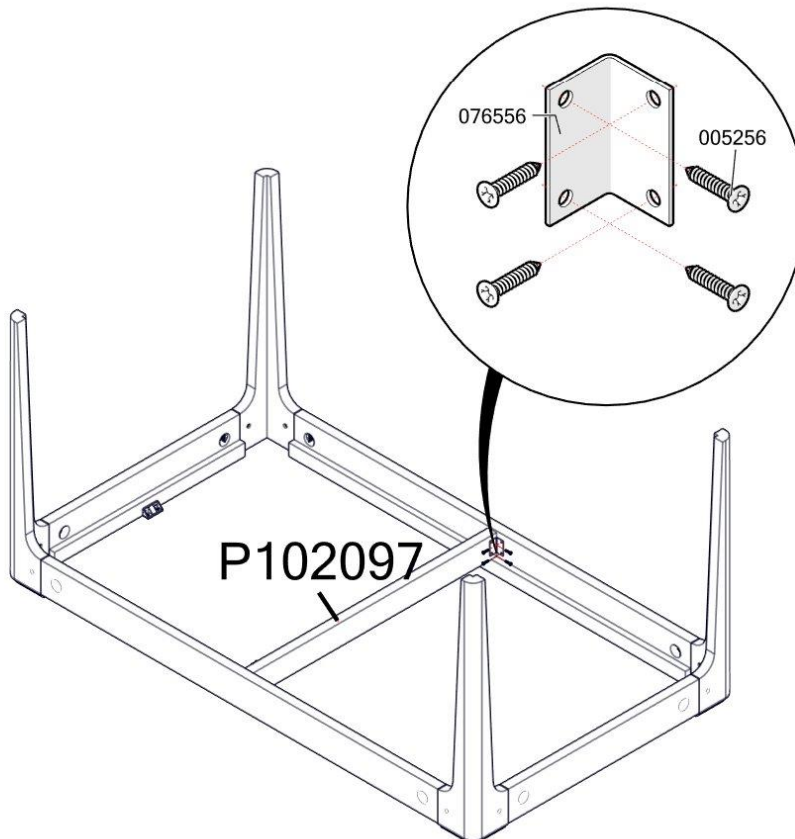

FERRAMENTA NÃO FORNECIDA



Para facilitar o processo de montagem utilize uma parafusadeira, caso não tenha uma em mãos poderá ser utilizado uma chave de fenda.



## PASSO / PASO / STEP 3

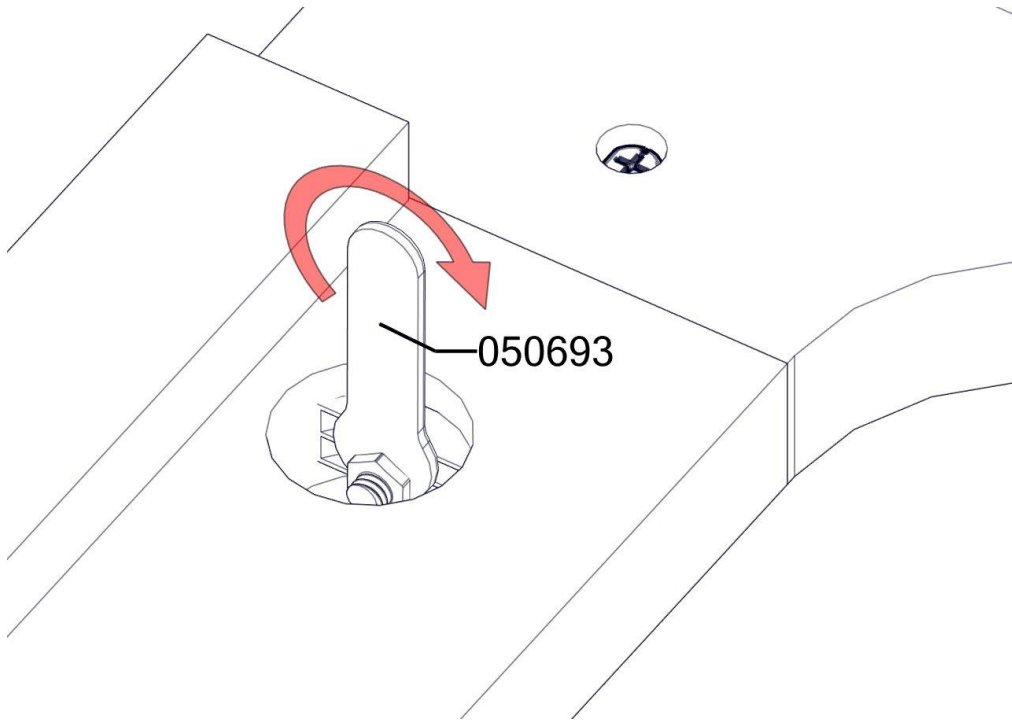

## PASSO / PASO / STEP 4

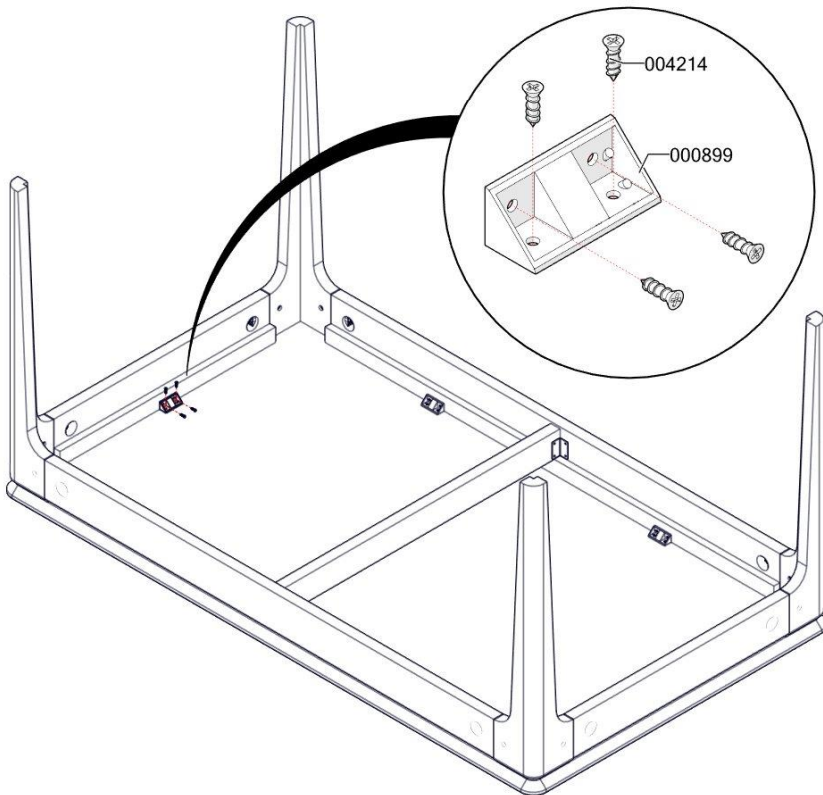

PARA FIXAR O  
TAMPO É  
NECESSÁRIO  
CENTRALIZÁ