

Dorípel

móveis

MANUAL DE MONTAGEM
ASSEMBLE INSTRUCTONS
INSTRUCCIONES DE ARMADO

RP 85400
RP 485400
Roupeiro 04 Pts

Acceça a Instrução de montagem completa pelo QRCode.

Access the complete assembly instructions via QRCode.

Accede las instrucciones de montaje completas mediante QRCode.



RP 85400

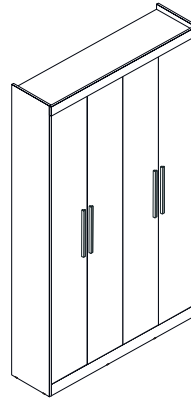

RP 485400

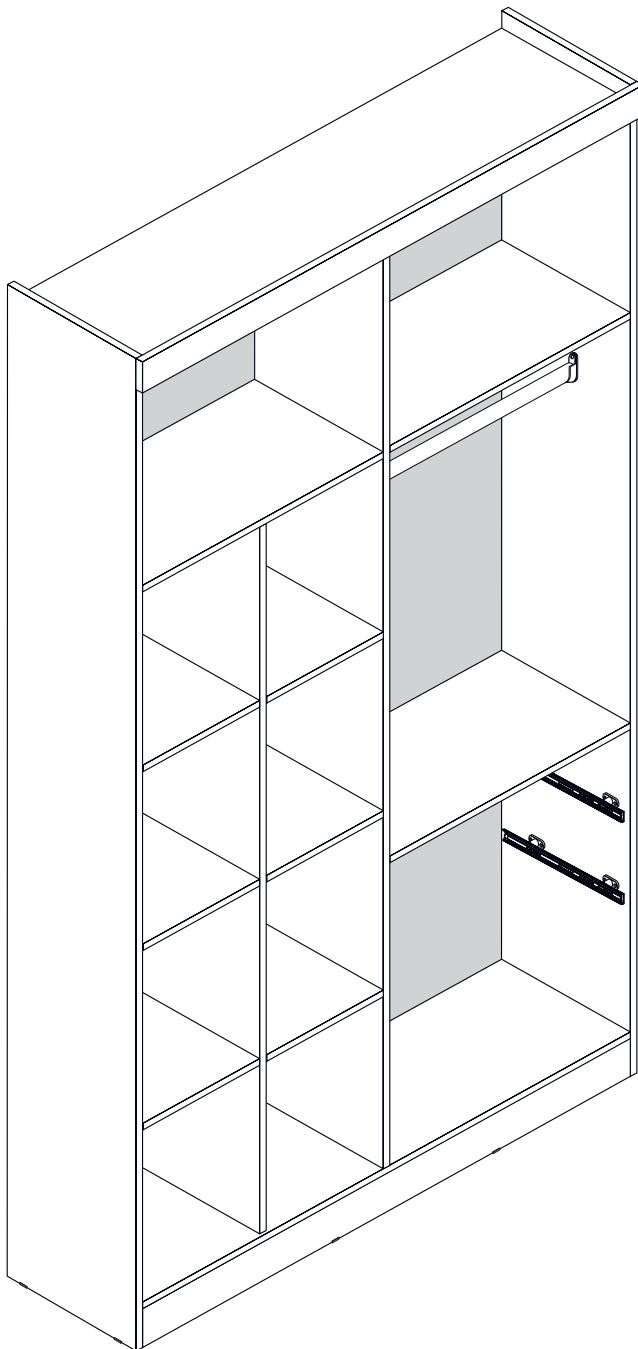
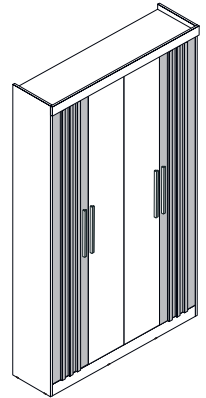

INSTRUÇÕES DE MONTAGEM DO ROUPEIRO

- 1- Começa preparando o espaço onde vai ser montado o roupeiro. Forre o chão para que não arranhe o móvel.
 - 2- Ter as ferramentas necessárias como: parafusadeira, chave de fenda, etc.
 - 3- Abrir as caixas e conferir as peças conforme está no manual.
 - 4- Fazer a separação das peças como indicado na imagem.
 - 5- Começa pela base pelas partes menores seguindo as etapas descritas no manual.
 - 6- Montar o roupeiro deitado com a frente para baixo para facilitar o trabalho.
 - 7- As portas e gavetas serão instaladas por último.
 - 8- E por fim verifique se está tudo certo alinhado e fixado corretamente.
- Lembrando que o esquema de montagem varia entre os modelos de roupeiros.
 - É aconselhável pedir ajuda a outra pessoa para te auxiliar na hora de erguer o móvel.

WARDROBE ASSEMBLY INSTRUCTIONS

- 1- Start by preparing the space where the wardrobe will be assembled. Cover the floor so that it does not scratch the furniture.
 - 2- Have the necessary tools such as: screwdriver, screwdriver, etc.
 - 3- Open the boxes and check the parts as shown in the manual.
 - 4- Separate the parts as shown in the image.
 - 5- Start at the base with the smallest parts following the steps described in the manual.
 - 6- Assemble the wardrobe lying face down to make the work easier.
 - 7- The doors and drawers will be installed last.
 - 8- And finally check that everything is aligned and correctly fixed.
- Remember that the assembly scheme varies between wardrobe models.
 - It is advisable to ask another person to help you when lifting the furniture.







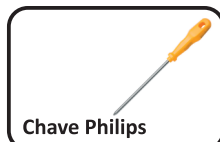



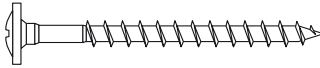
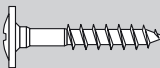



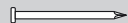
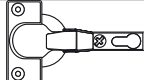

INSTRUCCIONES DE MONTAJE DEL ARMARIO

- 1- Prepare el espacio donde se montará el armario. Cubra el suelo para que no raye el mueble.
 - 2- Dispóngase de las herramientas necesarias, como destornillador, destornillador, etc.
 - 3- Abra las cajas y revise las piezas como se indica en el manual.
 - 4- Separe las piezas como se muestra en la imagen.
 - 5- Comience por la base con las piezas más pequeñas siguiendo los pasos descritos en el manual.
 - 6- Monte el armario boca abajo para facilitar el trabajo.
 - 7- Las puertas y los cajones se instalarán en último lugar.
 - 8- Por último, compruebe que todo esté alineado y correctamente fijado.
- Recuerde que el esquema de montaje varía según el modelo de armario.
 - Se recomienda pedir ayuda a otra persona para levantar el mueble.

MATERIAL PARA MONTAGEM | ASSEMBLY MATERIAL | MATERIAL PARA ARMADO

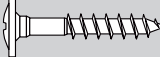

FERRAGEM | HARDWARE | HERRAJES

A	PARAFUSO FLANGEADO 4x40 FLANGE SCREW 4x40 TORNILLO FLANGEADO 4x40		32
B	PARAFUSO FLANGEADO 3,5x22 FLANGE SCREW 3,5x22 TORNILLO FLANGEADO 3,5x22		08
C	PARAFUSO 3,5x12 SCREW 3,5x12 TORNILLO 3,5x12		110
D	PARAFUSO 3,5x16 SCREW 3,5x16 TORNILLO 3,5x16		08
E	FIXADOR FIXER FIJADOR		10
F	CANTONEIRA 18x18 15x15 CORNER ESQUINA 15x15		10
G	CAVILHA 6x30 6x30 PEGS TACOS 6x30		08
H	PREGO 10x10 C/C NAIL 10x10 CLAVO 10x10		100
I	DOBRADIÇA HINGE BISAGRA		16
J	CALÇO DOBRADIÇA HINGE MOUNTING PLATE BASE DE BISAGRA		16
K	SUPORE CABIDEIRO HANGER SUPPORT APOYO PERCHERO		02
L	PREGO 13x15 C/C NAIL 13x15 CLAVO 10x10		08
M	DISTANCIADOR CORREDIÇA SLIDE DISTANCER DISTANCIADOR DE CORREDIZA		08
N	SAPATA SHOE ZAPATA		08
O	SUPORE PRATELEIRA SHELF SUPPORT SOPORTE ESTANTE		28
P	COLA GLUES PEGAMENTO		01
Q	CABIDEIRO HANGER PERCHERO		01
R	PUXADOR HANDLE TIRADOR		04
S	CORREDIÇA SLIDER CORREDIZA		04
T	PARAFUSO 3,5x25 FLANGEADO (RIPADO) 3,5x25 FLANGE SCREW (SLATTED) TORNILLO 3,5x25 FLANGEADO (RANURADO)		24



UTILIZE A RÉGUA PARA A MEDIÇÃO DOS PARAFUSOS | USE THE RULER TO MEASURE THE SCREWS | USA LA REGLA PARA MEDIR LOS TORNILLOS

LISTA DE PEÇAS | PARTS LIST | LISTA DE PIEZAS

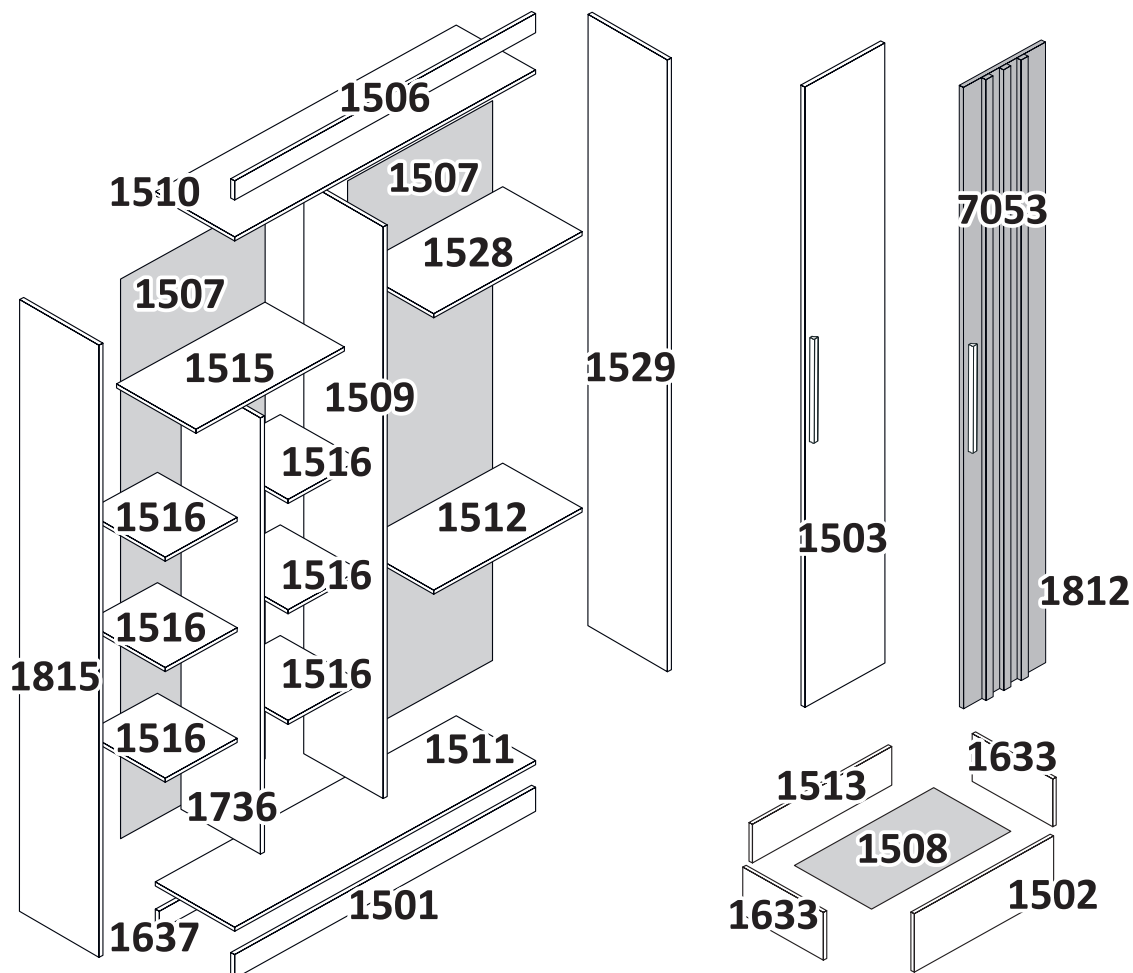

CÓDIGO CODE CODIGO	DESCRIÇÃO DESCRIPTION DESCRIPCIÓN	QTD. QUANTITY CANTIDAD	DIMENSÕES DIMENSIONS DIMENSIONES		
			COMP. LENGTH LONGITUD	LARG. WIDTH ANCHO	CHAPA PLATE LÁMINA
1501	RODAPÉ FRONTAL FRONT BASEBOARD ZÓCALO DIANTERO	01	1,332	0,150	12mm
1502	FRENTE GAVETA FRONT DRAWER FRENTE CAJÓN	02	0,599	0,160	12mm
1503	PORTA DOOR PUERTA	04	1,915	0,333	15mm
1512	TAMPO MEIO HALF TOP TAPA MEDIO	01	0,660	0,430	12mm
1529	LATERAL DIREITA RIGHT SIDE LATERAL DERECHA	01	2,170	0,430	12mm
1815	LATERAL ESQUERDA LEFT SIDE LATERAL IZQUIERDA	01	2,170	0,430	12mm
1506	RODA FORRO RODAFORRO / RODAFORRO	01	1,350	0,105	12mm
1510	TAMPO SUPERIOR UPPER TOP TAPA SUPERIOR	01	1,332	0,430	12mm
1513	TRASEIRO GAVETA DRAWER BACK / TRASERO CAJÓN	02	0,070	0,547	12mm
1509	DIVISÓRIA DIREITA/CENTRAL CENTRAL/RIGHT DIVISION DIVISIÓN DERECHA/CENTRAL	01	1,896	0,430	12mm
1508	FUNDO GAVETA DRAWER BOTTOM FONDO CAJÓN	02	0,327	0,570	3mm
1736	DIVISÓRIA COLMÉIA BEEHIVE DIVISION DIVISIÓN COLMENA	01	1,550	0,360	12mm
1516	PRATELEIRA COLMÉIA BEEHIVE SHELV ESTANTE COLMENA	06	0,324	0,360	12mm
1515	PRATELEIRA FIXA FIXED SHELF ESTANTE FIJA	01	0,660	0,360	12mm
1633	LATERAL GAVETA DRAWER SIDE LATERAL CAJÓN	04	0,320	0,085	12mm
1528	PRATELEIRA MÓVEL MOVABLE SHELF ESTANTE MÓVEL	01	0,660	0,360	12mm
1637	RODAPÉ TRASEIRO BACK BASEBOARD ZÓCALO TRASERO	01	1,332	0,150	12mm
1511	TAMPO INFERIOR BOTTOM TOP TAPA INFERIOR	01	1,332	0,430	12mm
1507	COSTAS BACK TRASERA	02	1,920	0,675	3mm
7053	RIPADO SLATTED / RANURADO	06	1,195	0,025	12mm
1812	PORTA RIPADO SLATTED DOOR / PUERTA RANURADO	02			

Preparando a Lateral Esquerda.

Preparing Left Side.

Preparante Lateral Izquierda.

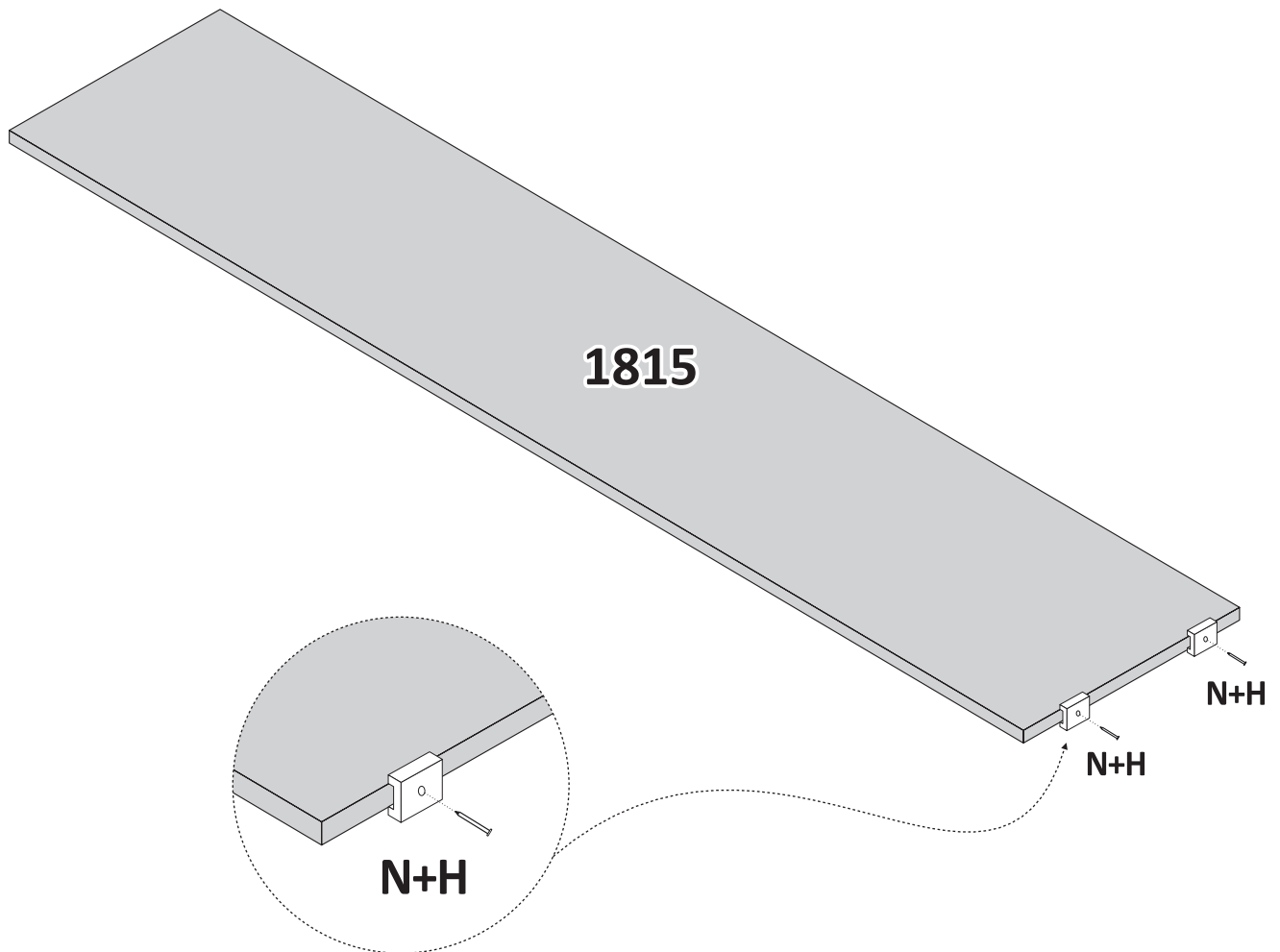

COLOCAÇÃO DAS SAPATAS.

putting on the shoes.
poniéndose los zapatos.

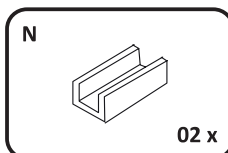
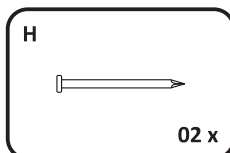

Preparando a Lateral Direita.

Preparing Right Side.

Preparante Lateral Derecha.

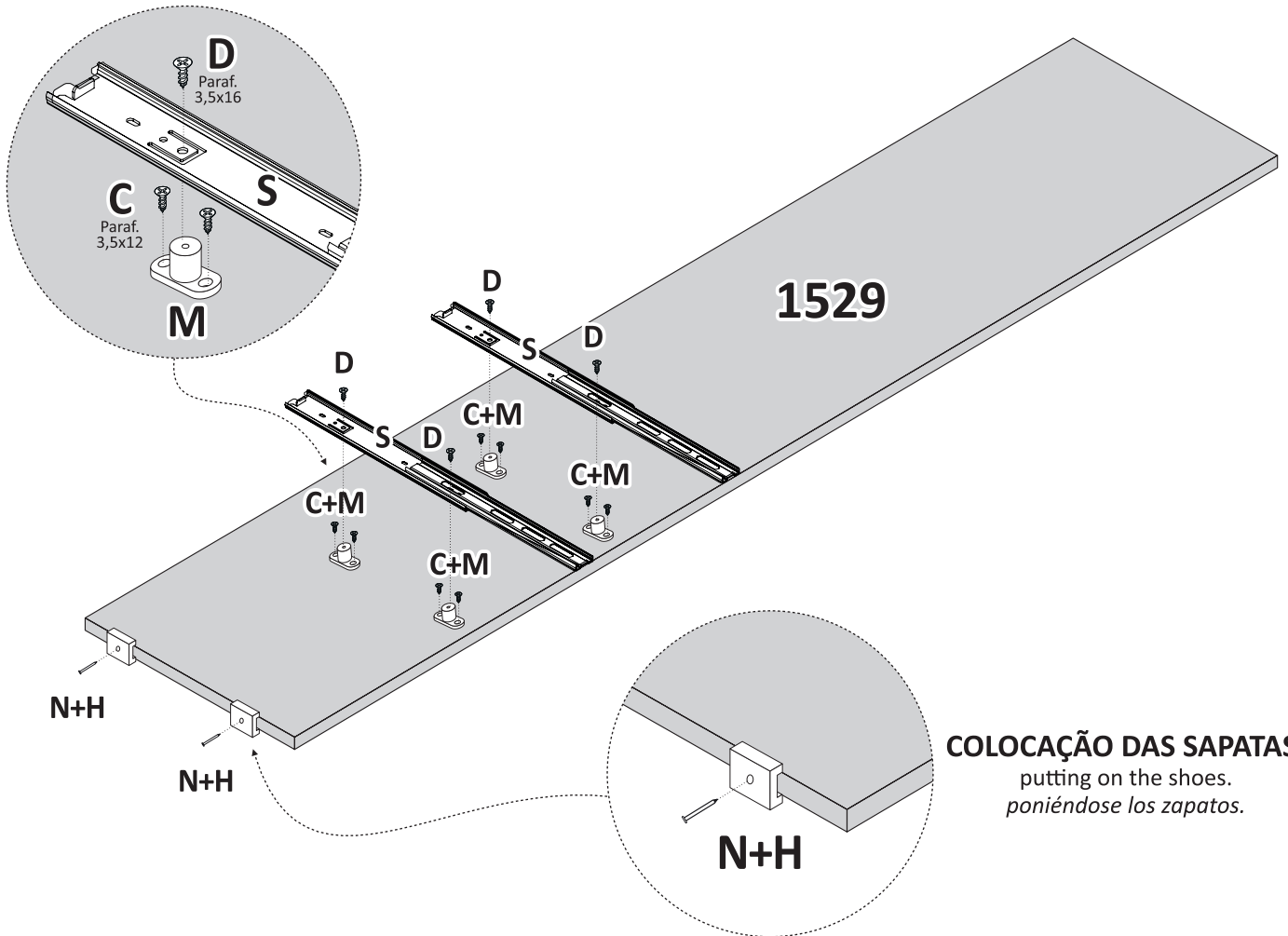

COLOCAÇÃO DAS SAPATAS.

putting on the shoes.
poniéndose los zapatos.

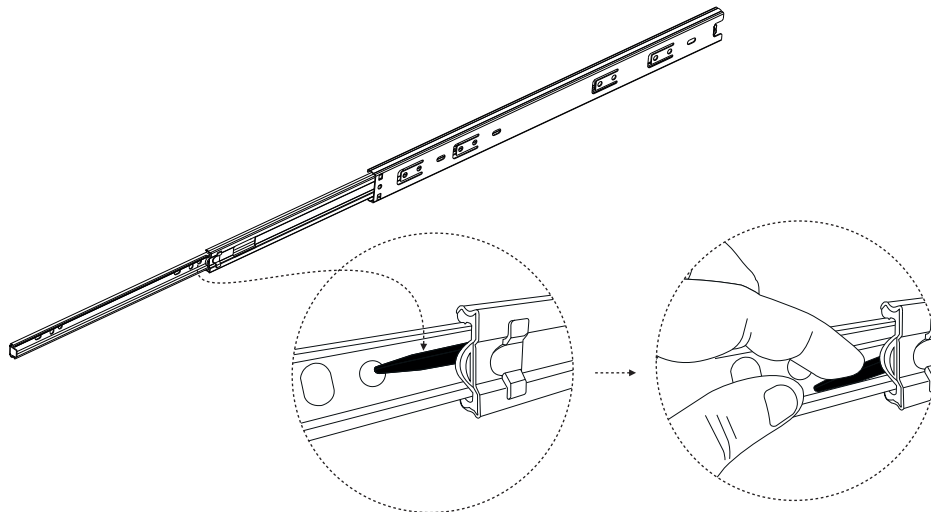

ABAIXE A TRAVA PRETA E RETIRE A PEÇA CONFORME DESENHO ABAIXO.

LOWER THE BLACK LATCH AND REMOVE THE PART AS SHOWN IN THE DRAWING BELOW.

BAJE EL SEGURO NEGRO Y RETIRE LA PIEZA SEGÚN EL DIBUJO DE ABAJO.

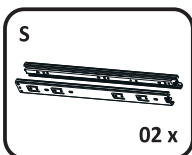
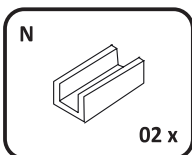
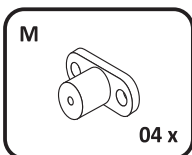
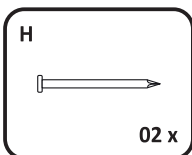
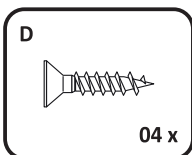
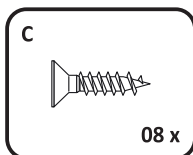

Preparando Rodapé.

Preparing Baseboard.

Preparante Zócalo.

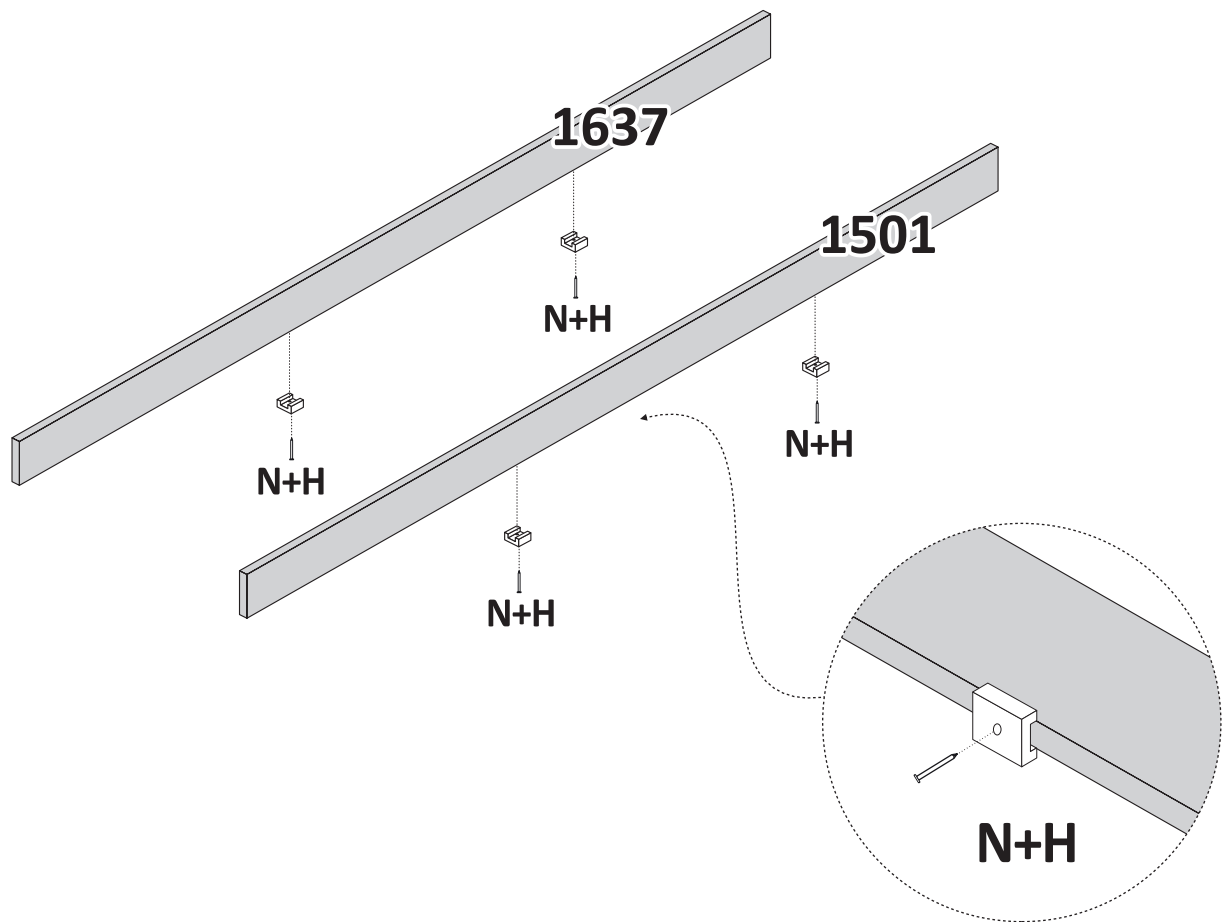

COLOCAÇÃO DAS SAPATAS.

putting on the shoes.
poniéndose los zapatos.

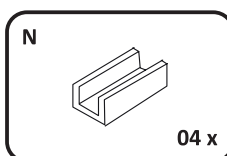
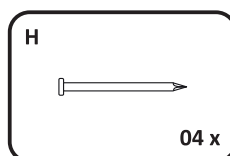

Montar Rodapé.

Assembly Baseboard.

Montaje Zócalo.

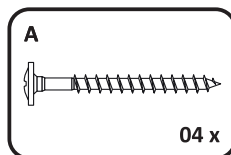
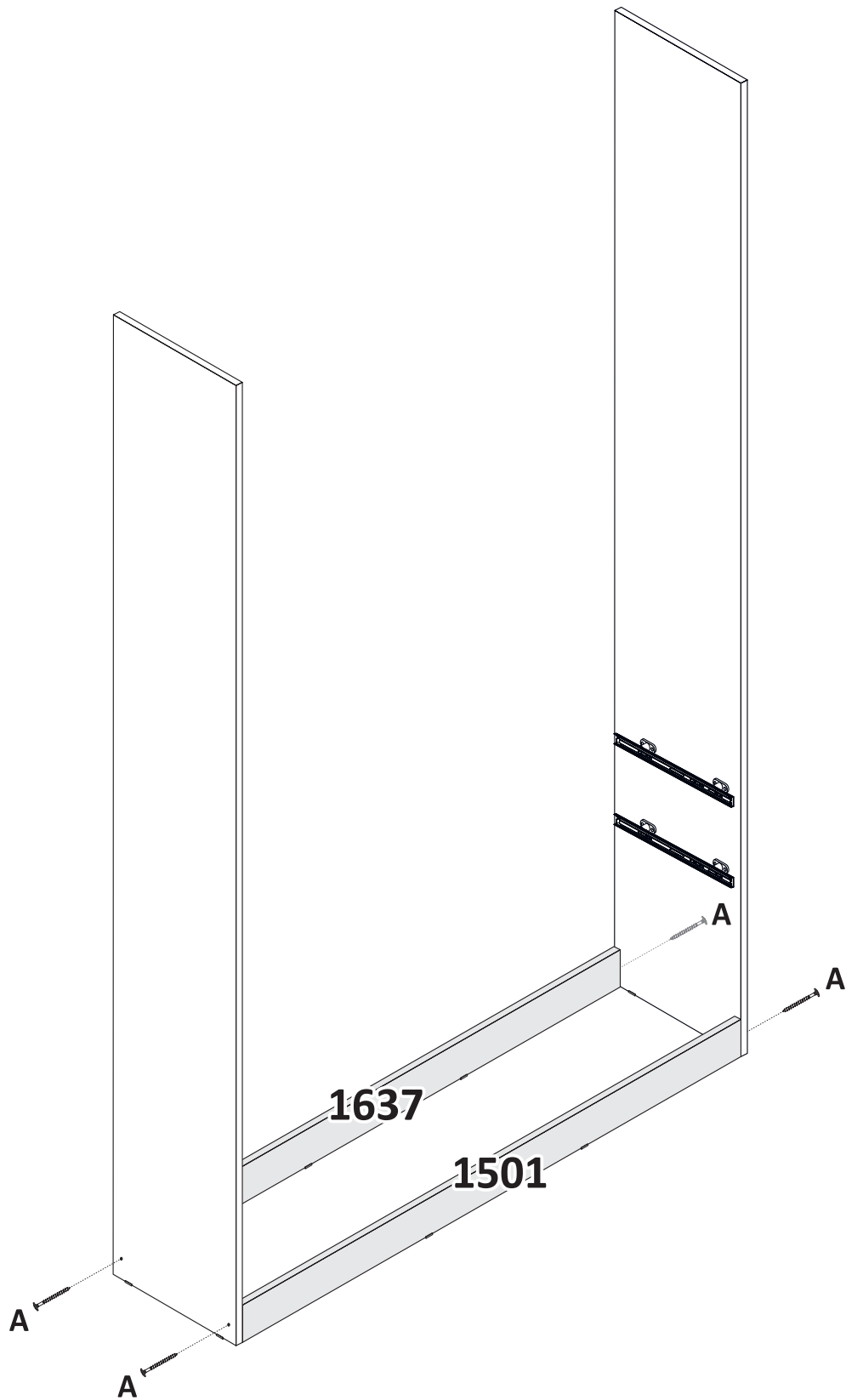

Montar Tampo Inferior.

Assembly Bottom Top.
Montaje Tapa Inferior.

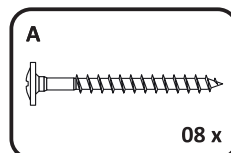
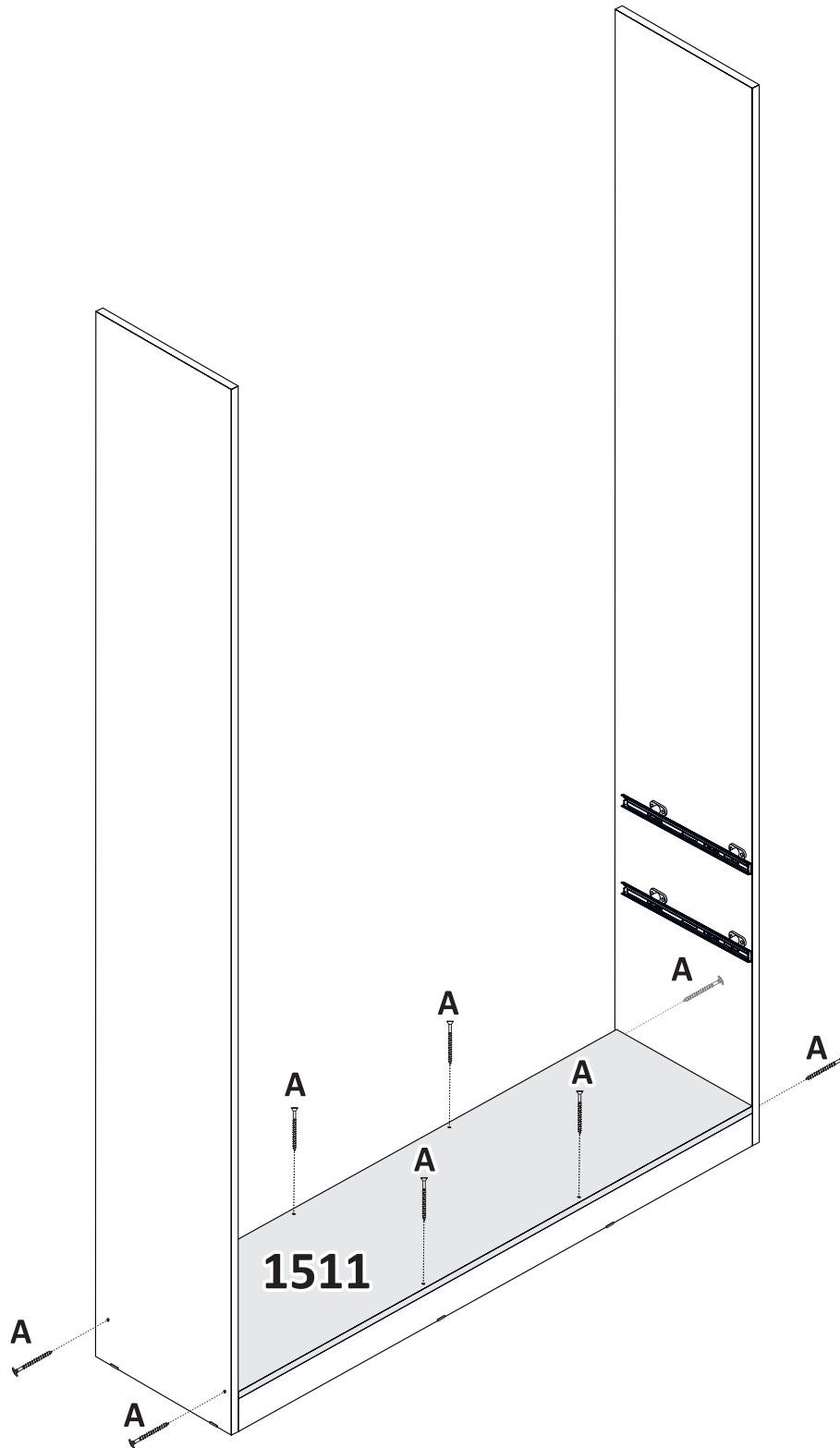

Preparando a Divisão Central.

Preparing the Central Divider.

Preparando el División Central.

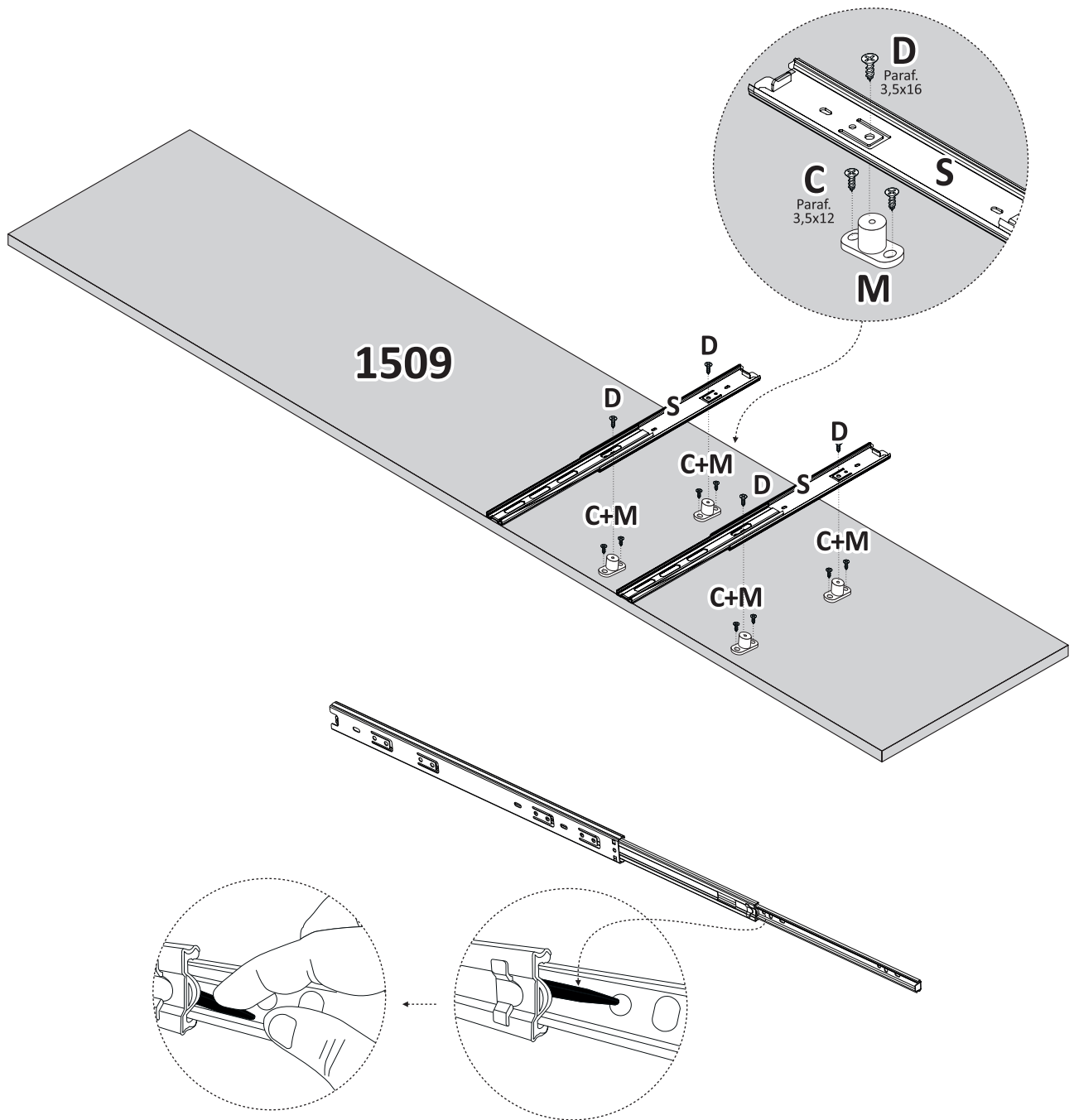

ABAIXE A TRAVA PRETA E RETIRE A PEÇA CONFORME DESENHO ABAIXO.
LOWER THE BLACK LATCH AND REMOVE THE PART AS SHOWN IN THE DRAWING BELOW.
BAJE EL SEGURO NEGRO Y RETIRE LA PIEZA SEGÚN EL DIBUJO DE ABAJO.

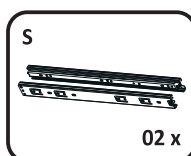
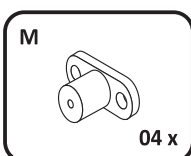
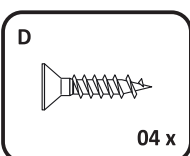
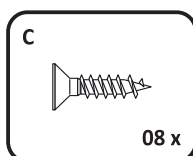

Montar as Divisões.

Assembly Divider.
Montaje División.

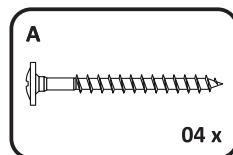
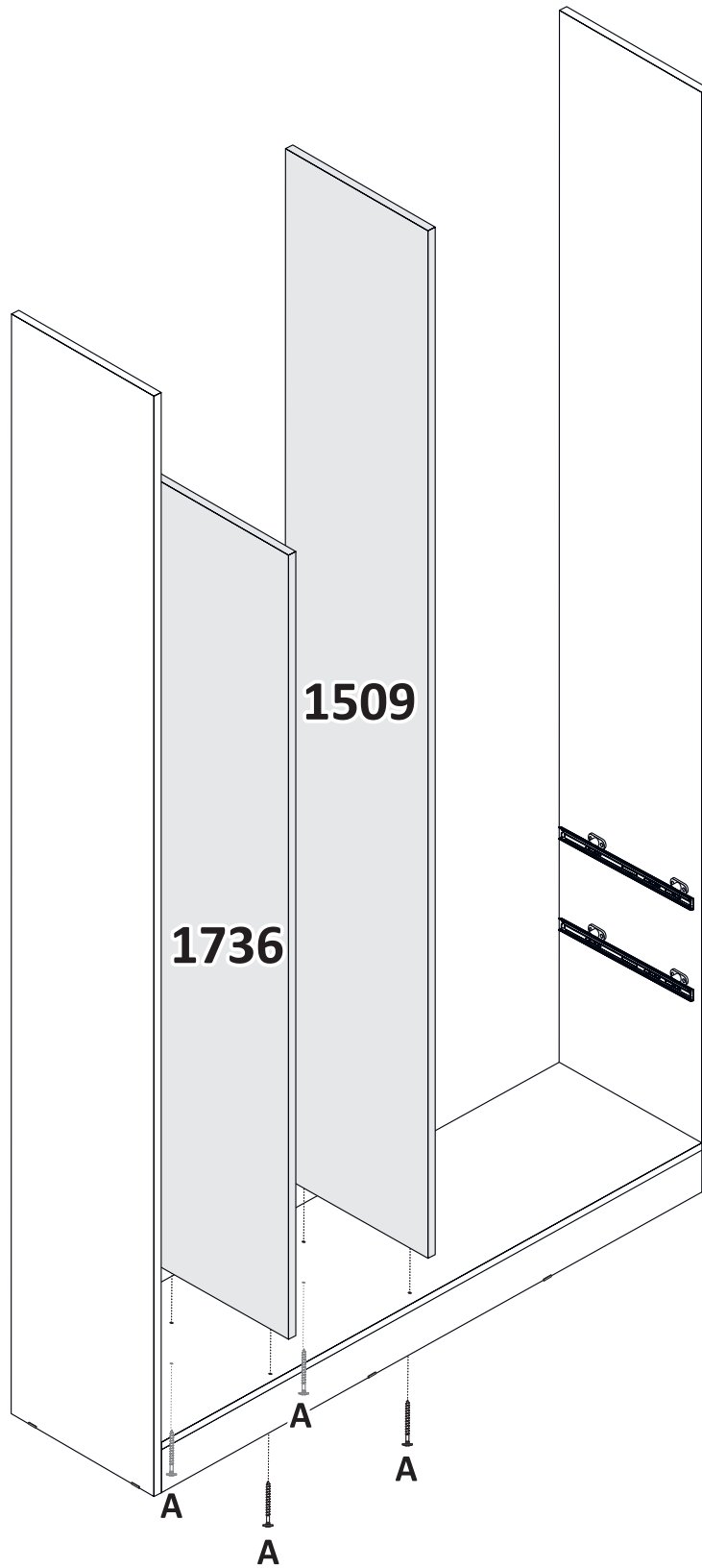

Parafusar as Prateleiras Fixas.

Assembly Fixed Shelves.
Montaje Estantes Fijas.

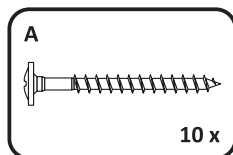
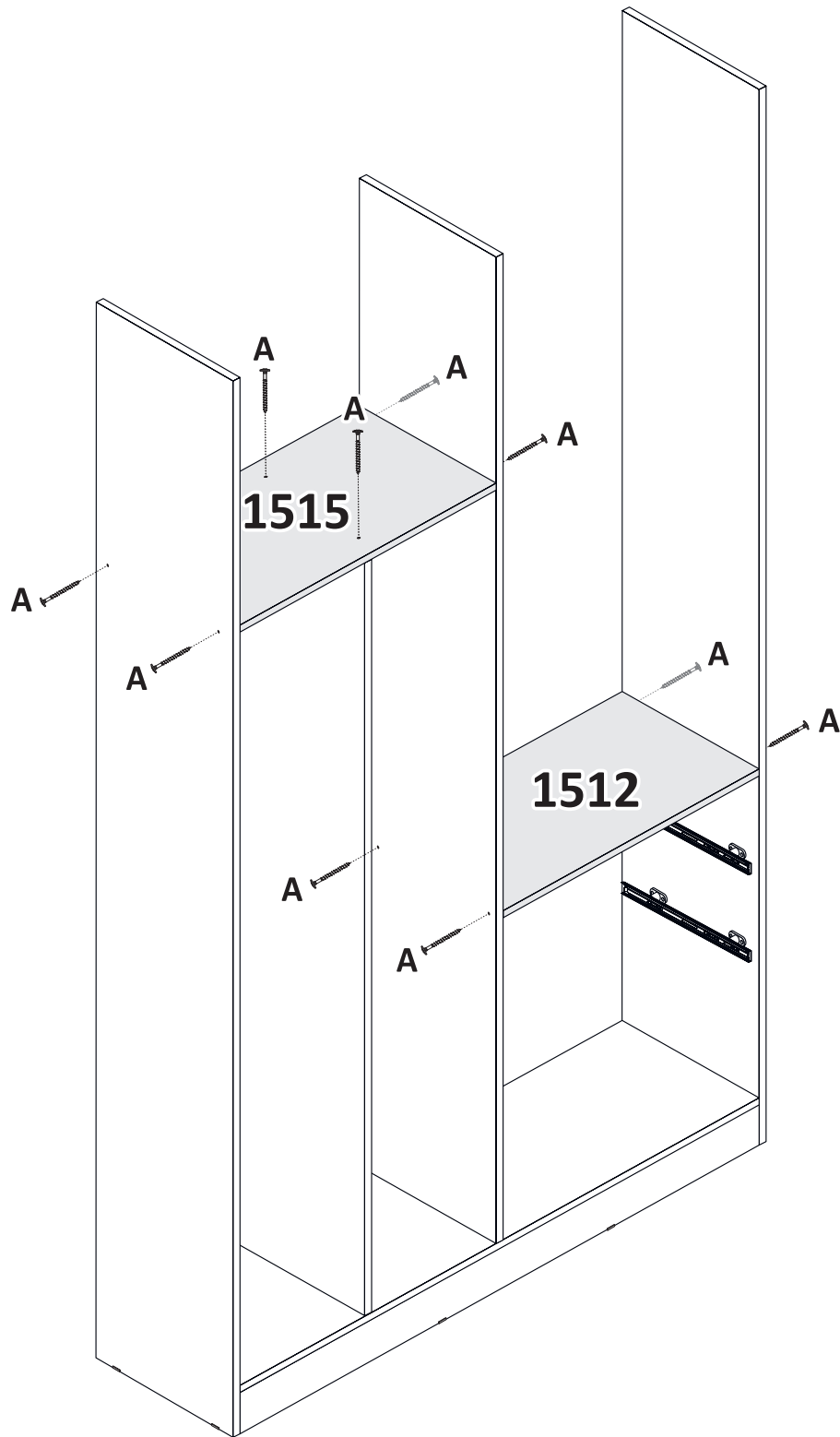

Montagem Tampo.

Hive Top.
Estante Tapa.

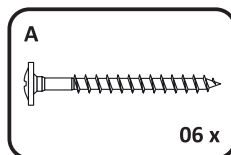
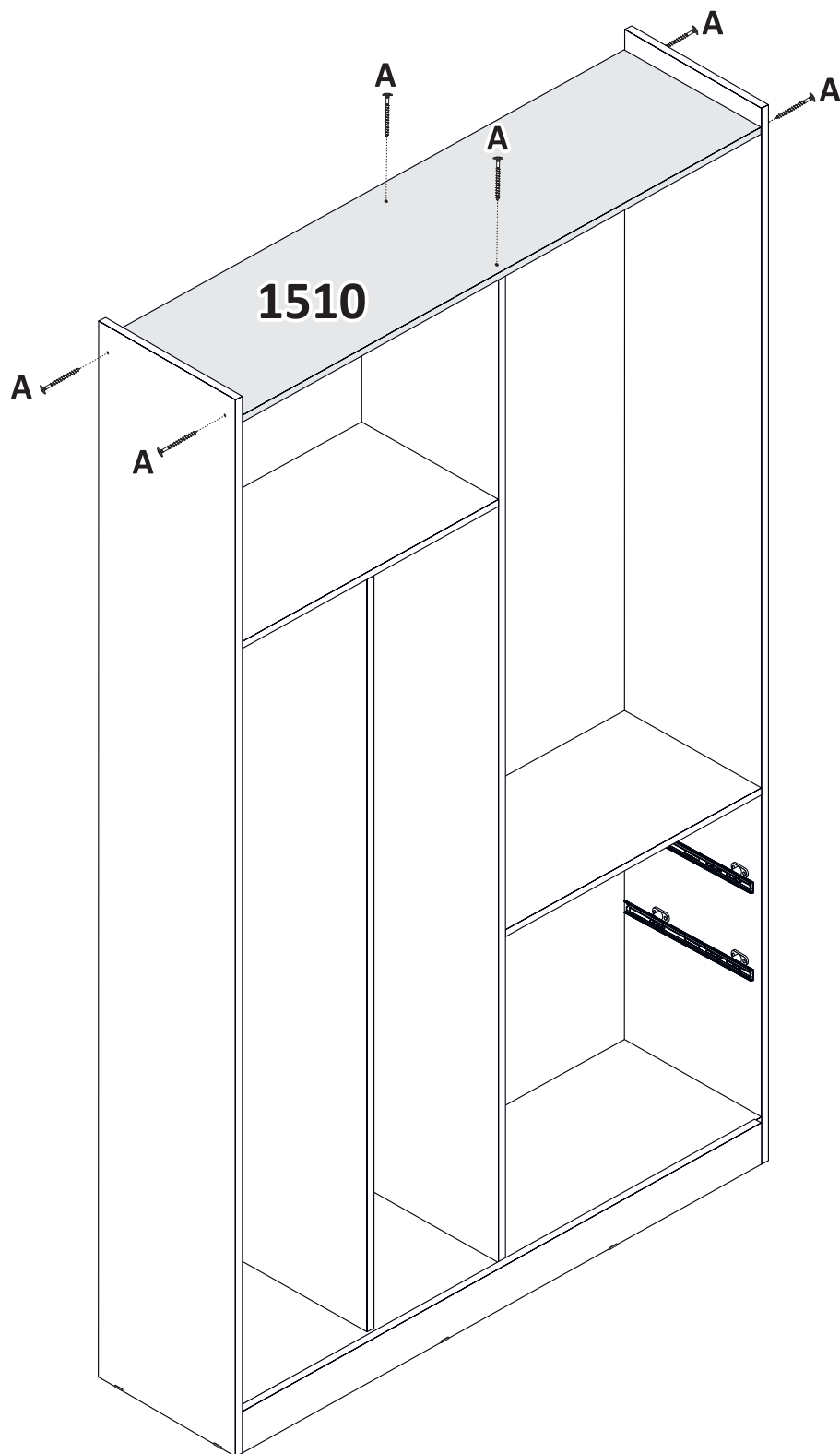

Montagem Rodaforro.

Assembly Rodaforro.
Montaje de Rodaforro.

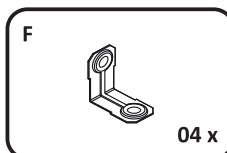
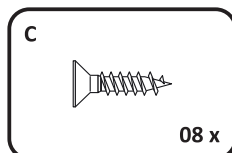
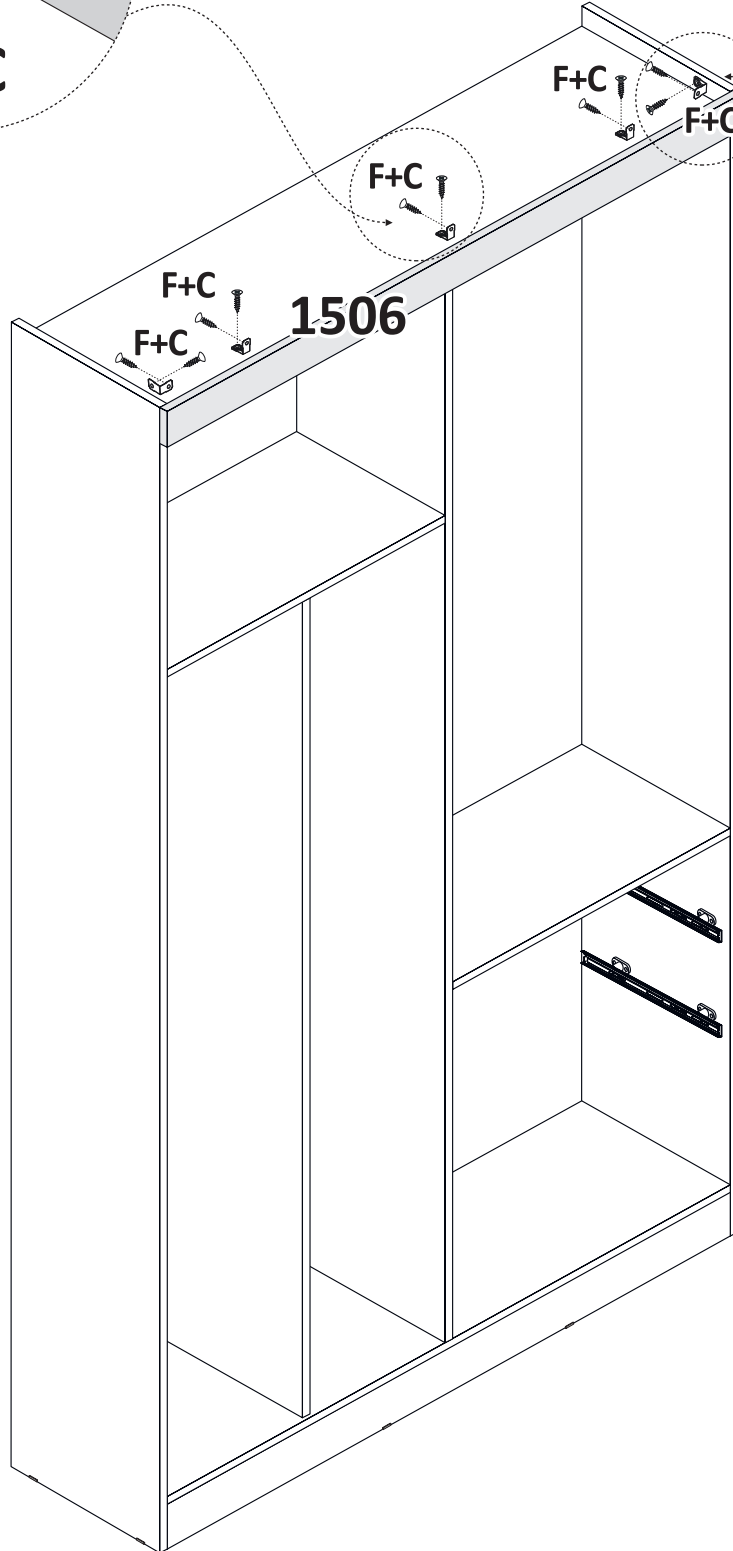
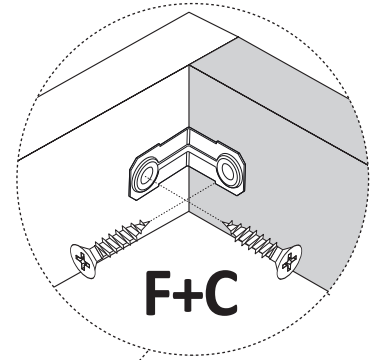
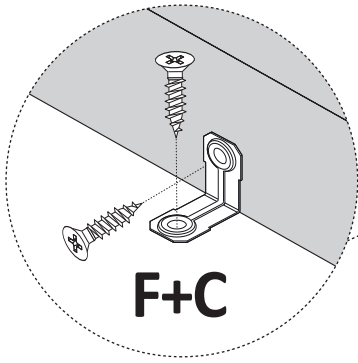

Montagem das Costas.

Back Assembly.
Montaje Trasero.

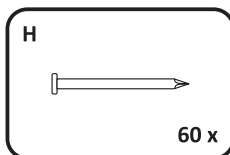
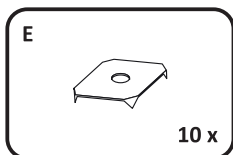
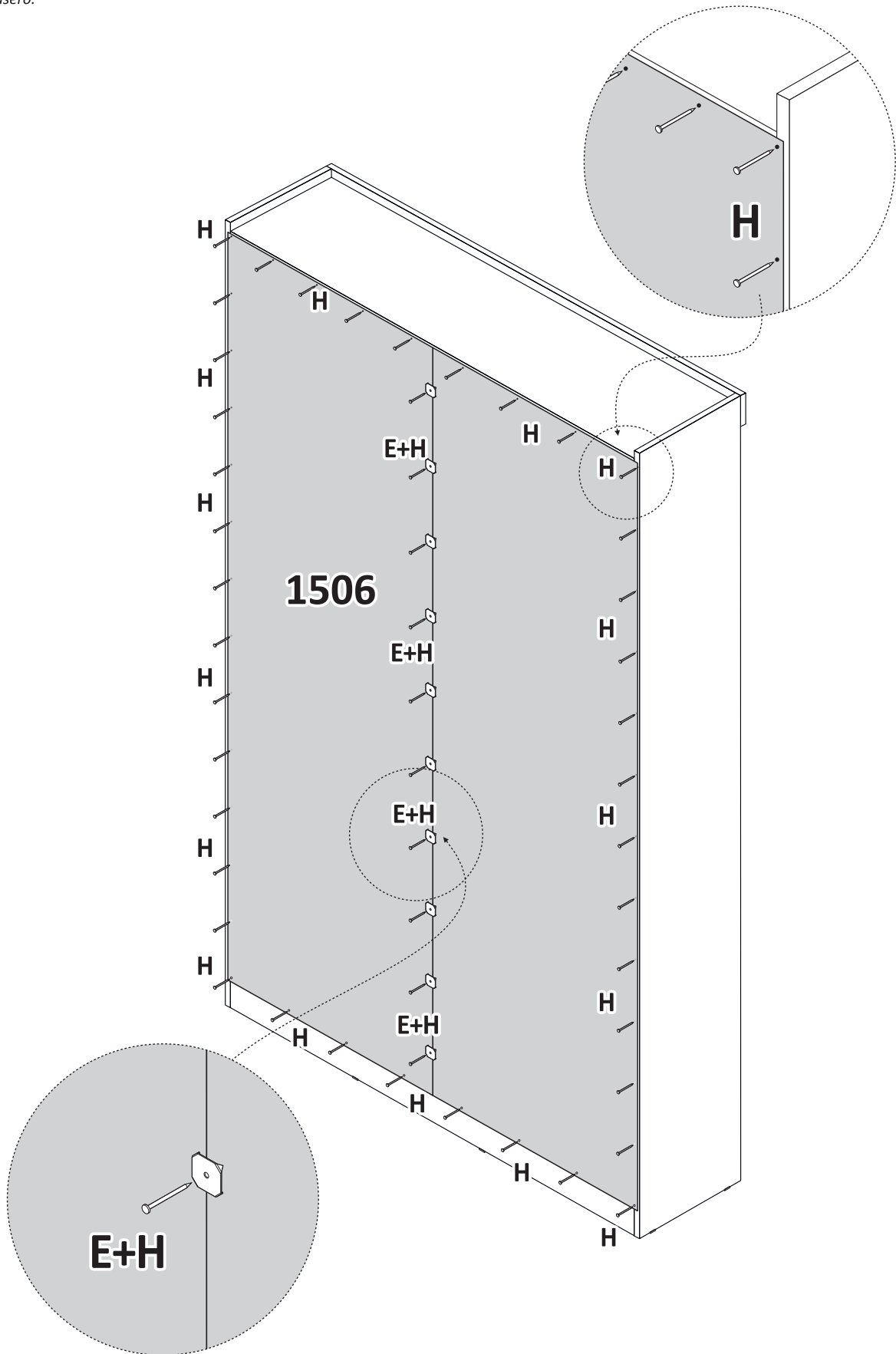

Montagem das Prateleiras Móveis.

Assembly Movable Shelves.

Montaje de Estantes Móveles.

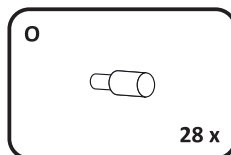
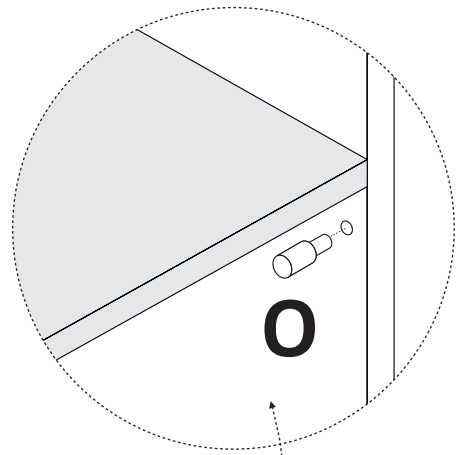
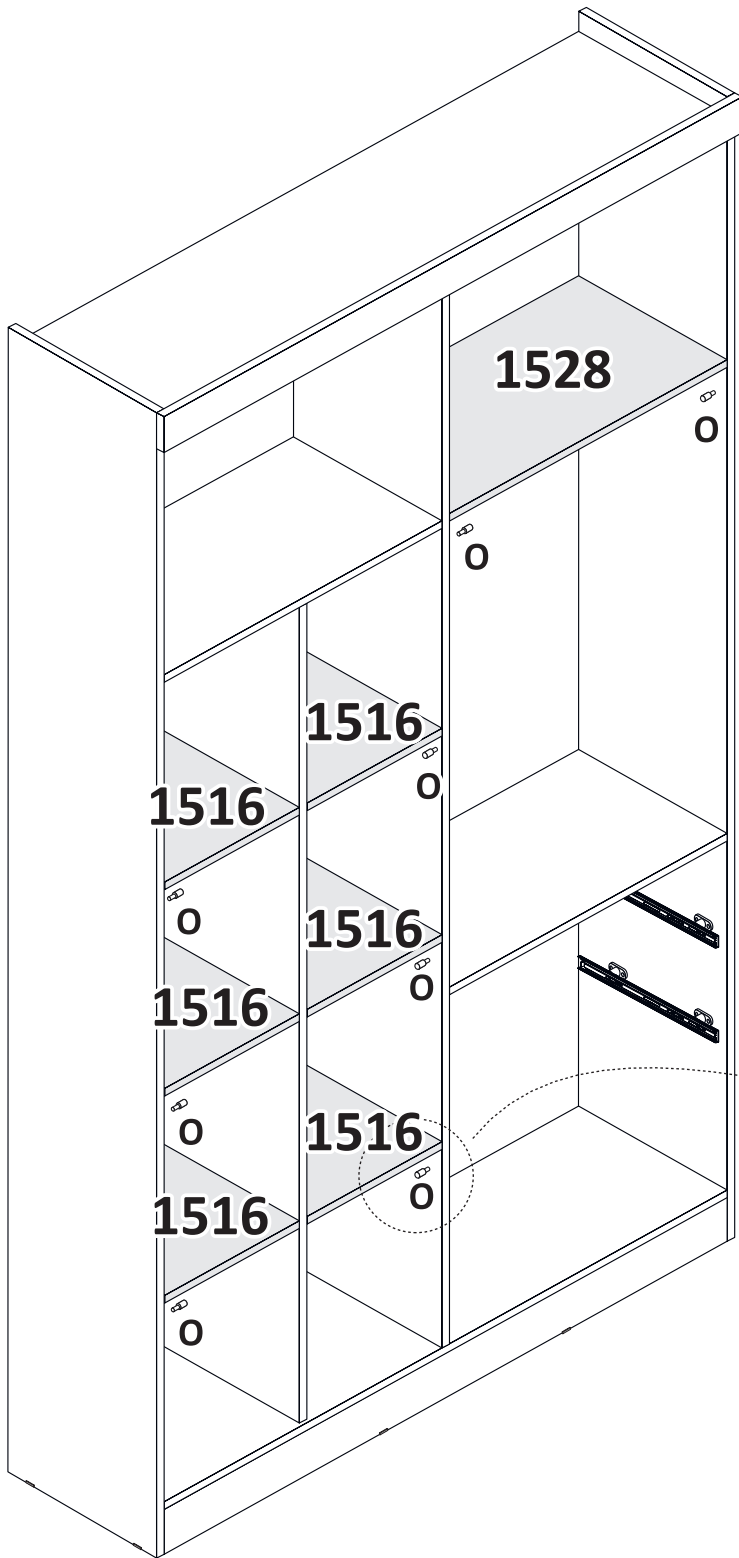

Montagem do Cabideiro.

Assembly Hanger.

Montaje de Perchero.

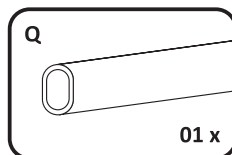
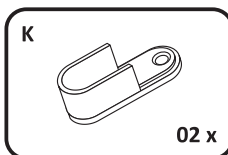
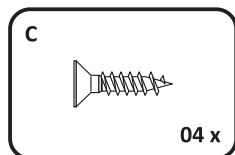
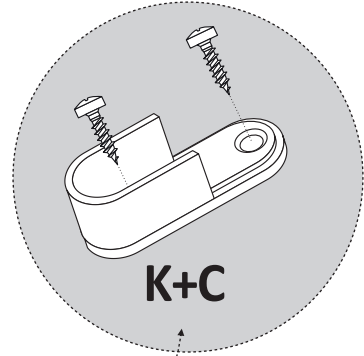
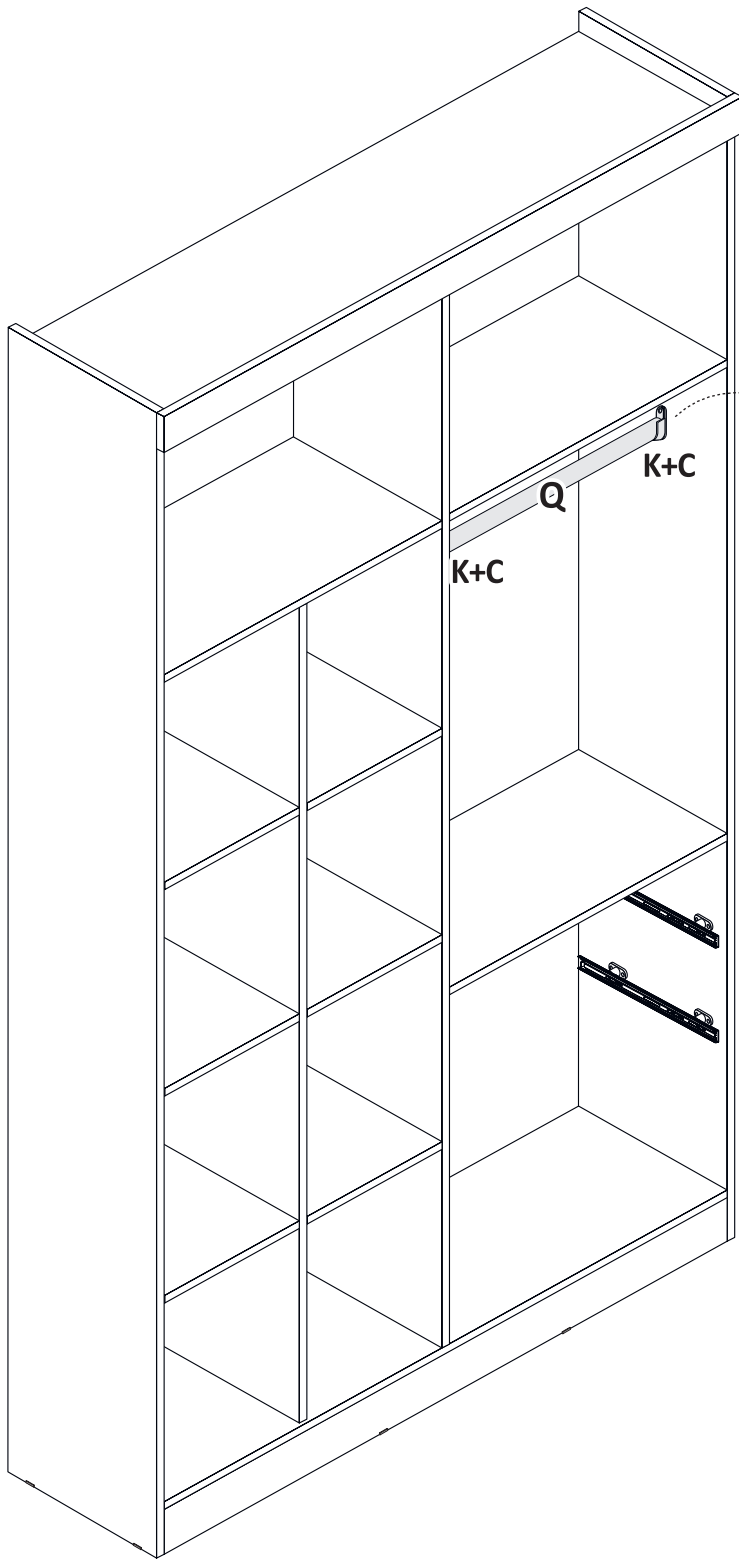

Peso suportado em cada parte.

Weight supported on each part.

Peso soportado en cada parte.

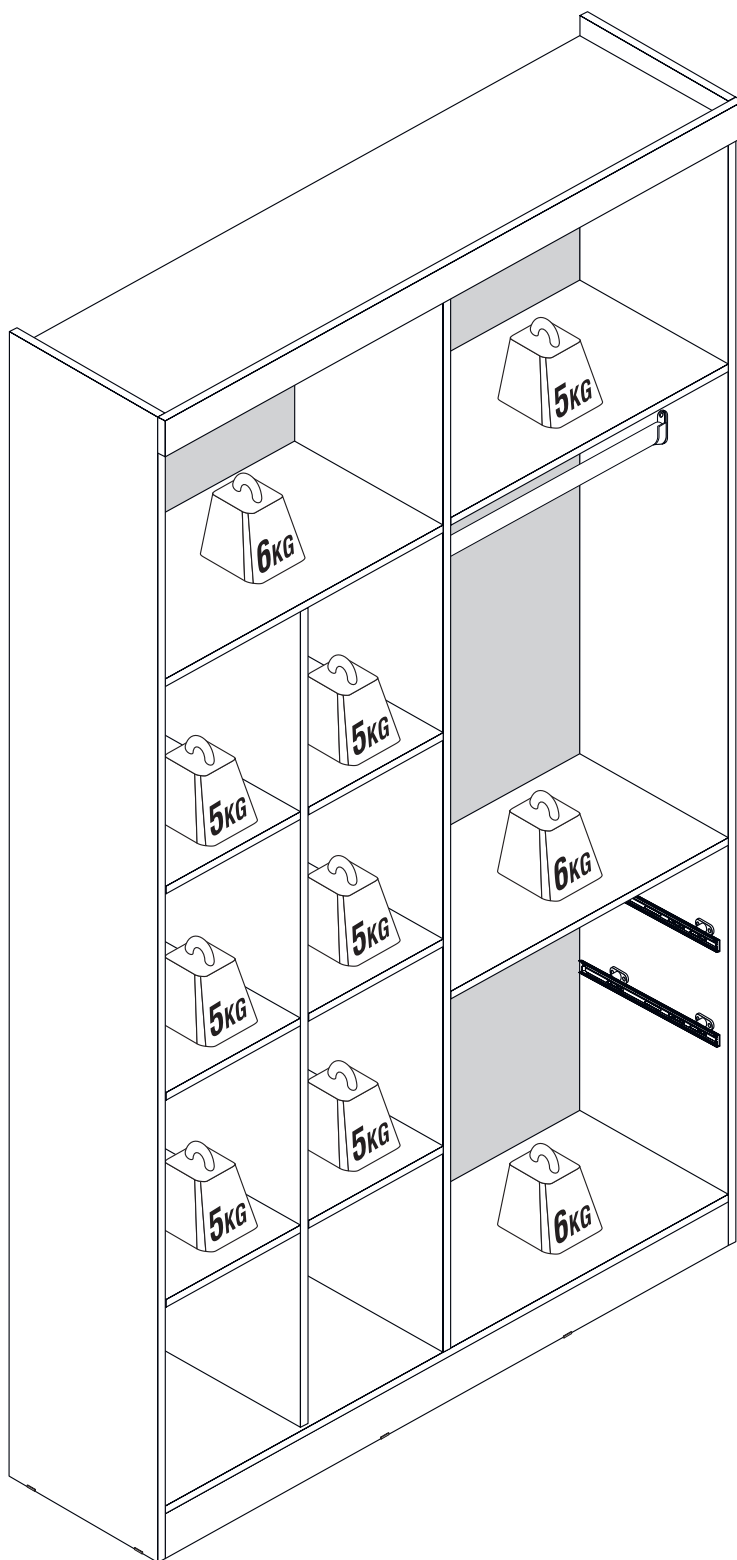

Medidas espaços internos.

Internal spaces measurements.

Medidas del espacios interiores.

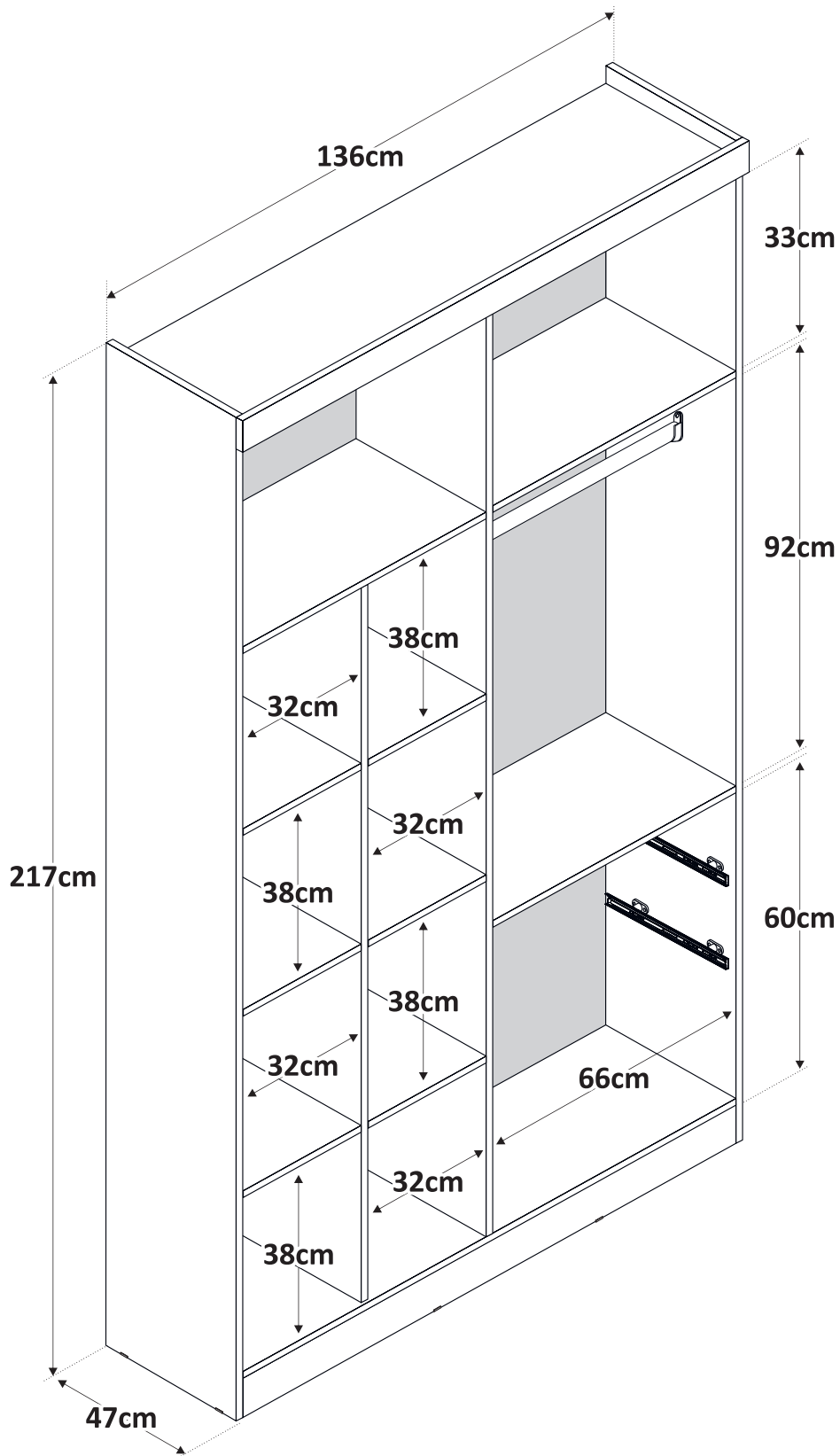

Montagem Porta Esquerda Grande.

Big Left Side Door Assembly.

Montaje de la Puerta Lateral Izquierda Grande.

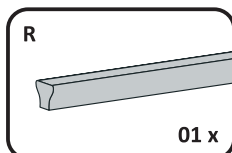
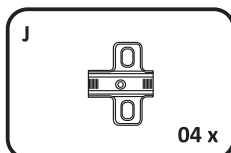
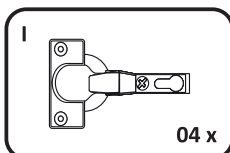
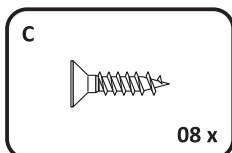
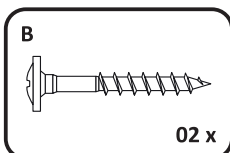
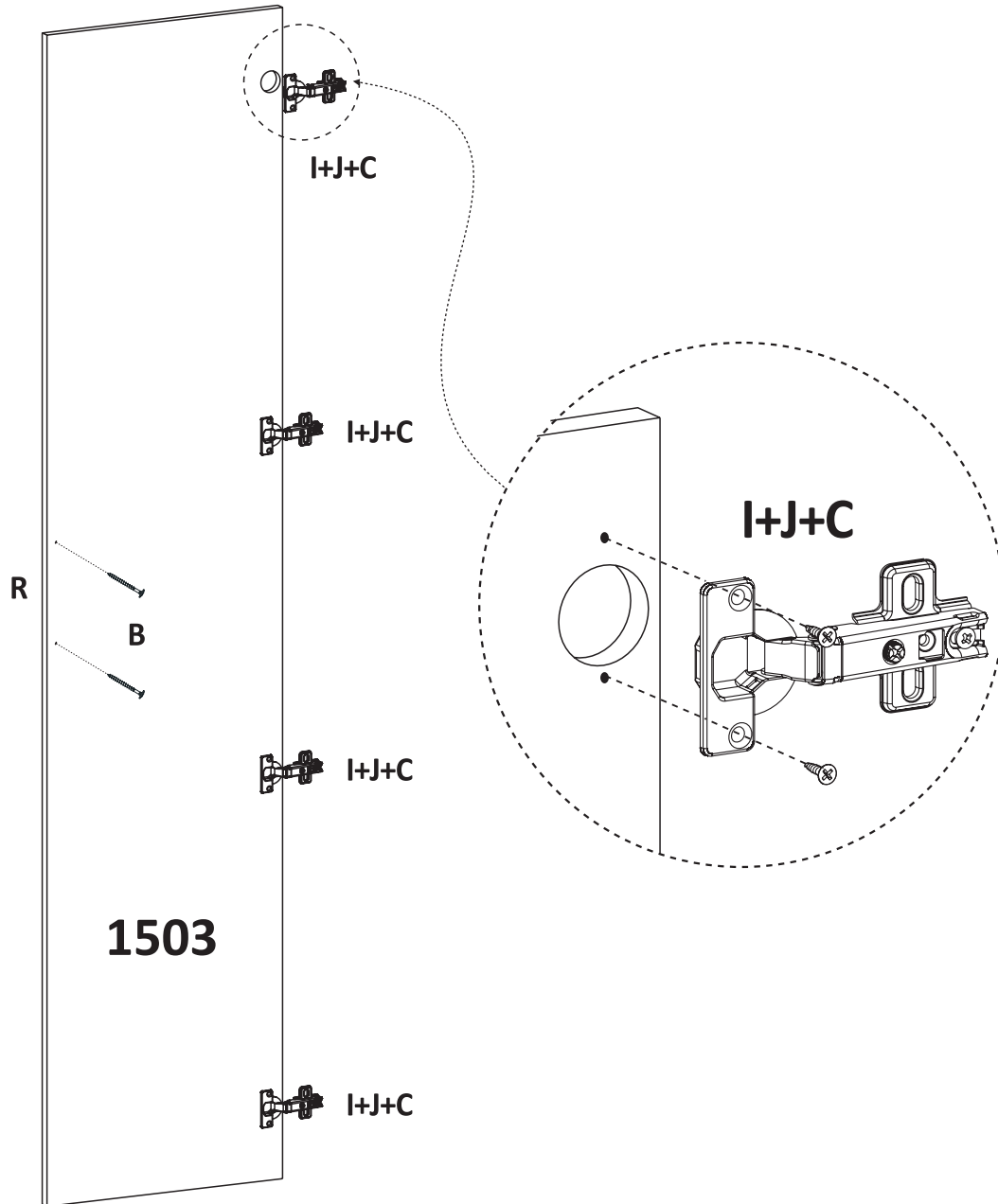

Montagem Porta Direita Grande.

Big Right Side Door Assembly.

Montaje de la Puerta Lateral Derecha Grande.

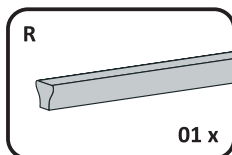
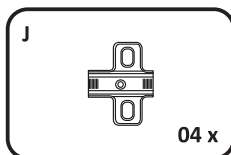
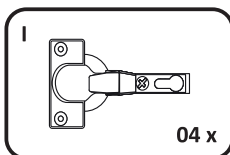
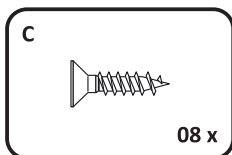
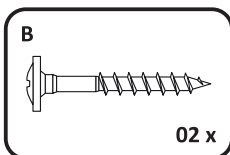
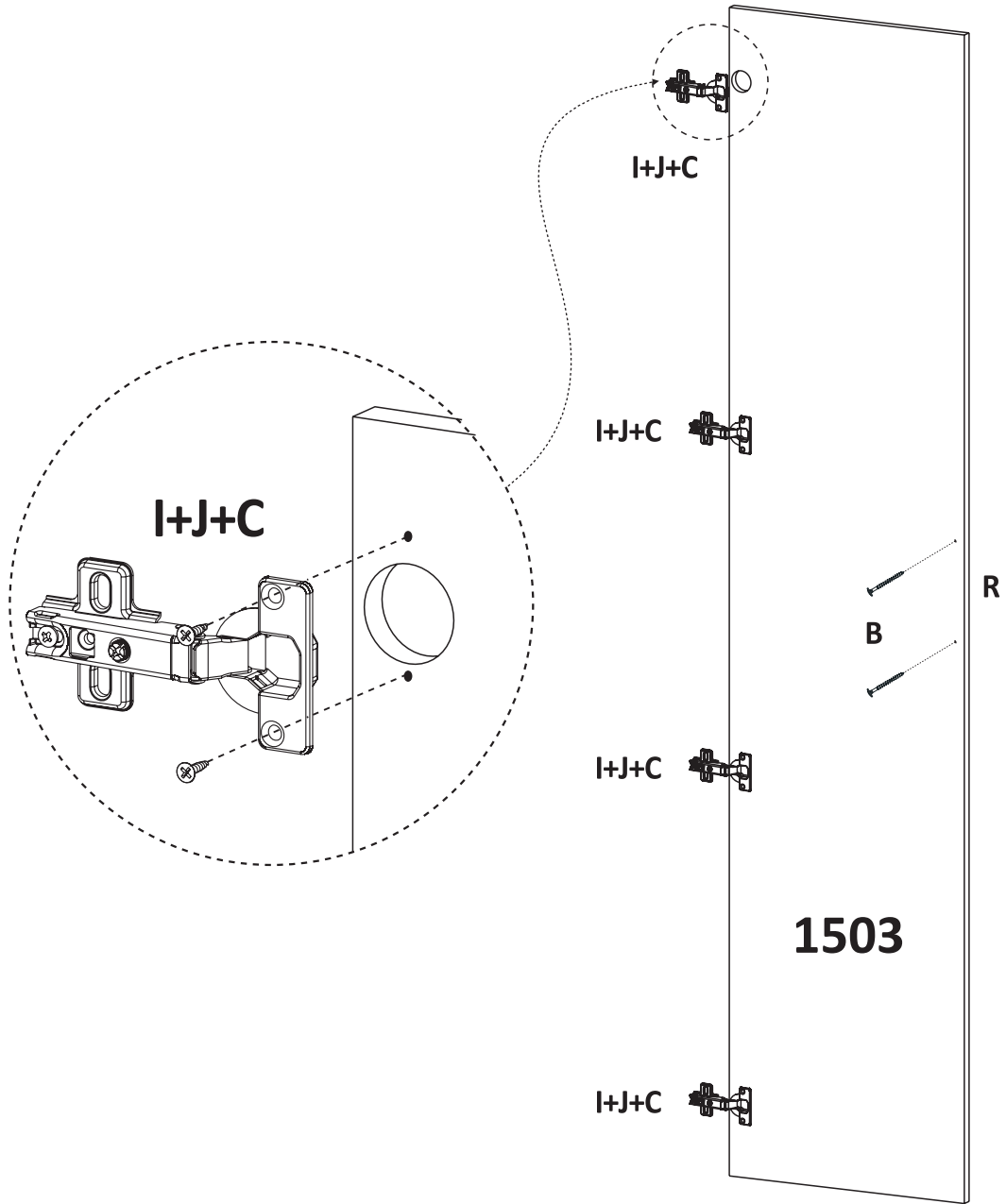

Montagem do Ripado.

Assembly Slatted.

Montaje de Ranurado.



**NÃO UTILIZAR
PARAFUSADEIRA**
DO NOT USE A SCREWDRIVER
No utilice un destornillador

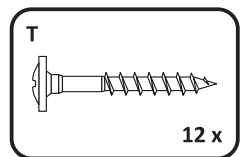
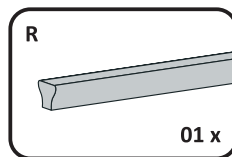
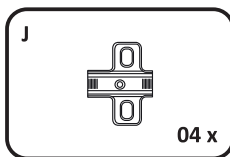
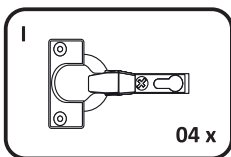
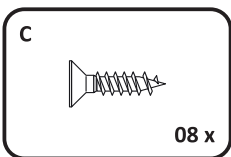
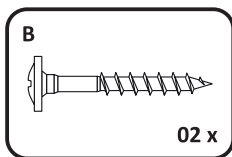
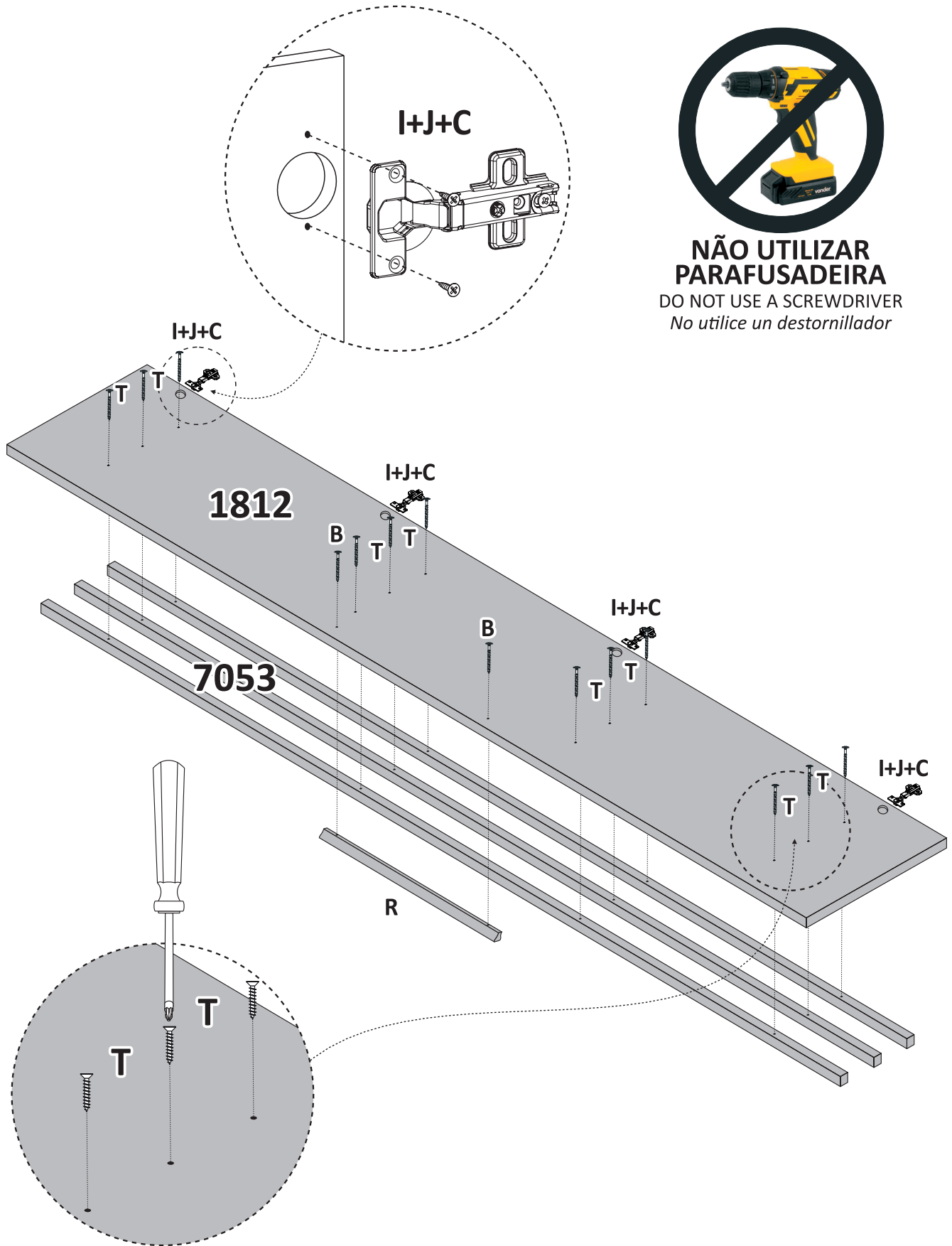

Coloção das Portas.

Door Placement.

Colocación de Puertas.

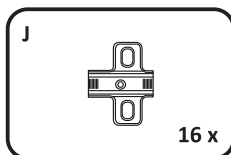
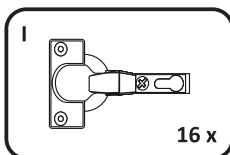
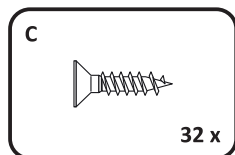
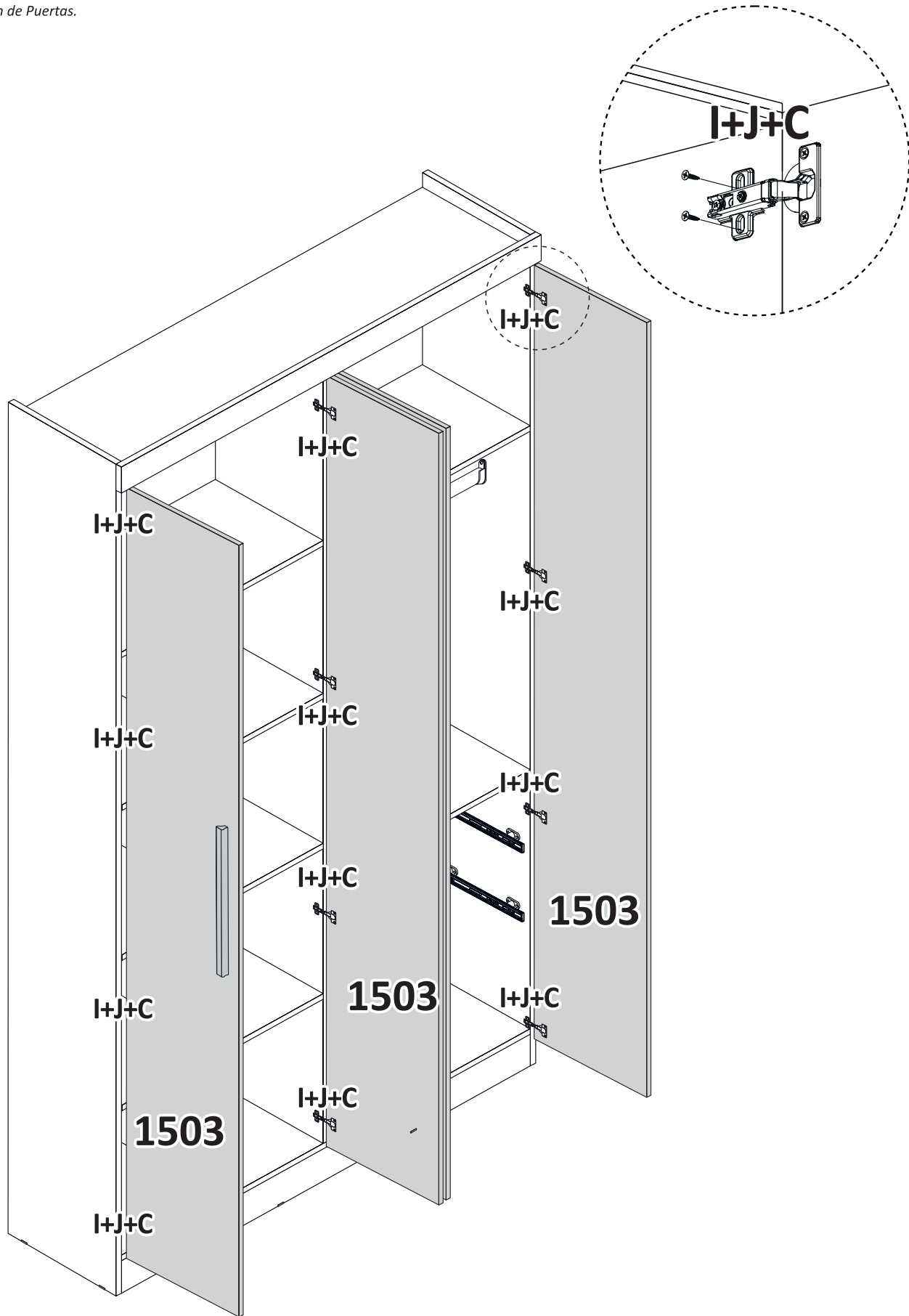

Montagem das Gavetas.

Assembling the Drawers.
Montaje de Cajones.

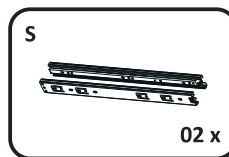
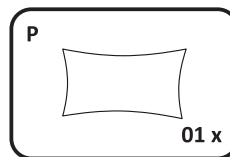
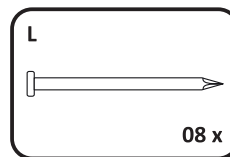
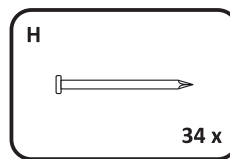
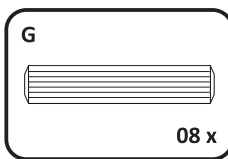
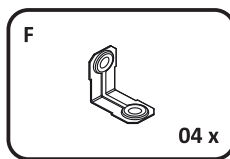
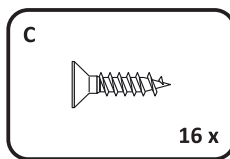
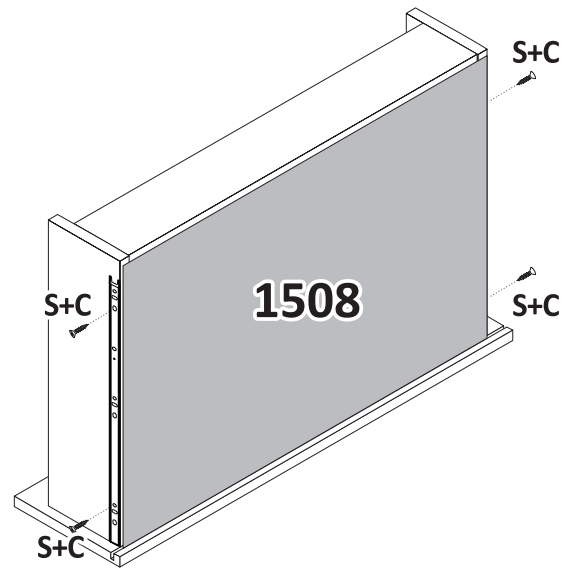
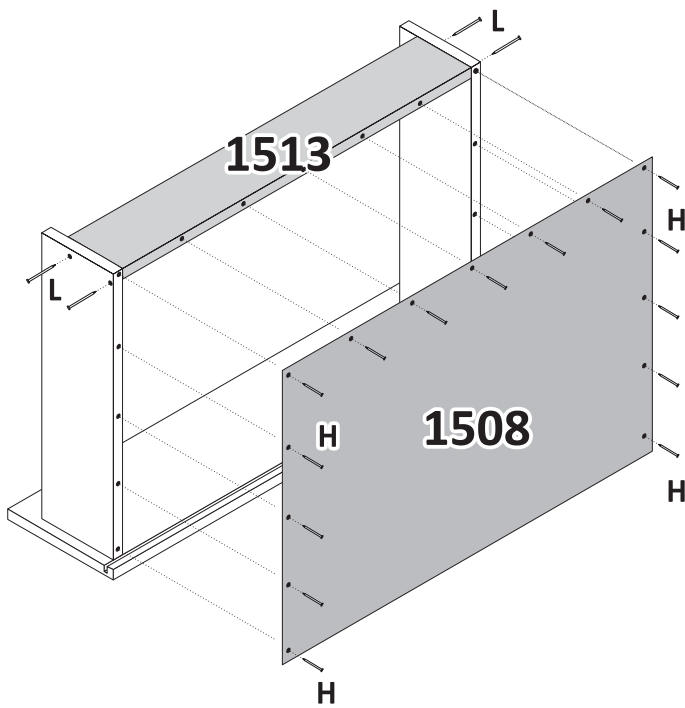
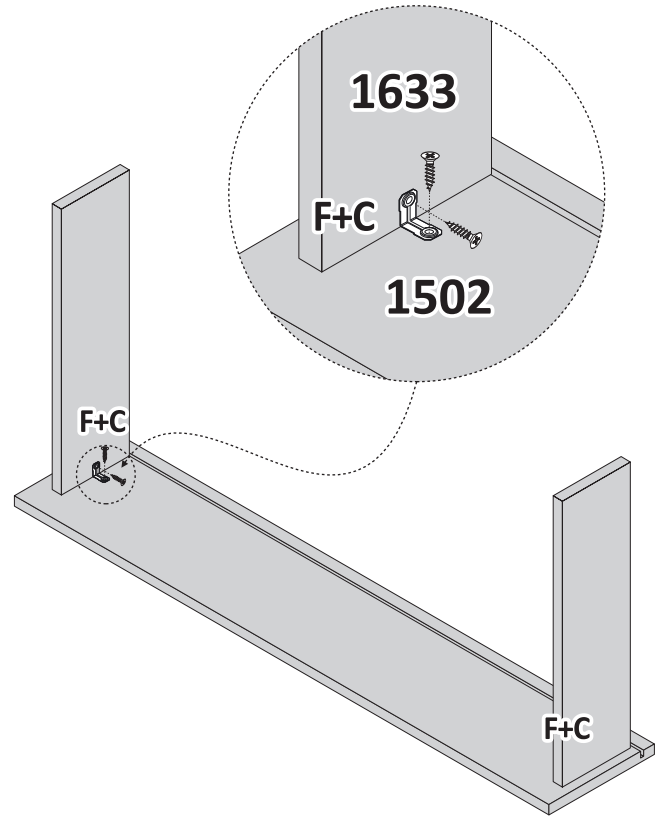
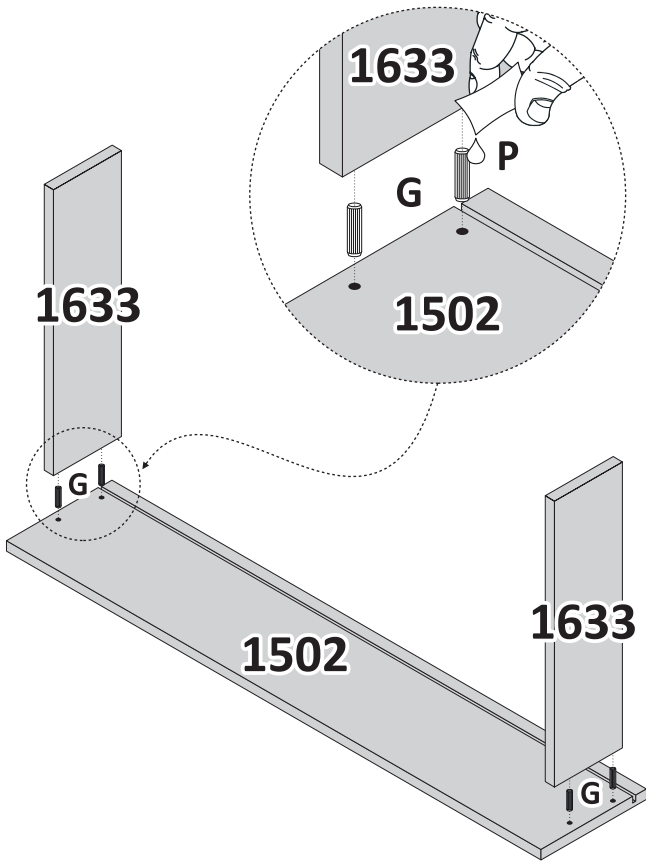

Produto montado.

Asembled product.
Producto ensamblado.

32 98887667
M

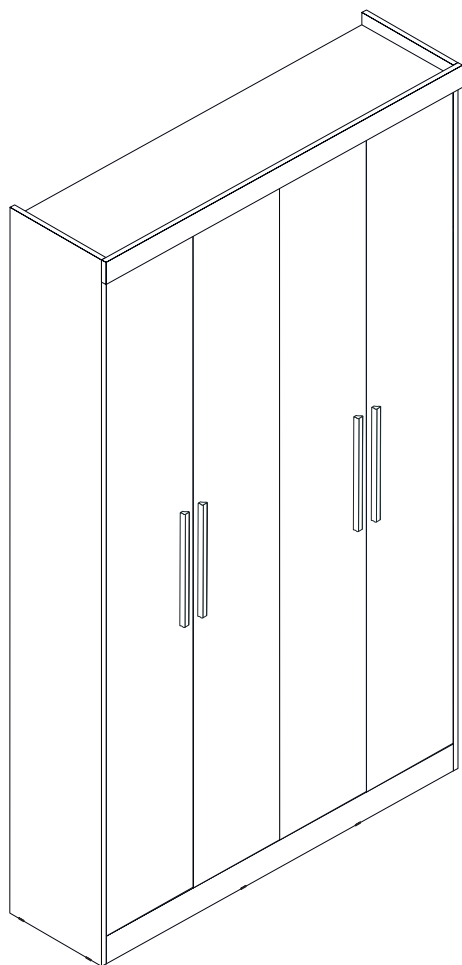

RP 85400

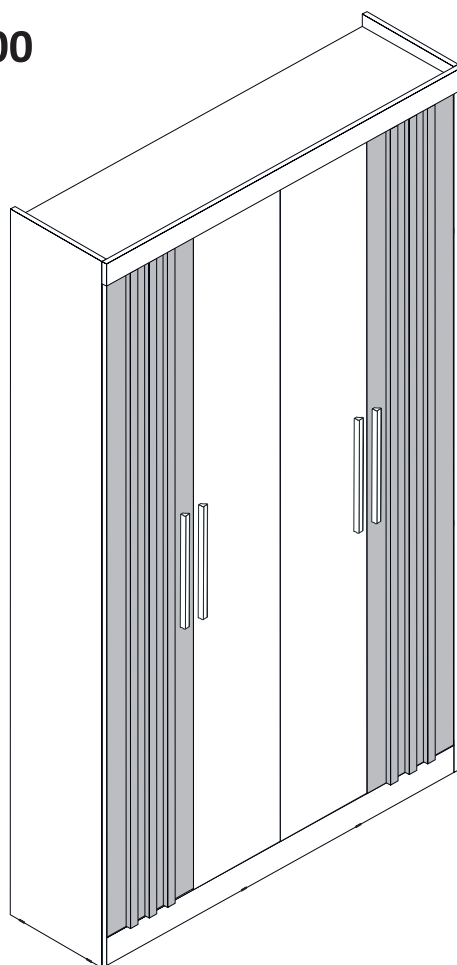

RP 485400

PORTA RIPADA
SLATTED DOOR
PUERTA RANURADA

Doripel
móveis

Moveis.Doripel 

DoripelMoveis 

54 3358.6500 

Av. Julio Vanzin, 1600 - Área Industrial Lagoa Vermelha - RS - Brasil 

comercial@doripel.com.br | assistencia@doripel.com.br 

doripel.com.br 