



Ind. e Com. de Móveis Henn
Mondai - SC - Brasil

+55 49 3674.3500

@moveishenn
www.henn.com.br

INSTRUÇÕES DE MONTAGEM

INSTRUCCIONES DE MONTAJE
ASSEMBLY INSTRUCTIONS

Roupeiro 04 Portas e 02 Gavetas | Armario 04 puertas y 02 cajones | Wardrobe 04 Doors 02 Drawers

- BS02-127 Nature/OFF White
 BS02-130 Castanho HP

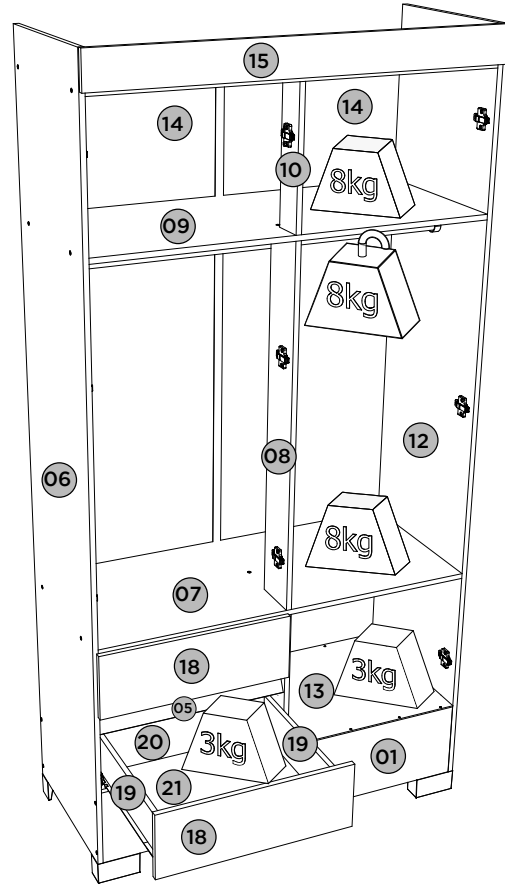

Pesos máximos recomendados com carga distribuída
Peso máximo recomendado con la carga distribuida
Recommended maximum weights with evenly distributed.

Requisitos para montagem Requisitos para la montaje Assembly Requirements

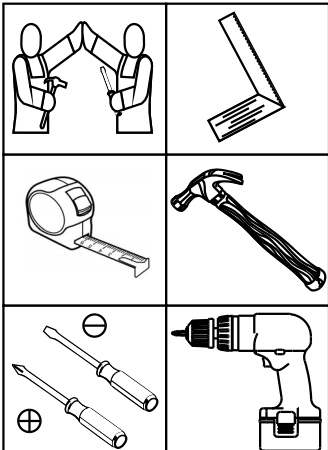

Imagens meramente ilustrativas,
não acompanha o produto.
Imágenes ilustrativas, no incluidas
con el producto.
Illustrative images, not included
with the product.

AVISO

Para limpeza de seu móvel, use uma flanela seca ou umedecida, e não utilize produtos químicos que possam danificar seu produto.

SISTEMA DE MONTAGEM

O sistema de montagem dos produtos, funciona de acordo com a ordem crescente dos números indicados no desenho. Ex: 01, 02, 03, 04... até a conclusão da montagem.

ASSISTÊNCIA TÉCNICA

Para solicitação de Assistência Técnica você consumidor deverá entrar em contato com o Lojista o qual você realizou a compra deste produto e solicitar a assistência técnica das peças avariadas. A garantia abrange todas as peças, partes e componentes que eventualmente venham apresentar defeito de fabricação no prazo de 03 (três) meses, contando a partir da entrega do produto ao consumidor, mediante nota fiscal de compra. Se houver qualquer alteração na estrutura do produto ou ocorrer defeito por negligência do montador/consumidor em relação a instrução de montagem e manuseio, não será fornecida assistência técnica gratuita.

ADVERTENCIA

Para limpieza de su móvil, use una flanela seca o húmeda, y no utilice productos químicos que puedan dañar su producto.

SISTEMA DE MONTAJE

El sistema de montaje de los productos funciona de acuerdo con el orden creciente de los números indicados en el dibujo. Ej.: 01, 02, 03, 04... hasta la conclusión del montaje.

ASISTENCIA TÉCNICA

Para solicitar Asistencia Técnica, el consumidor debe comunicarse con el Comercio que usted realizó la compra de este producto y solicita asistencia técnica para las partes dañadas. La garantía cubre todas las partes, piezas y componentes que eventualmente puedan presentar defecto de fabricación en el plazo de 03 (tres) meses, contados a partir de la entrega del producto al consumidor, mediante factura de compra. Si se produce algún cambio en la estructura del producto o se produce un defecto por negligencia del montador/consumidor en relación con las instrucciones de montaje y manipulación, no se prestará asistencia técnica gratuita.

NOTICE

To clean your furniture, use a dry or wet cloth, and do not use chemicals that may damage your product.

ASSEMBLY SYSTEM

The products' assembly system works according to the increasing order of the indicated numbers. For example: 01, 02, 03, 04 ... to the end of the assembly.

TECHNICAL ASSISTANCE

To request Technical Assistance, the consumer must contact the retailer from whom you purchased this product and request technical assistance for the damaged parts. The warranty covers all parts, parts and components that may eventually present a manufacturing defect within a period of 03 (three) months, counting from the delivery of the product to the consumer, by means of a purchase invoice. If there is any change in the structure of the product or defect occurs due to negligence of the assembler/consumer in relation to the assembly and handling instruction, free technical assistance will not be provided.

1

Vista Inferior

Vista Inferior

Bottom view

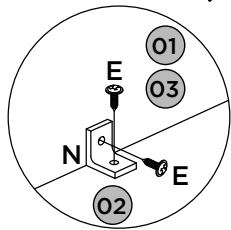
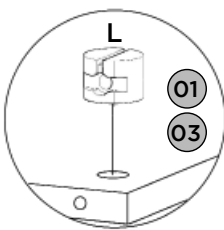
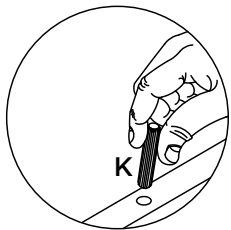
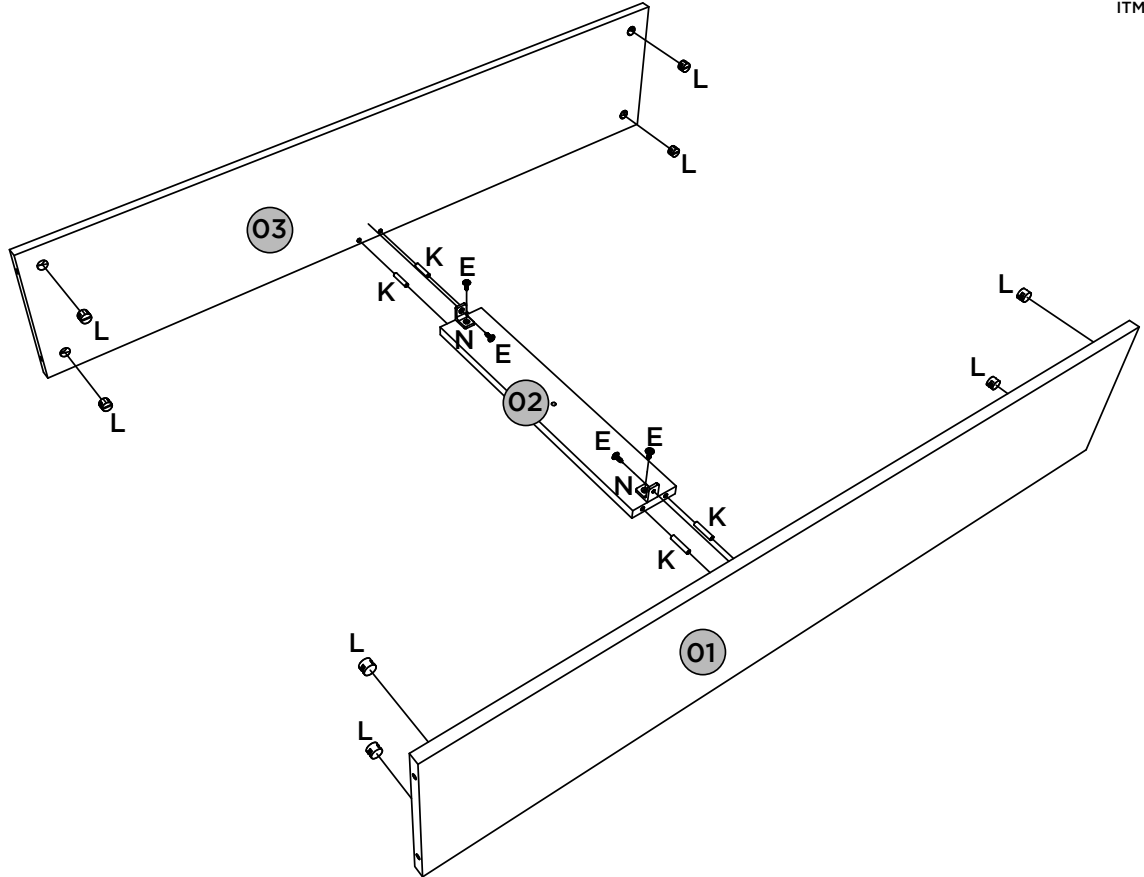

2

Distância Maior para cima

Distancia más larga hacia arriba

Longest Distance Up

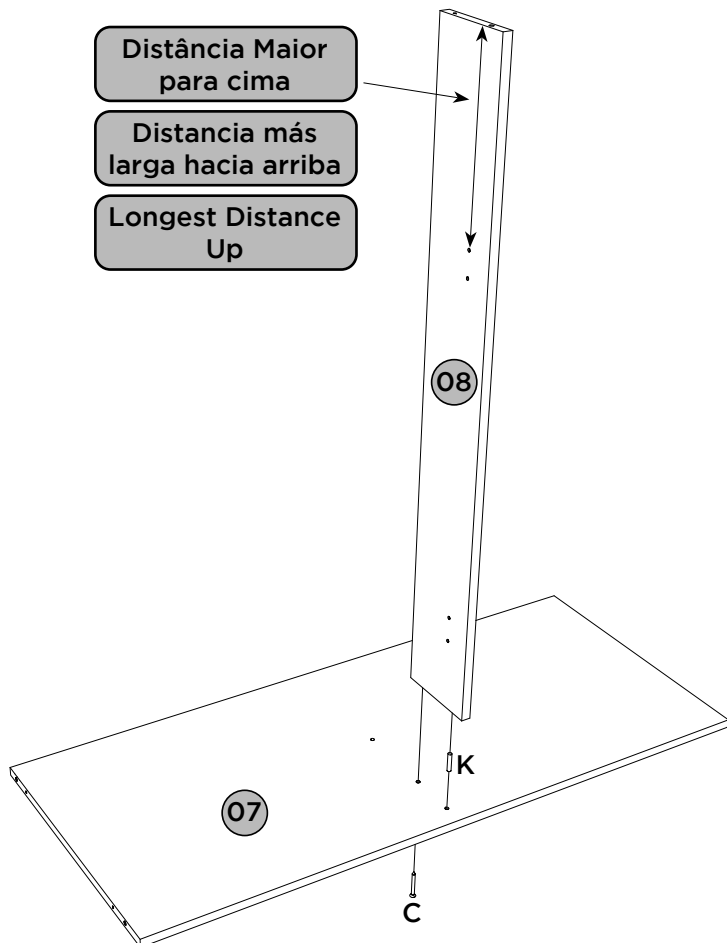

3

Distância Menor para cima

Distancia más corta hacia arriba

Shortest distance up

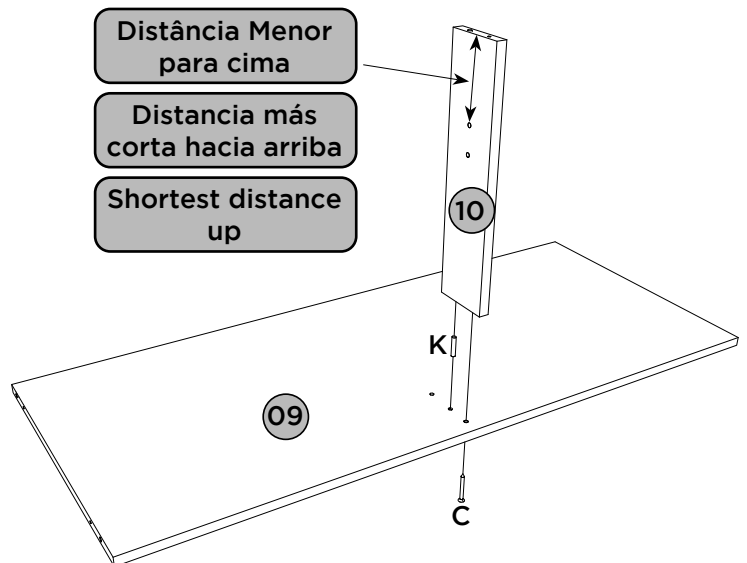

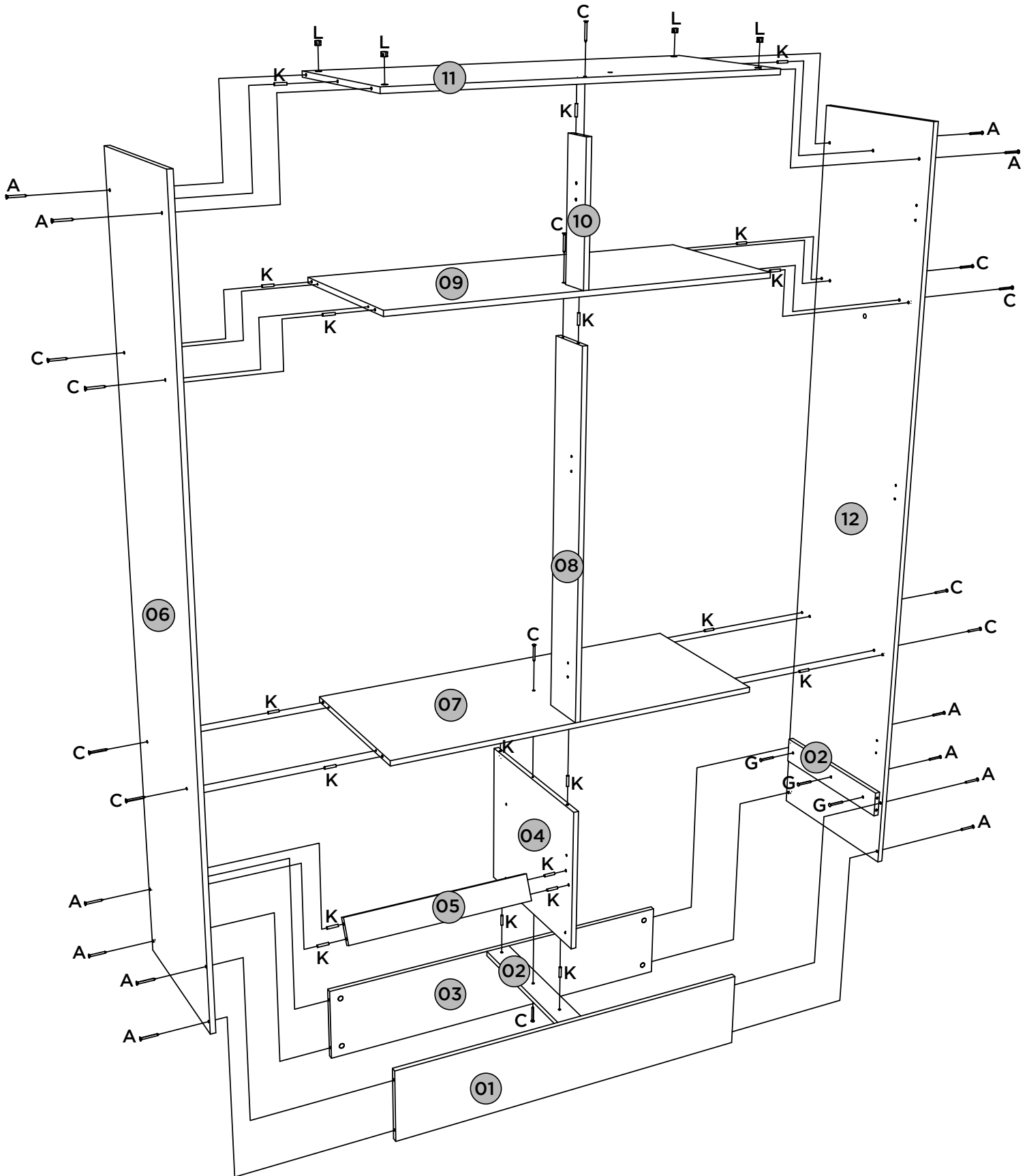

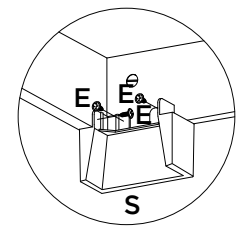
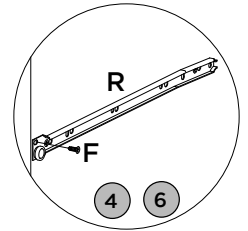
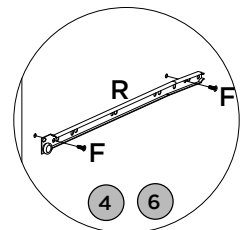
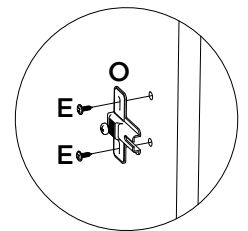
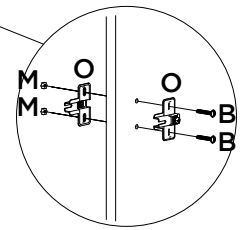
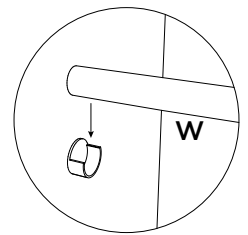
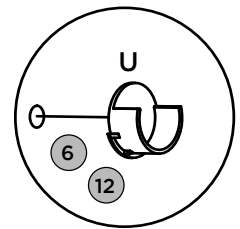

6

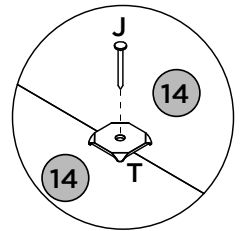
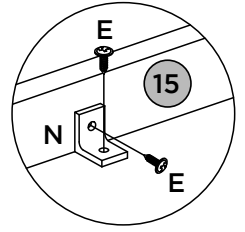
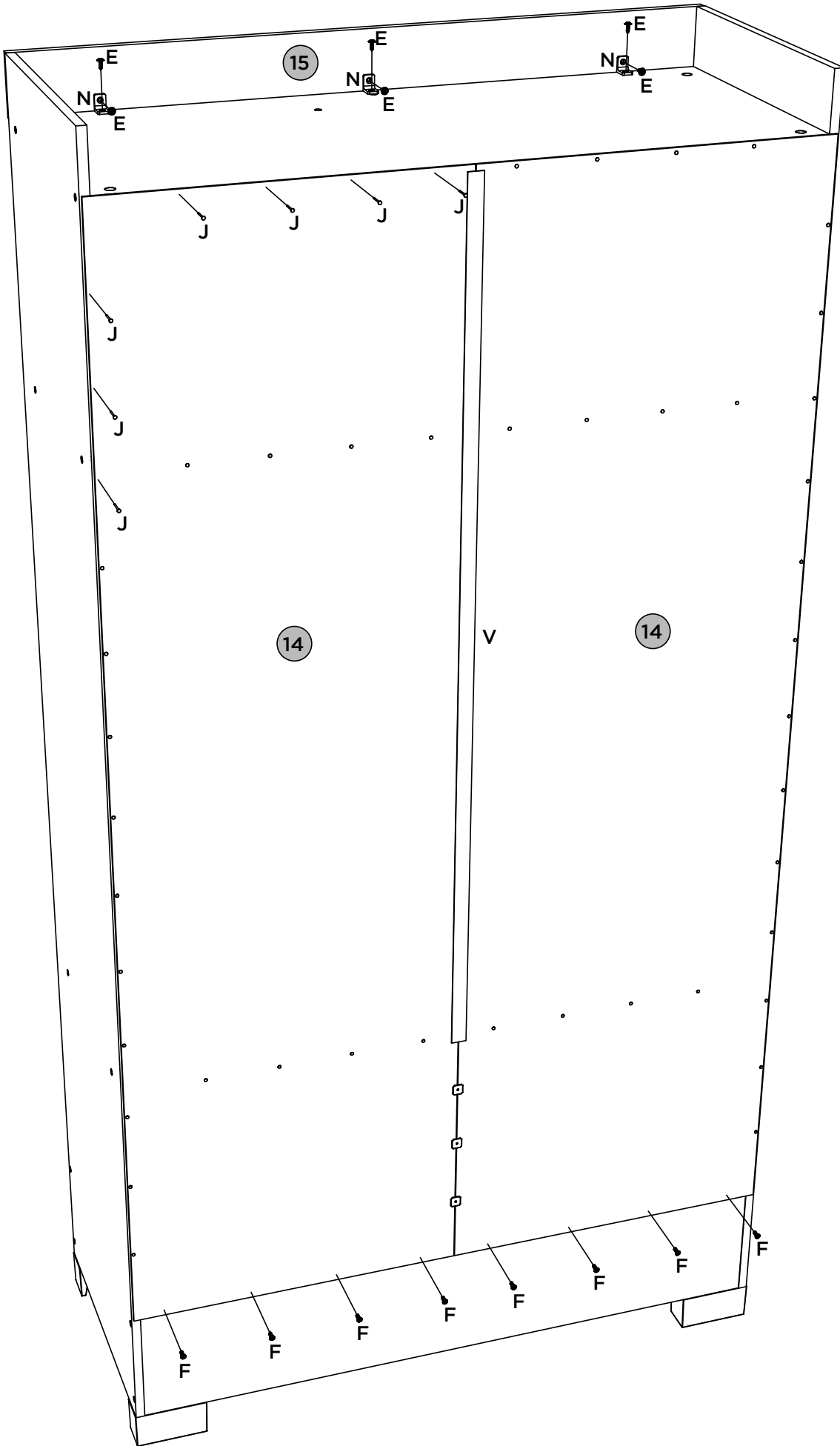

7

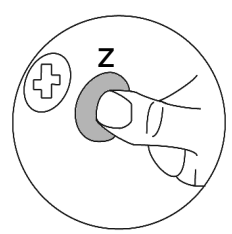
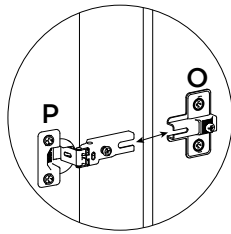
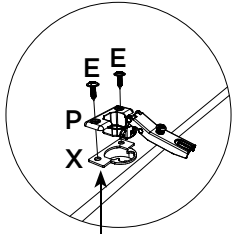
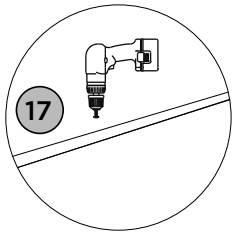

Importante a colocação
do Distanciador (X).

Es importante colocar el
Espaciador (X).

It is important to place
the (X) Spacer.



8

Vista Inferior

Vista Inferior

Bottom view

2X

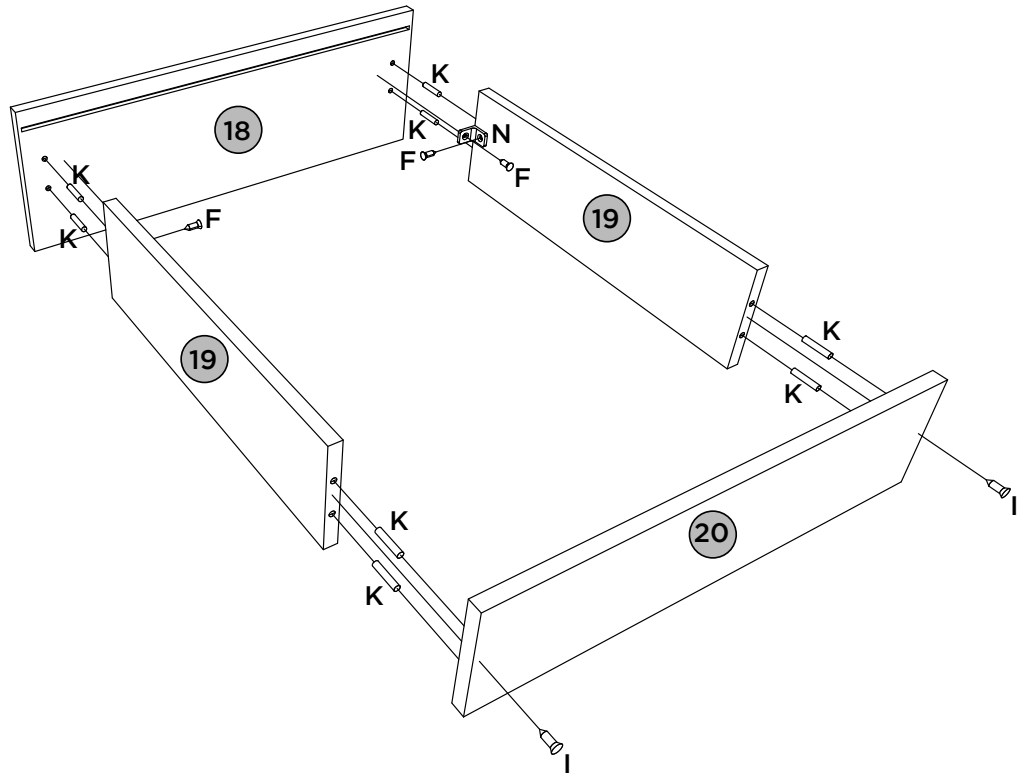
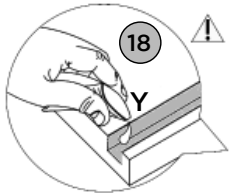
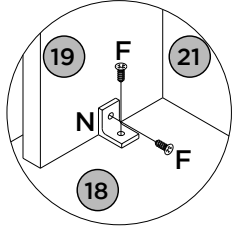
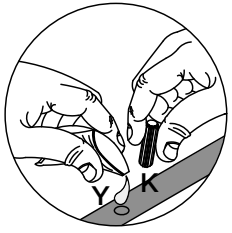



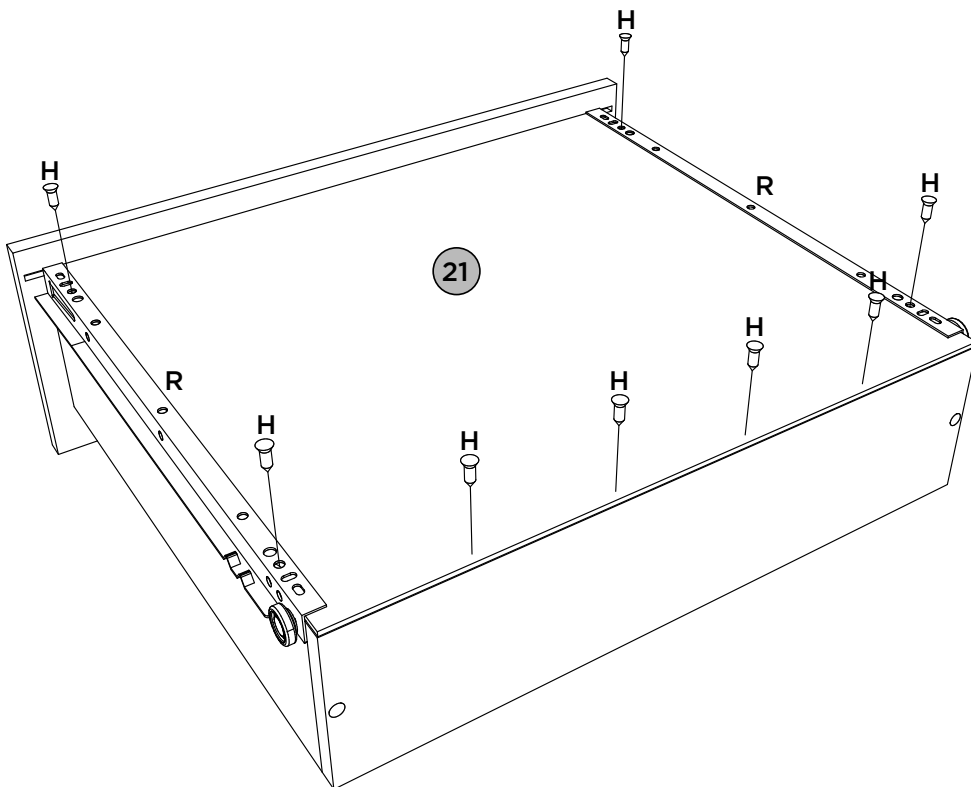







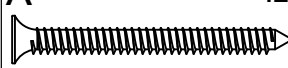
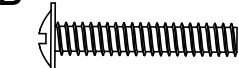





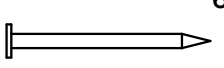

2X

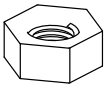
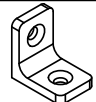
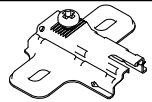
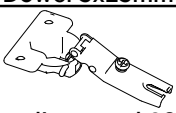
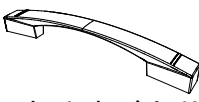

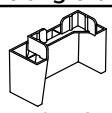
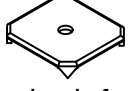
LISTA DE PEÇAS | LISTA DE PIEZAS | PARTS LIST

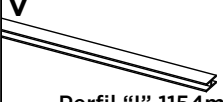
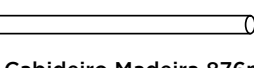
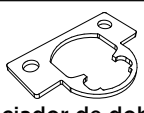
Item	Caixa Caja Box	Qty Ctd Qty	Descrição Descripción Description	Medidas (mm) Dimensions (mm) Size (measurements) (mm)
01	1/1	01	Rodapé frontal Pie frontal Front footboard	882x180x12
02	1/1	02	Travessa Plato Platter	354x60x12
03	1/1	01	Rodapé traseiro Pie trasero Rear footboard	882x180x12
04	1/1	01	Divisão das gavetas División de cajones Drawers division	337x380x12
05	1/1	01	Travessa Frontal Travesaño delantero Front crosspiece	435x60x12
06	1/1	01	Lateral esquerda Lateral izquierdo Left side	1750x380x12
07	1/1	01	Tampa da cômoda Cubierta aparador Dresser top	882x380x12
08	1/1	01	Pilastra da porta Puerta Pilastra Door pilaster	821x110x12
09	1/1	01	Chão do maleiro Planta de la taquilla de equipaje Luggage rack floor	882x380x12
10	1/1	01	Ripa do maleiro Portaequipajes de ripa Luggage rack batten	300x73x12
11	1/1	01	Tampo Cubierta Cover	882x380x12
12	1/1	01	Lateral direita Lateral derecho Right side	1750x380x12
13	1/1	01	Base 3mm Base 3mm Base 3mm	435x380x3
14	1/1	02	Fundo Fondo Bottom	1509x450x3
15	1/1	01	Chapéu Sombrero Hat	904x80x12
16	1/1	02	Porta Puerta Door	1490x220x12
17	1/1	02	Porta menor puerta más pequeña Smaller door	1141x220x12
18	1/1	02	Frente de gaveta Frente de cajón Drawer front	443x152x12
19	1/1	04	Lado de gaveta Lado del cajón Drawer side	350x100x12
20	1/1	02	Ripa de trás Malla detrás Rear batten	410x100x12
21	1/1	02	Fundo de gaveta Fondo del cajón Drawer bottom	409x367x3

FERRAGENS | HERRAJES | HARDWARE

A	12x		Parafuso 4,5x50mm CHT. Tornillo 4,5x50mm CHT. Screw 4,5x50mm CHT.
B	02x		Parafuso 4,0x22mm FLA. Tornillo 4,0x22mm FLA. Screw 4,0x22mm FLA.
C	14x		Parafuso 3,5x40mm CHT. Tornillo 3,5x40mm CHT. Screw 3,5x40mm CHT.
D	08x		Parafuso 3,5x25mm FLA. Tornillo 3,5x25mm FLA. Screw 3,5x25mm FLA.
E	66x		Parafuso 3,5x12mm FLA. Tornillo 3,5x12mm FLA. Screw 3,5x12mm FLA.
F	27x		Parafuso 3,5x12mm CHT. Tornillo 3,5x12mm CHT. Screw 3,5x12mm CHT.
G	03x		Parafuso 3,0x20mm CHT. Tornillo 3,0x20mm CHT. Screw 3,0x20mm CHT.
H	16x		Parafuso 3,0x16mm CHT. Tornillo 3,0x16mm CHT. Screw 3,0x16mm CHT.
I	04x		Prego 12x12mm Anelado Clavo 12x12mm Anillado Ringed Nails 12x12mm
J	65x		Prego 10x10mm Clavo 10x10mm Nail 10x10mm
K	42x		Cavilha 5x25mm Cinta 5x25mm Dowel 5x25mm
L	12x		Porca cilíndrica Tuerca cilíndrica Cylindrical nut
M	02x		Porca Sextavada Tuerca Hexagonal Hexagon Nut
N	09x		Cantoneira plástica Cantonera plástica Plastic angle brackets
O	12x		Calço metal 5mm Calzado metálico 5mm 5mm metal shim
P	12x		Dobradiça metal 26mm Bisagra de metal 26mm 26mm metal hinge
Q	04x		Puxador Indonésia 128mm Tirador Indonésia 128mm 128mm Indonésia Handle
R	02x		Corrediça metal 350mm Corredera de metal 350mm Sliding metal 350mm
S	04x		Pé "U" 50x40x100mm Pie "U" 50x40x100mm 50x40x100mm "U" feet
T	03x		Fixador de fundos Fijador de fondos Bottom fixer
U	02x		Suporte cabideiro Soporte de percha Coat hanger support
V	01x		Perfil "I" 1154mm Perfil "I" 1154mm Profile "I" 1154mm
W	01x		Cabideiro Madeira 876mm Cabezal Madera 876mm 876mm wooden hanger
X	12x		Distanciador de dobradiça Espaciador de bisagra Hinge Spacer
Y	01x		Sachê de cola Bolsa de pegamento Glue bag
Z	22x		Adesivo tapa parafuso 10mm Adhesivo tapón de tornillo 10mm Bolt cover adhesive 10mm
AA	01x		Etiqueta resinada Briz Etiqueta resinada Briz Briz resin label