



Nº	CÓDIGO CODE ASSISTÊNCIA ATTENDANCE	NOME DA PEÇA/DESCRIPCIÓN PIEZAS/DESCRIPTION PARTS	MEDIDAS (mm) MEASURES (mm)	QTD.	MARROCOS OFF WHITE	BRANCO NEVE BRANCO NEVE	CINAMOMO OFF WHITE
01	RD041.13.01	Forro/Revés/botton	1700x454x2.5	02	324214	324214	324214
02	RD041.25.00	Porta/Puerta/Door	1671x449x15	02	280374	325464	325437
03	RD041.04.00	Base sob gaveta/Base cajón/Shelf	441x387x12	01	277775	277775	277775
04	RD041.02.00	Base interna/Base/Shelf	440x387x12	01	277773	277773	277773
05	RD041.34.00	Forro gaveta/Revés cajón/Botton	365x355x2.5	02	277771	277771	277771
06	RD041.17.00	Lateral externa direita/Lateral derecha/Inner side	1850x450x12	01	277946	277916	325444
07	RD041.05.00	Base superior/Base superior/Shelf	893x450x12	01	277776	277776	277776
08	RD041.01.00	Base inferior/Base inferior/Shelf	893x450x12	01	277963	277967	325443
09	RD041.15.00	Lateral gaveta/Lateral cajón/ Drawer side	350x100x12	04	277779	277779	277779
10	RD041.30.00	Rodapé frontal/Zócalo delantero/Front panel	893x88x12	01	277948	277918	325446
11	RD041.32.00	Rodapé traseiro/Zócalo de atrás/Border back	893x88x12	01	277786	277786	277786
12	RD041.07.00	Chapéu/Detalle superior/Hat	917x88x15	01	277949	277919	277919
13	RD041.14.00	Frente gaveta/Frente cajón/Drawer front	420x150x12	02	278384	278384	278384
14	RD041.27.00	Prateleira interna/Repisa/Shelf	441x387x12	01	277783	277783	277783
15	RD041.29.00	Ripa Traseira de gaveta/Trasero cajón/Drawer back	341x80x12	02	277784	277784	277784
16	RD041.19.00	Lateral interna central/Divisória interna/Inner side	1274x387x12	01	277782	277782	277782
17	RD041.18.00	Lateral externa esquerda/Lateral izquierda/Inner side	1850x450x12	01	277947	277917	325445
18	RD041.03.00	Base maleiro/Base/Shelf	893x387x12	01	277774	277774	277774
19	RD041.06.00	Ripa batente/Divisória/Batten clapboard	400x70x12	01	277777	277777	277777
20	4862	Espelho/Espejo/Mirror	600X400X2	02			

Ferragens/Herrajes/Hardware

A  **14x**
Cód 873
Cavilha/Clavija/Peg Ø 6,0x30mm

B  **36x**
Cód 691
Parafuso/Tornillo/Screw 3,5x40mm Chat

C  **26x**
Cód 11413
Parafuso/Tornillo/Screw 3x12mm Chat

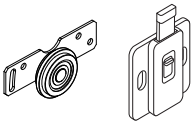
D  **02x**
Cód 2495
Sistema de correr/sistema deslizante/sliding system

E  **12x**
Cód 667
Parafuso/Tornillo/Screw 4x14mm Chat

F  **01x**
Cód 7786
Perfil/Profile I 400mm

G  **20x**
Cód 7604
Parafuso/Tornillo/Screw 4x12mm Chat

H  **04x**
Cód 790
Suporte prateleira/ Soporte de estante/ Shelf support

I  **15x**
Cód 7169
Fixador costa/Ujetador de orilla/Shore fastener

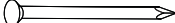
J  **52x**
Cód 822
Prego/Clavo/Nail

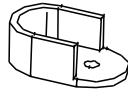
K  **02x**
Cód 857
Suporte cabideiro/Soporte de suspensión/ hanger support

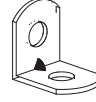
L  **07x**
Cód 7168
Cantoneira metálica/angulo metálico Metal angle bracket

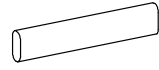
M  **01x**
Cód 12252
Cabideiro/Tendedeiro/Wooden hanger 432mm

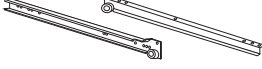
N  **02x**
Cód 594
Corrediças/Diapostivas/Slides

O  **02x**
Cód 12012
Puxador/Manija/Puller

P  **08x**
Cód 728
Distanciador/Espaciador/Spacer 25mm

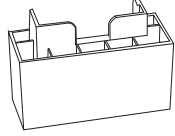
Q  **04x**
Cód 8181
Cód 4083
Cód 13474
Pé plástico/Pie de plástico/Plastic foot

R  **01x**
Cód 13232
Trilho inferior/Riel superior/Bottom rail 890mm

S  **08x**
Cód 9567
Parafuso/Screw 3x22mm Cht.

T  **01x**
Cód 8255
Bisnaga cola/tubo de pegamento/glue tube

U  **08x**
Cód 10681
Batente silicone/tope de silicona/Silicone stop

Obs: a régua serve para medição da ferragem.
Nota: la regla se utiliza para medir el hardware.
Note: the ruler is used to measure the hardware.

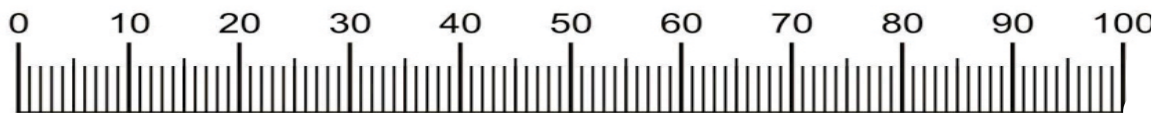

Medidas em mm
Measures in mm
Mesuras en mm

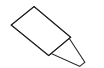
 Produto para ser aplicado em caso de riscos na superfície.

 Product to be applied in case of scratches on the surface.

 Producto para ser aplicado en caso de rayas en la superficie.

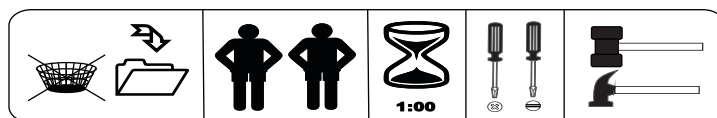

Pré-Montagem/Preparación Piezas/ Pre-assembly

Obs:o distânciador de gaveta (P) é fixado nas peças 6 e 16, com o parafuso 4x14 (G).Em sequência são fixadas as corrediças (N) sobre os distânciadores de gaveta.

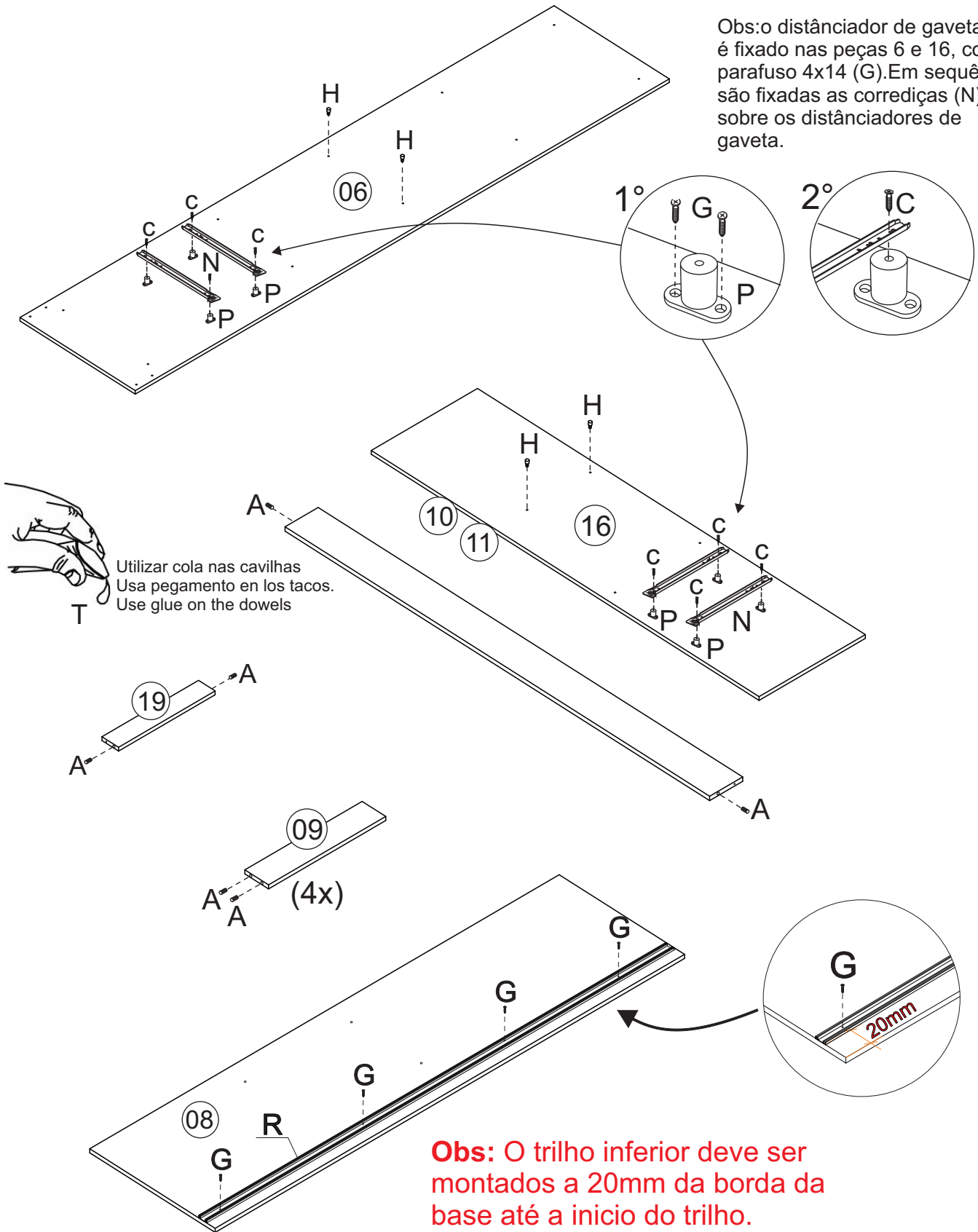

Utilizar cola nas cavilhas
Usa pegamento en los tacos.
Use glue on the dowels

Obs: O trilho inferior deve ser montados a 20mm da borda da base até a inicio do trilho.

Nota: El inferior debe montarse a 20 mm desde el borde de la base hasta el final del riel.

Note: The bottom rail must be mounted 20mm from the edge of the base to the tip of the rail.

Montagem/Montaje/Assembly

01

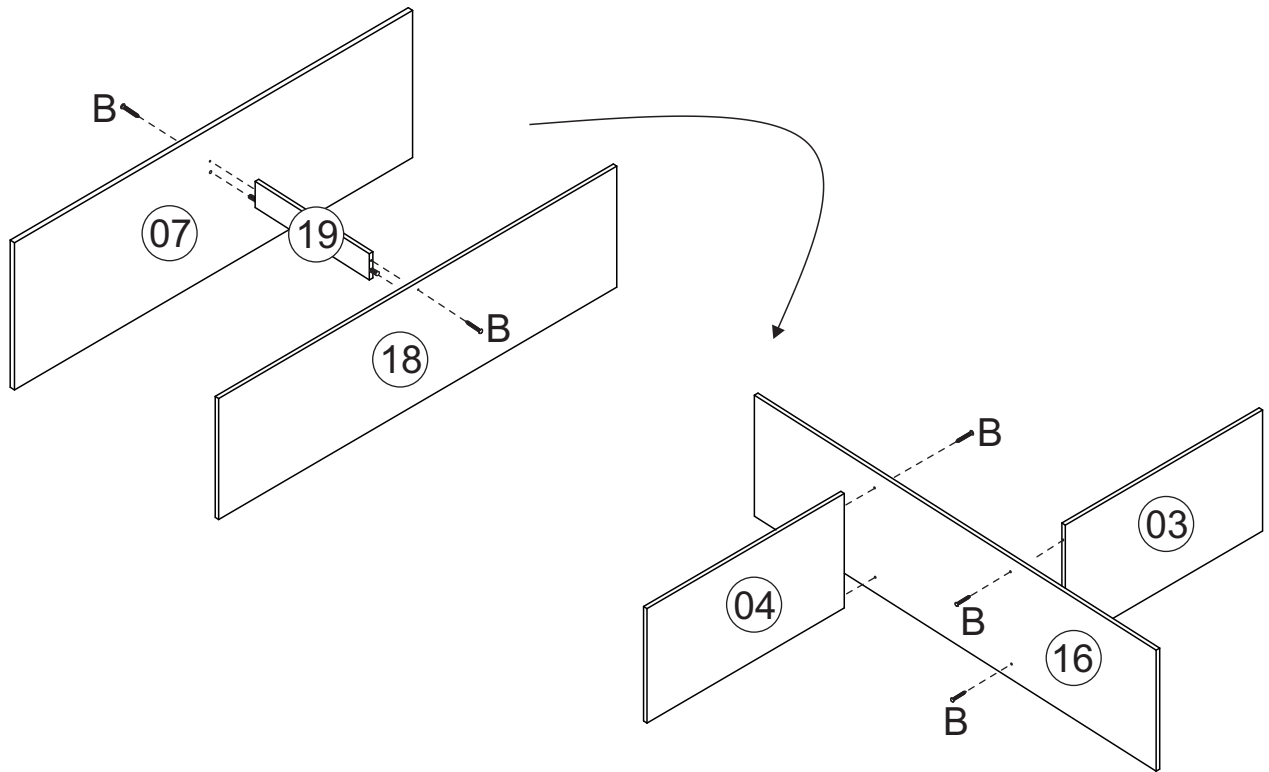

02

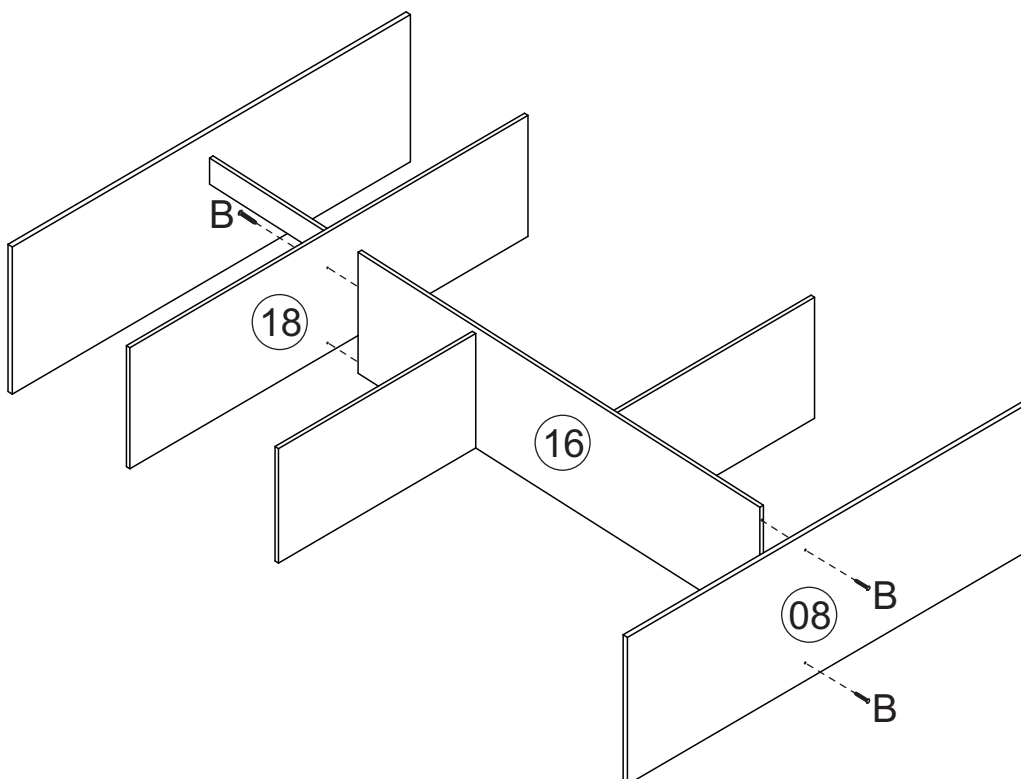

Montagem/Montaje/Assembly

03

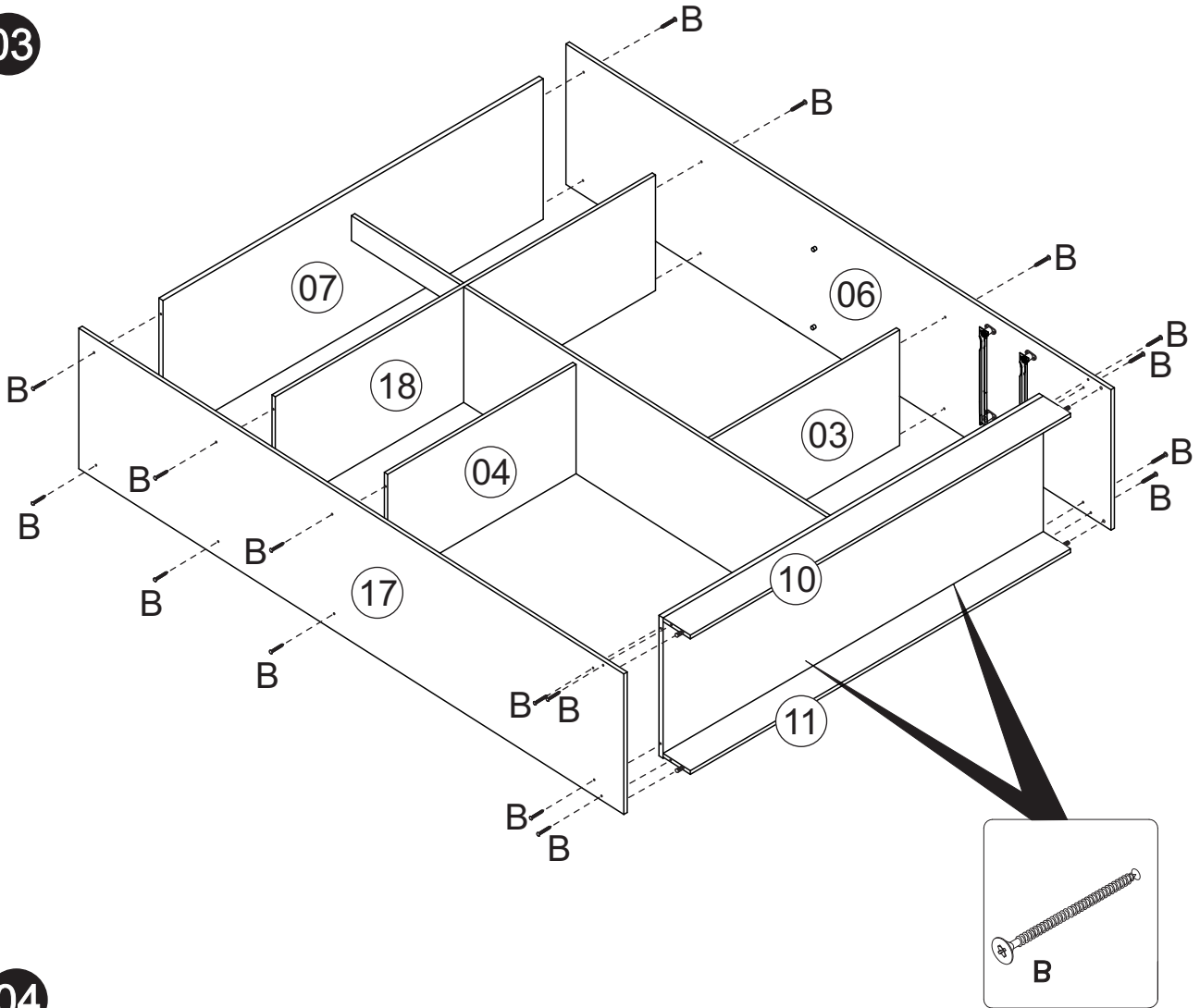

04

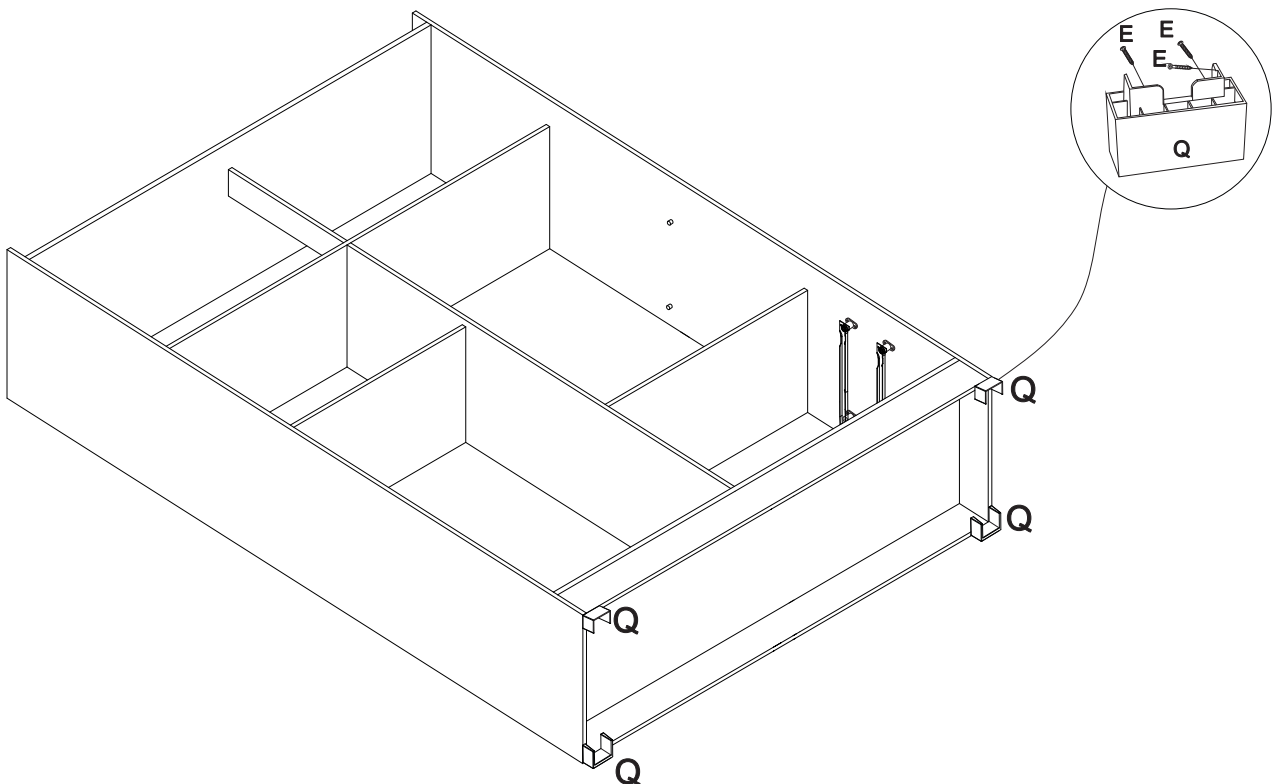

Montagem/Montaje/Assembly

05

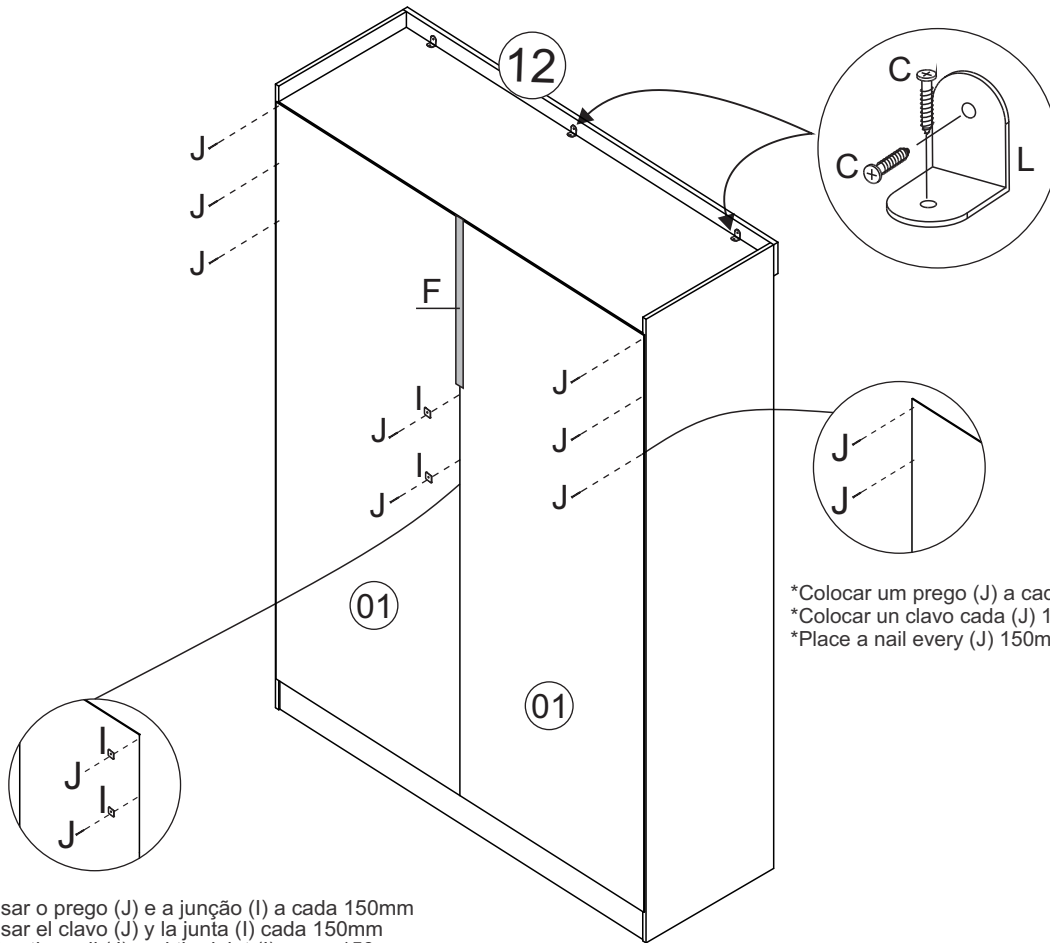

*Colocar um prego (J) a cada 150mm
 *Colocar un clavo cada (J) 150mm
 *Place a nail every (J) 150mm

*Usar o prego (J) e a junção (I) a cada 150mm
 *Usar el clavo (J) y la junta (I) cada 150mm
 *Use the nail (J) and the joint (I) every 150mm

06

(2x)

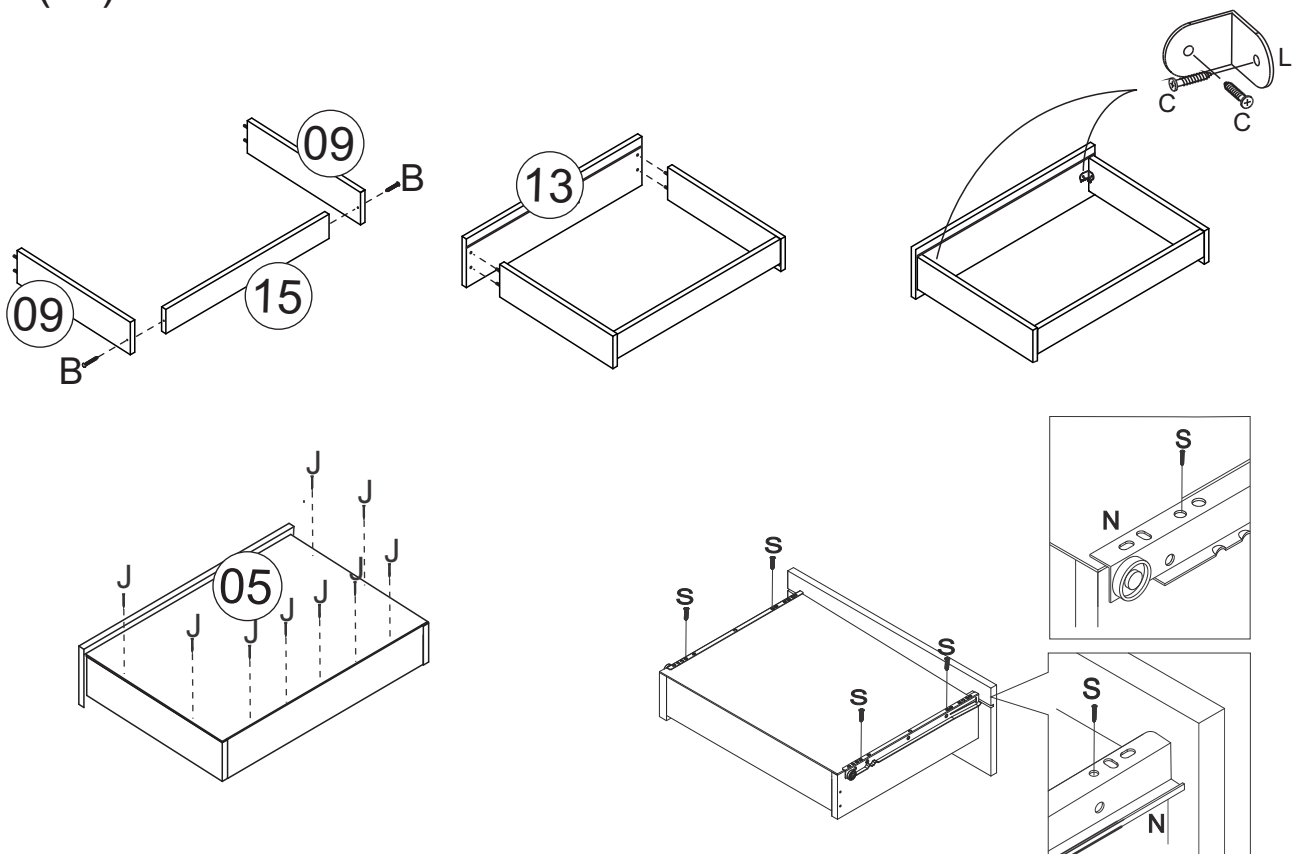

Montagem/Montaje/Assembly

07

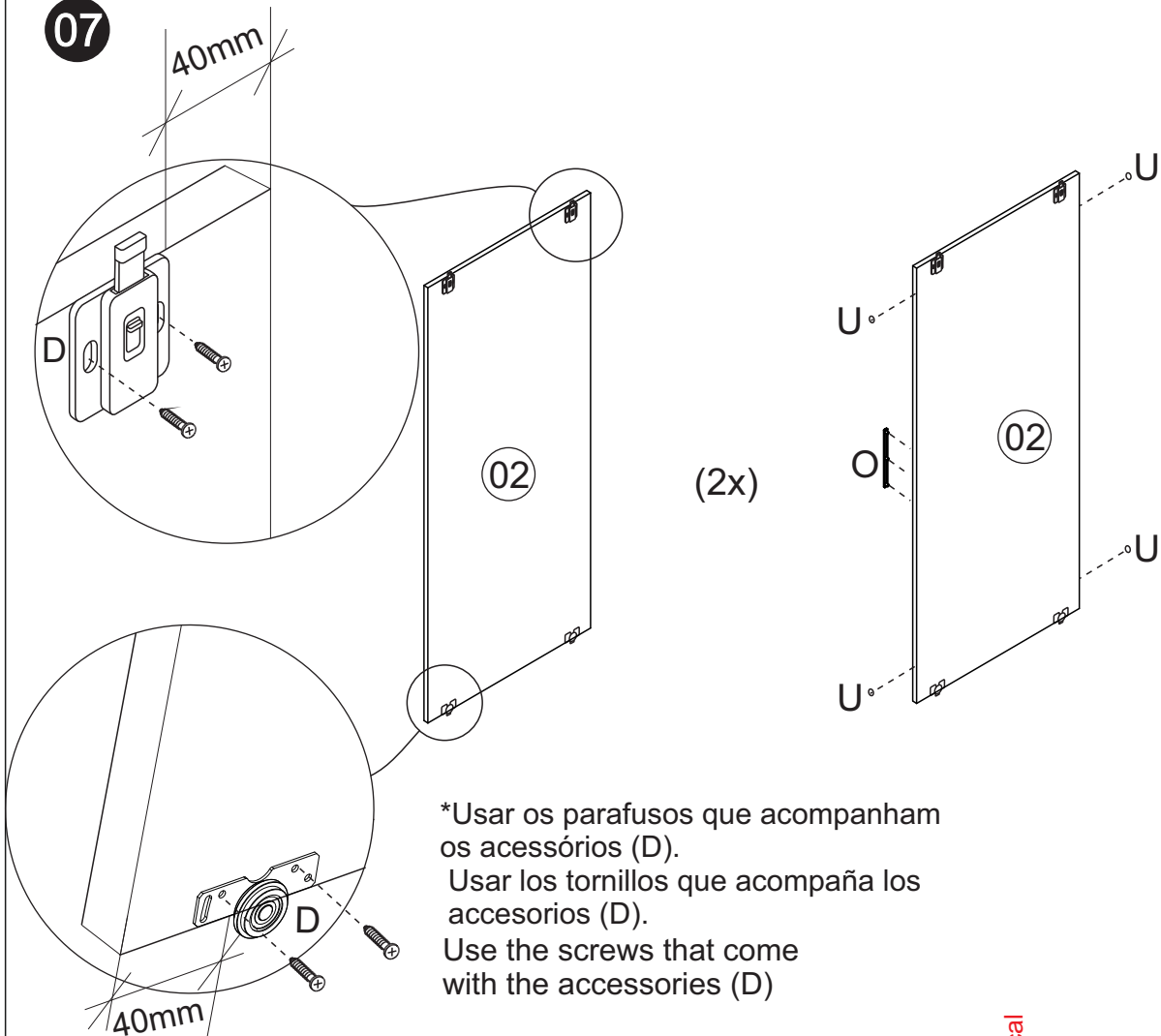

*Usar os parafusos que acompanham os acessórios (D).
 Usar los tornillos que acompaña los accesorios (D).
 Use the screws that come with the accessories (D)

08

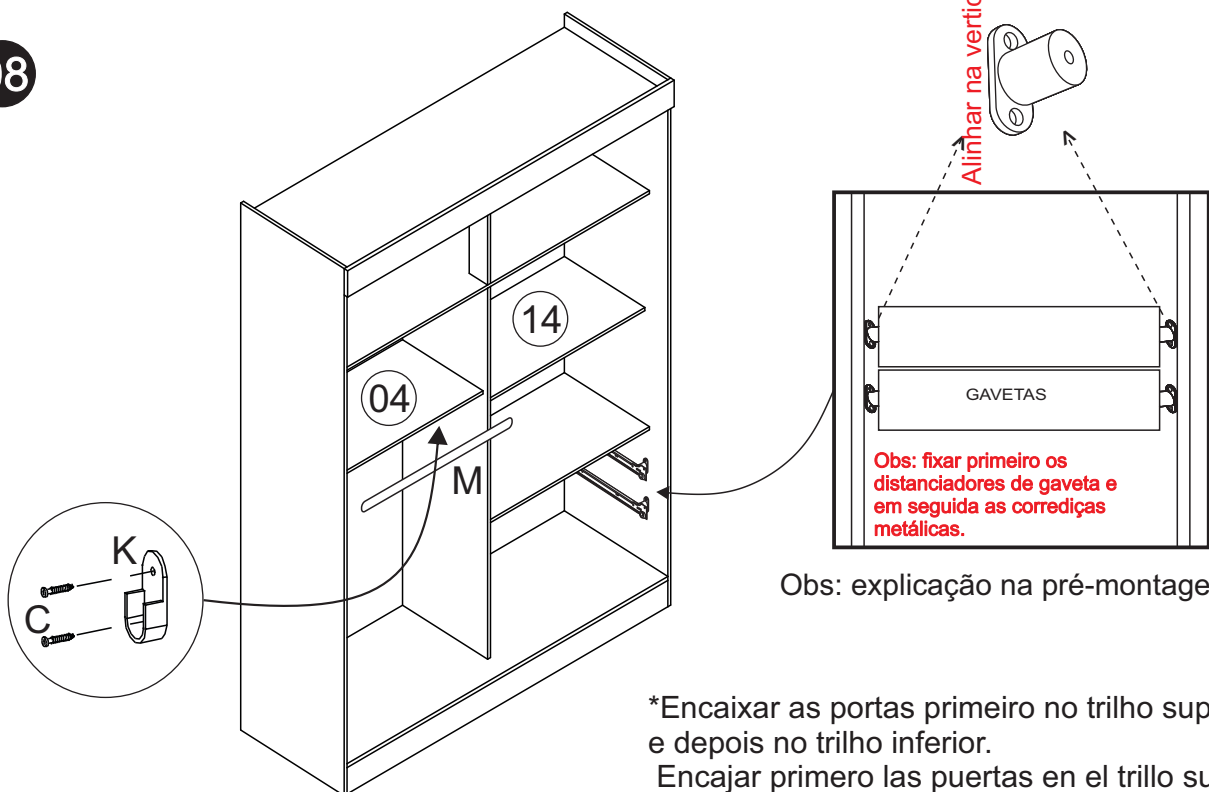

Obs: fixar primeiro os distanciadores de gaveta e em seguida as correijas metálicas.

Obs: explicação na pré-montagem pg.3

*Encaixar as portas primeiro no trilho superior e depois no trilho inferior.
 Encajar primero las puertas en el trillo superior y después en el trillo inferior.
 Fit the doors to the top rail first and then to the bottom rail

Montagem/Montaje/Assembly

08

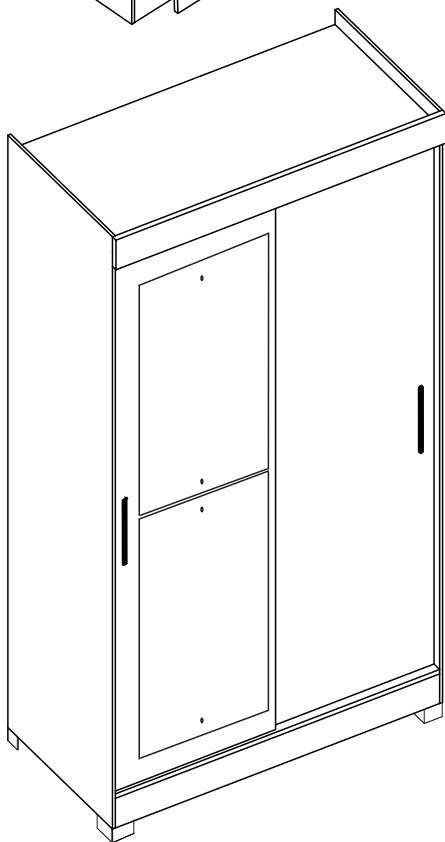
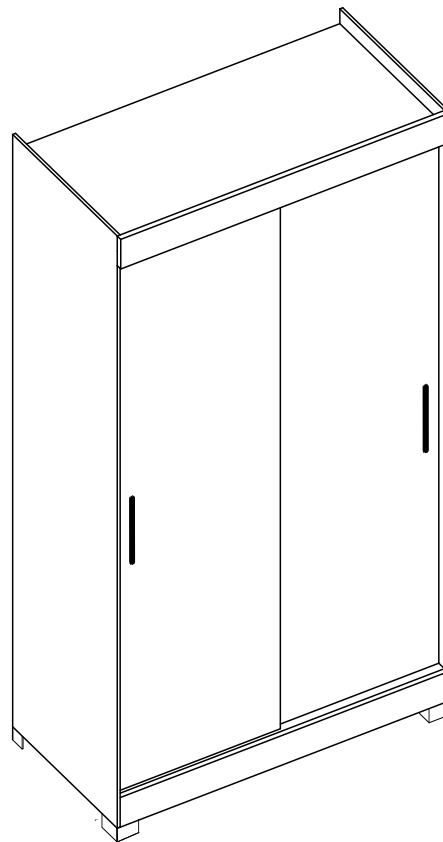
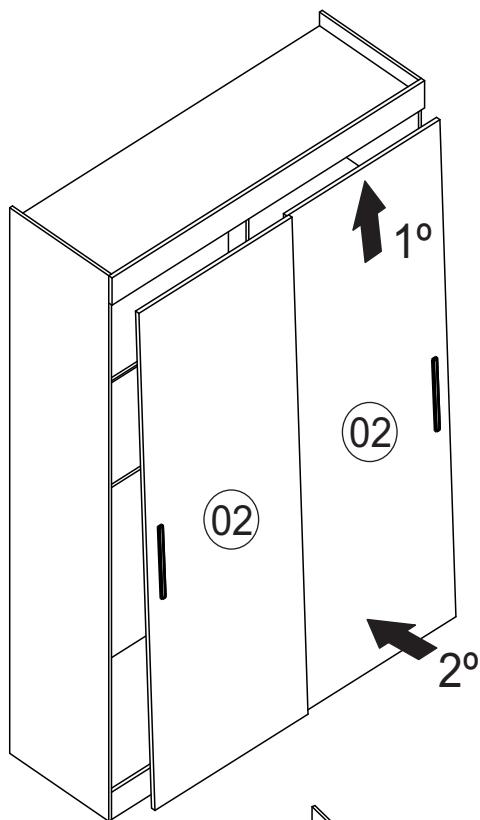

Obs: fixar os espelhos nas portas antes de colocar a porta no roupeiro utilizando a ferragem do kit.

Nota: fije los espejos en las puertas antes de colocar la puerta en el armario usando el hardware del kit.

Note: fix the mirrors on the doors before placing the door in the wardrobe using the hardware from the kit.

Limpeza/Limpieza

- ☞ Use um pano levemente umedecido com água, seguido de pano seco.
- ☞ Use solamente un paño húmedo con agua y después un paño seco.
- ☞ Use a cloth slightly dampened with water, followed by a dry cloth.
- ☞ Nunca utilize produtos químicos ou abrasivos.
- ☞ No utilice productos químicos o abrasivos.
- ☞ Never use chemical or abrasive products.