

ROUPEIRO 05 PORTAS 02 GAVETAS

ARMARIO 05 PUERTAS 02 CAJONES | WARDROBE 05 DOORS 02 DRAWERS

B60-52 CAFÉ/RÚSTICO | B60-74 GRIS/PALHA | B60-101 CAFÉ | B60-111 CAFÉ/CRISTAL
| B60-127 NATURE/OFF WHITE | B60-130 CASTANHO HP | B60-198 JEQUITIBÁ BRILHO

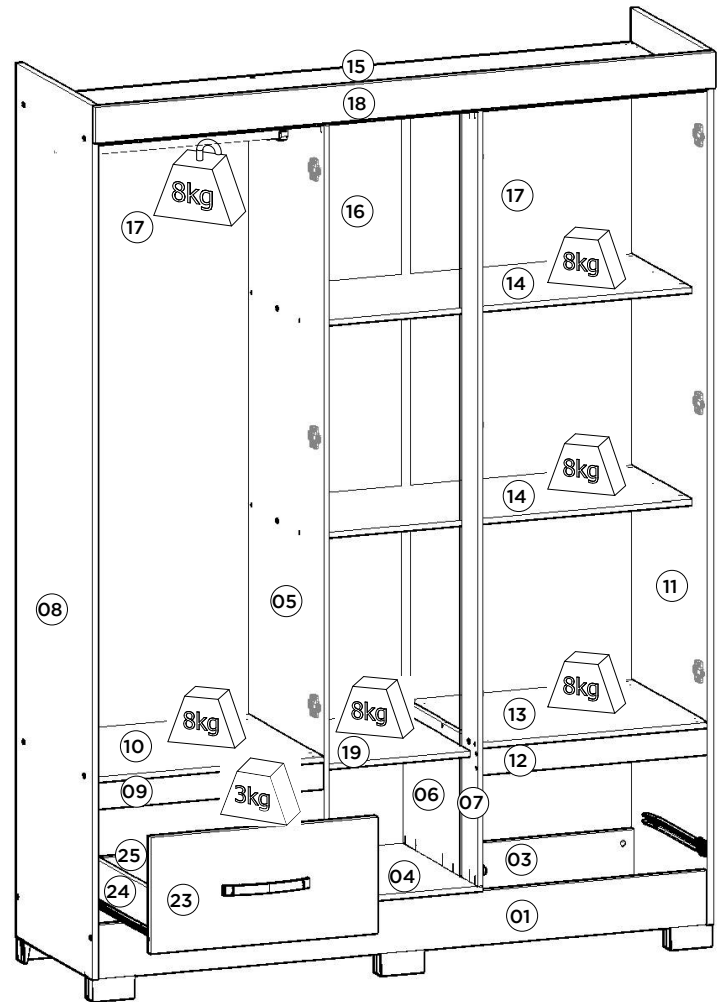
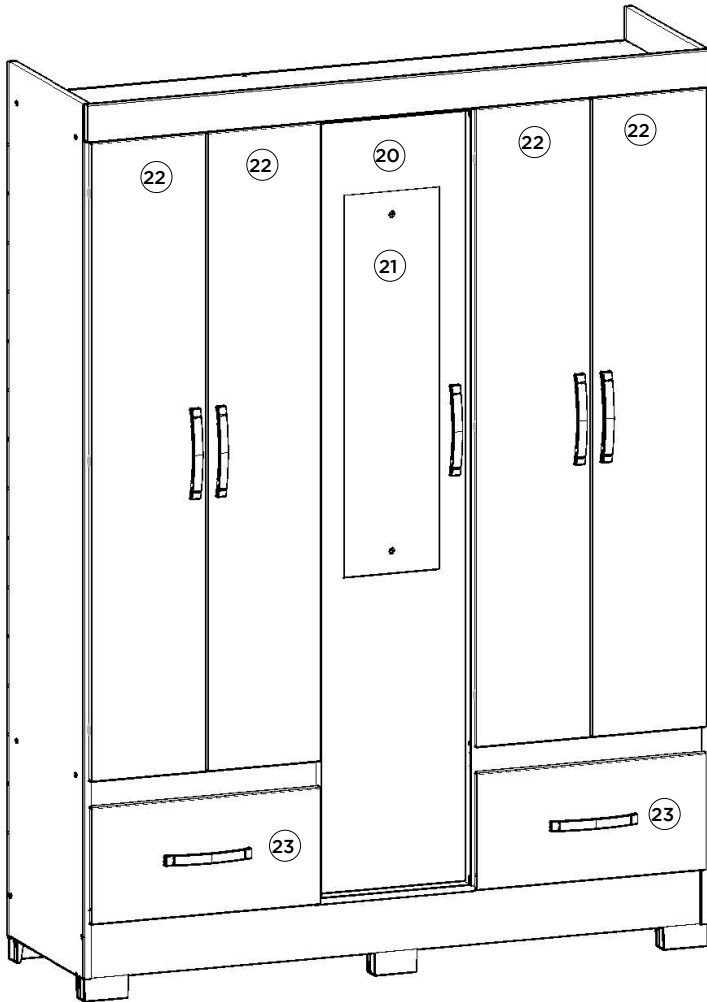

Pesos máximos recomendados com carga distribuída
Peso máximo recomendado con la carga distribuida
Recommended maximum weights with evenly distributed.

Requisitos para montagem
Requisitos para la montaje
Assembly Requirements

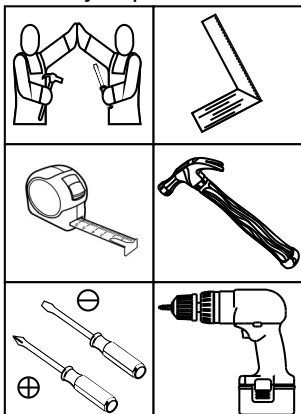

Imagens meramente ilustrativas,
não acompanha o produto.
Imágenes ilustrativas, no incluidas
con el producto.
Illustrative images, not included
with the product.

AVISO

Para limpeza de seu móvel, use uma flanela seca ou umedecida, e não utilize produtos químicos que possam danificar seu produto.

SISTEMA DE MONTAGEM

O sistema de montagem dos produtos, funciona de acordo com a ordem crescente dos números indicados no desenho. Ex: 01, 02, 03, 04... até a conclusão da montagem.

ASSISTÊNCIA TÉCNICA

Para solicitação de Assistência Técnica você consumidor deverá entrar em contato com o Lojista o qual você realizou a compra deste produto e solicitar a assistência técnica das peças avariadas. A garantia abrange todas as peças, partes e componentes que eventualmente venham apresentar defeito de fabricação no prazo de 03 (três) meses, contando a partir da entrega do produto ao consumidor, mediante nota fiscal de compra. Se houver qualquer alteração na estrutura do produto ou ocorrer defeito por negligência do montador/consumidor em relação a instrução de montagem e manuseio, não será fornecido assistência técnica gratuita.

ADVERTENCIA

Para limpieza de su móvil, use una flanela seca o húmeda, y no utilice productos químicos que puedan dañar su producto.

SISTEMA DE MONTAJE

El sistema de montaje de los productos funciona de acuerdo con el orden creciente de los números indicados en el dibujo. Ej.: 01, 02, 03, 04... hasta la conclusión del montaje.

ASISTENCIA TÉCNICA

Para solicitar Asistencia Técnica, el consumidor debe comunicarse con el Comercio que usted realizó la compra de este producto y solicita asistencia técnica para las partes dañadas. La garantía cubre todas las partes, piezas y componentes que eventualmente puedan presentar defecto de fabricación en el plazo de 03 (tres) meses, contados a partir de la entrega del producto al consumidor, mediante factura de compra. Si se produce algún cambio en la estructura del producto o se produce un defecto por negligencia del montador/consumidor en relación con las instrucciones de montaje y manipulación, no se prestará asistencia técnica gratuita.

NOTICE

To clean your furniture, use a dry or wet cloth, and do not use chemicals that may damage your product.

ASSEMBLY SYSTEM

The products' assembly system works according to the increasing order of the indicated numbers. For example: 01, 02, 03, 04 ... to the end of the assembly.

TECHNICAL ASSISTANCE

To request Technical Assistance, the consumer must contact the retailer from whom you purchased this product and request technical assistance for the damaged parts. The warranty covers all parts, parts and components that may eventually present a manufacturing defect within a period of 03 (three) months, counting from the delivery of the product to the consumer, by means of a purchase invoice. If there is any change in the structure of the product or defect occurs due to negligence of the assembler/consumer in relation to the assembly and handling instruction, free technical assistance will not be provided.

1º

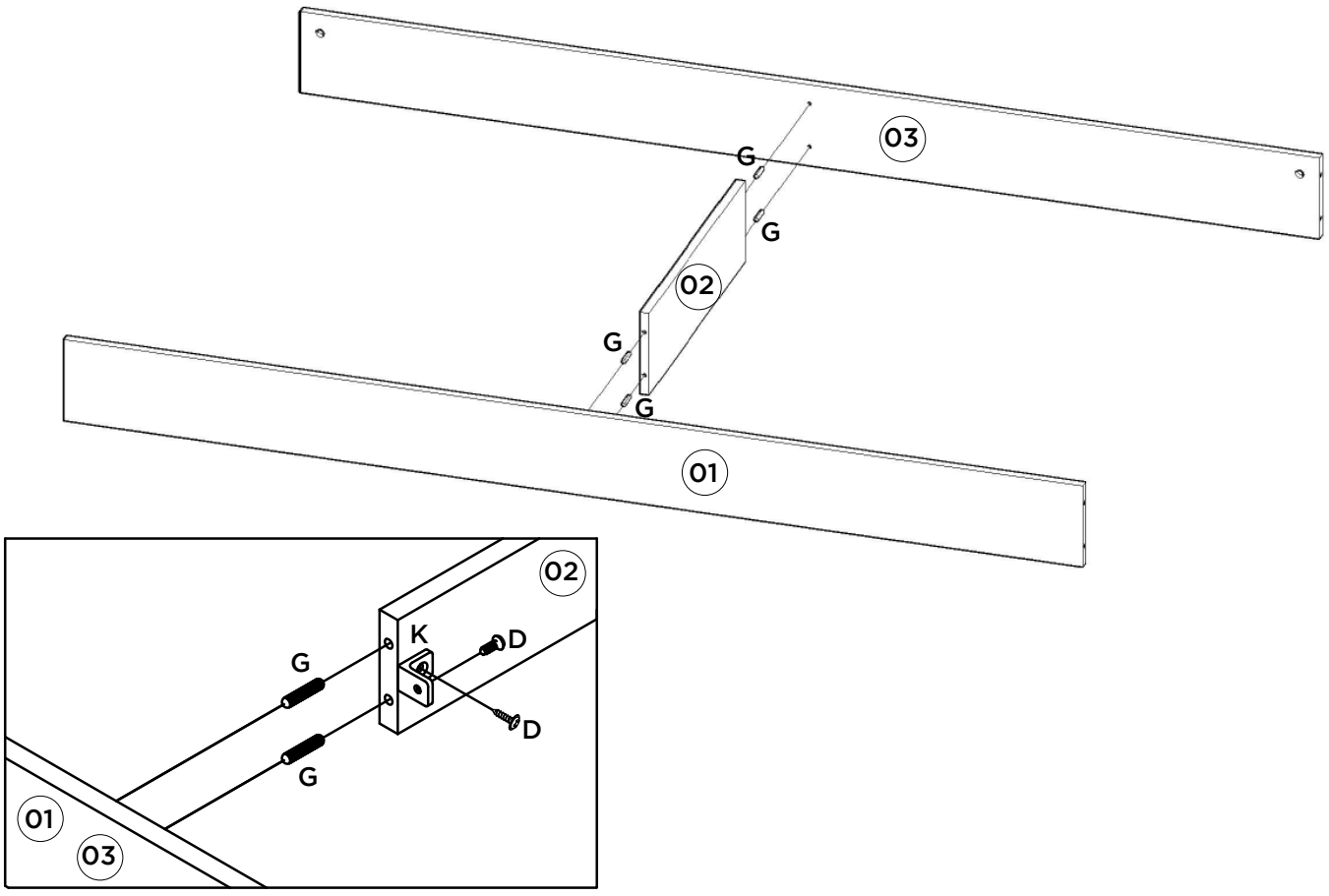

2º

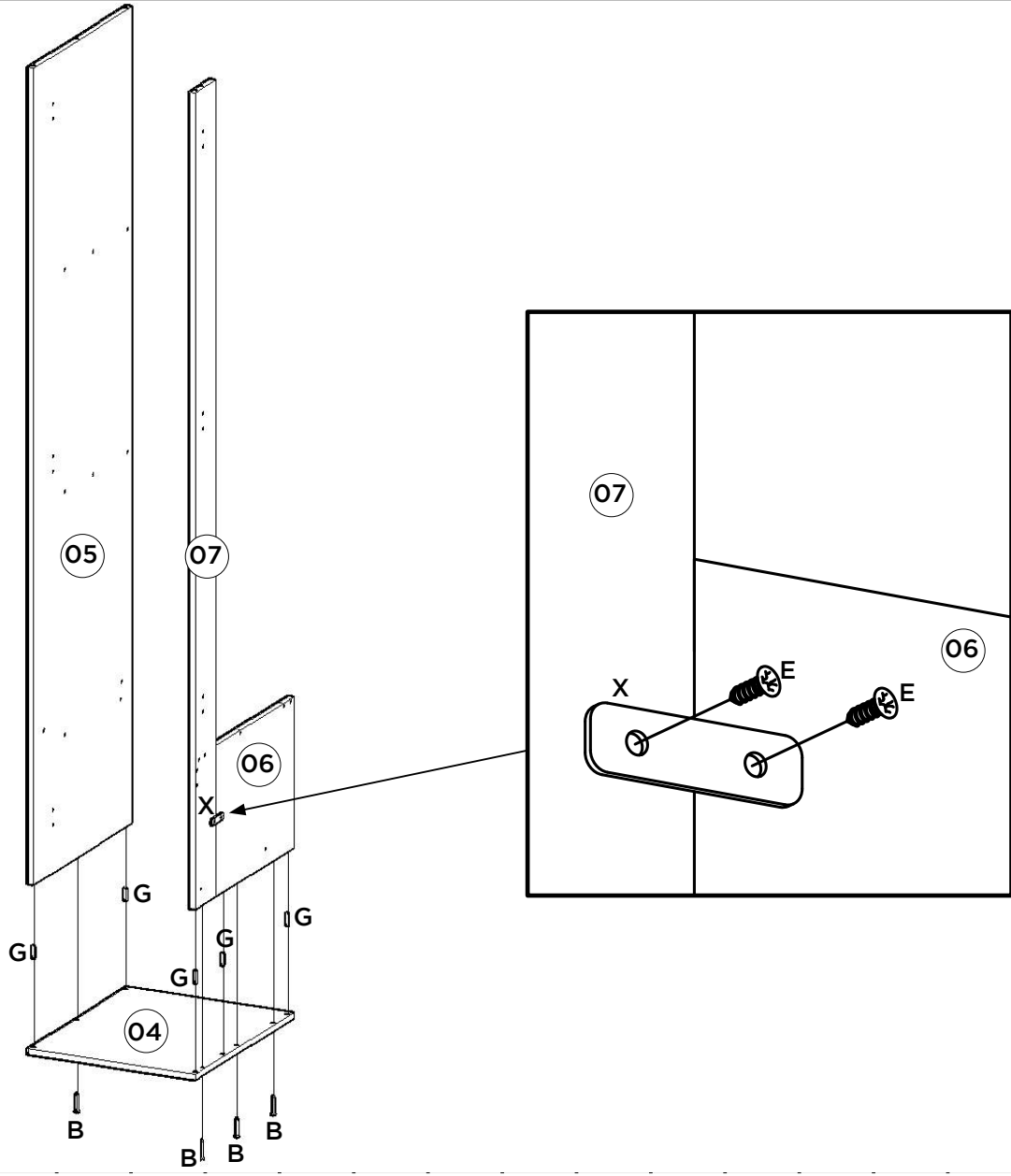

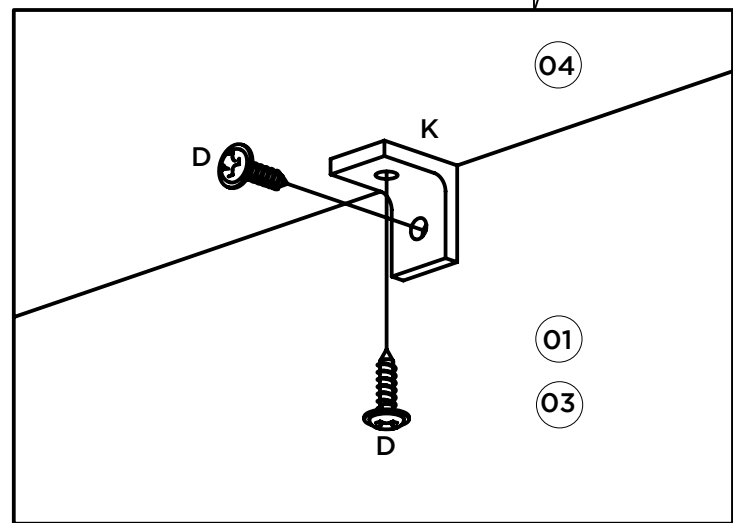
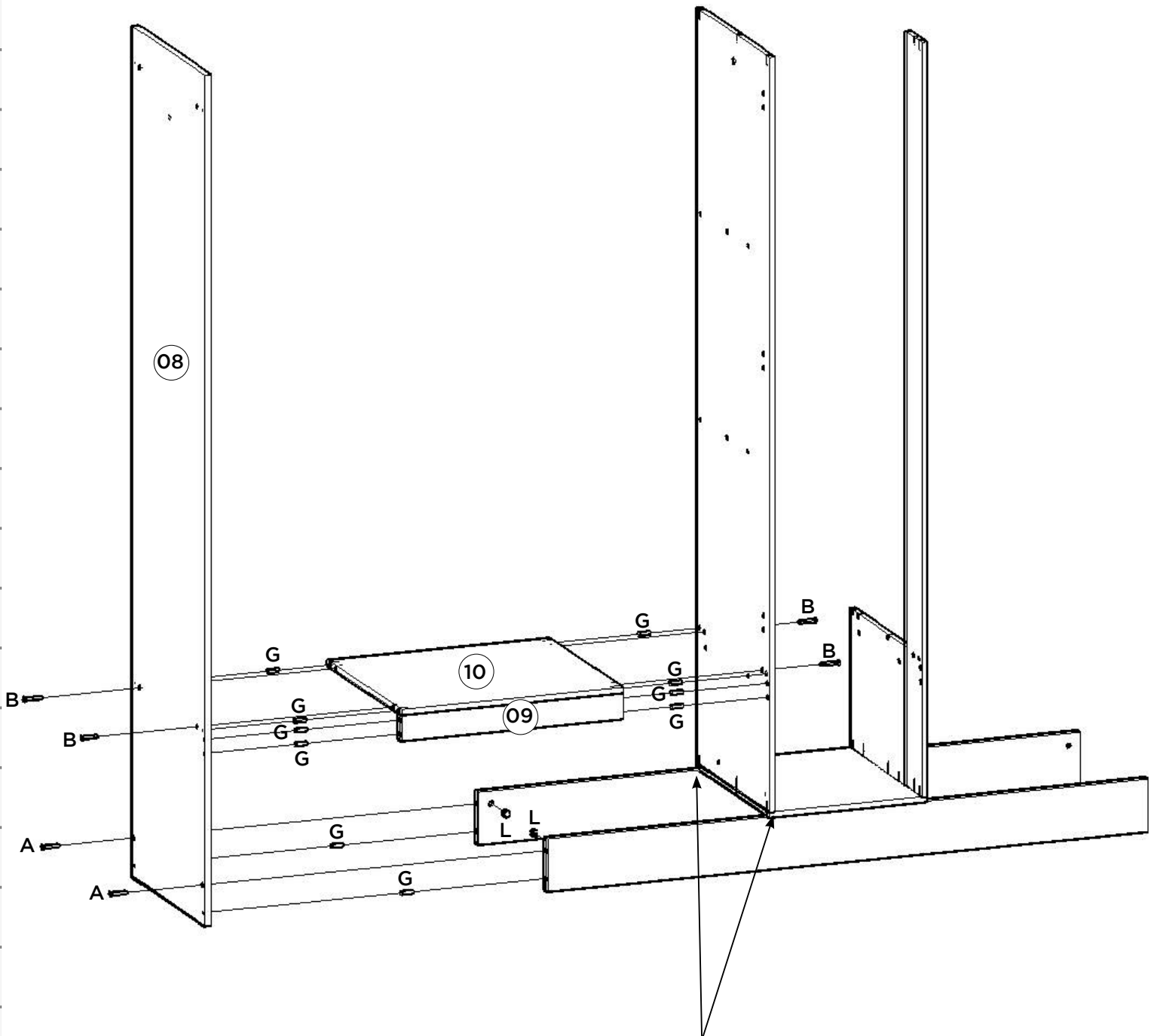

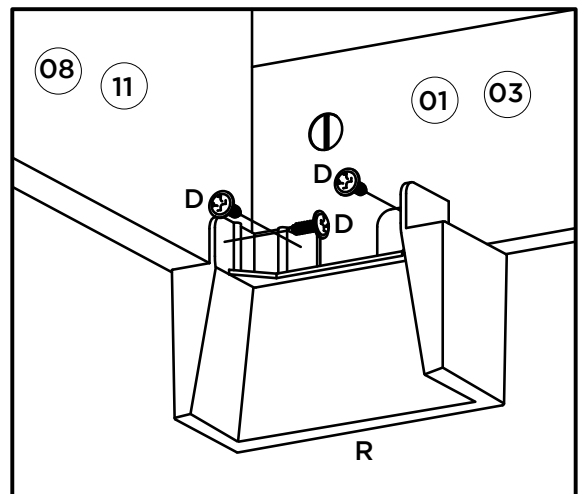
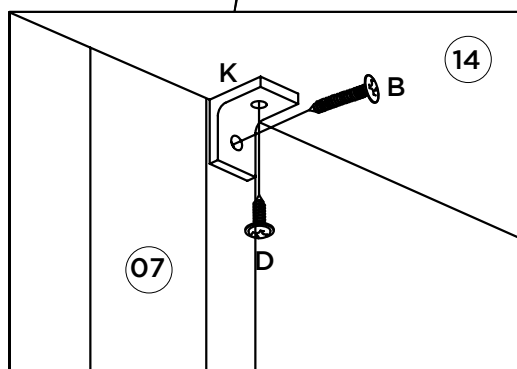
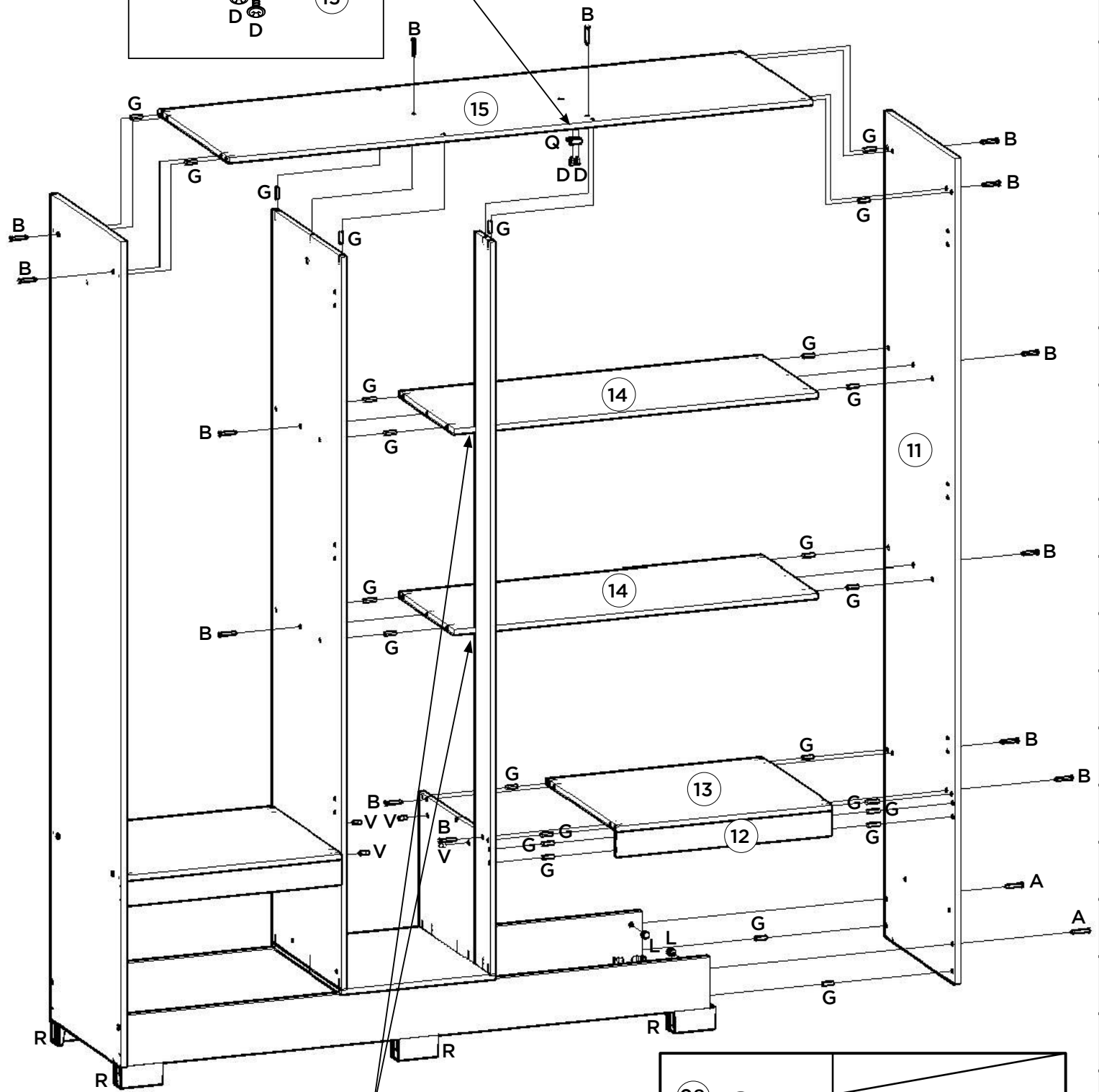
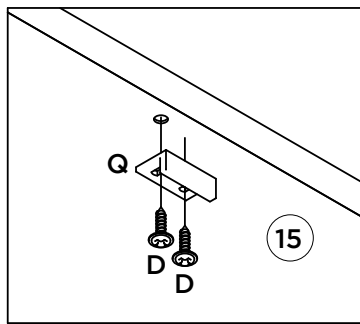

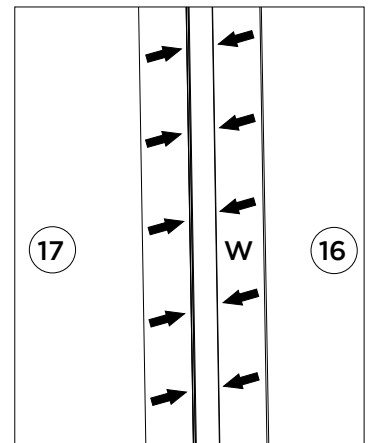
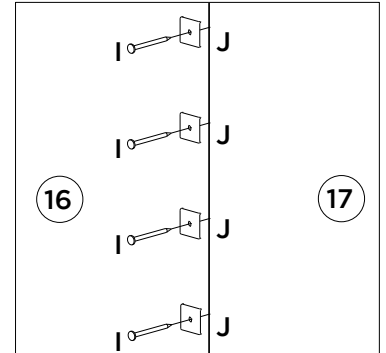
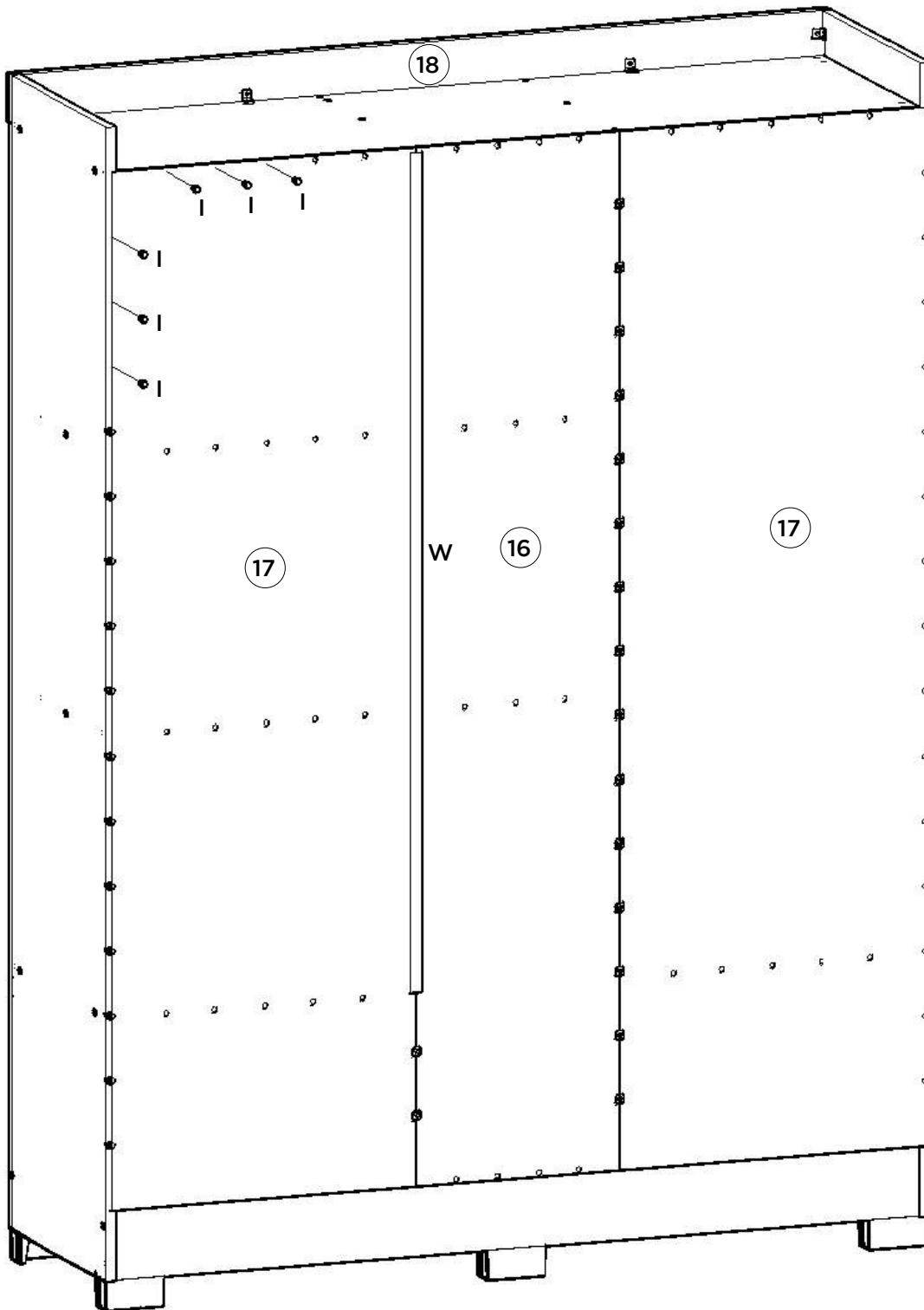
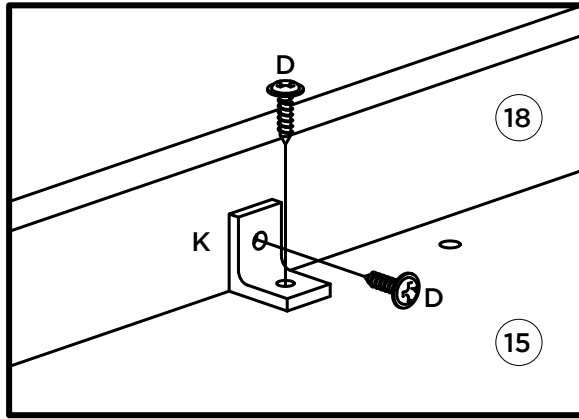

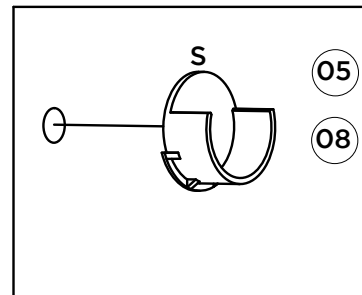
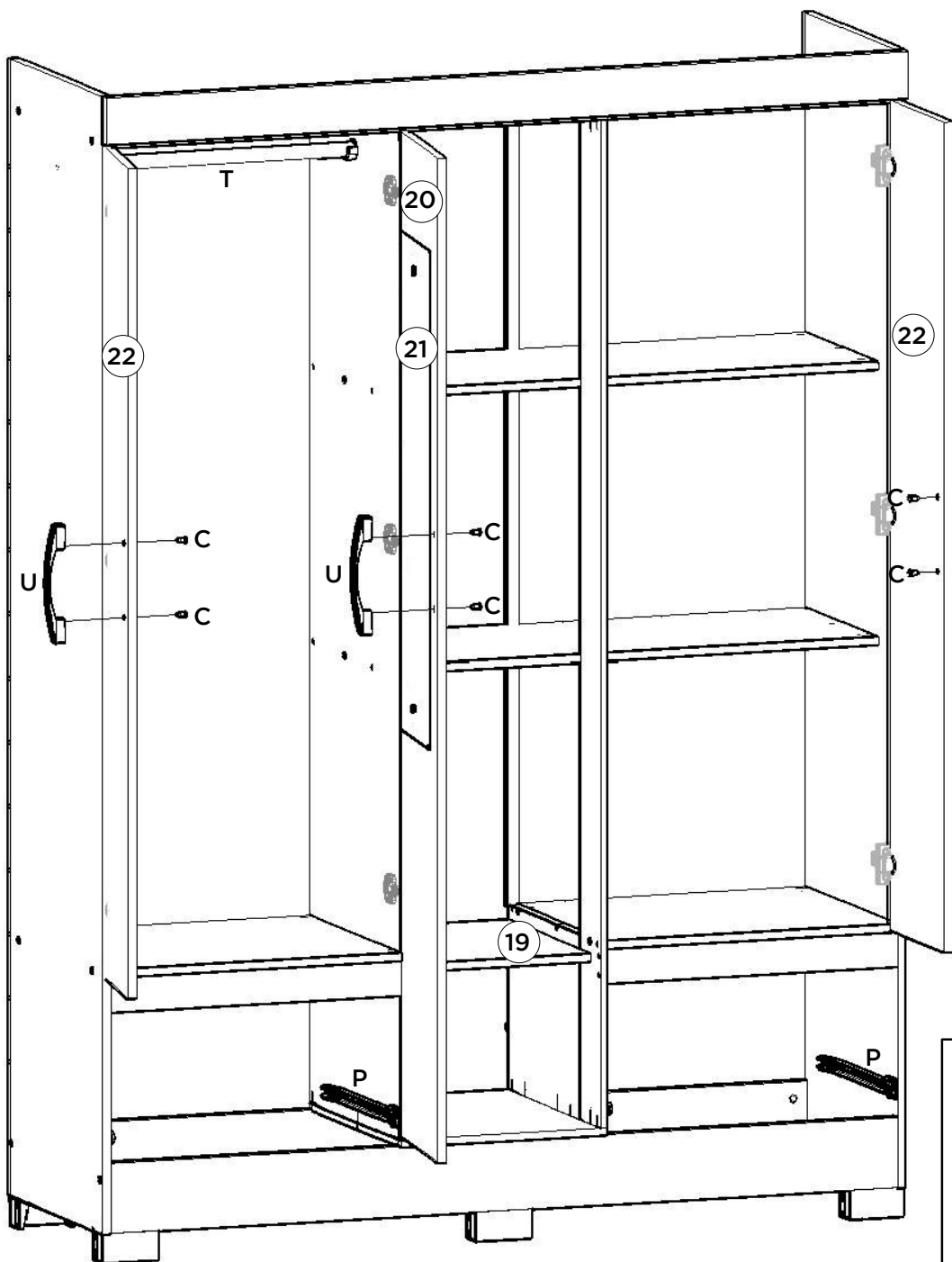

Vídeo: Instalar e regular Dobradiças

Vídeo: Instale y ajuste las bisagras

Vídeo: Install and adjust hinges

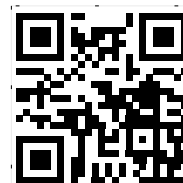

Vídeo: Dicas para instalar corredeira

Vídeo: consejos para instalar la diapositiva

Vídeo: Tips for installing slide

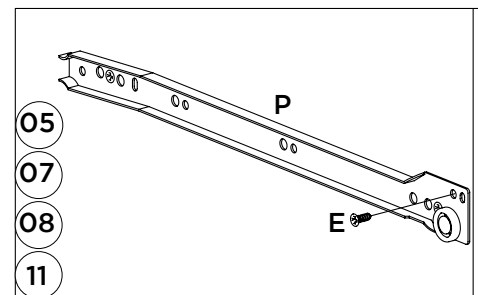
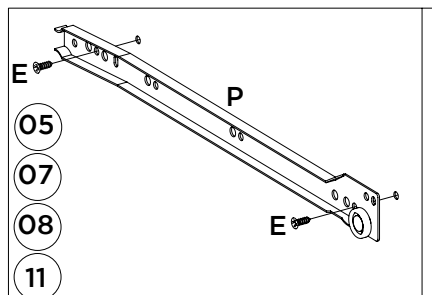
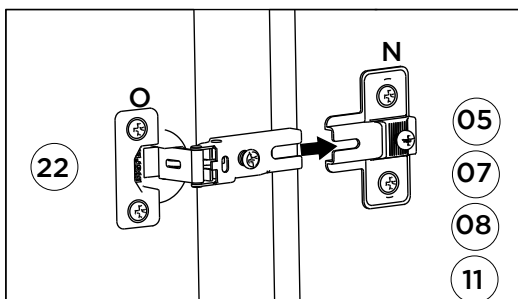
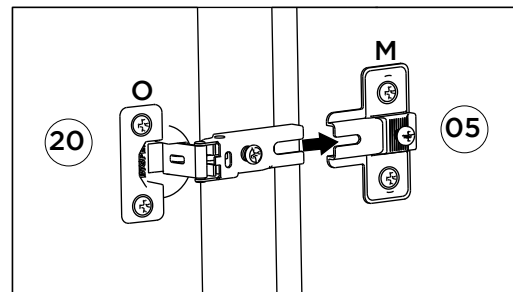
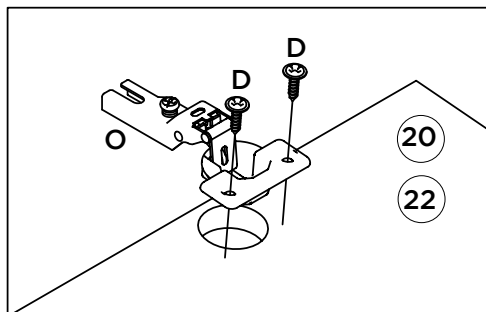
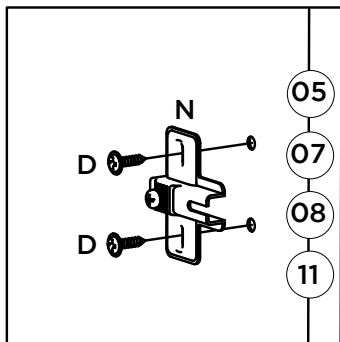
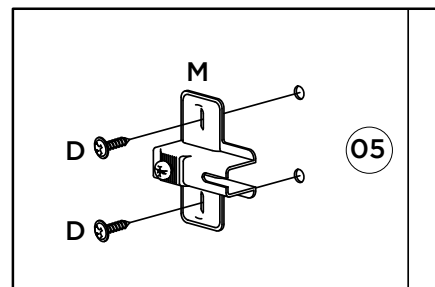

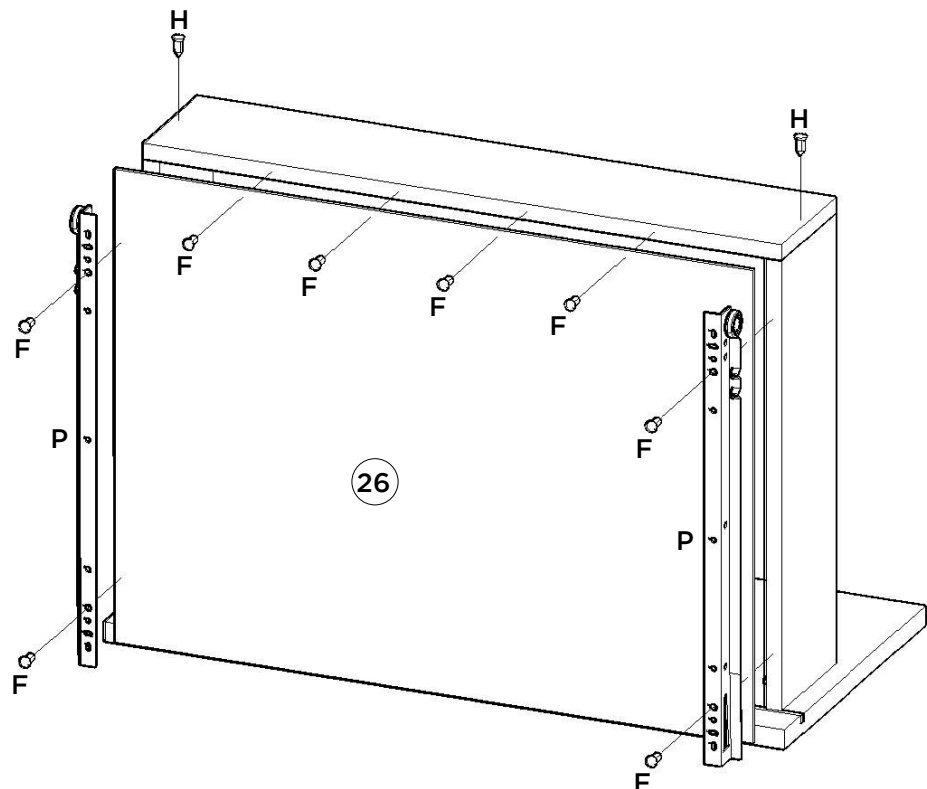
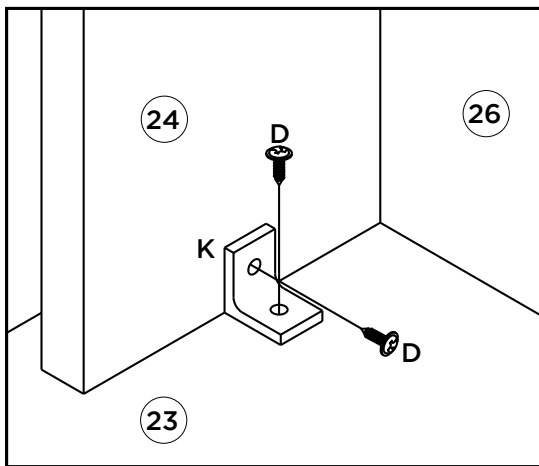
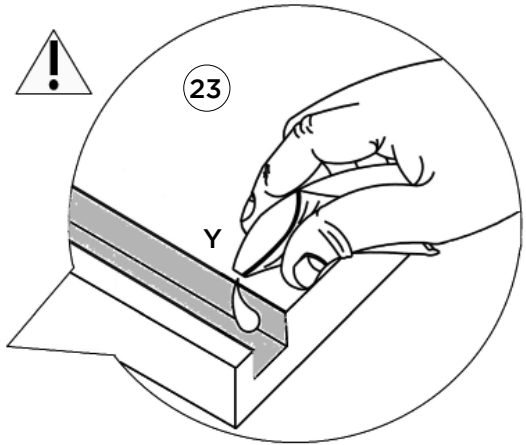
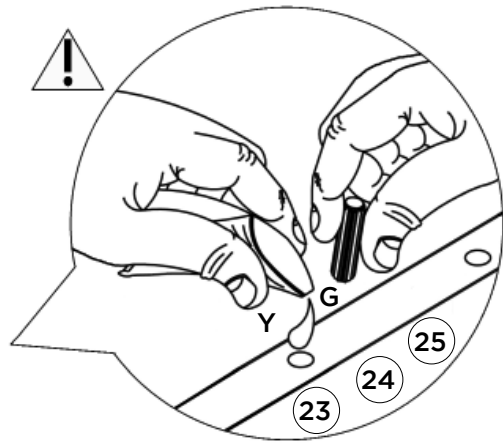
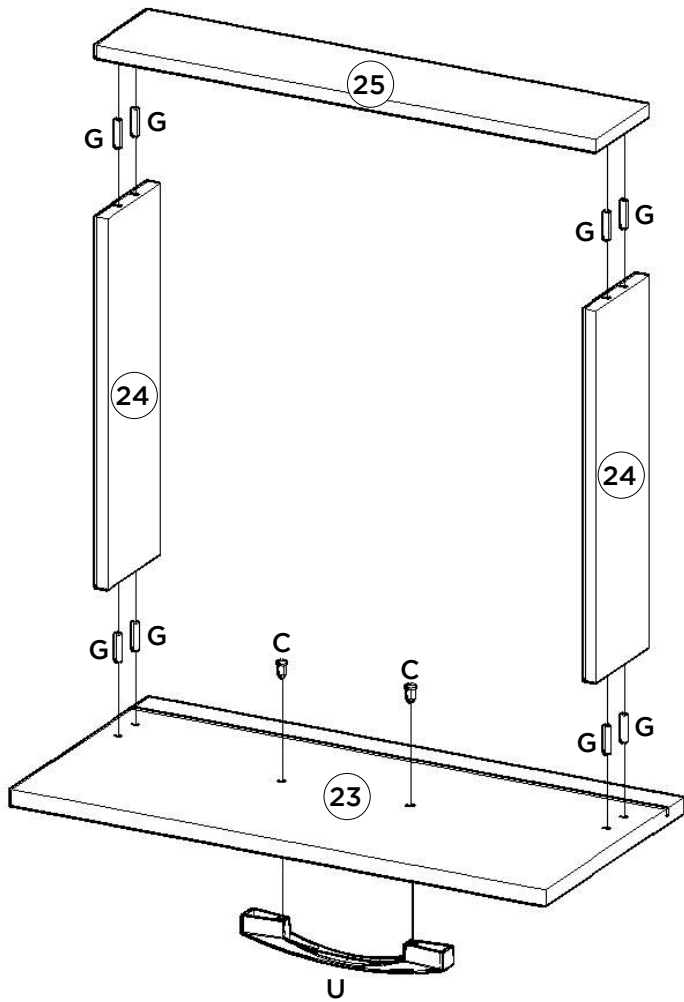









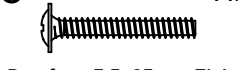

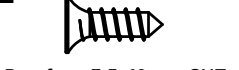



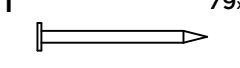





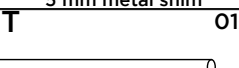
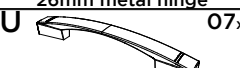

Lista de Peças | Lista de piezas | List of parts

Item	Caixa Caja Box	Qtd Ctd Qty	Descrição Descripción Description	Medidas (mm) Dimensions (mm) Size (measurements) (mm)
01	1/2	01	Rodapé Frontal Pie de página Front Footer	1424x120x12
02	1/2	01	Travessa do Rodapé Carril pie Baseboard crosspiece	415x120x12
03	1/2	01	Rodapé Traseiro pie de página trasera Rear Footer	1424x120x12
04	1/2	01	Base Base Base	445x374x12
05	1/2	01	Divisão esquerda División izquierda Left Division	1730x445x12
06	1/2	01	Divisão gaveta direita División cajón derecho Right drawer partition	350x320x12
07	1/2	01	Pilastra Pilas Pilaster	1730x95x12
08	1/2	01	Lateral esquerda Lateral izquierda Left side	1950x445x12
09=12	2/2	01	Travessa Frontal Travessa Frontal Front cross member	525x60x12
10=13	1/2	01	Tampo da Gaveta Tablero de la Cajón Drawer Top	525x445x12
11	1/2	01	Lateral direita Lateral derecha Right side	1950x445x12
12=09	2/2	01	Travessa Frontal Travessa Frontal Front cross member	525x60x12
13=10	1/2	01	Tampo da Gaveta Tablero de la Cajón Drawer Top	525x445x12
14	1/2	02	Prateleira Maior Estantería Mayor Largest Shelf	887x350x12
15	1/2	01	Tampo Superior Tapa superior Top panel	1424x445x12
16	1/2	01	Fundo Fondo Bottom	1754x362x3
17	2/2	02	Fundo Maior Fondo Mayor Greater Fund	1754x539x3
18	2/2	01	Chapéu Sombrero Hat	1446x80x15
19	1/2	01	Prateleira Central Estantería central Central Shelf	400x350x12
20	2/2	01	Porta Espelho Puerta Espejo Mirror Door	1722x344x15
21	2/2	01	Espelho com furo Espejo con orificio Mirror with hole	850x220x3
22	2/2	04	Porta Puerta Door	1423x265x15
23	2/2	02	Frente de gaveta Frente de cajón Front of drawer	533x260x15
24	1/2	04	Lado de gaveta Lado del cajón Side of drawer	350x100x12
25	1/2	02	Ripa de trás Malla detrás Rear lath	500x100x12
26	1/2	02	Fundo de gaveta Fondo de cajón Drawer bottom	499x367x3

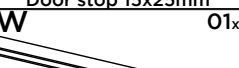
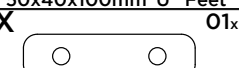
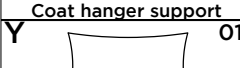
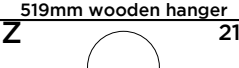
Ferragens | Herrajes | Hardware

A  Parafuso 4,5x50mm CHT. Tornillo 4,5x50mm CHT. Screw 4,5x50mm CHT.	B  Parafuso 3,5x40mm CHT. Tornillo 3,5x40mm CHT. Screw 3,5x40mm CHT.	C  Parafuso 3,5x25mm FLA. Tornillo 3,5x25mm FLA. Screw 3,5x25mm FLA.	D  Parafuso 3,5x12mm FLA. Tornillo 3,5x12mm FLA. Screw 3,5x12mm FLA.	E  Parafuso 3,5x12mm CHT. Tornillo 3,5x12mm CHT. Screw 3,5x12mm CHT.	F  Parafuso 3,0x16mm CHT. Tornillo 3,0x16mm CHT. Screw 3,0x16mm CHT.
G  Cavilha 5x25mm Cinta 5x25mm Dowel 5x25mm	H  Prego 12x12mm Anelado Clavo 12x12mm Anillado Ringed Nails 12x12mm	I  Prego 10x10mm Clavo 10x10mm Nail 10x10mm	J  Fixador de fundos Fijador de fondos Bottom fixer	K  Cantoneira plástica Cantonera plástica Plastic angle brackets	L  Porca Cilíndrica Tuerca cilíndrica Cylindrical nut
M  Calço metal 12mm Calzado metálico 12mm 12 mm metal shim	N  Calço metal 5mm Calzado metálico 5mm 5 mm metal shim	O  Dobradiça metal 26mm Bisagra de metal 26mm 26mm metal hinge	P  Corrediça metal 350mm Corredera de metal 350mm Sliding metal 350mm	Q  Batente 15x25mm Aldaba 15x25mm Door stop 15x25mm	R  Pé "U" 50x40x100mm Pie "U" 50x40x100mm 50x40x100mm"U" Feet
S  Suporte cabideiro Soporte de percha Coat hanger support	T  Cabideiro Madeira 519mm Cabezal Madera 519mm 519mm wooden hanger	U  Puxador Indonésia 128mm Tirador Indonesia 128mm 128mm Indonesia handle	V  Suporte prateleira Soporte estante Shelf Support	W  Perfil "I" 1418mm Perfil "I" 1418mm Profile "I" 1418mm	X  Suporte de Metal Soporte de Metal Metal stands
Y  Sachê de cola Bolsa de pegamento Glue bag	Z  Adesivo tapa parafuso 10mm Adhesivo tapón de tornillo 10mm Bolt cover adhesive 10mm	AA  Etiqueta resinada Briz Etiqueta resinada Briz Briz resin label			