

# HENN

Ind. e Com. de Móveis Henn  
Mondaí - SC - Brasil

+55 49 3674.3500

@moveishenn  
www.henn.com.br

## INSTRUÇÕES DE MONTAGEM

INSTRUCCIONES DE MONTAJE  
ASSEMBLY INSTRUCTIONS

### Roupeiro Verg 02 Portas | Armario Verg 02 Puertas | Wardrobe Verg 02 Doors

- D239-127 Nature/Off White
- D239-130 Castanho HP

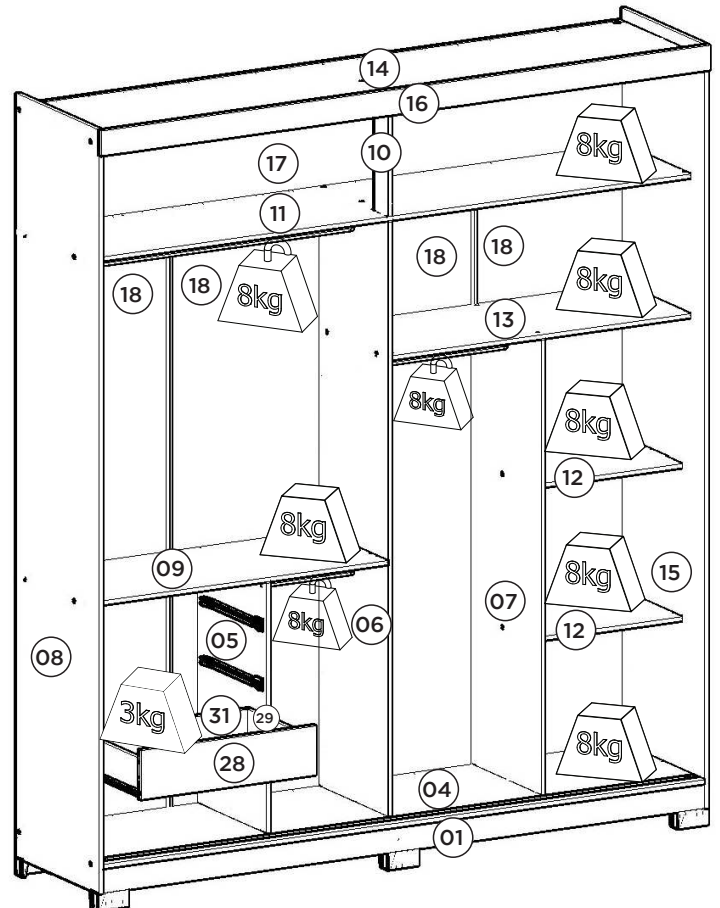
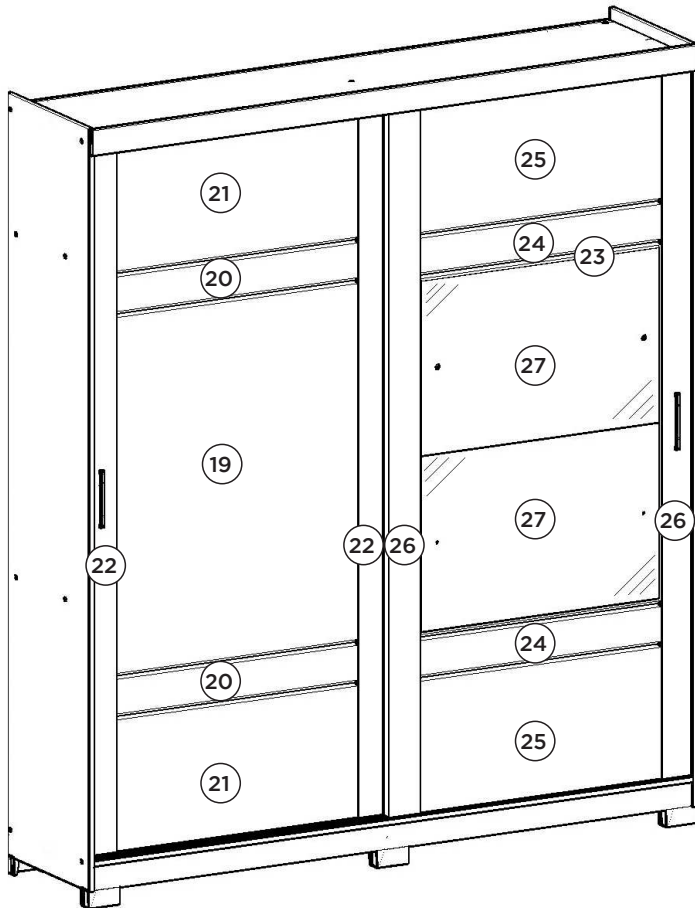

#### Requisitos para montagem Requisitor para la montaje Assembly Requirements

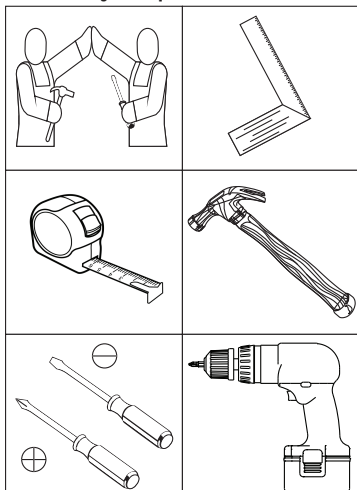

Imagens meramente ilustrativas  
Imágenes meramente ilustrativas  
Images for illustration only

#### Pesos máximos recomendados com carga distribuída Peso máximo recomendado con la carga distribuida Recommended maximum weights with evenly distributed.

##### AVISO

Para limpeza de seu móvel, use uma flanela seca ou umedecida, e não utilize produtos químicos que possam danificar seu produto.

##### SISTEMA DE MONTAGEM

O sistema de montagem dos produtos, funciona de acordo com a ordem crescente dos números indicados no desenho. Ex: 01, 02, 03, 04... até a conclusão da montagem.

##### ADVERTENCIA

Para limpieza de su móvil, use una franela seca o húmeda, y no utilice productos químicos que puedan dañar su producto.

##### SISTEMA DE MONTAJE

El sistema de montaje de los productos funciona de acuerdo con el orden creciente de los números indicados en el dibujo. Ej.: 01, 02, 03, 04... hasta la conclusión del montaje.

##### NOTICE

To clean your furniture, use a dry or wet cloth, and do not use chemicals that may damage your product.

##### ASSEMBLY SYSTEM

The products' assembly system works according to the increasing order of the indicated numbers. For example: 01, 02, 03, 04 ... to the end of the assembly.

1°

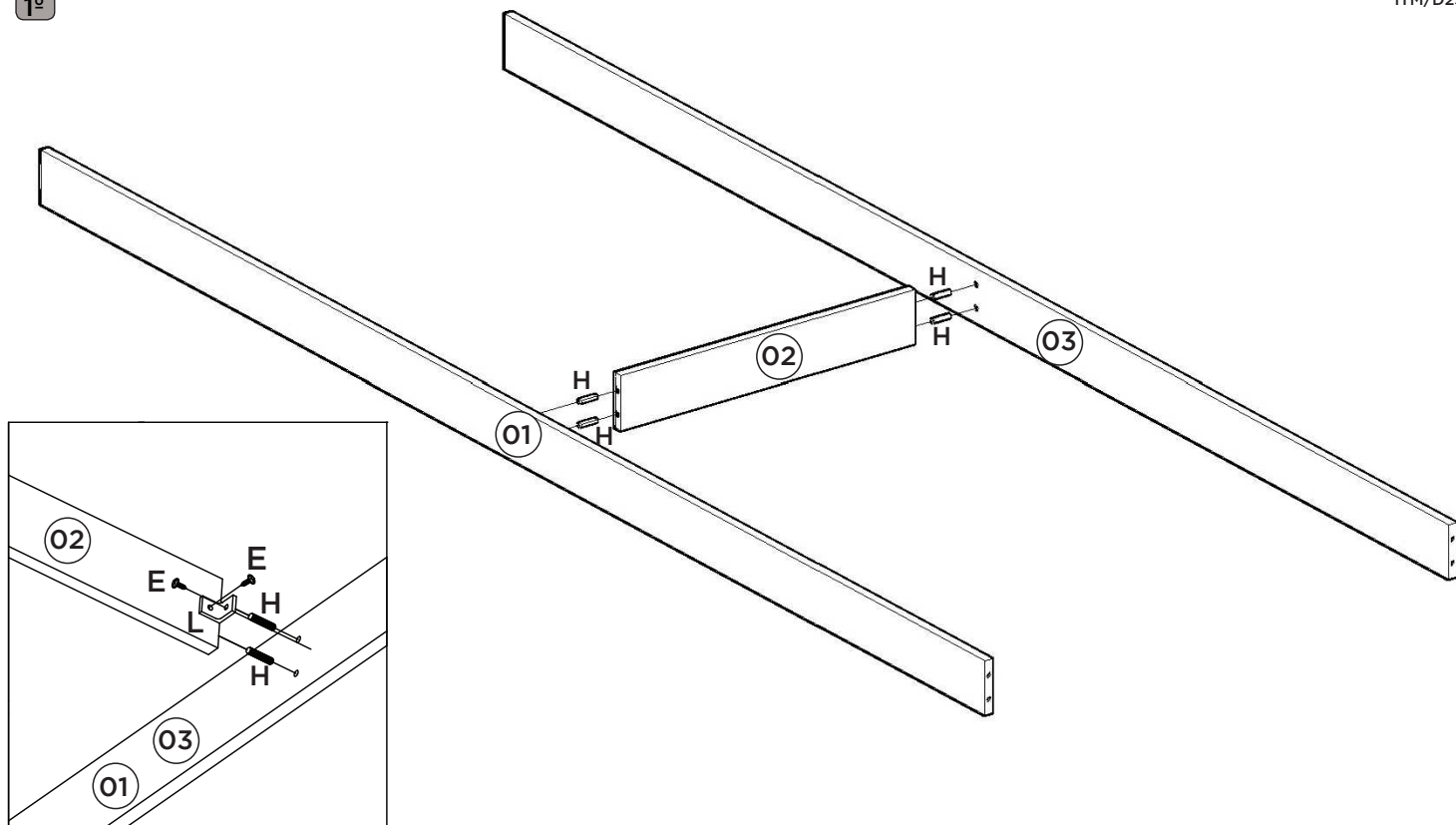

2°

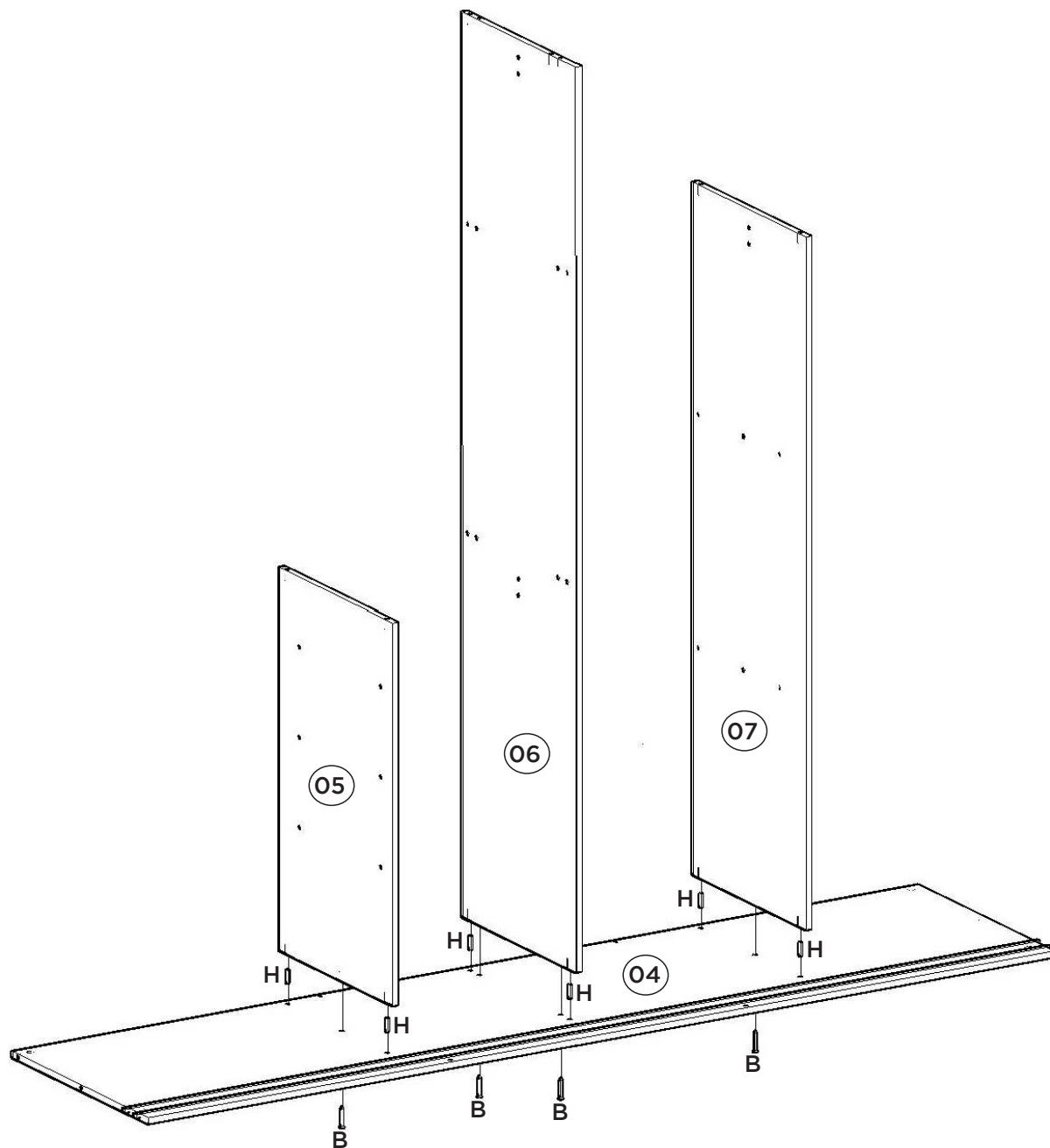

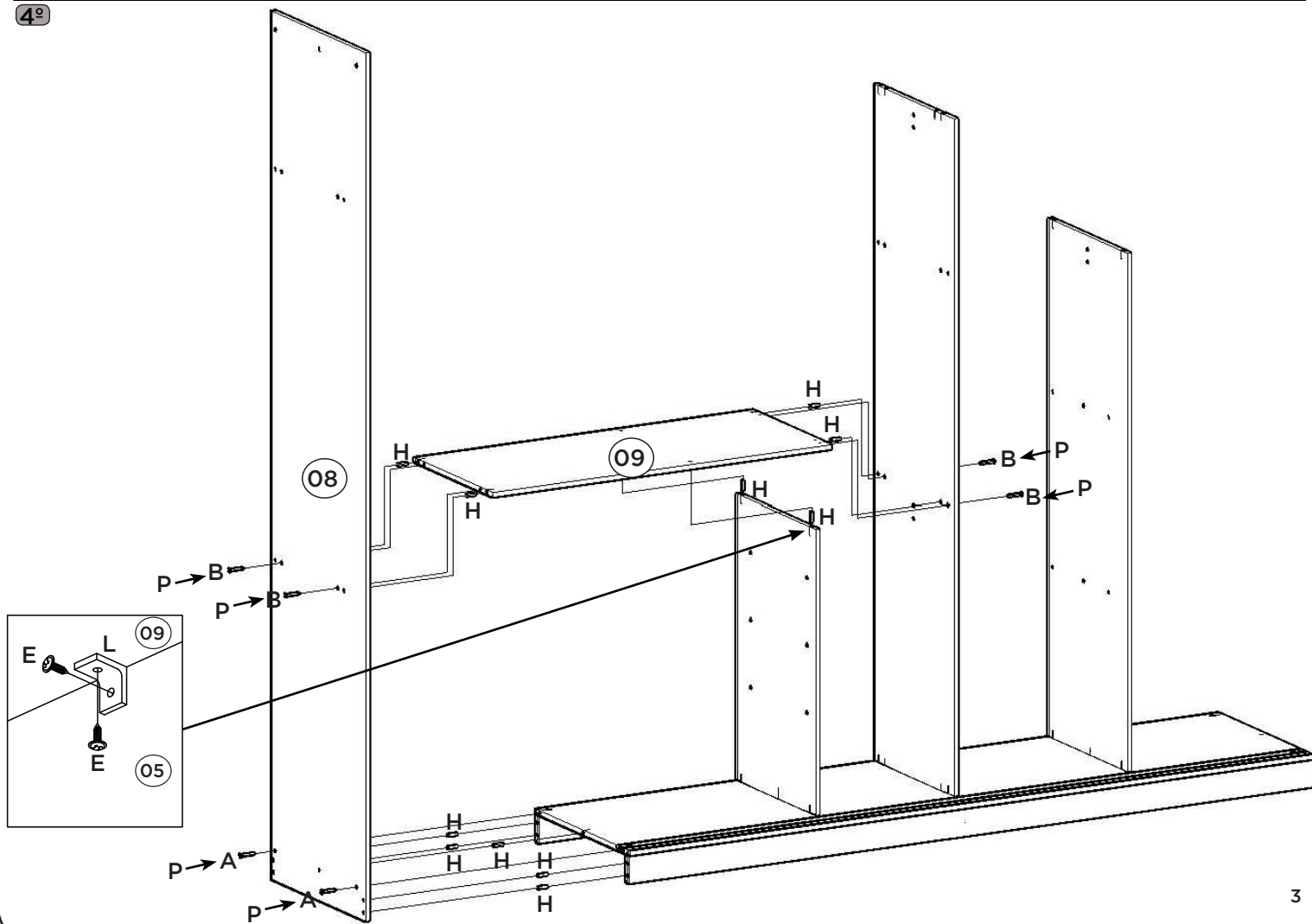
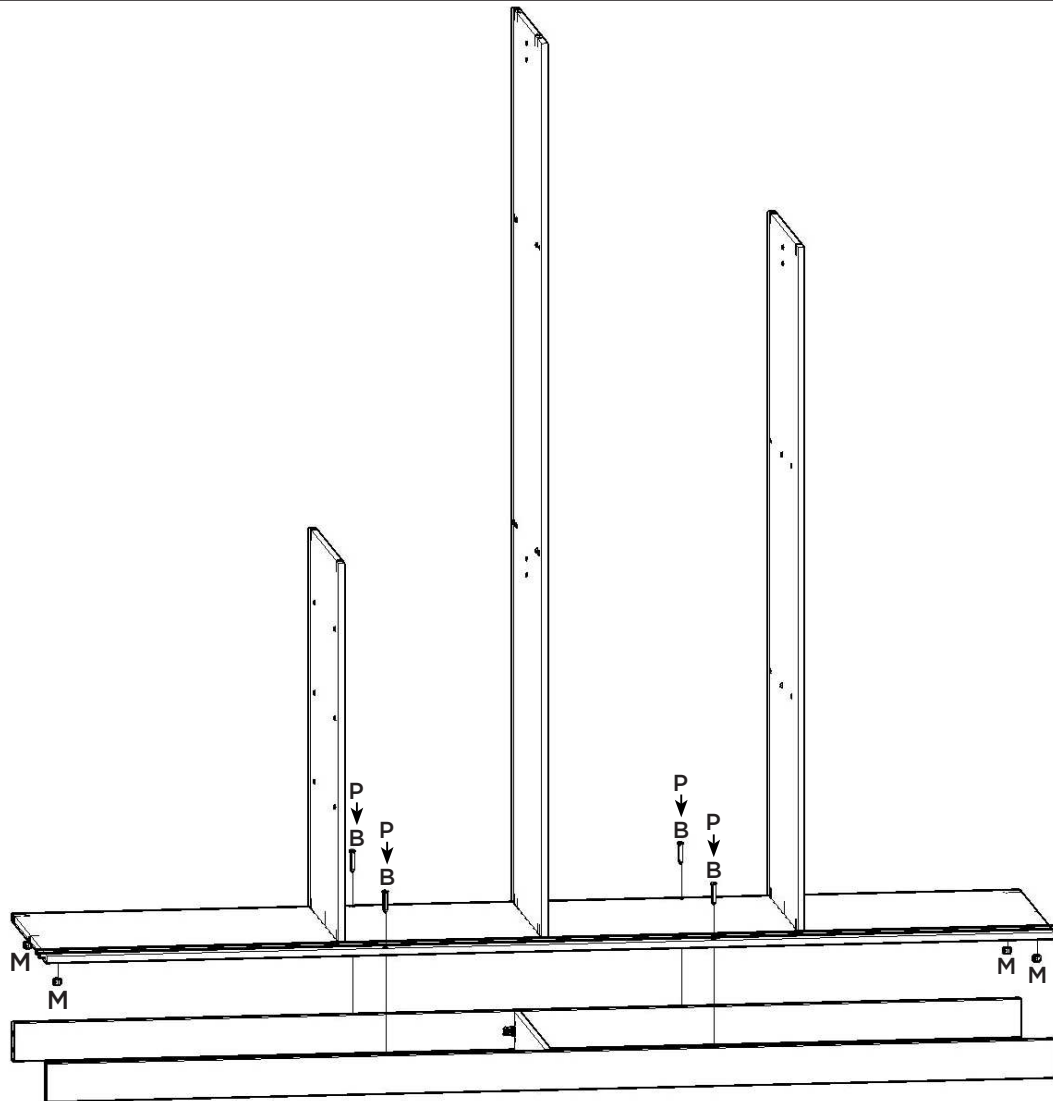

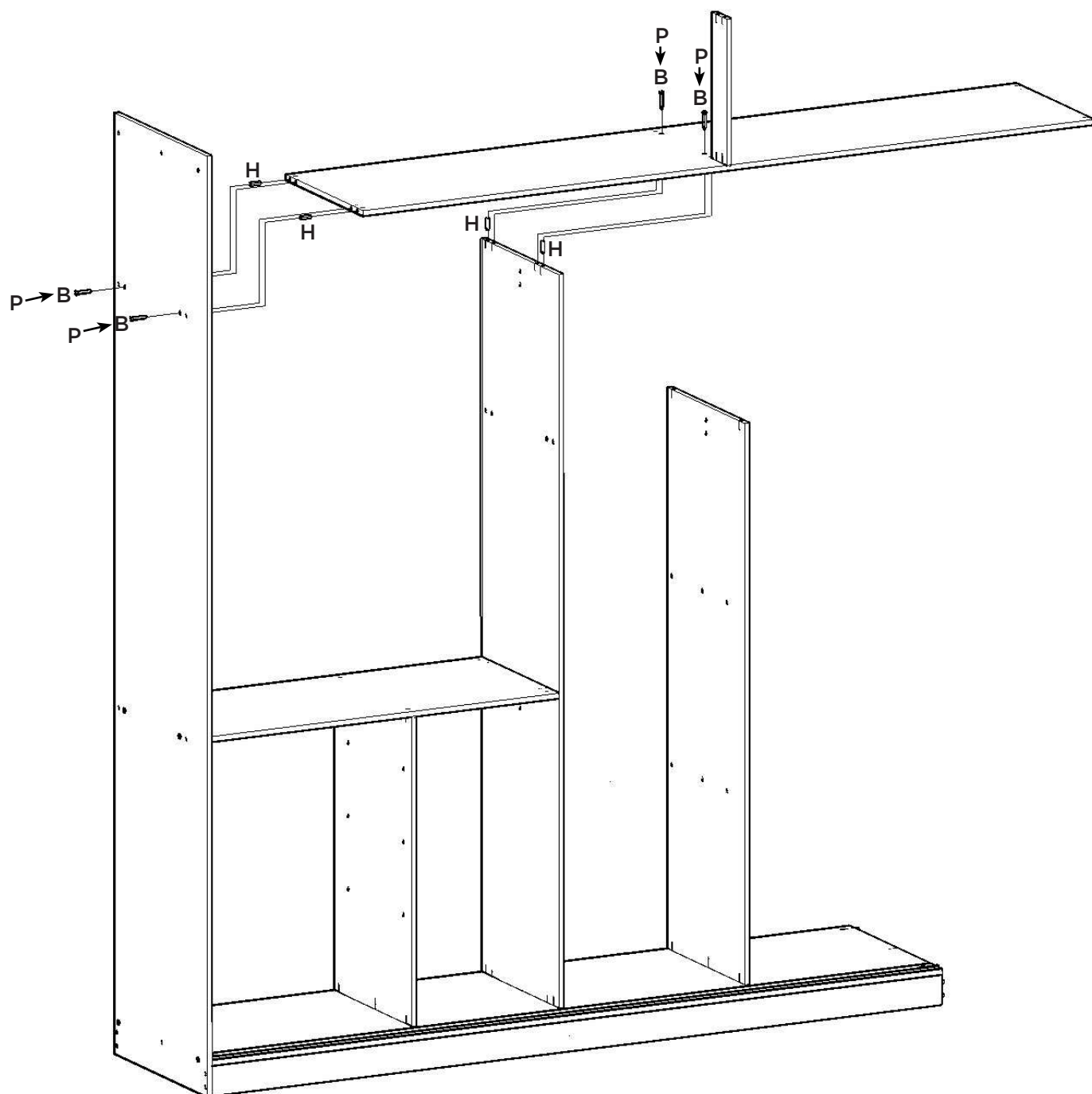
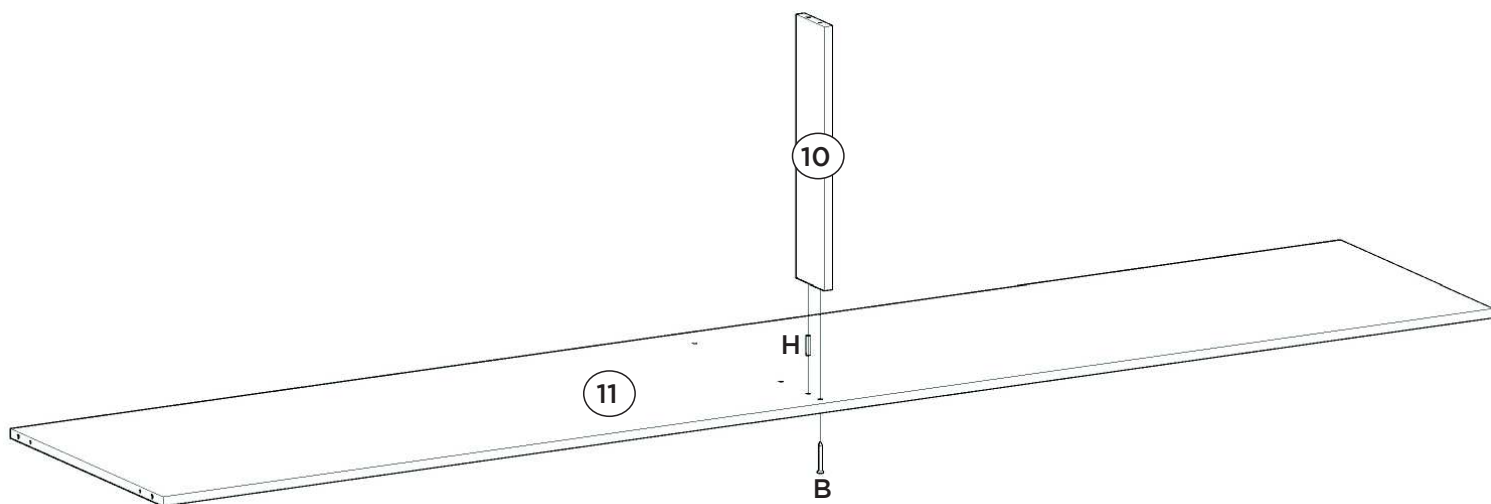

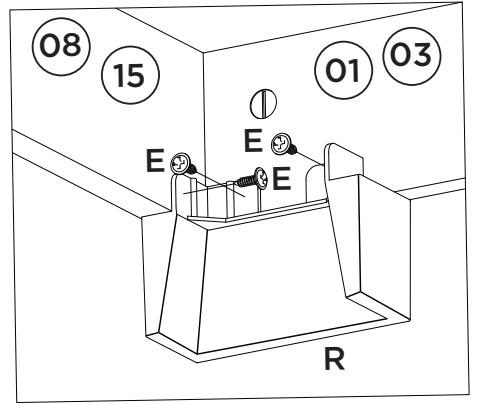
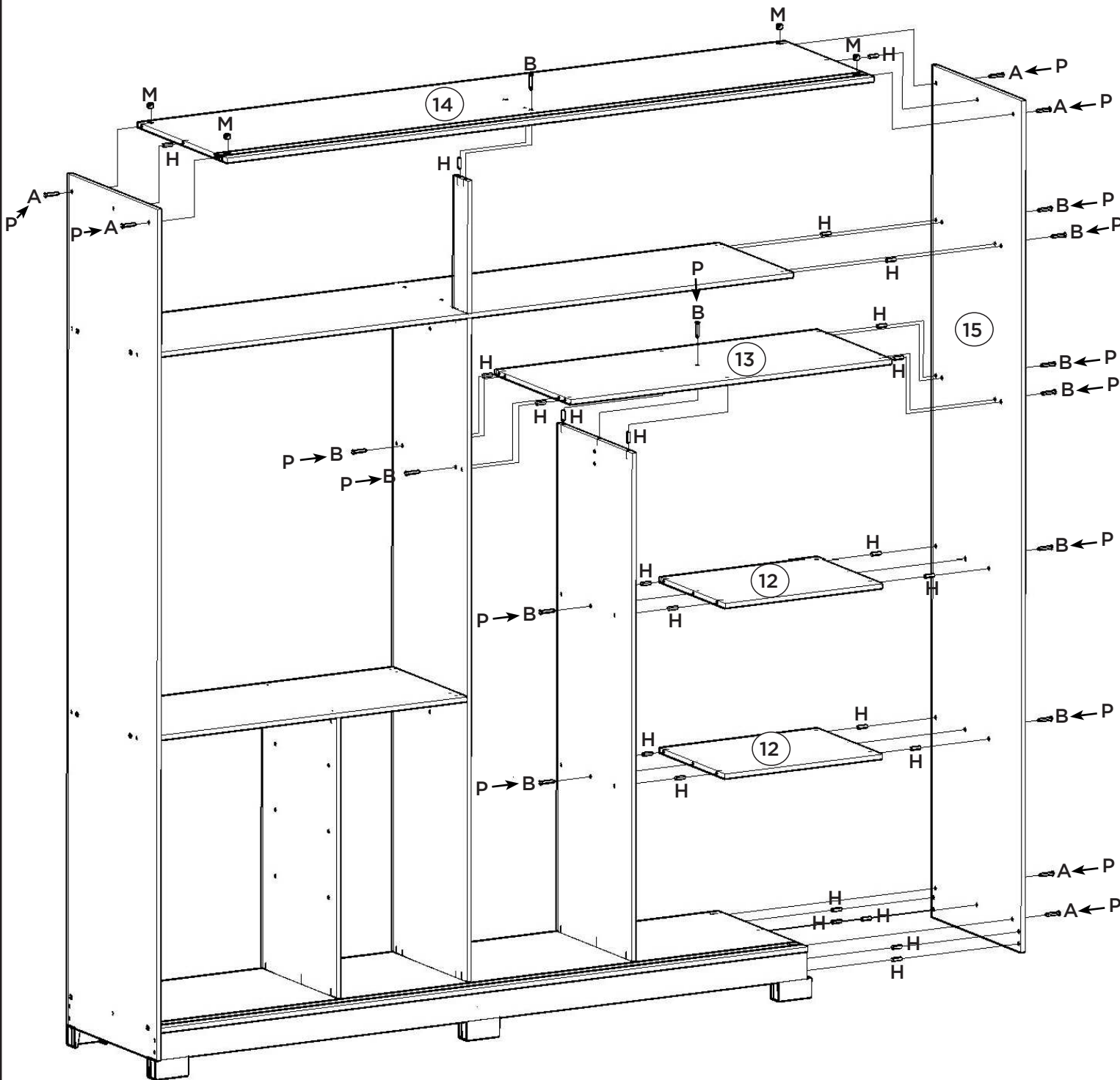

Fixar os pregos a uma distância de 120mm de um para outro.

Fijar las uñas a un distancia de 120 mm uno a otro.

Fix the nails at a distance of 120mm from one to the other

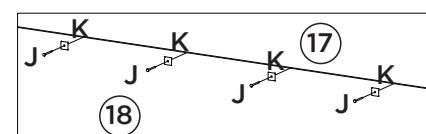
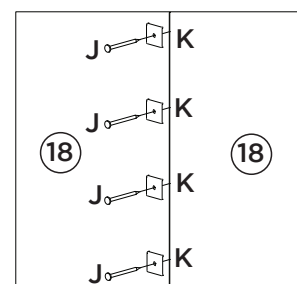
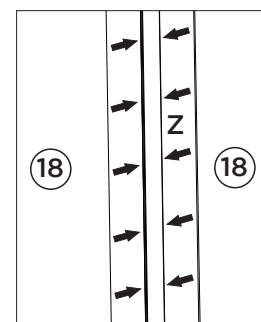
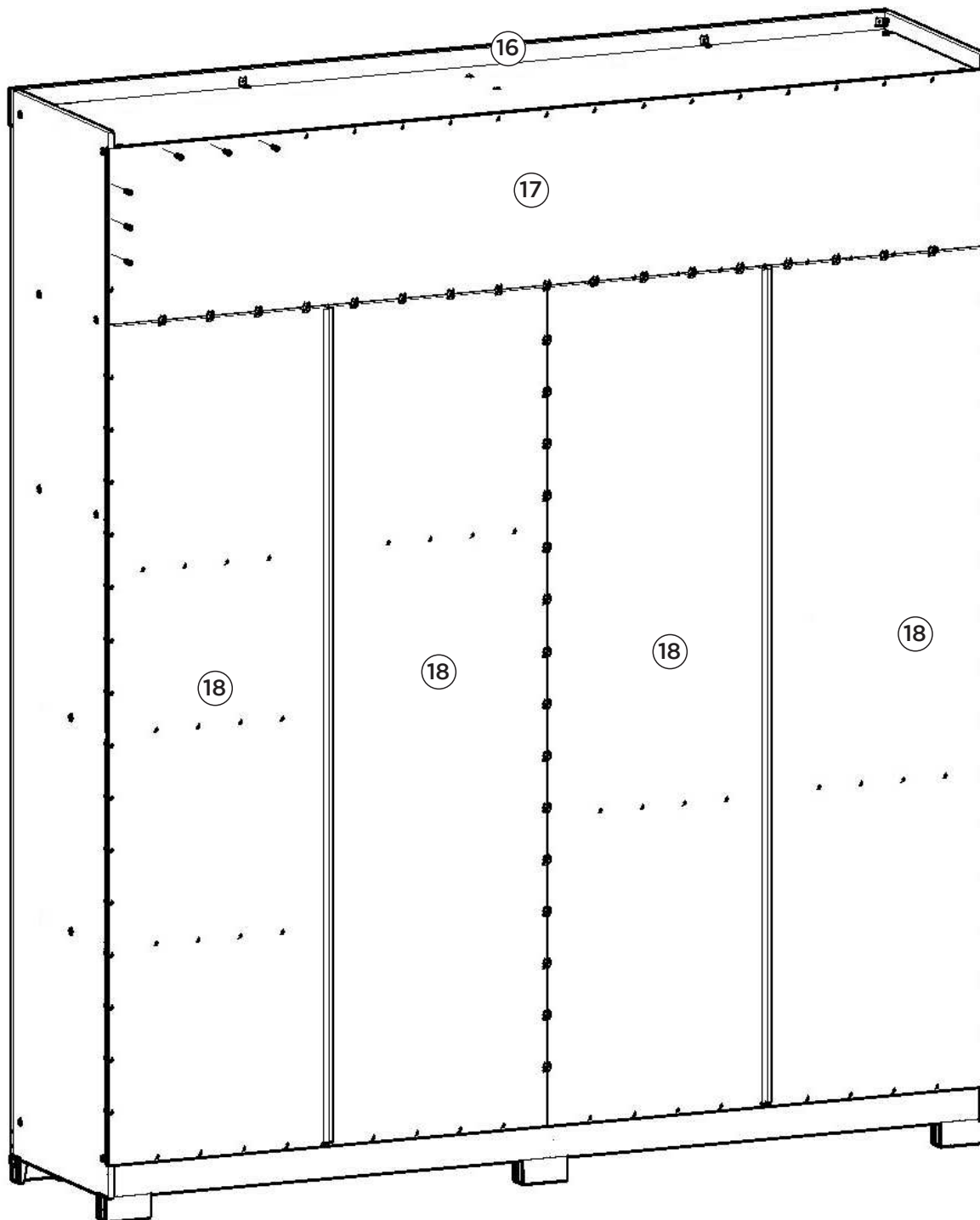
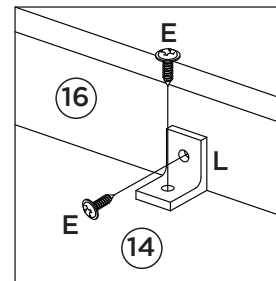

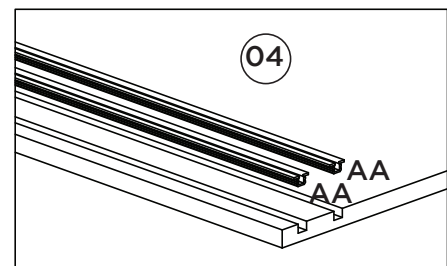
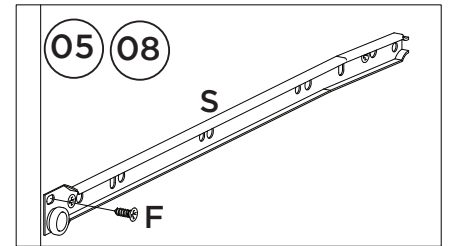
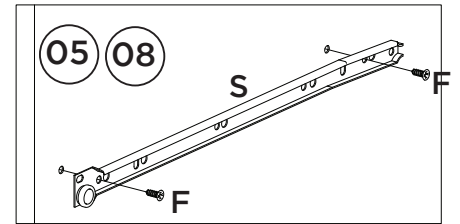
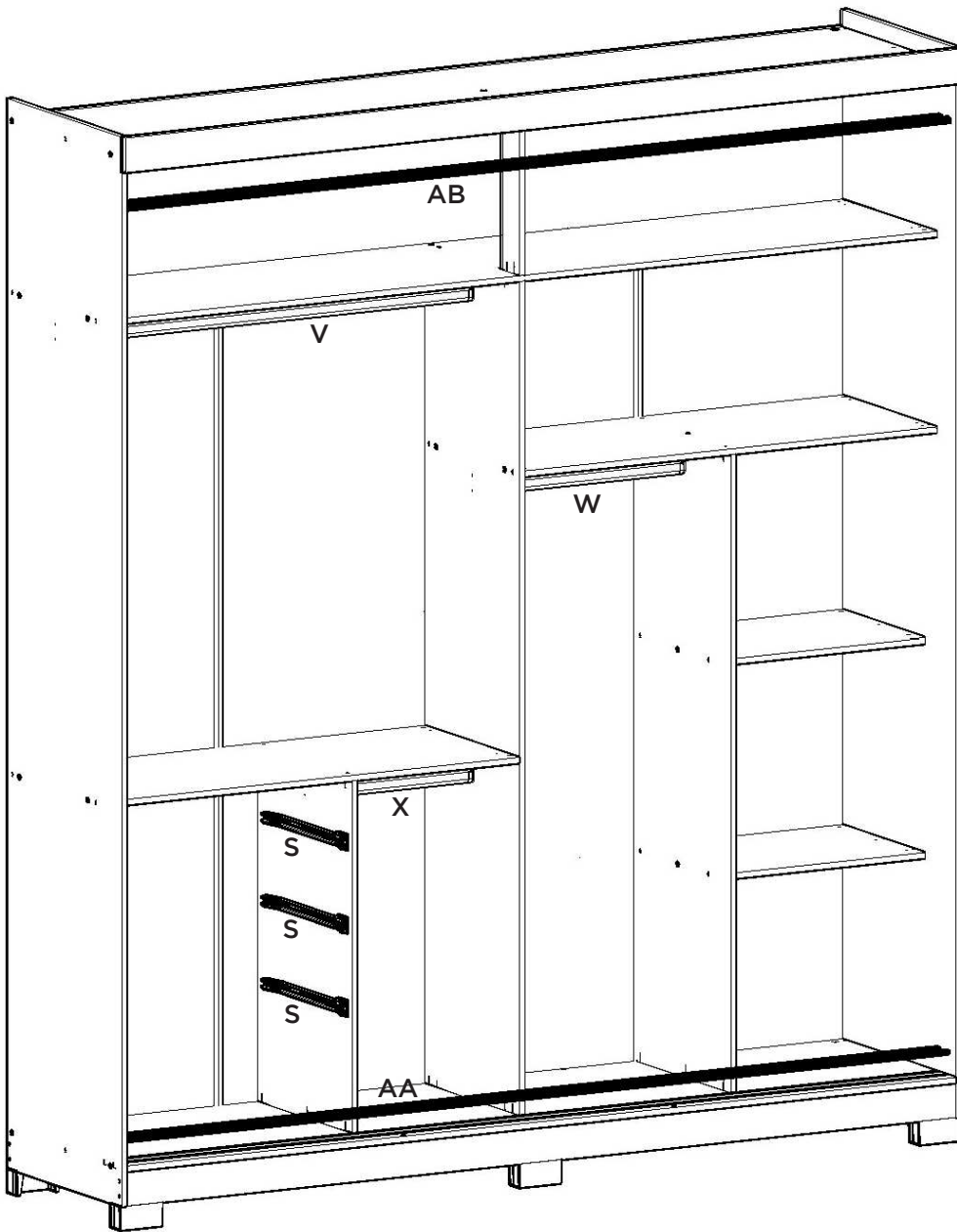
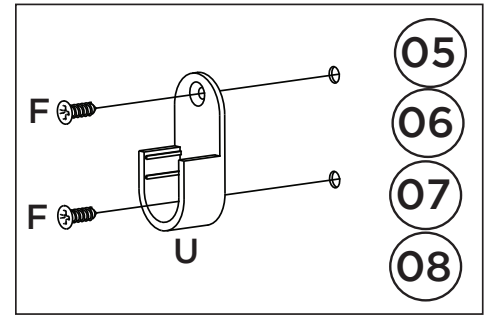
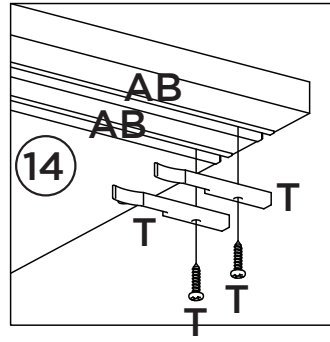
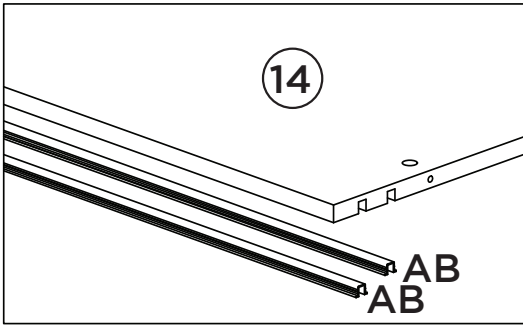

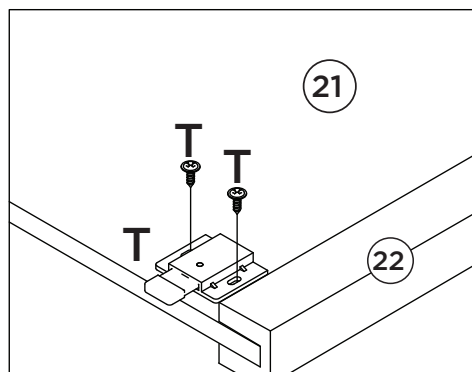
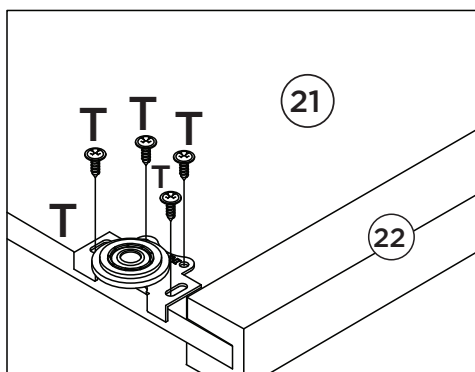
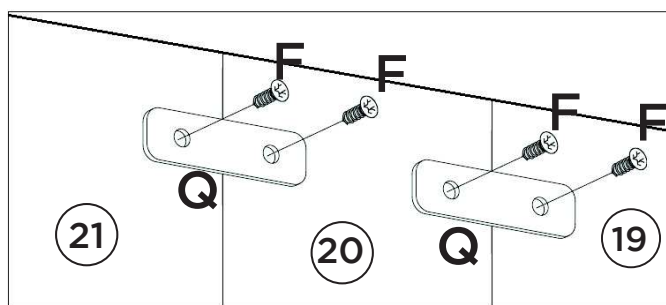
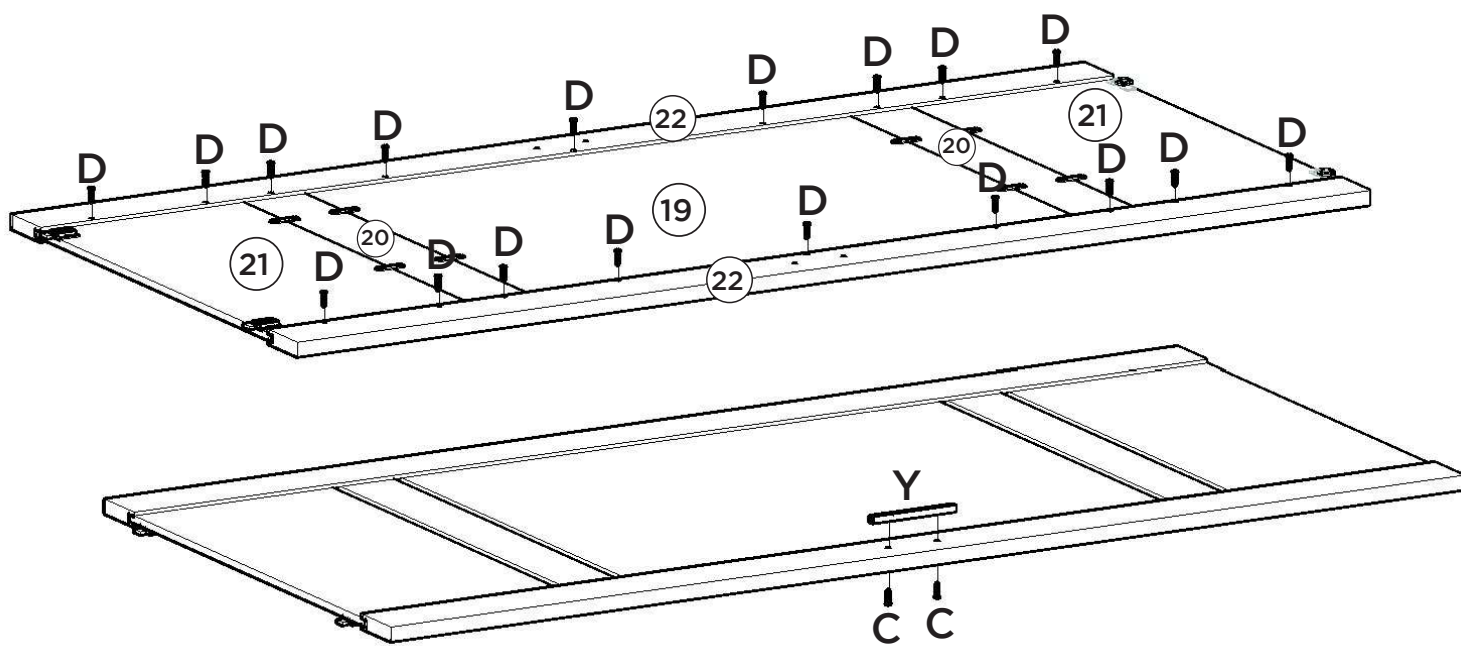



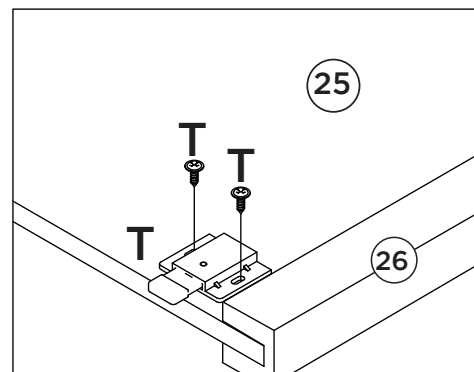
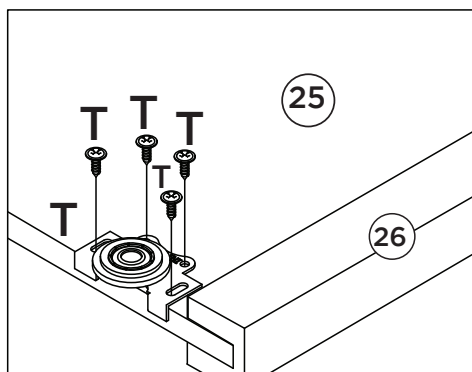
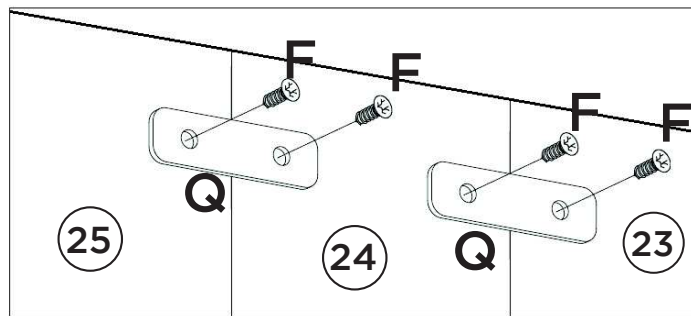
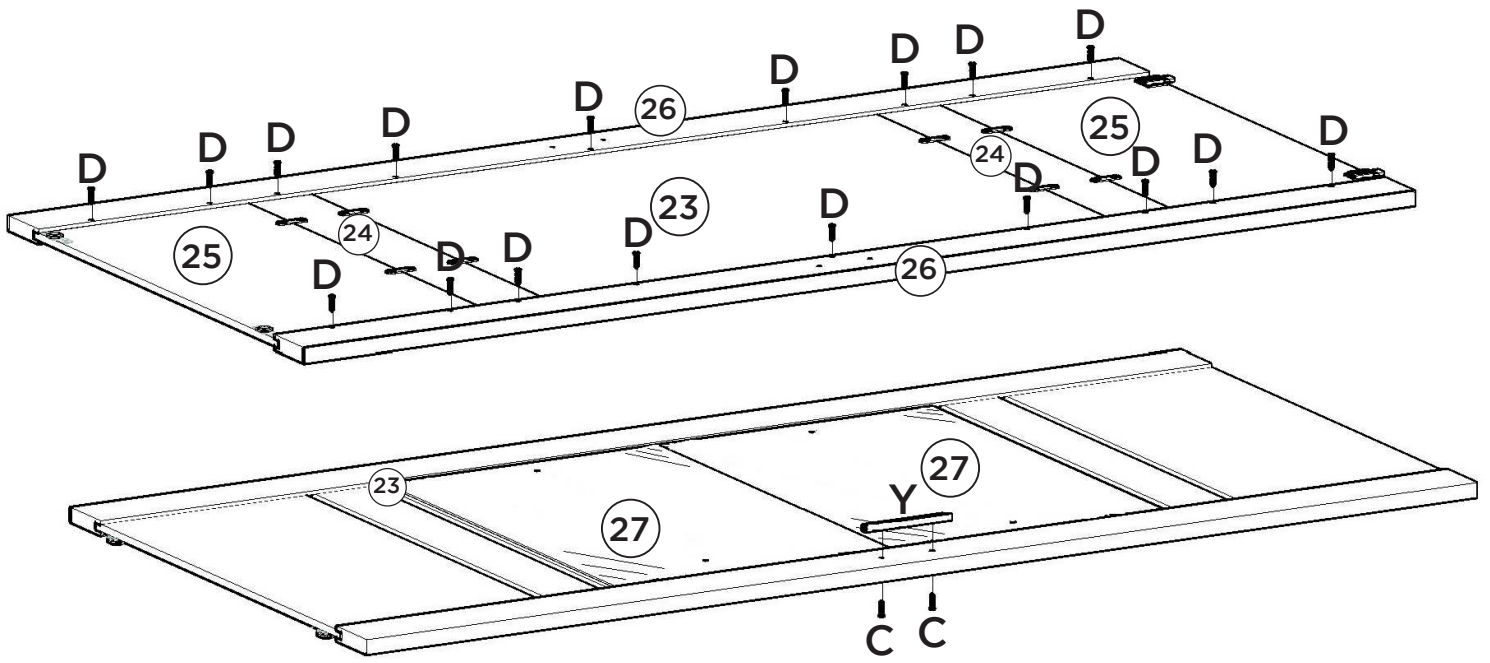

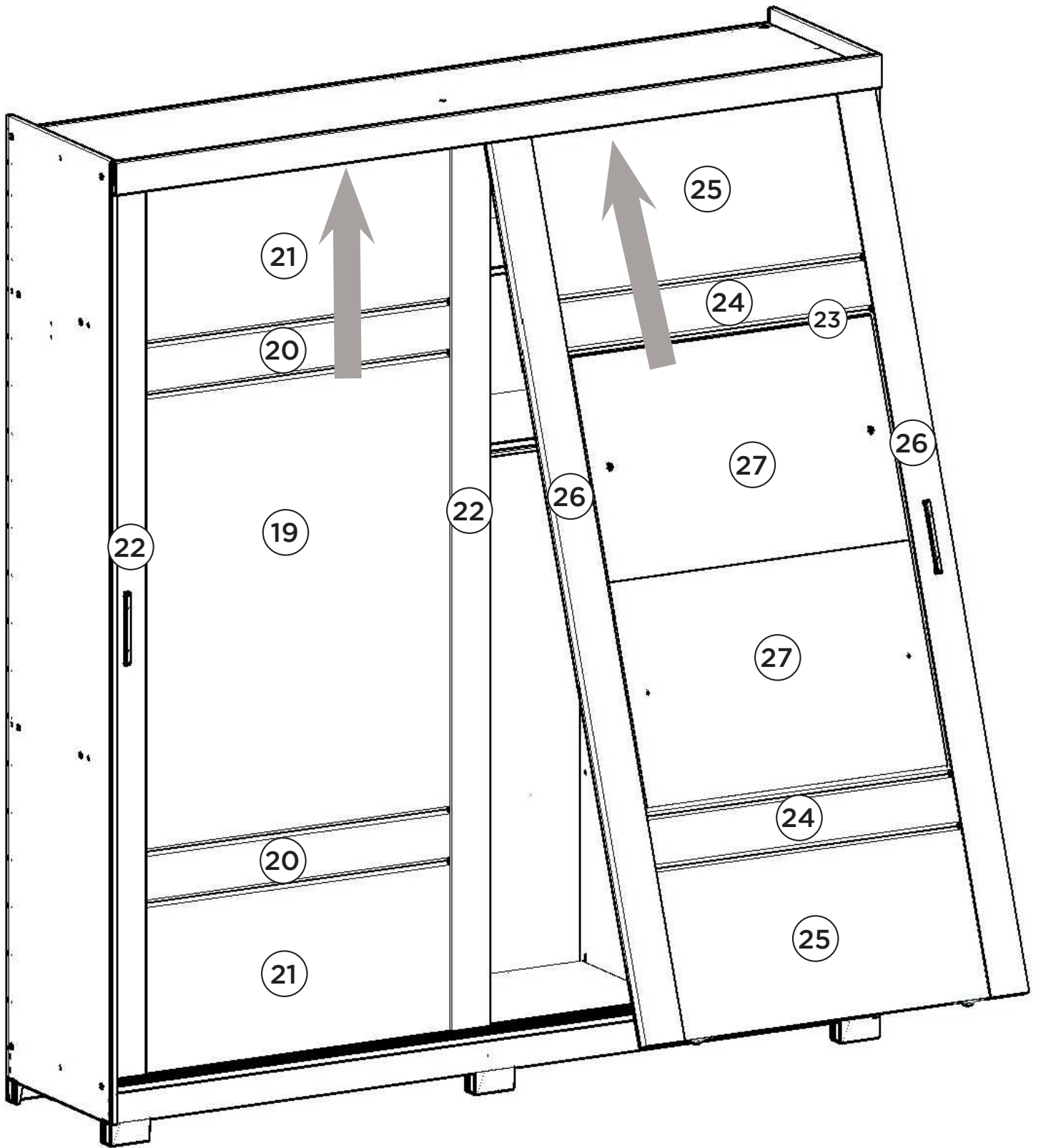

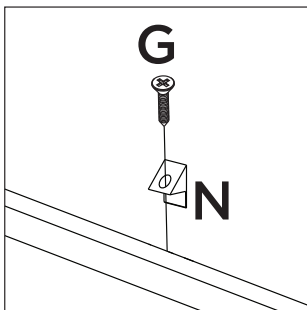
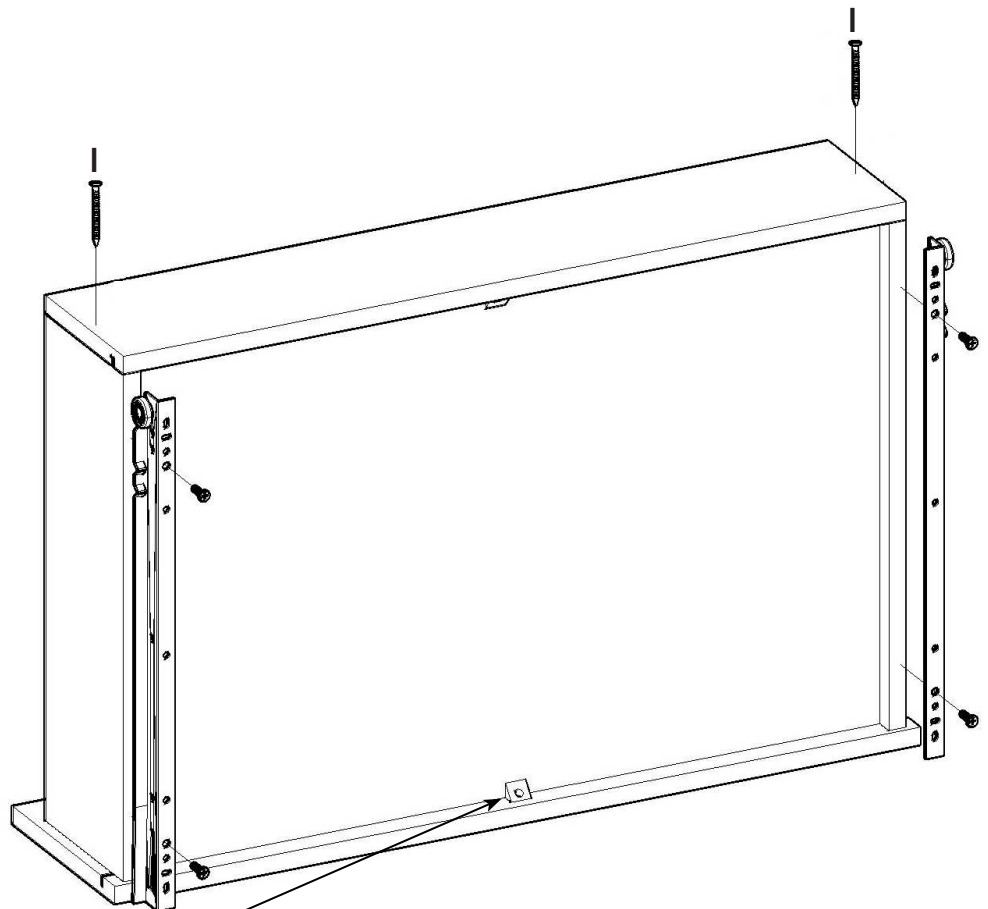
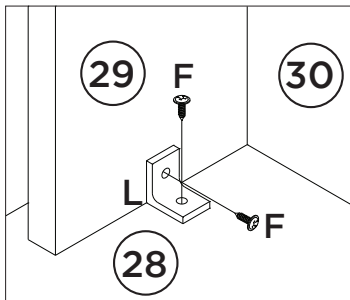
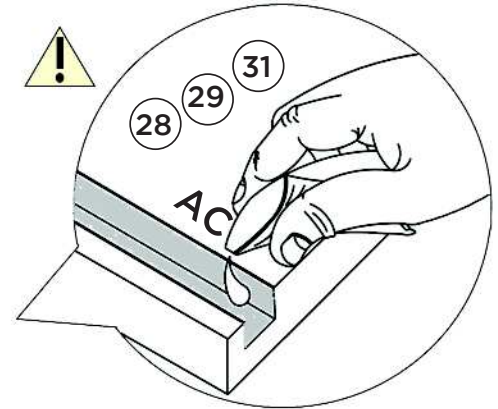
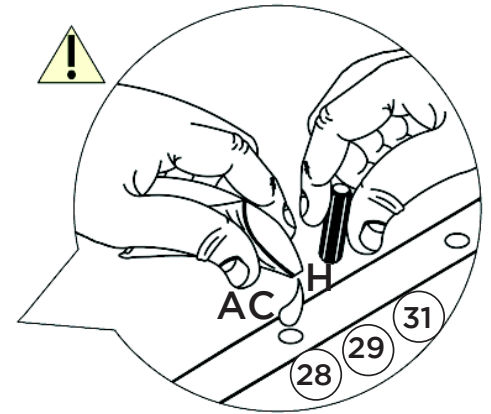
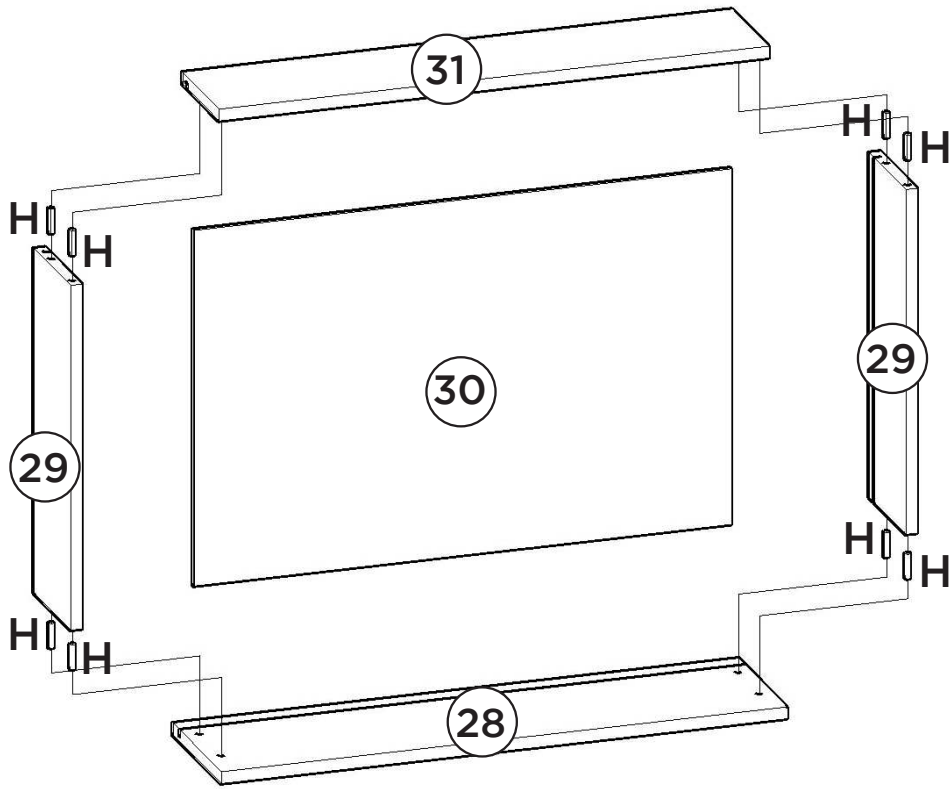









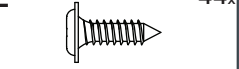
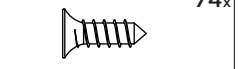



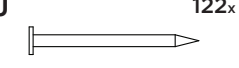





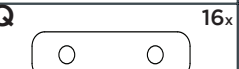

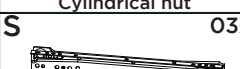

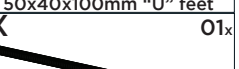

| Item  | Caixa<br>Caja<br>Box | Qty<br>Ctd<br>Qty | Descrição  <br>Descripción  <br>Description                                  | Medidas (mm)  <br>Dimensions (mm)  <br>Size (measurements)<br>(mm) |
|-------|----------------------|-------------------|--|--|
| 01    | 2/3                  | 01                | Rodapé frontal   Rodapié frontal   Front footboards                          | 1966x73x12   |
| 02    | 2/3                  | 01                | Travessa do rodapé   Carril pie   Footboard tray                             | 450x73x12  |
| 03    | 2/3                  | 01                | Rodapé traseiro   Rodapié trasero   Rear footboard                           | 1966x73x12   |
| 04    | 2/3                  | 01                | Base   Base   Base   | 1966x480x12  |
| 05    | 1/3                  | 01                | Divisão menor   División menor   Minor division                              | 742x400x12   |
| 06    | 2/3                  | 01                | Divisão   División   Division  | 1754x400x12  |
| 07    | 2/3                  | 01                | Divisão direita   División derecha   Right split                             | 1342x400x12  |
| 08    | 1/3                  | 01                | Lateral esquerda   Lateral izquierda   Left side                             | 2250x480x12  |
| 09    | 3/3                  | 01                | Tampo das Gavetas   Tapa del cajón   Drawer top                              | 977x400x12   |
| 10    | 2/3                  | 01                | Ripa do maleiro   Portaequipajes de ripa   Lath of the closet top shelf      | 350x73x12  |
| 11    | 2/3                  | 01                | Chão do maleiro   Piso del portaequipajes   Floor of the closet top shelf    | 1966x400x12  |
| 12    | 1/3 e 2/3            | 02                | Prateleira menor   estante más pequeño   smaller shelf                       | 478x350x12   |
| 13    | 3/3                  | 01                | Prateleira maior   estante más grande   larger shelf                         | 977x400x12   |
| 14    | 2/3                  | 01                | Tampo Superior   Tapa superior   Top   | 1966x480x12  |
| 15    | 1/3                  | 01                | Lateral direita   Lateral derecha   Right side                               | 2250x480x12  |
| 16    | 1/3                  | 01                | Chapéu   Sombrero   Hat  | 1988x73x12   |
| 17    | 1/3                  | 01                | Fundo Superior   Fondo Superior   Superior background                        | 1985x367x3   |
| 18    | 2/3                  | 04                | Fundo   Fondo   Bottom   | 1774x495x3   |
| 19    | 3/3                  | 01                | Painel Central   Panel central   Central Panel                               | 825x1068x12  |
| 20=24 | 3/3                  | 02                | Painel menor   Panel menor   Minor panel                                     | 825x120x12   |
| 21=25 | 3/3                  | 02                | Painel   Panel   Panel   | 825x396x12   |
| 22=26 | 1/3                  | 02                | Moldura frontal porta   marco de la puerta delantera   front door frame      | 2100x100x25  |
| 23    | 3/3                  | 01                | Painel Central Espelho   Panel central espejo   Mirror Central Panel         | 825x1068x12  |
| 24=20 | 3/3                  | 02                | Painel menor   Panel menor   Minor panel                                     | 825x120x12   |
| 25=21 | 3/3                  | 02                | Painel   Panel   Panel   | 825x396x12   |
| 26=22 | 1/3                  | 02                | Moldura frontal porta   marco de la puerta delantera   front door frame      | 2100x100x25  |
| 27    | 3/3                  | 02                | Espelho   Espejo   Mirror  | 778x515x3  |
| 28    | 1/3                  | 03                | Frente de gaveta   Frente del cajón   Drawer front                           | 572x145x12   |
| 29    | 1/3                  | 06                | Lado de gaveta   Lado del cajón   Drawer side                                | 350x110x12   |
| 30    | 1/3                  | 03                | Fundo de gaveta recortado   Fondo de cajón recortado   Drawer bottom trimmed | 542x361x3  |
| 31    | 1/3                  | 03                | Ripa de trás   Listón trasero   Rear batten                                  | 555x110x12   |

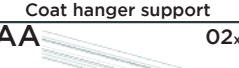
Ferragens | Herrajes | Hardware

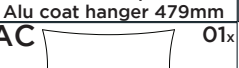
|   |   |   |   |  |  |
|---|---|---|---|--|--|
| <b>A</b><br><br>Parafuso 4,5x50mm CHT.<br>Tornillo 4,5x50mm CHT.<br>Screw 4,5x50mm CHT.   | <b>B</b><br><br>Parafuso 3,5x40mm CHT.<br>Tornillo 3,5x40mm CHT.<br>Screw 3,5x40mm CHT.                    | <b>C</b><br><br>Parafuso 3,5x30mm FLA.<br>Tornillo 3,5x30mm FLA.<br>Screw 3,5x30mm FLA.  | <b>D</b><br><br>Parafuso 3,5x22mm CHT.<br>Tornillo 3,5x22mm CHT.<br>Screw 3,5x22mm CHT.                   | <b>E</b><br><br>Parafuso 3,5x12mm FLA.<br>Tornillo 3,5x12mm FLA.<br>Screw 3,5x12mm FLA. | <b>F</b><br><br>Parafuso 3,5x12mm CHT.<br>Tornillo 3,5x12mm CHT.<br>Screw 3,5x12mm CHT. |
| <b>G</b><br><br>Parafuso 3,0x16mm CHT.<br>Tornillo 3,0x16mm CHT.<br>Screw 3,0x16mm CHT.   | <b>H</b><br><br>Cavilha 5x25mm<br>Cinta 5x25mm<br>Dowel 5x25mm   | <b>I</b><br><br>Prego 12x12mm Anelado<br>Clavo 12x12mm Anillado<br>Ringed Nails 12x12mm  | <b>J</b><br><br>Prego 10x10mm<br>Clavo 10x10mm<br>Nail 10x10mm  | <b>K</b><br><br>Fixador de fundos<br>Fijador de fondos<br>Bottom fixer                  | <b>L</b><br><br>Cantoneira plástica<br>Cantонера plástica<br>Plastic angle brackets     |
| <b>M</b><br><br>Porca cilíndrica<br>Tuerca cilíndrica<br>Cylindrical nut                  | <b>N</b><br><br>Cantoneira suporte triangular<br>Cantонера soporte triangular<br>Triangle support angle    | <b>O</b><br><br>Etiqueta resinada Henn<br>Etiqueta resinada Henn<br>Henn resin label     | <b>P</b><br><br>Adesivo tapa parafuso 10mm<br>Adhesivo tapón de tornillo 10mm<br>Bolt cover adhesive 10mm | <b>Q</b><br><br>Suporte de metal<br>Soporte de metal<br>Metal stands                    | <b>R</b><br><br>Pé "U" 50x40x100mm<br>Pie "U" 50x40x100mm<br>50x40x100mm "U" feet       |
| <b>S</b><br><br>Corrediça metal 350mm<br>Corredera de metal 350mm<br>Sliding metal 350mm  | <b>T</b><br><br>Kit Roldana JM135R (2Portas)<br>Kit Roldán JM135R (2Puertas)<br>JM135R Pulley Kit (2Doors) | <b>U</b><br><br>Suporte cabideiro<br>Soporte de percha<br>Coat hanger support            | <b>V</b><br><br>Cabideiro Alum. 969mm<br>Alu 969mm percha<br>Alu coat hanger 969mm                        | <b>W</b><br><br>Cabideiro Alum. 479mm<br>Alu 479mm percha<br>Alu coat hanger 479mm      | <b>X</b><br><br>Cabideiro Alum. 377mm<br>Alu 377mm percha<br>Alu coat hanger 377mm      |
| <b>Y</b><br><br>Puxador Alumínio 163mm<br>Tirador Alumínio 163mm<br>Handle Aluminum 163mm | <b>Z</b><br><br>Perfil "I" 1759mm<br>Perfil "I" 1759mm<br>Profile "I" 1759mm                               | <b>AA</b><br><br>Trilho Alumínio 1965mm<br>Riel Alumínio 1965mm<br>1965mm aluminum rails | <b>AB</b><br><br>Trilho PVC 1965mm<br>Carril PVC 1965mm<br>1965mm PVC rails                               | <b>AC</b><br><br>Sachê de cola<br>Bolsa de pegamento<br>Glue bag                        |  |