



| Nº | CÓDIGO CODE ASSISTÊNCIA ATTENDANCE | NOME DA PEÇA/DESCRIPCIÓN PIEZAS/DESCRIPTION PARTS | MEDIDAS (mm) MEASURES (mm) | QTD. | CINAMOMO OFF WHITE |
|----|---|---|-------------------------------|------|-----------------------|
| 01 | RD053.13.00 | Forro/Revés/botton | 1830x649x2.5 | 02 | 321061 |
| 02 | RD053.25.00 | Porta/Puerta/Door | 1803x649x15 | 02 | 342650 |
| 03 | RD053.04.00 | Base sob gaveta/Base cajón/Shelf | 637x370x12 | 01 | 321083 |
| 04 | RD053.02.00 | Base interna/Base/Shelf | 637x370x12 | 02 | 321082 |
| 05 | RD053.34.00 | Forro gaveta/Revés cajón/Botton | 562x355x2.5 | 02 | 321063 |
| 06 | RD053.17.00 | Lateral externa direita/Lateral derecha/Inner side | 2000x450x12 | 01 | 337639 |
| 07 | RD053.18.00 | Lateral externa esquerda/Lateral izquierda/Inner side | 2000x450x12 | 01 | 337640 |
| 08 | RD053.05.00 | Base superior/Base superior/Shelf | 1286x450x12 | 01 | 337637 |
| 09 | RD053.01.00 | Base inferior/Base inferior/Shelf | 1286x450x12 | 01 | 337636 |
| 10 | RD053.15.00 | Lateral gaveta/Lateral cajón/ Drawer side | 350x100x12 | 04 | 321087 |
| 11 | RD053.30.00 | Rodapé frontal/Zócalo delantero/Front panel Rodapé | 1286x100x12 | 01 | 337641 |
| 12 | RD053.32.00 | traseiro/Zócalo de atrás/Border back | 1286x100x12 | 01 | 321093 |
| 13 | RD053.07.00 | Chapéu/Detalle superior/Hat | 1310x100x12 | 01 | 337638 |
| 14 | RD053.14.00 | Frente gaveta/Frente cajón/Drawer front | 595x134x12 | 02 | 321086 |
| 15 | RD053.29.00 | Ripa Traseira de gaveta/Trasero cajón/Drawer back | 538x80x12 | 02 | 321091 |
| 16 | RD053.19.00 | Lateral interna central/Divisória interna/Inner side | 1818x370x12 | 01 | 321090 |
| 17 | 14209 | Espelho/Espejo/Mirror | 592x592x3 | 02 | |

Ferragens/Herrajes/Hardware

A  **12x**
Cód 873
Cavilha/ Clavija/Peg Ø6,0x30mm

B  **32x**
Cód 691
Parafuso/Tornillo/Screw 3,5x40mm Chat

C  **41x**
Cód 11413
Parafuso/Tornillo/Screw 3x12mm Chat

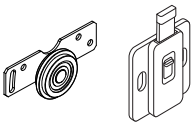
D  **02x**
Cód 2495
Sistema de correr/sistema deslizante/sliding system

E  **16x**
Cód 667
Parafuso/Tornillo/Screw 4x14mm Chat

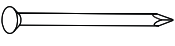
F  **04x**
Cód 821
Prego 12x12/Clavo/Nail

G  **08x**
Cód 9567
Parafuso/Screw 3x22mm Cht.

H  **10x**
Cód 7169
Fixador costa/Ujetador de orilla/Shore fastener

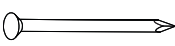
I  **56x**
Cód 822
Prego 8x8/Clavo/Nail

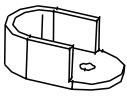
J  **04x**
Cód 857
Suporte cabideiro/Soporte de suspensión/hanger support

K  **07x**
Cód 7168
Cantoneira metálica/angulo metálico Metal angle bracket

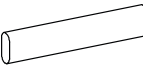
L  **02x**
Cód 13312
Cabideiro/Tendedeiro/Wooden hanger 655mm

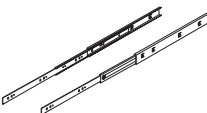
M  **02x**
Cód 20253
Corrediças/Diapostivas/Slides

N  **02x**
Cód 12012
Puxador/Manija/Puller

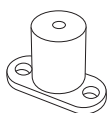
O  **08x**
Cód 728
Distanciador/Espaciador/Spacer 25mm

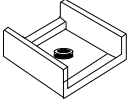

P  **04x**
Cód 800
Sapata 12x12/zapata/shoe

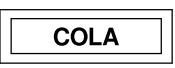
Q  **01x**
Cód 13371
Trilho inferior/Riel superior/Bottom rail

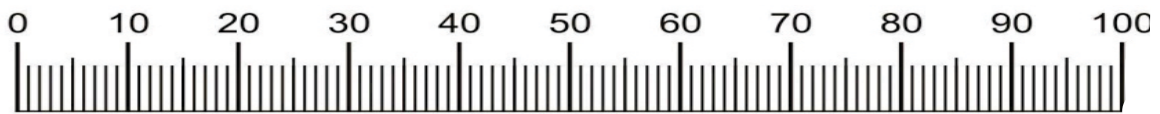
R  **01x**
Cód 8255
Bisnaga cola/tubo de pegamento/glue tube



Medidas em mm
Measures in mm
Mesuras en mm

| | |
|---|---|
|  | Produto para ser aplicado em caso de riscos na superfície. |
|  | Product to be applied in case of scratches on the surface. |
|  | Producto para ser aplicado en caso de rayas en la superficie. |

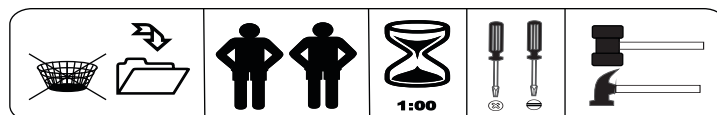

Pré-Montagem/Preparación Piezas/ Pre-assembly

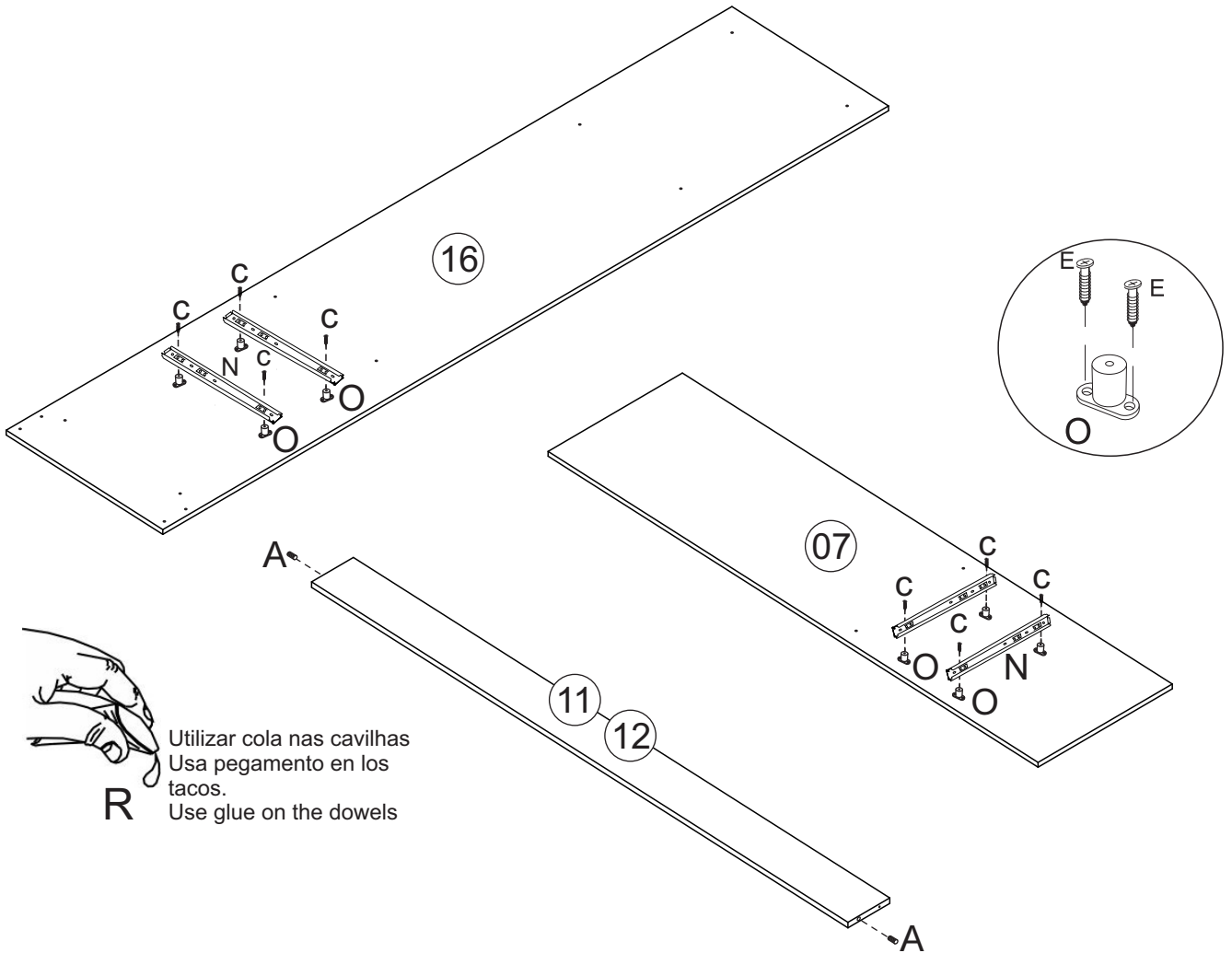

R

Utilizar cola nas cavilhas
 Usa pegamento en los
 tacos.
 Use glue on the dowels

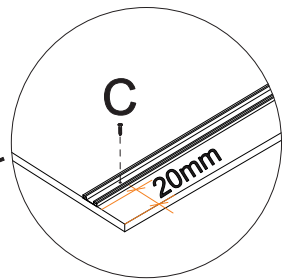
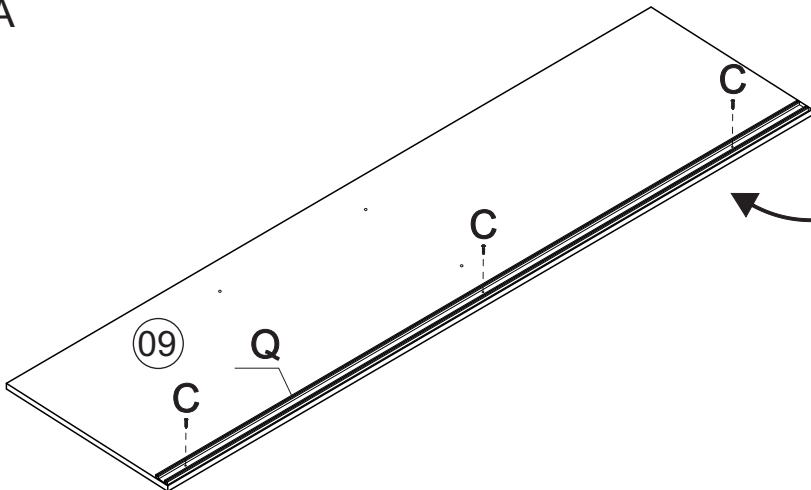
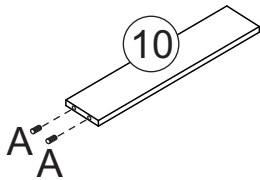

Obs: O trilho inferior deve ser montado a 20mm da borda da base até a ponta do trilho.

Nota: El riel inferior debe montarse a 20 mm del borde de la base hasta el final del riel.

Note: The bottom rail should be mounted 20mm from the edge of the base to the end of the rail.

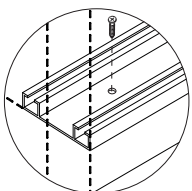

01 Montagem/Montaje/Assembly

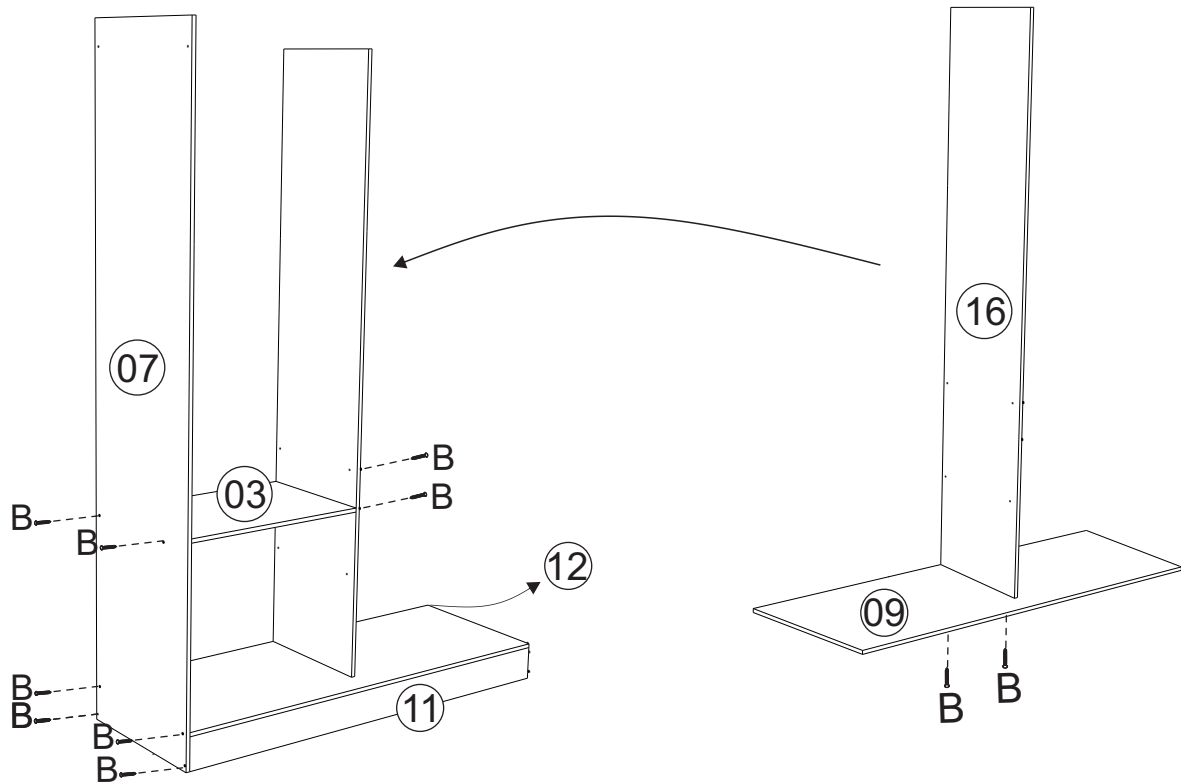

02 Montagem/Montaje/Assembly

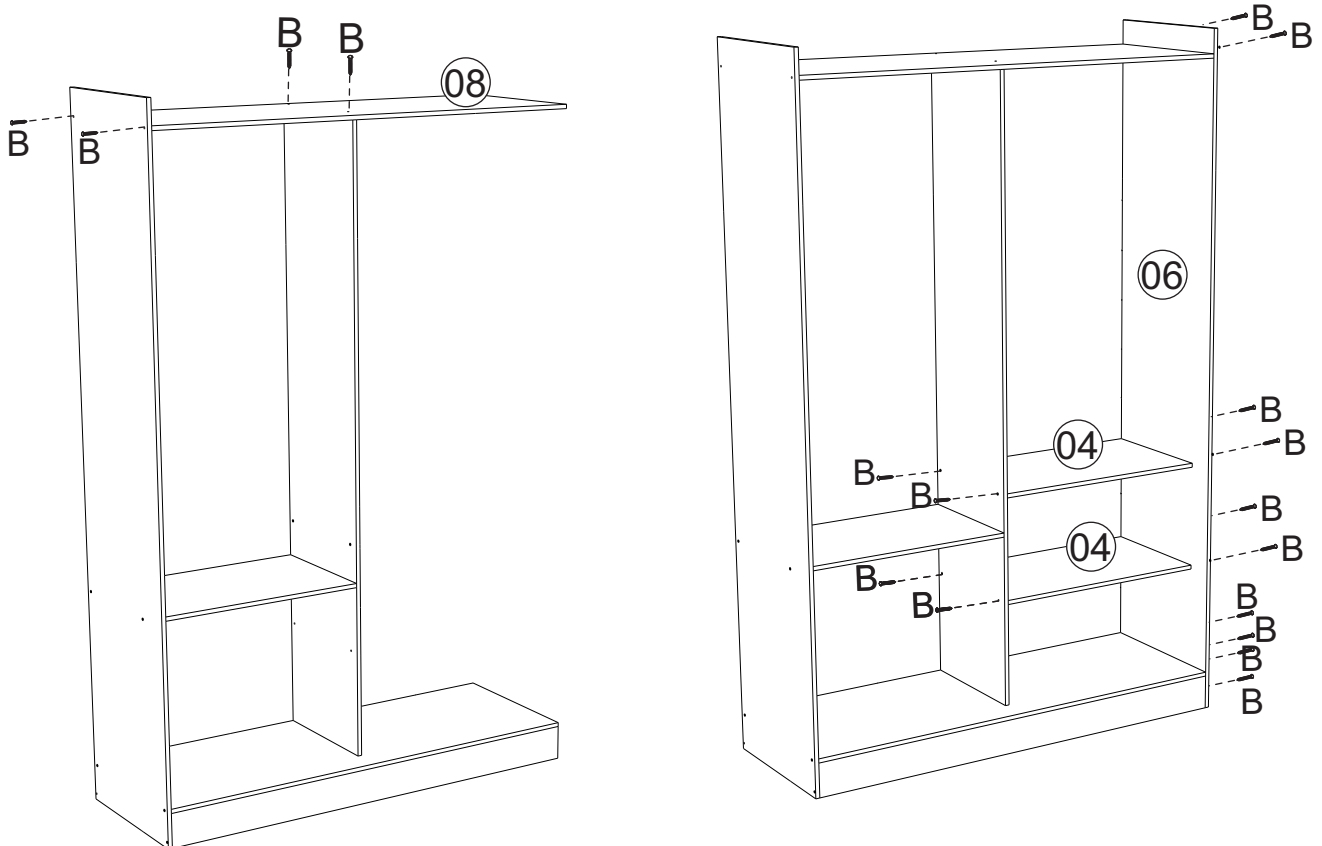

03 Montagem/Montaje/Assembly

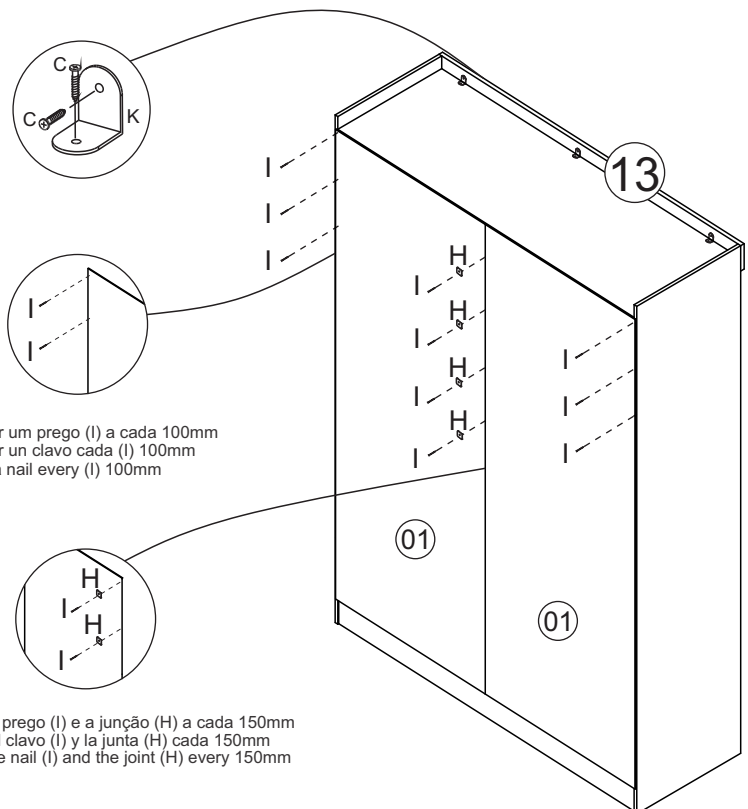

04 Montagem/Montaje/Assembly

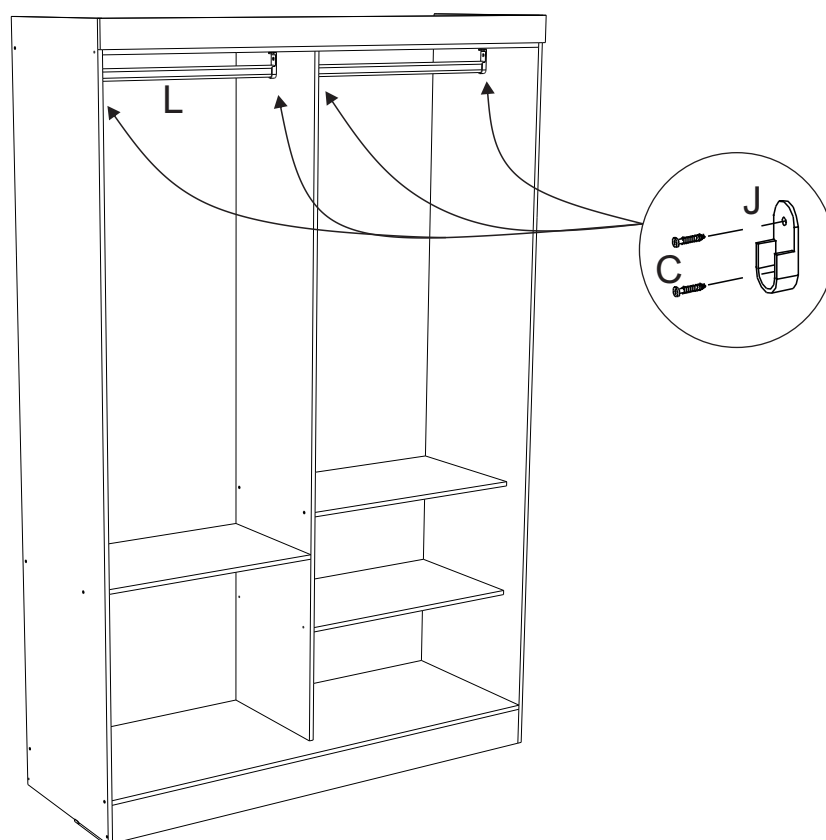

05 Montagem/Montaje/Assembly

(2x)

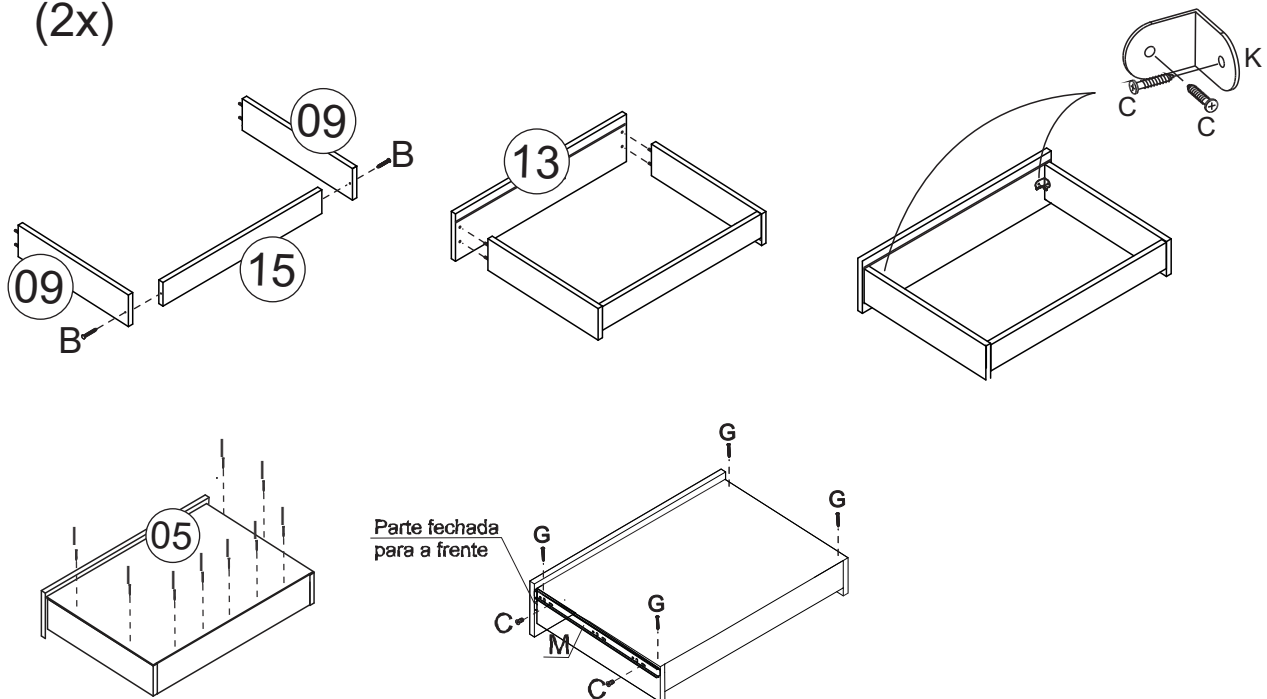

06 Montagem/Montaje/Assembly

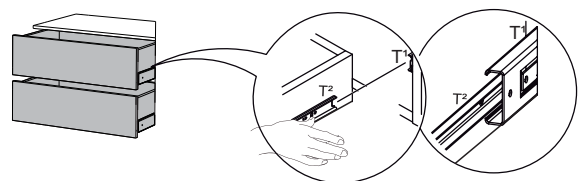
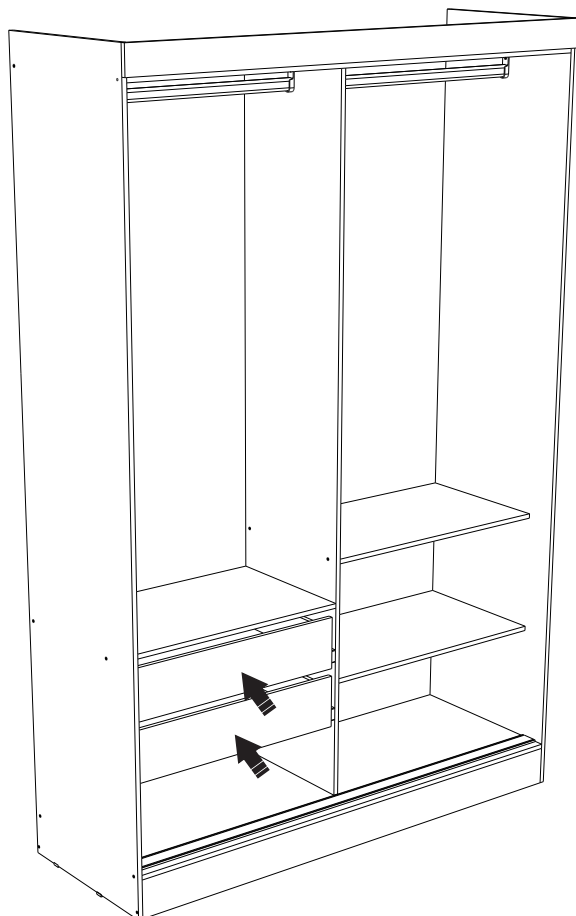

Limpeza/Limpieza

- ≠ Use um pano levemente umedecido com água, seguido de pano seco.
- ≠ Use solamente un paño húmedo con agua y después un paño seco.
- ≠ Use a cloth slightly dampened with water, followed by a dry cloth.
- ≠ Nunca utilize produtos químicos ou abrasivos.
- ≠ No utilice productos químicos o abrasivos.
- ≠ Never use chemical or abrasive products.

Montagem/Montaje/Assembly

07

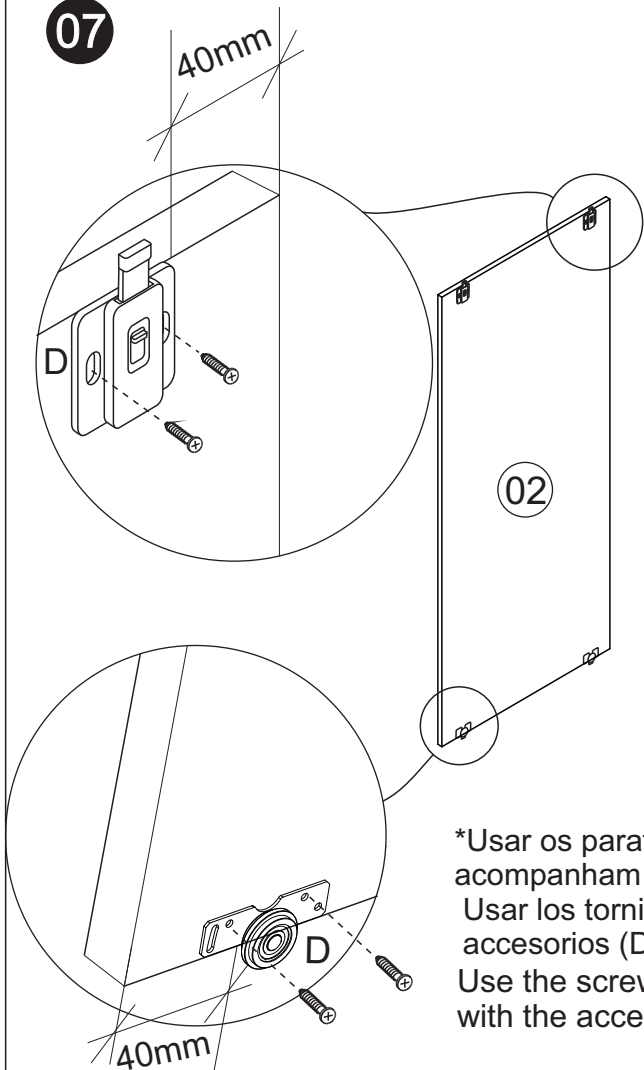

(2x)

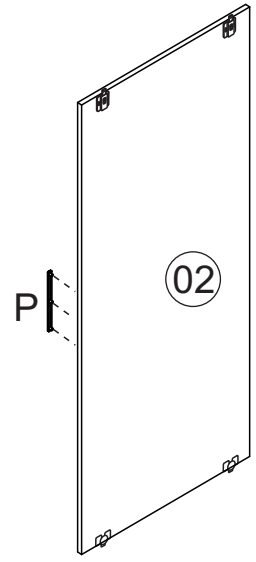

*Usar os parafusos que acompanham os acessórios (D).
 Usar los tornillos que acompaña los accesorios (D).
 Use the screws that come with the accessories (D)

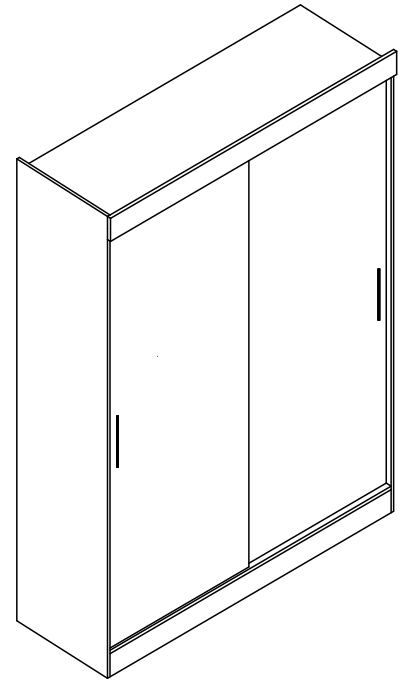
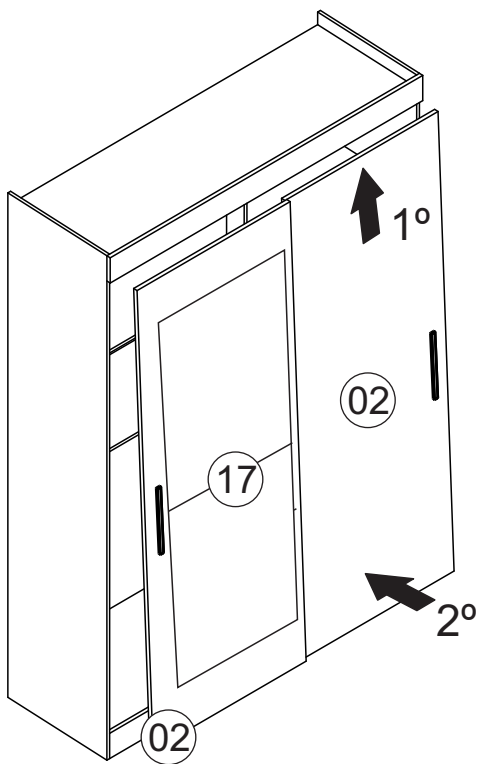

*Encaixar as portas primeiro no trilho superior e depois no trilho inferior.
 Encajar primero las puertas en el trillo superior y después en el trillo inferior.
 Fit the doors to the top rail first and

