



Nº	CÓDIGO CODE ASSISTÊNCIA ATTENDANCE	NOME DA PEÇA/DESCRIPCIÓN PIEZAS/DESCRIPTION PARTS	MEDIDAS (mm) MEASURES (mm)	QTD.	CINAMOMO OFF WHITE
01	RD053.13.00	Forro/Revés/botton	1830x649x2.5	02	321061
02	RD053.25.00	Porta/Puerta/Door	1803x649x15	02	342650
03	RD053.04.00	Base sob gaveta/Base cajón/Shelf	637x370x12	01	321083
04	RD053.02.00	Base interna/Base/Shelf	637x370x12	02	321082
05	RD053.34.00	Forro gaveta/Revés cajón/Botton	562x355x2.5	02	321063
06	RD053.17.00	Lateral externa direita/Lateral derecha/Inner side	2000x450x12	01	337639
07	RD053.18.00	Lateral externa esquerda/Lateral izquierda/Inner side	2000x450x12	01	337640
08	RD053.05.00	Base superior/Base superior/Shelf	1286x450x12	01	337637
09	RD053.01.00	Base inferior/Base inferior/Shelf	1286x450x12	01	337636
10	RD053.15.00	Lateral gaveta/Lateral cajón/ Drawer side	350x100x12	04	321087
11	RD053.30.00	Rodapé frontal/Zócalo delantero/Front panel Rodapé	1286x100x12	01	337641
12	RD053.32.00	traseiro/Zócalo de atrás/Border back	1286x100x12	01	321093
13	RD053.07.00	Chapéu/Detalle superior/Hat	1310x100x12	01	337638
14	RD053.14.00	Frente gaveta/Frente cajón/Drawer front	595x134x12	02	321086
15	RD053.29.00	Ripa Traseira de gaveta/Trasero cajón/Drawer back	538x80x12	02	321091
16	RD053.19.00	Lateral interna central/Divisória interna/Inner side	1818x370x12	01	321090
17	14209	Espelho/Espejo/Mirror	592x592x3	02	

Ferragens/Herrajes/Hardware

A  **12x**
Cód 873
Cavilha/ Clavija/Peg Ø6,0x30mm

B  **32x**
Cód 691
Parafuso/Tornillo/Screw 3,5x40mm Chat

C  **41x**
Cód 11413
Parafuso/Tornillo/Screw 3x12mm Chat

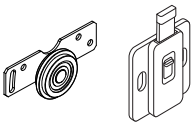
D  **02x**
Cód 2495
Sistema de correr/sistema deslizante/sliding system

E  **16x**
Cód 667
Parafuso/Tornillo/Screw 4x14mm Chat

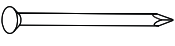
F  **04x**
Cód 821
Prego 12x12/Clavo/Nail

G  **08x**
Cód 9567
Parafuso/Screw 3x22mm Cht.

H  **10x**
Cód 7169
Fixador costa/Ujetador de orilla/Shore fastener

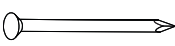
I  **56x**
Cód 822
Prego 8x8/Clavo/Nail

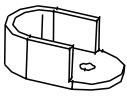
J  **04x**
Cód 857
Suporte cabideiro/Soporte de suspensión/hanger support

K  **07x**
Cód 7168
Cantoneira metálica/angulo metálico Metal angle bracket

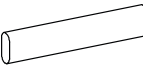
L  **02x**
Cód 13312
Cabideiro/Tendedeiro/Wooden hanger 655mm

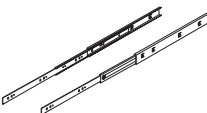
M  **02x**
Cód 20253
Corrediças/Diapostivas/Slides

N  **02x**
Cód 12012
Puxador/Manija/Puller

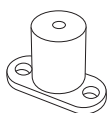
O  **08x**
Cód 728
Distanciador/Espaciador/Spacer 25mm

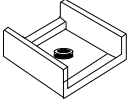

P  **04x**
Cód 800
Sapata 12x12/zapata/shoe

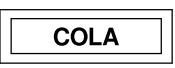
Q  **01x**
Cód 13371
Trilho inferior/Riel superior/Bottom rail

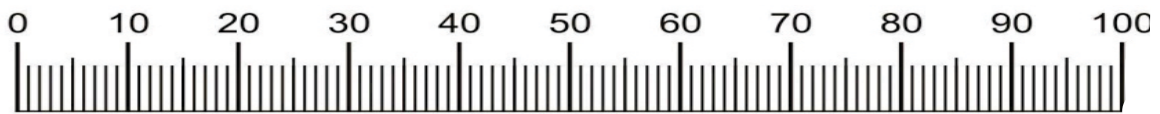
R  **01x**
Cód 8255
Bisnaga cola/tubo de pegamento/glue tube



Medidas em mm
Measures in mm
Mesuras en mm

	Produto para ser aplicado em caso de riscos na superfície.
	Product to be applied in case of scratches on the surface.
	Producto para ser aplicado en caso de rayas en la superficie.

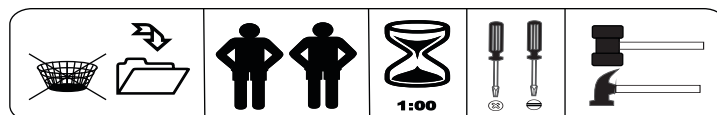

Pré-Montagem/Preparación Piezas/ Pre-assembly

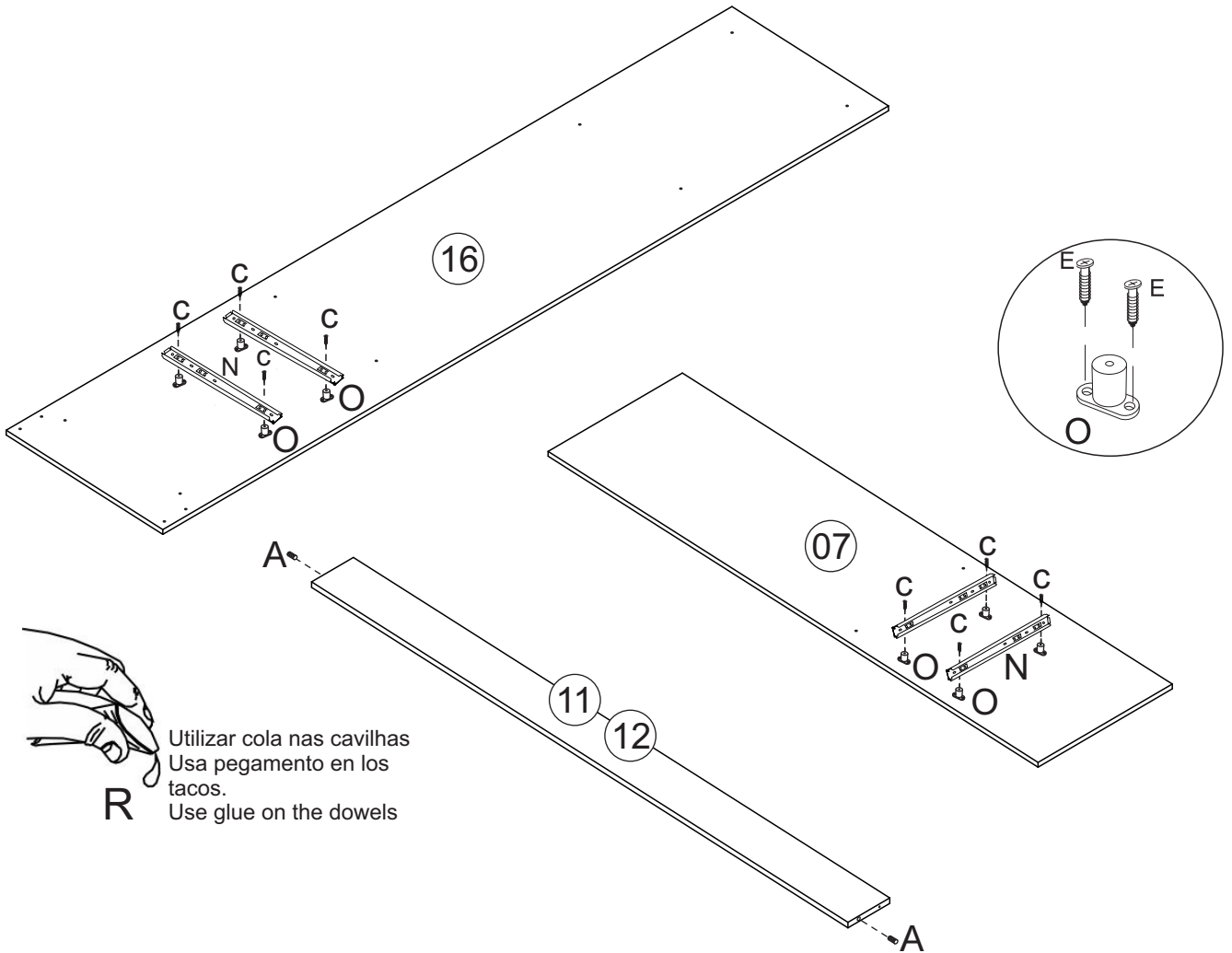

R

Utilizar cola nas cavilhas
Usa pegamento en los
tacos.
Use glue on the dowels

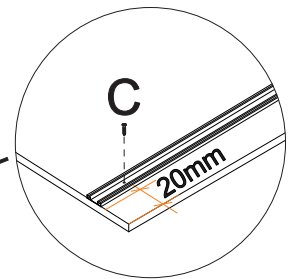
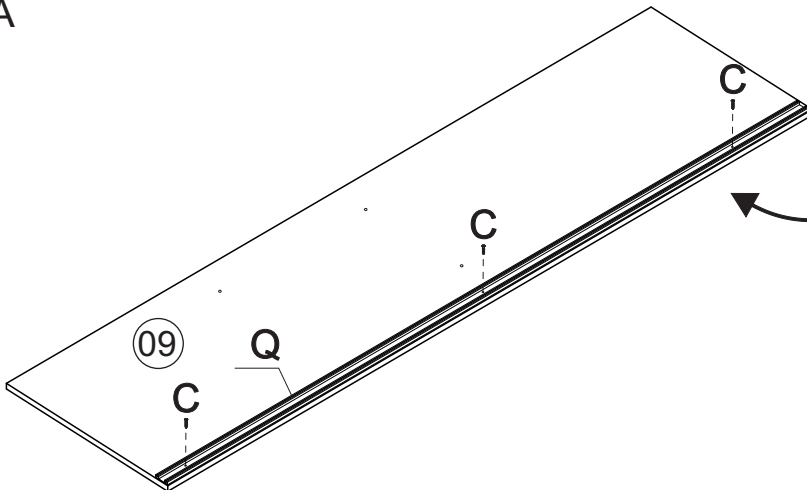
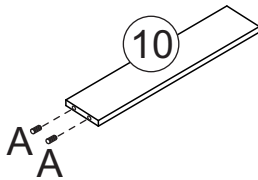

Obs: O trilho inferior deve ser montado a 20mm da borda da base até a ponta do trilho.

Nota: El riel inferior debe montarse a 20 mm del borde de la base hasta el final del riel.

Note: The bottom rail should be mounted 20mm from the edge of the base to the end of the rail.

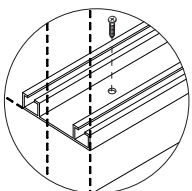

01 Montagem/Montaje/Assembly

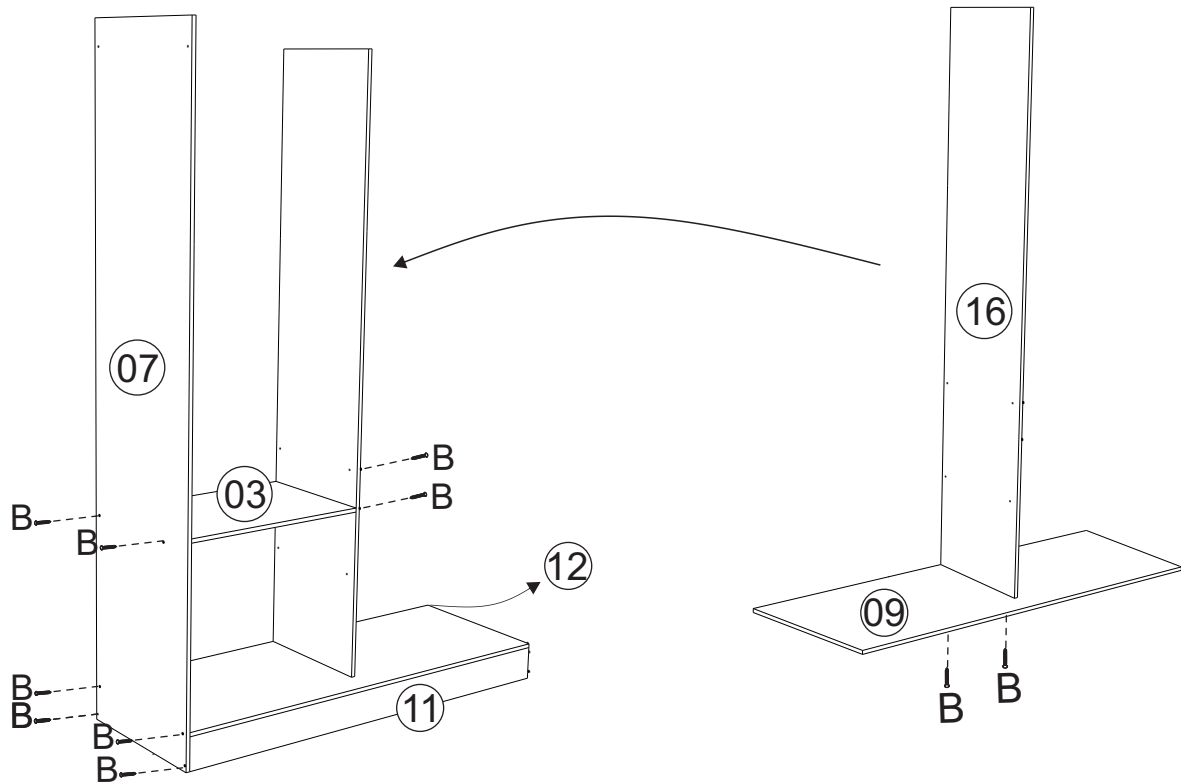

02 Montagem/Montaje/Assembly

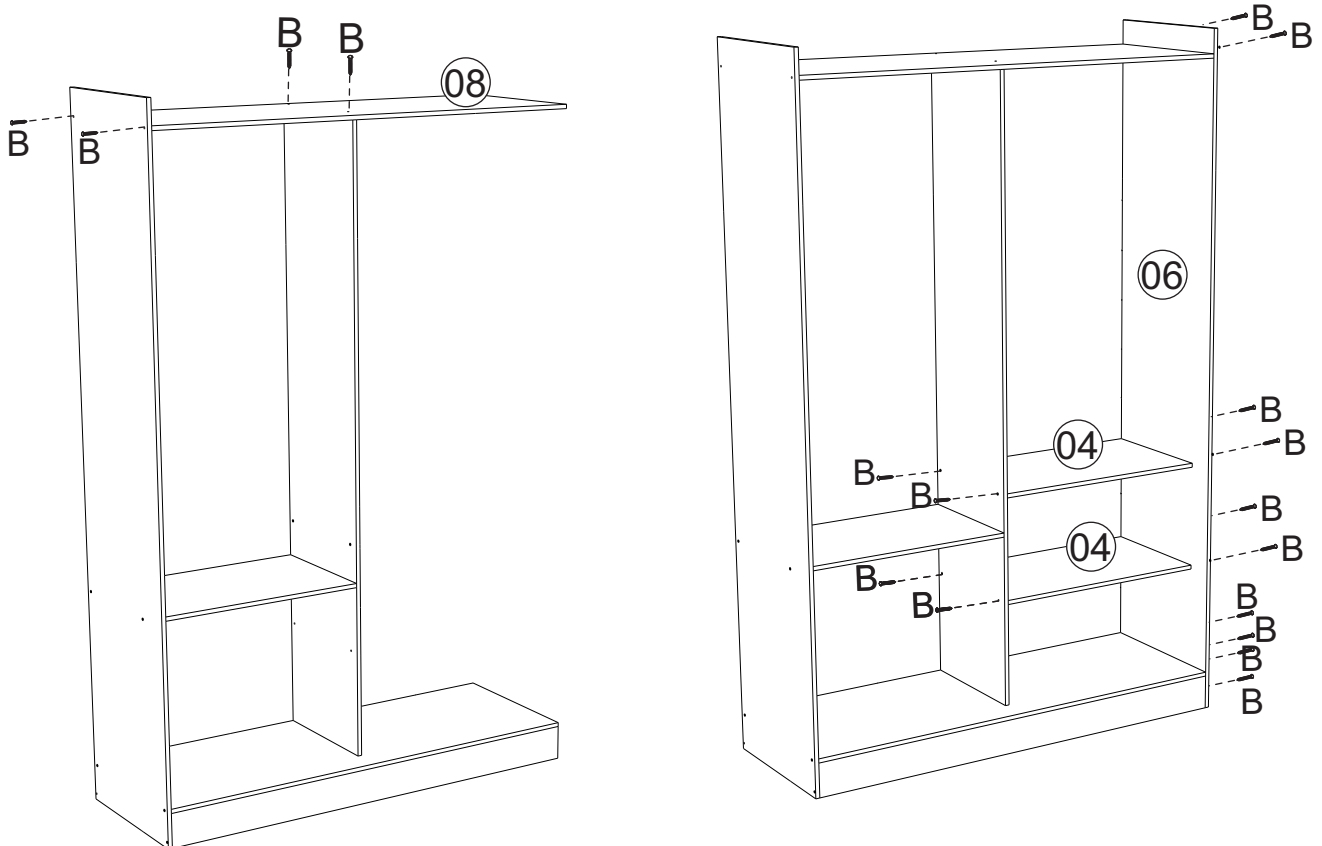

03 Montagem/Montaje/Assembly

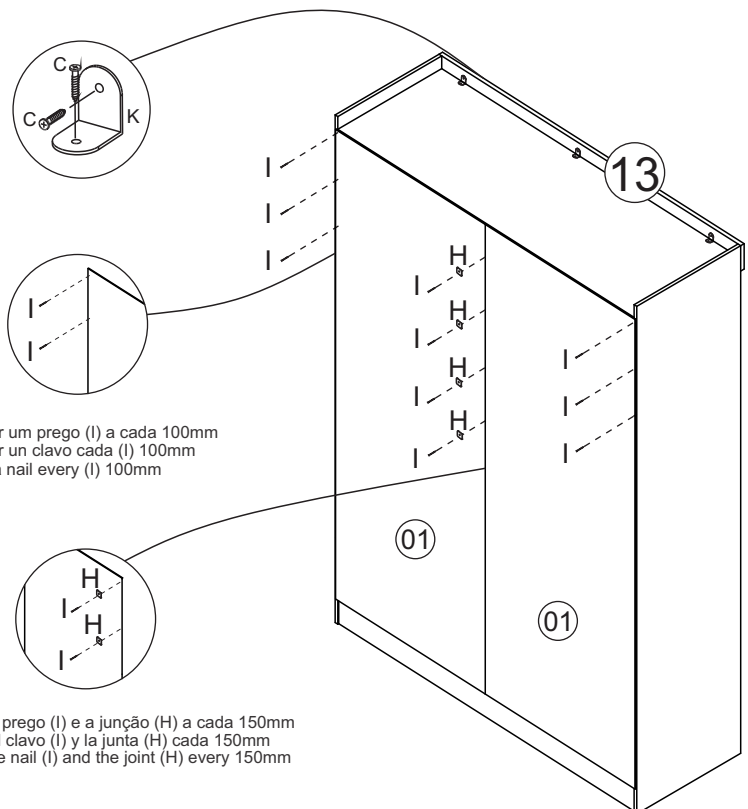

04 Montagem/Montaje/Assembly

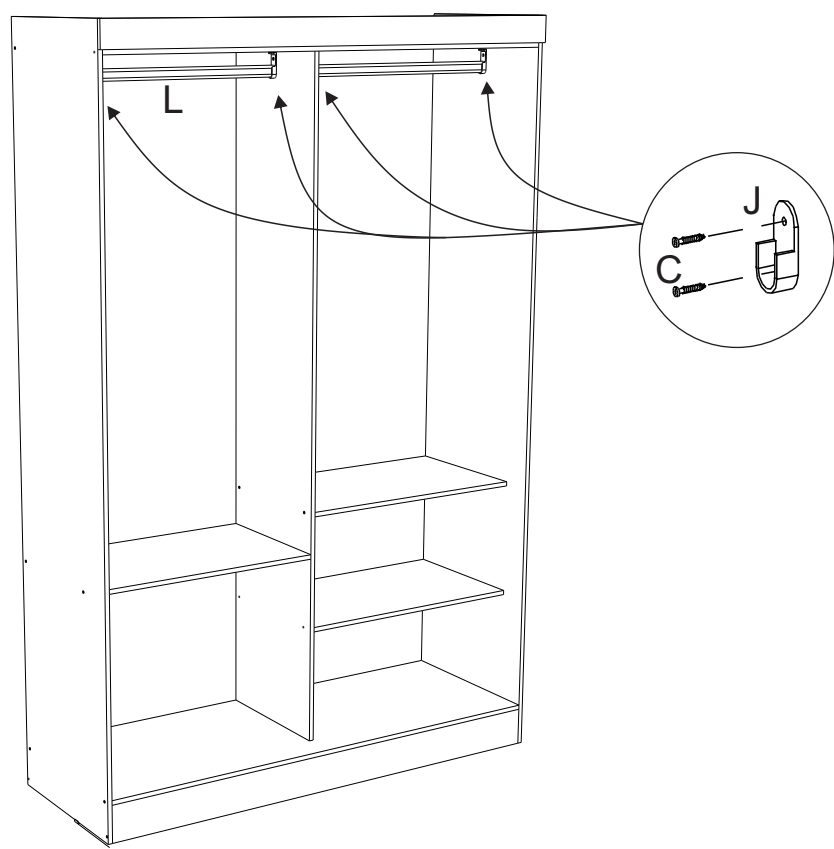

05 Montagem/Montaje/Assembly

(2x)

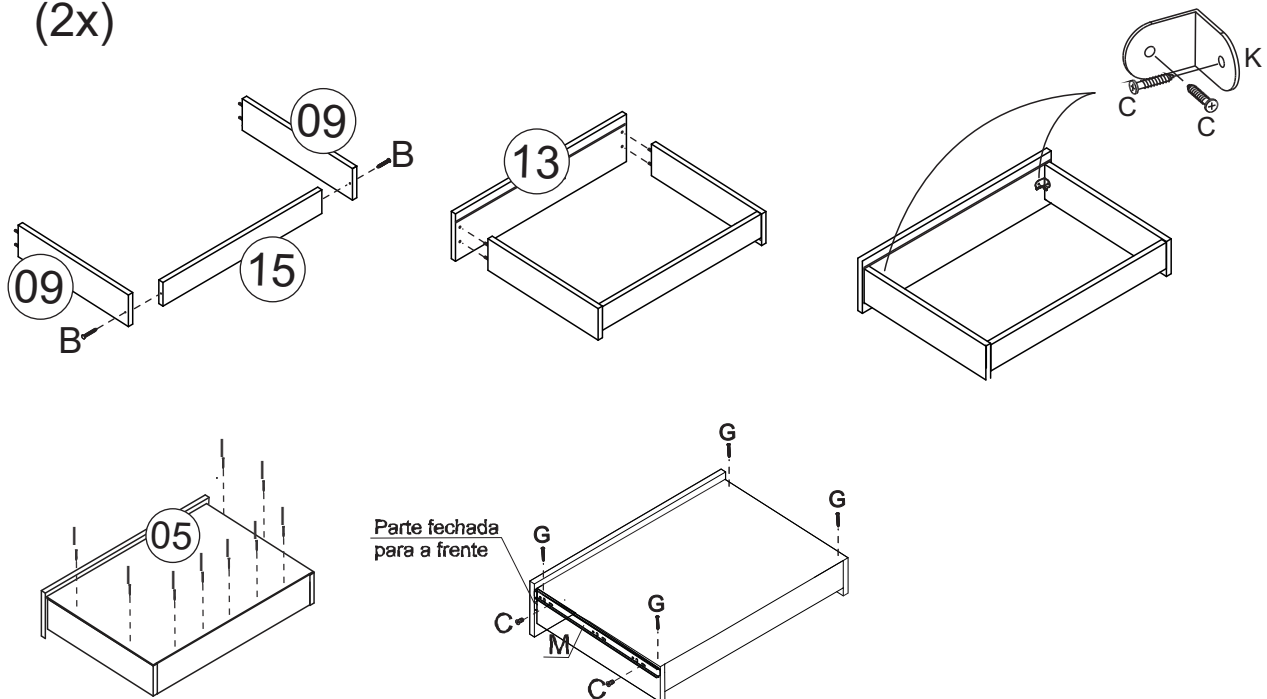

06 Montagem/Montaje/Assembly

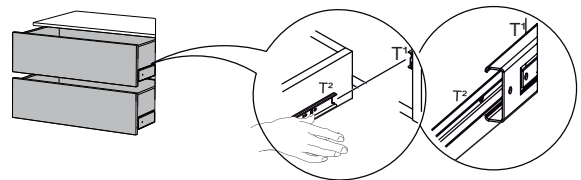
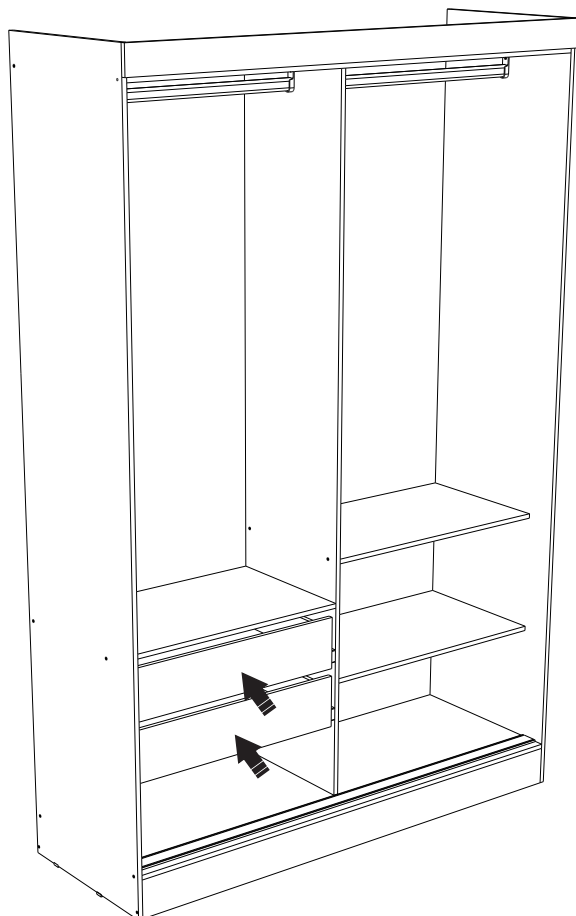

Limpeza/Limpieza

- ≠ Use um pano levemente umedecido com água, seguido de pano seco.
- ≠ Use solamente un paño húmedo con agua y después un paño seco.
- ≠ Use a cloth slightly dampened with water, followed by a dry cloth.
- ≠ Nunca utilize produtos químicos ou abrasivos.
- ≠ No utilice productos químicos o abrasivos.
- ≠ Never use chemical or abrasive products.

Montagem/Montaje/Assembly

07

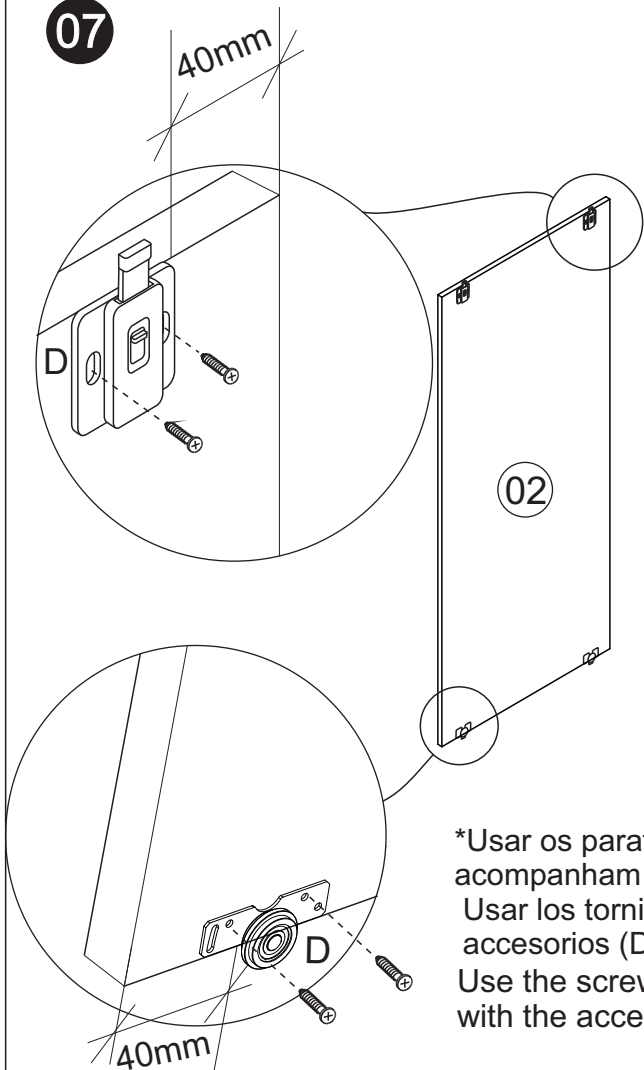

(2x)

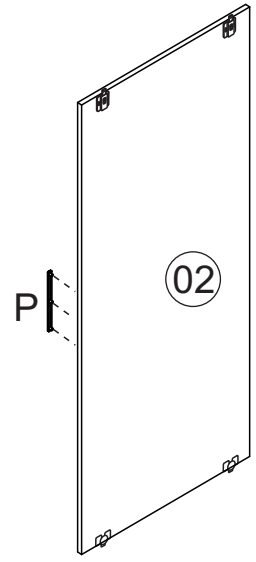

*Usar os parafusos que acompanham os acessórios (D).
 Usar los tornillos que acompaña los accesorios (D).
 Use the screws that come with the accessories (D)

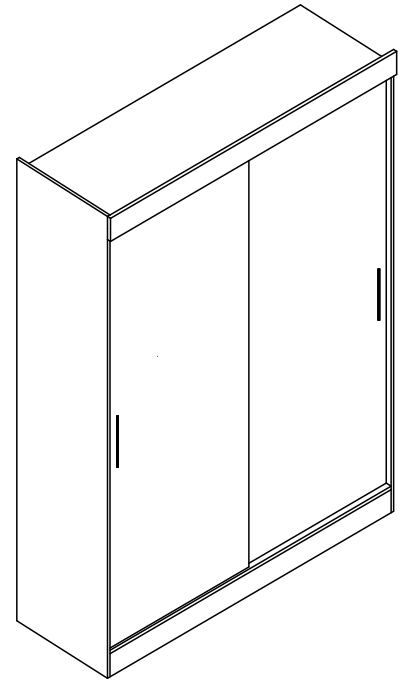
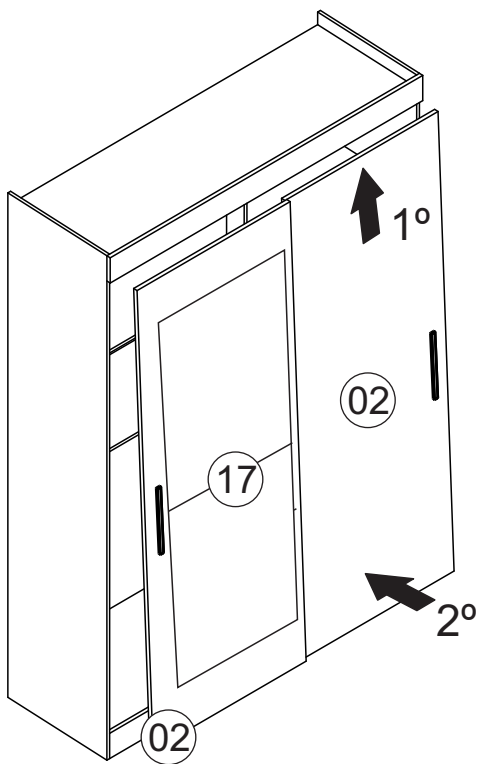

*Encaixar as portas primeiro no trilho superior e depois no trilho inferior.
 Encajar primero las puertas en el trillo superior y después en el trillo inferior.
 Fit the doors to the top rail first and

Ref.RD053

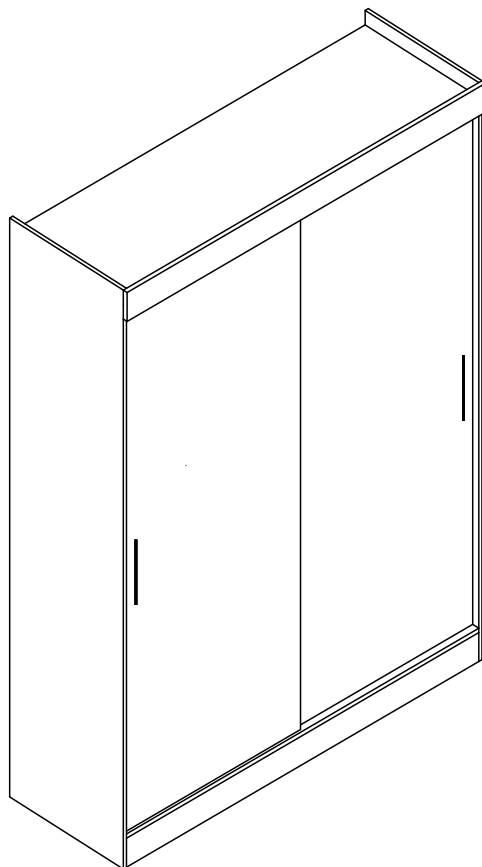

Ref.RD053.E

