

HENNInd. e Com. de Móveis Henn
Mondaí - SC - Brasil

☎ +55 49 3674.3500

📱 @moveishenn
www.henn.com.br**INSTRUÇÕES DE
MONTAGEM**INSTRUCCIONES DE MONTAJE
ASSEMBLY INSTRUCTIONS**ROUPEIRO PREMIUM 06 PORTAS |**

ARMARIO PREMIUM 06 PUERTAS CORREDERAS | WARDROBE PREMIUM 06 DOORS

D338-129 Off White/Nature

D338-212 Preto HP/Nature

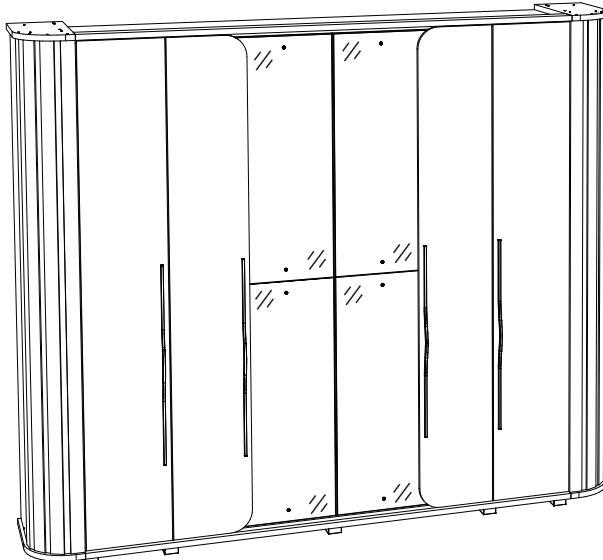
**AVISO**

Para limpeza de seu móvel, use uma flanela seca ou umedecida, e não utilize produtos químicos que possam danificar seu produto.

SISTEMA DE MONTAGEM

O sistema de montagem dos produtos, funciona de acordo com a ordem crescente dos números indicados no desenho. Ex: 01, 02, 03, 04... até a conclusão da montagem.

ASSISTÊNCIA TÉCNICA

Para solicitação de Assistência Técnica você consumidor deverá entrar em contato com o Lojista o qual você realizou a compra deste produto e solicitar a assistência técnica das peças avariadas. A garantia abrange todas as peças, partes e componentes que eventualmente venham apresentar defeito de fabricação no prazo de 03 (três) meses, contando a partir da entrega do produto ao consumidor, mediante nota fiscal de compra. Se houver qualquer alteração na estrutura do produto ou ocorrer defeito por negligência do montador/consumidor em relação a instrução de montagem e manuseio, não será fornecido assistência técnica gratuita.

ADVERTENCIA

Para limpieza de su móvil, use una flanela seca o húmeda, y no utilice productos químicos que puedan dañar su producto.

SISTEMA DE MONTAJE

El sistema de montaje de los productos funciona de acuerdo con el orden creciente de los números indicados en el dibujo. Ej.: 01, 02, 03, 04... hasta la conclusión del montaje.

ASISTENCIA TÉCNICA

Para solicitar Asistencia Técnica, el consumidor debe comunicarse con el Comercio que usted realizó la compra de este producto y solicita asistencia técnica para las partes dañadas. La garantía cubre todas las partes, piezas y componentes que eventualmente puedan presentar defecto de fabricación en el plazo de 03 (tres) meses, contados a partir de la entrega del producto al consumidor, mediante factura de compra. Si se produce algún cambio en la estructura del producto o se produce un defecto por negligencia del montador/consumidor en relación con las instrucciones de montaje y manipulación, no se prestará asistencia técnica gratuita.

NOTICE

To clean your furniture, use a dry or wet cloth, and do not use chemicals that may damage your product.

ASSEMBLY SYSTEM











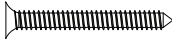





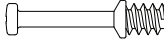

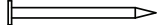



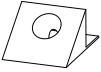

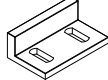
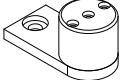

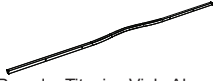
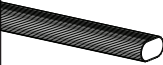

The products' assembly system works according to the increasing order of the indicated numbers. For example: 01, 02, 03, 04 ... to the end of the assembly.

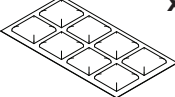
TECHNICAL ASSISTANCE

To request Technical Assistance, the consumer must contact the retailer from whom you purchased this product and request technical assistance for the damaged parts. The warranty covers all parts, parts and components that may eventually present a manufacturing defect within a period of 03 (three) months, counting from the delivery of the product to the consumer, by means of a purchase invoice. If there is any change in the structure of the product or defect occurs due to negligence of the assembler/consumer in relation to the assembly and handling instruction, free technical assistance will not be provided.

ACESSÓRIOS | ACCESORIOS | ACCESSORIES

ITM/D338-

<p>A x33</p>  <p>Parafuso 4,0x45mm CHT.</p>	<p>B x81</p>  <p>Parafuso 4,0x35mm CHT.</p>	<p>C x10</p>  <p>Parafuso 4,0x25mm CHT.</p>	<p>D x16</p>  <p>Parafuso 3,5x22mm CHT.</p>
<p>E x282</p>  <p>Parafuso 4,0x14mm CHT.</p>	<p>F x8</p>  <p>Parafuso 3,5x14mm FLA.</p>	<p>G x8</p>  <p>Bucha Fixador Espelho</p>	<p>H x9</p>  <p>Parafuso Minifix</p>
<p>I x9</p>  <p>Tambor Minifix</p>	<p>J x239</p>  <p>Prego 10x10mm</p>	<p>K x59</p>  <p>Fixador de Fundo</p>	<p>L x136</p>  <p>Cavilha 8x25mm</p>
<p>M x21</p>  <p>Cantoneira de Fixação Zamac</p>	<p>N x12</p>  <p>Cantoneira Suporte Triangular</p>	<p>O x4</p>  <p>Suporte Cabideiro Oblongo</p>	<p>P x2</p>  <p>Batente 15x25mm</p>
<p>Q x12</p>  <p>Distanciador de Correção</p>	<p>R x24</p>  <p>Dob 35mm POP Alta C/Amortecedor + Calço Fixo</p>	<p>S KIT x1</p> <p>Sapata Retangular 70x60mm (com 10 unidades)</p>	<p>T x2</p>  <p>Sapata 150x50x32mm</p>
<p>U PARES x6</p>  <p>Correção Telescópica 300x30mm</p>	<p>V x4</p>  <p>Puxador Titanius Viola Alum. 873mm</p>	<p>W x2</p>  <p>Cabideiro Oblongo 706mm</p>	<p>X x4</p>  <p>Perfil "H" 2172mm</p>
<p>Y x1</p>  <p>Perfil "I" 434mm</p>	<p>Z x8</p>  <p>Batente Injetad PVC</p>	<p>AA x15</p>  <p>Sachê de Cola</p>	<p>AB x6</p>  <p>Adesivo Tapa Parafuso 17mm</p>
<p>AC x78</p>  <p>Adesivo Tapa Parafuso 10mm</p>	<p>AD x3</p>  <p>Giz de Correção</p>	<p>AE x1</p>  <p>Etiqueta Resinada Henn</p>	<p>AF x16</p>  <p>Parafuso 4,5x60mm CHT.</p>
<p>AG x16</p>  <p>Porca Cilindrica.</p>			

PARAFUSOS EM ESCALA 1:1 | TORNILLOS A ESCALA 1:1 | 1:1 SCALE SCREWS

A

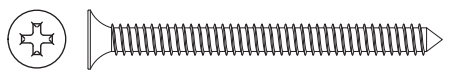

B



C

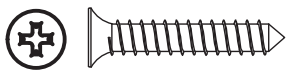

D

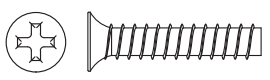

E

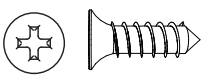

F

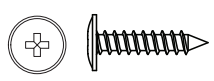

AF



LISTA DE PEÇAS | LISTA DE PIEZAS | LIST OF PIECES

Item	Caixa Caja Box	Qtd Ctd Qty	Descrição Descripción Description	Dimensões (mm) Dimensiones (mm) Dimensions (mm)		
				Comprimento Largo Length	Largura Ancho Width	Espessura Grosor Thickness
1	2/6	1	BASE BASE BASE	2257	480	15
2	1/6	5	TRAVESSA BASE BANDEJA BASE BASE CROSSBOARD	430	70	15
3=21	2/6	1	MOLDURA FRONTAL MARCO FRONTAL FRONT FRAME	2208	80	25
4	4/6	1	DIVISÃO ESQUERDA DIVISIÓN IZQUIERDA LEFT DIVISION	2170	480	15
5	4/6	1	DIVISÃO DIVISIÓN DIVISION	1741	460	15
6	1/6	2	TAMPO DAS GAVETAS TAPA DEL CAJÓN DRAWER TOP	714	400	15
7	1/6	1	CHÃO DO MALEIRO REPISA SUPERIOR FLOOR OF MALEIRO	1443	460	15
8	1/6	1	RIPA DO MALEIRO TRAVESAÑO SUPERIOR MALEIRO'S LATH	414	73	15
9	4/6	1	DIVISÃO DIREITA DIVISIÓN DERECHA RIGHT DIVISION	2170	480	15
10	2/6	2	PILASTRA DA PORTA PUERTA PILASTRA DOOR PILASTER	2170	80	25
11	2/6	4	RIPA LATERAL RIPA LATERAL SIDE CLAPBOARD	525	80	25
12	2/6	1	TAMPO TAPA TOP	2257	480	15
13	3/6	1	LATERAL ESQUERDA LATERAL IZQUIERDA LEFT SIDE	2200	300	15
14	4/6	4	BASE TAMPO MENOR BASE TAPA MÁS PEQUEÑA SMALLER BASE TOP	480	185	15
15	3/6	1	LATERAL DIREITA LADO DERECHO RIGHT SIDE	2200	300	15
16	2/6	8	FUNDO EXTERNO FONDO EXTERIOR EXTERNAL BOTTOM	2200	43	3
17	2/6	6	APLIQUE APLICAR APPLY	2200	60	15
18	2/6	2	APLIQUE LATERAL APLICAR LADO SIDE APPLY	2200	60	15
19	4/6	4	MOLDURA INFERIOR SUPERIOR MARCO INFERIOR SUPERIOR UPPER LOWER FRAME	510	240	25
20	3/6	8	PRATELEIRA LATERAL ESTANTE LATERAL SIDE SHELF	577	350	15
21=3	2/6	1	MOLDURA FRONTAL MARCO FRONTAL FRONT FRAME	2208	80	25
22	5/6	4	FUNDO MENOR FONDO MÁS PEQUEÑO SMALLER FUND	2195	295	3
23	2/6	4	FUNDO FONDO FUND	2195	360	3
24	1/6	6	FRENTE DE GAVETA FRENTE DE CAJÓN FRONT OF DRAWER	656	170	15
25	1/6	12	LADO DE GAVETA LADO DEL CAJÓN SIDE OF DRAWER	350	122	15
26	1/6	6	FUNDO DE GAVETA RECORTADO FONDO DEL CAJÓN RECORTADO CROPPED DRAWER BOTTOM	620	361	3
27	1/6	6	RIPA DE TRÁS MALLA DETRÁS REAR LATH	639	122	15
28	5/6	2	PORTA ESPELHO PUERTA ESPEJO MIRROR DOOR	2165	430	15
29	6/6	4	ESPELHO ESPEJO MIRROR	1078	425	3
30	5/6	2	PORTA PUERTA DOOR	2190	367	15
31	5/6	2	PORTA USINADA PUERTA MECANIZADO MACHINED DOOR	2190	345	15

VISTA EXPLODIDA DAS PEÇAS | VISTA DESPIECE DE LAS PIEZAS | EXPLODED VIEW OF THE PARTS.

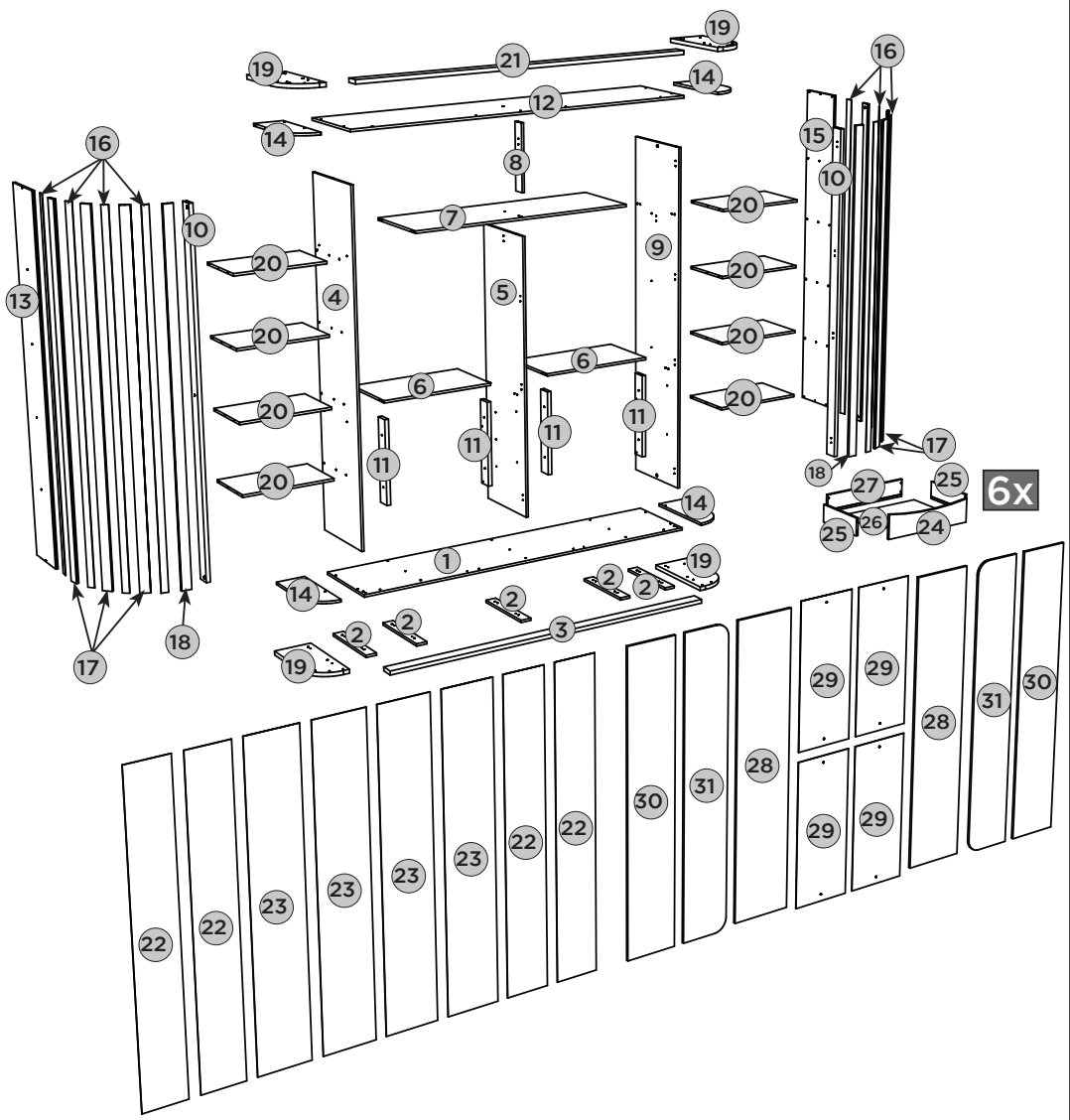

REQUISITOS PARA MONTAGEM
REQUISITOS PARA LA MONTAGE | ASSEMBLY REQUIREMENTS.

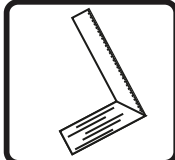
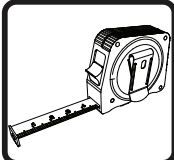
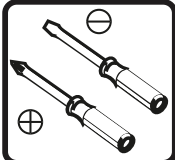
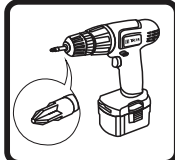





Imagens meramente ilustrativas, não acompanha o produto.
 Imágenes ilustrativas, no incluidas con el producto.
 Illustrative images, not included with the product.

PEÇAS REQUERIDAS

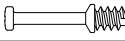
1	BASE	x1
4	DIVISÃO ESQUERDA	x1
5	DIVISÃO	x1

ACESSÓRIOS REQUERIDOS

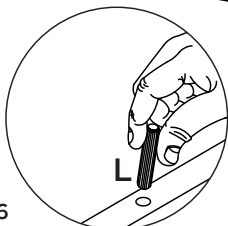
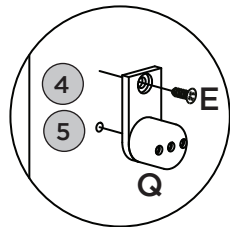
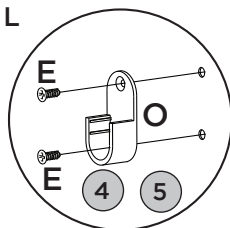
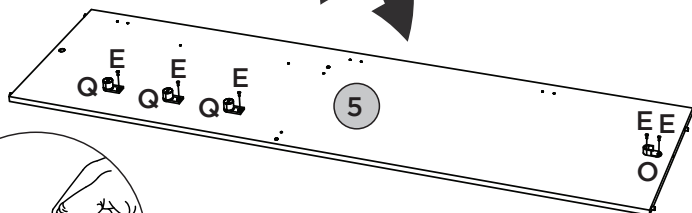
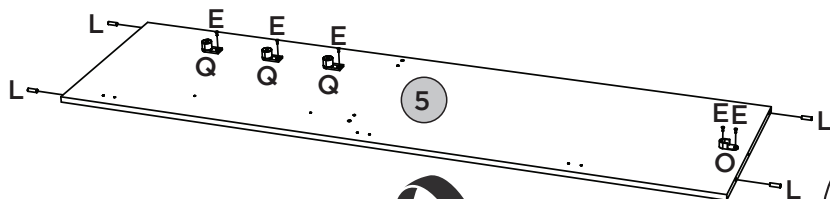
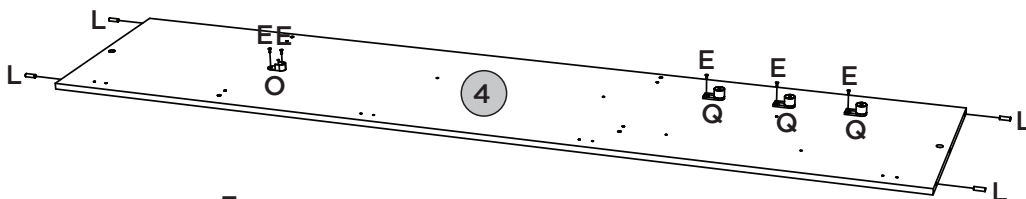
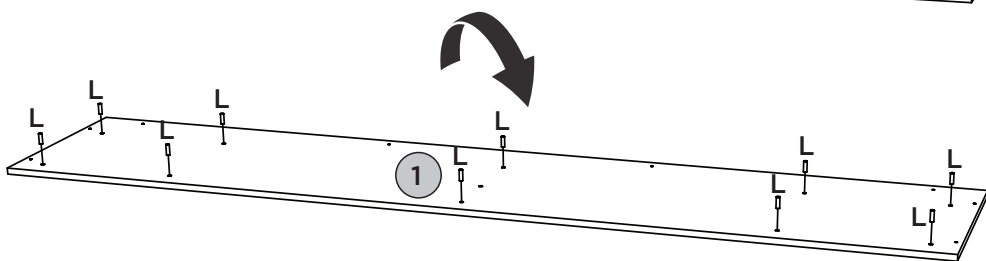
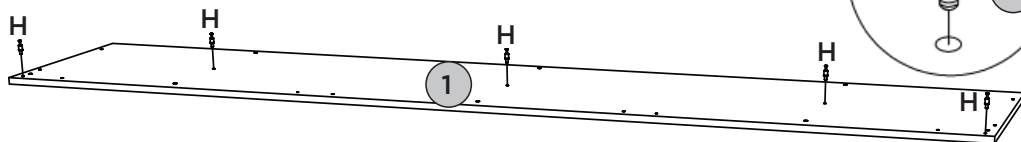
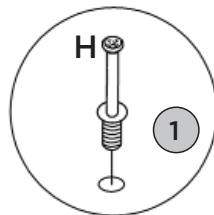
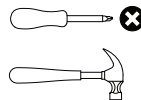

E		15
H		05
L		18
O		03
Q		09

FERRAMENTAS NECESSÁRIAS

PEÇAS REQUERIDAS

6	TAMPO DAS GAVETAS	x2
8	RIPA DO MALEIRO	x1
10	PILASTRA DA PORTA	x2
14	BASE TAMPO MENOR	x4
17	APLIQUE	x6
18	APLIQUE LATERAL	x2

ACESSÓRIOS REQUERIDOS

L		30
AG		16

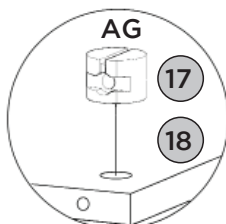
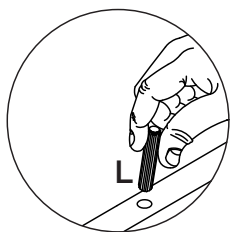
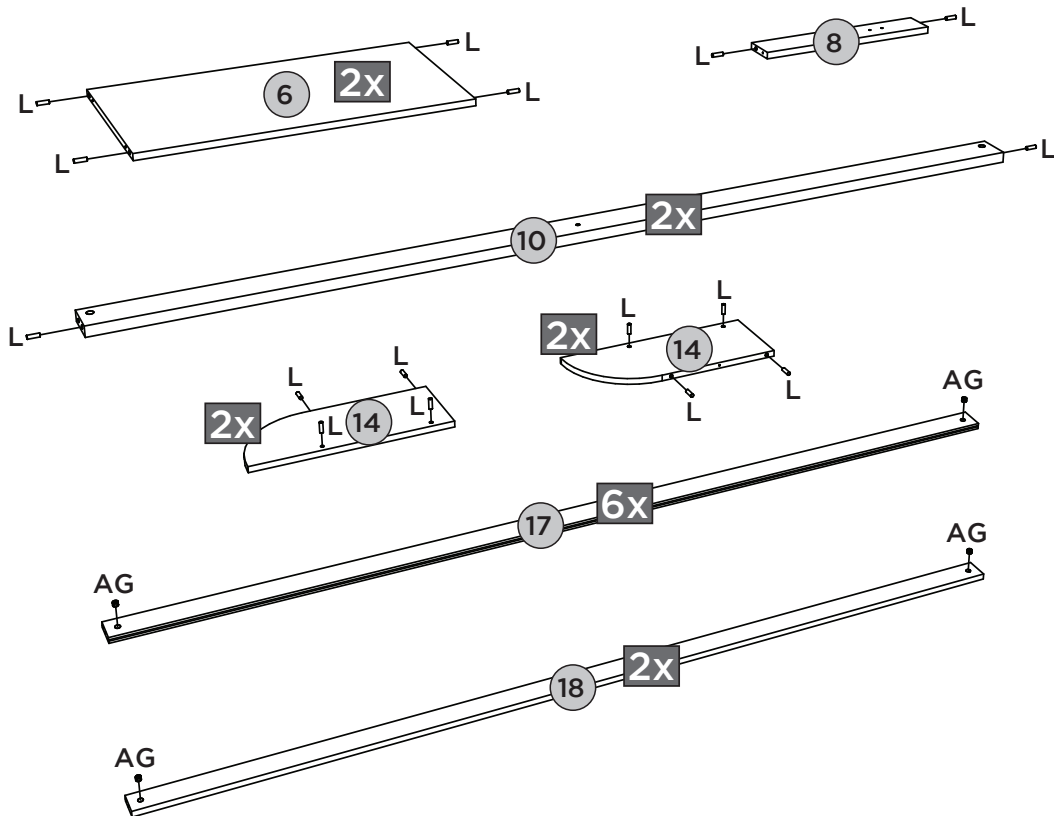
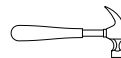
FERRAMENTAS NECESSÁRIAS







PRÉ MONTAGEM | PRE MONTAJE | PRE ASSEMBLY

ITM/D338-

PEÇAS REQUERIDAS

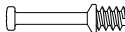
7	CHÃO DO MALEIRO	x1
9	DIVISÃO DIREITA	x1
12	TAMPO	x1
20	PRATELEIRA LATERAL	x8

ACESSÓRIOS REQUERIDOS

E		05
H		04
L		40
O		01
Q		03

FERRAMENTAS NECESSÁRIAS

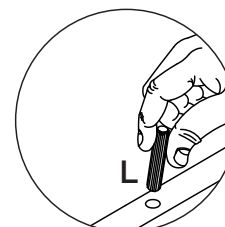
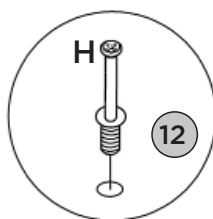
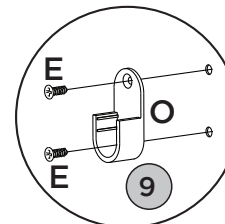
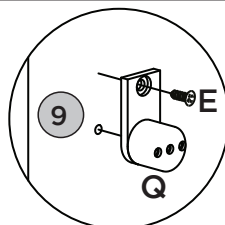
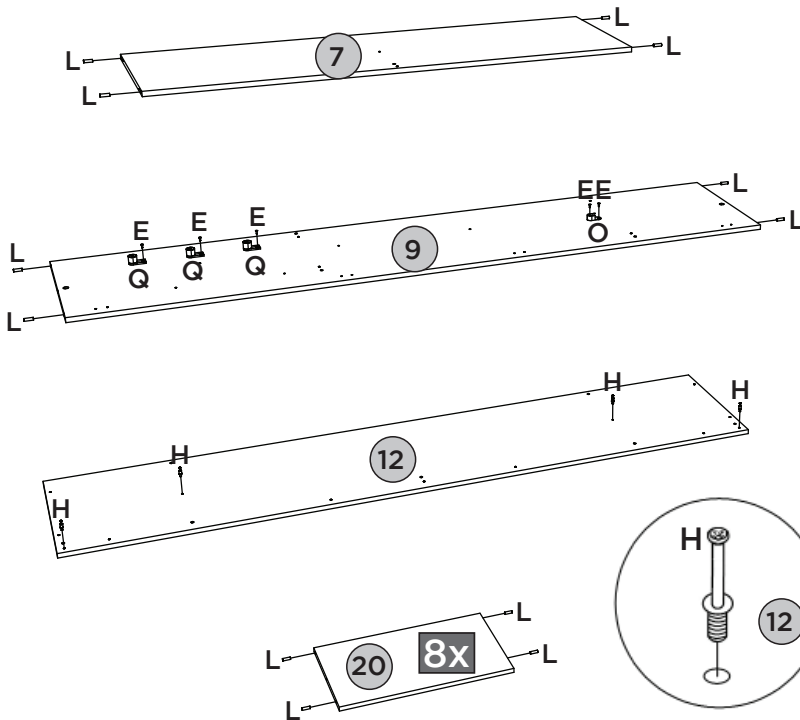
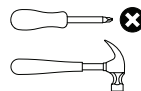



PRÉ MONTAGEM | PRE MONTAJE | PRE ASSEMBLY

PEÇAS REQUERIDAS

25	LADO DE GAVETA	x12
----	----------------	-----

ACESSÓRIOS REQUERIDOS

L		48
AA		



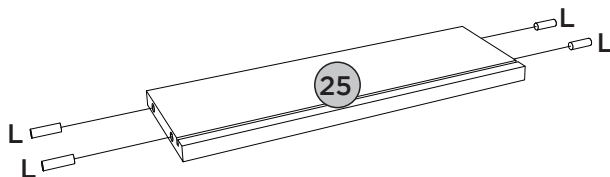
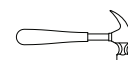

FERRAMENTAS NECESSÁRIAS



PEÇAS REQUERIDAS

28	PORTA ESPELHO	x2
29	ESPELHO	x4
30	PORTA	x2
31	PORTA USINADA	x2

ACESSÓRIOS REQUERIDOS

E		48
F		08
G		08
R		24

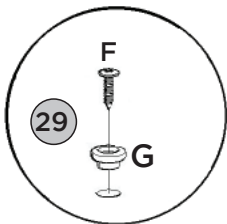
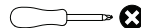
FERRAMENTAS NECESSÁRIAS

Medidas em mm

Medidas en mm

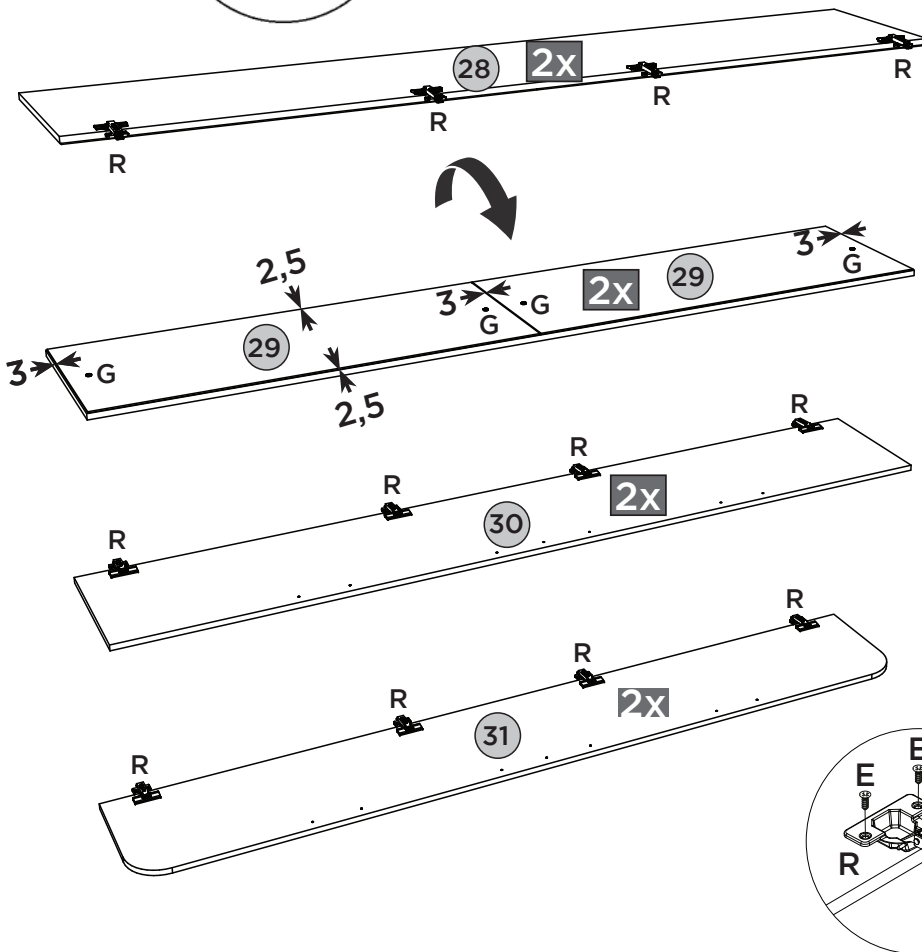

Measurements in mm



PEÇAS REQUERIDAS

1	BASE	x1
2	TRAVESSA BASE	x5
3	MOLDURA FRONTAL	x1

ACESSÓRIOS REQUERIDOS

B		29
C		10
S		10

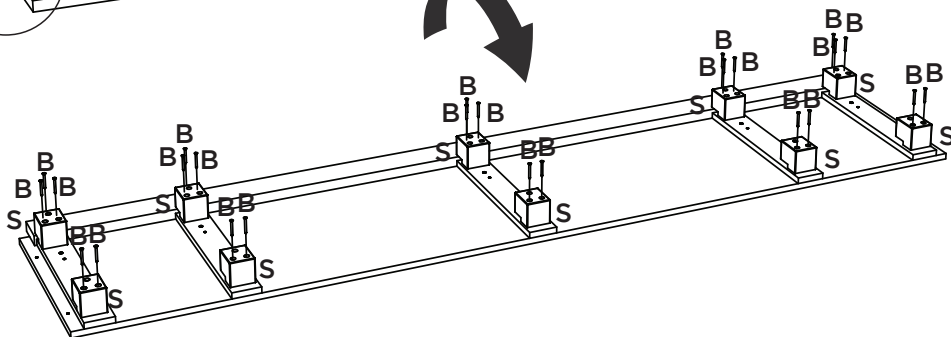
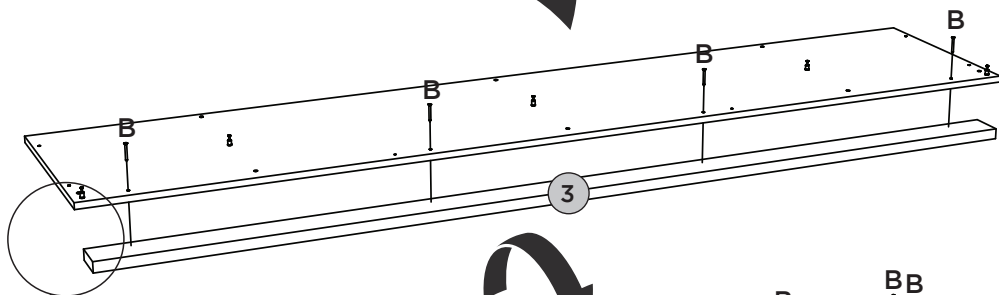
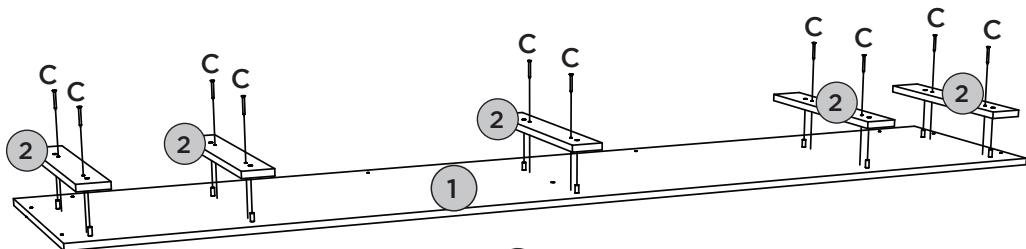
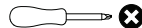

FERRAMENTAS NECESSÁRIAS

24,5mm

PEÇAS REQUERIDAS

4	DIVISÃO ESQUERDA	x1
5	DIVISÃO	x1
6	TAMPO DAS GAVETAS	x2
7	CHÃO DO MALEIRO	x1
8	RIPA DO MALEIRO	x1
9	DIVISÃO DIREITA	x1

ACESSÓRIOS REQUERIDOS

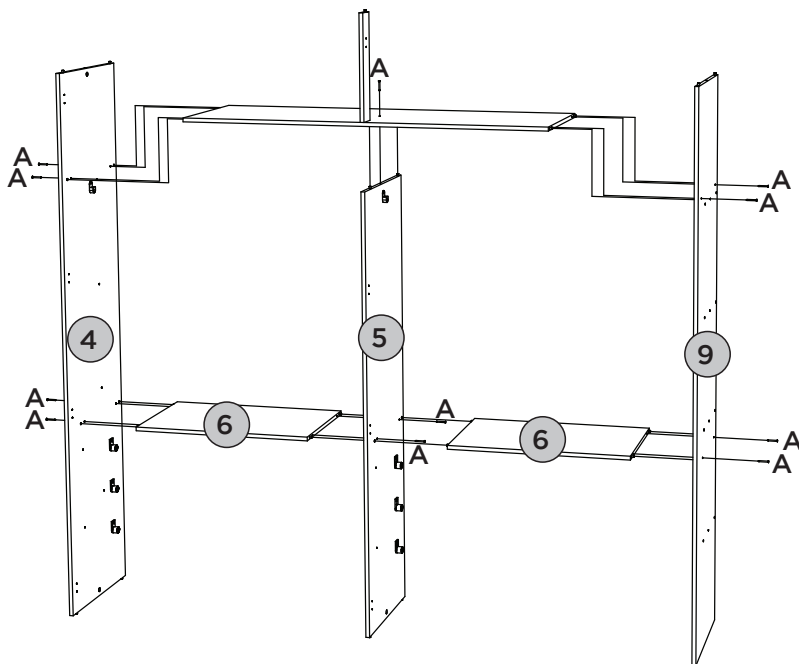
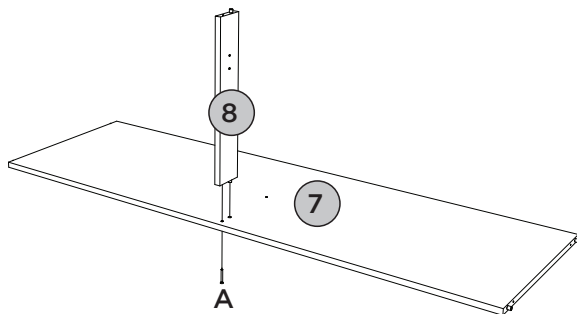
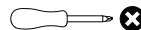

A			12
---	---	---	----

FERRAMENTAS NECESSÁRIAS

PEÇAS REQUERIDAS

10	PILAISTRA DA PORTA	x2
----	--------------------	----

ACESSÓRIOS REQUERIDOS

E		02
I		05
M		01

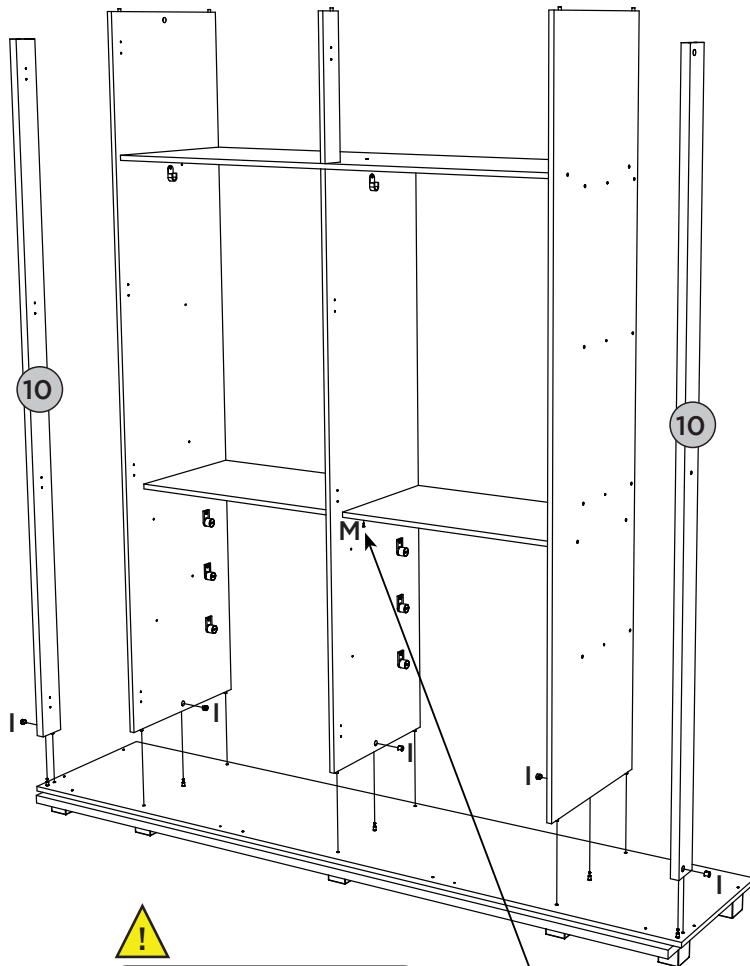
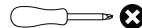
FERRAMENTAS NECESSÁRIAS

Fixar (M) 150mm para dentro, embaixo da peça (6)

Fijar (M) 150mm hacia dentro, debajo de la pieza (6)



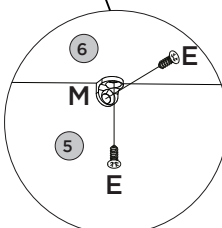
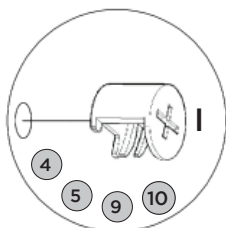

Fix (M) 150mm inwards, under the part (6)



PEÇAS REQUERIDAS

11	RIPA LATERAL	x4
12	TAMPO	x1

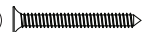
ACESSÓRIOS REQUERIDOS

A			01
B			08
I			04

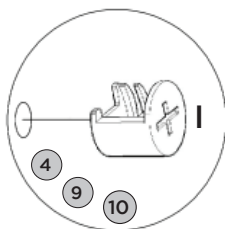
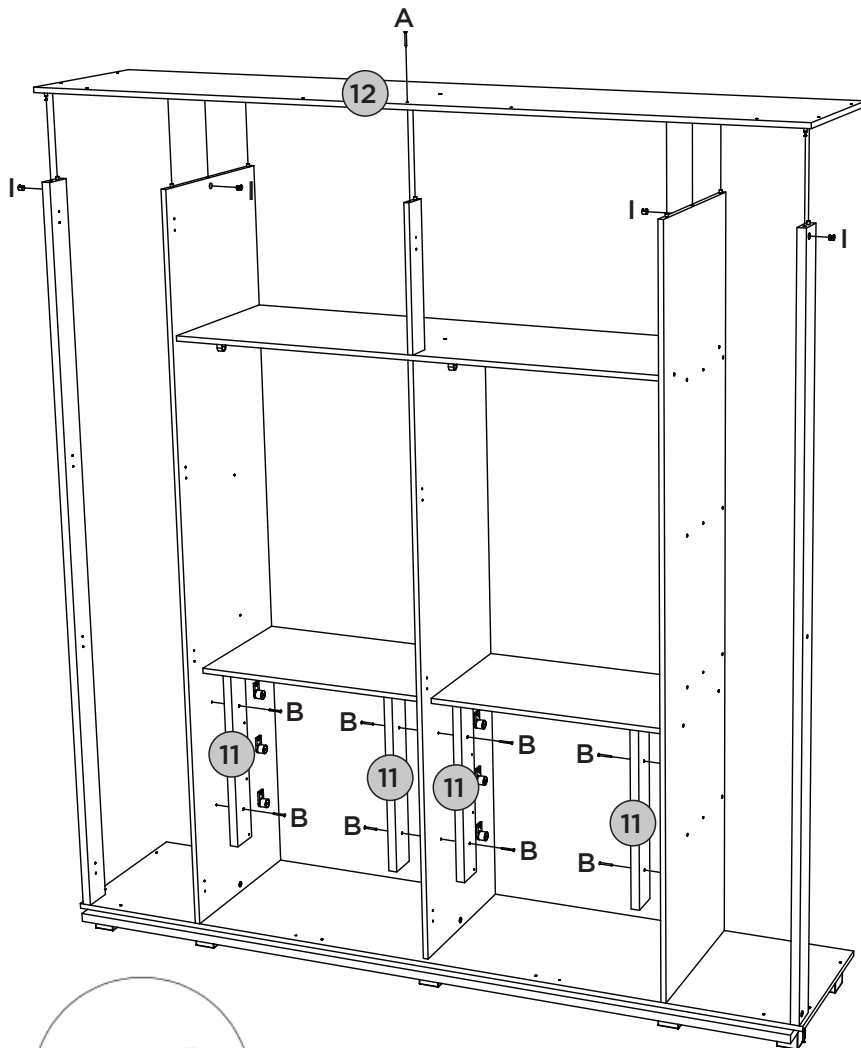
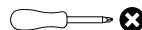
FERRAMENTAS NECESSÁRIAS

PEÇAS REQUERIDAS



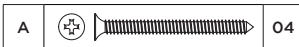
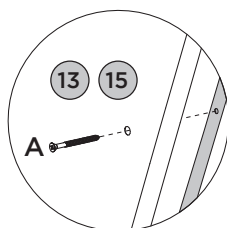
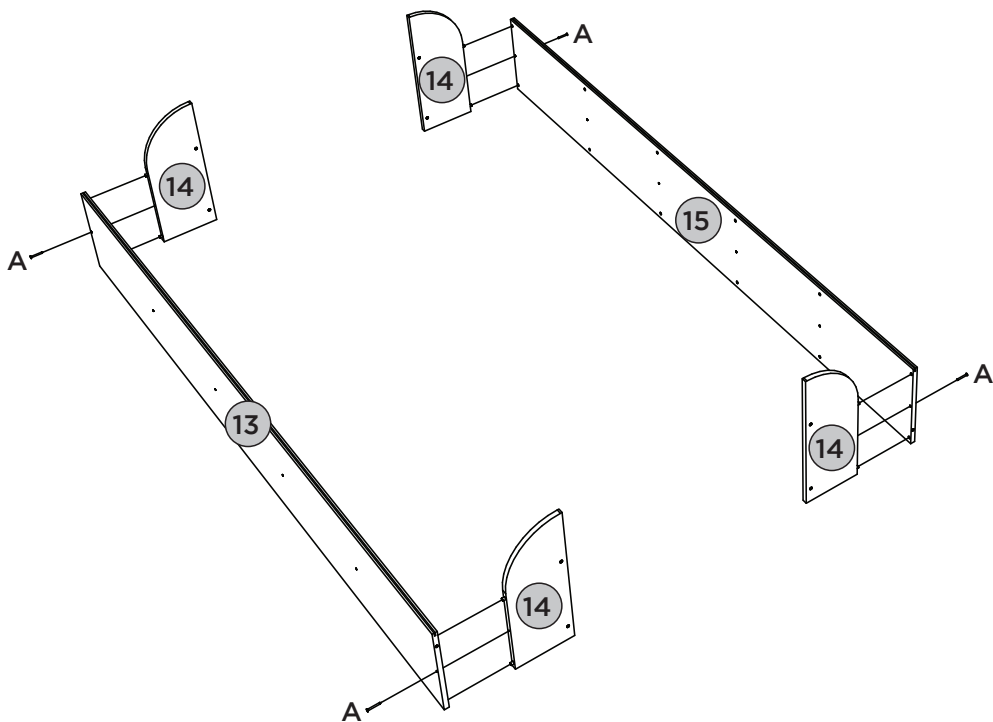
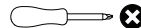



13	LATERAL ESQUERDA	x1
14	BASE TAMPO MENOR	x4
15	LATERAL DIREITA	x1

ACESSÓRIOS REQUERIDOS

FERRAMENTAS NECESSÁRIAS

PEÇAS REQUERIDAS

16	FUNDO EXTERNO	x4
17	APLIQUE	x3
18	APLIQUE LATERAL	x1
19	MOLDURA INFERIOR SUPERIOR	x2

ACESSÓRIOS REQUERIDOS

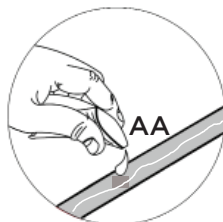
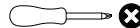
B			10
T			01
AA			
AF			08

FERRAMENTAS NECESSÁRIAS

Aplicar cola nos frisos dos Apliques (17 e 18)

Aplique pegamento a las tiras de apliques (17 y 18)



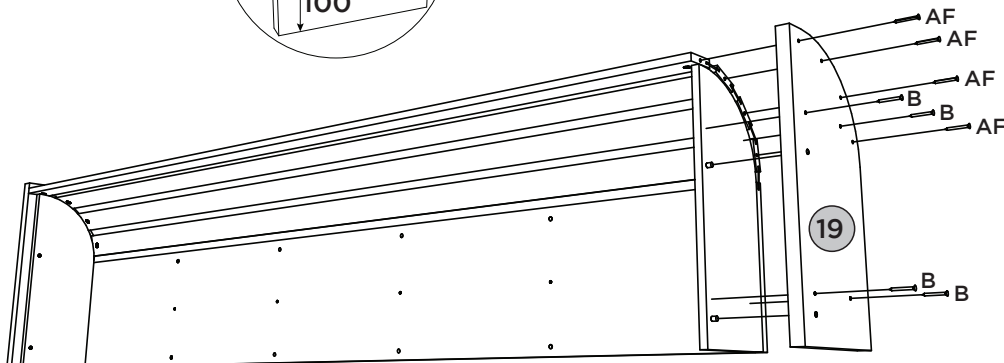
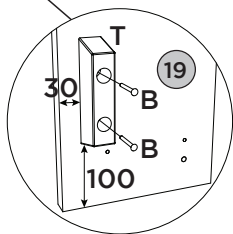
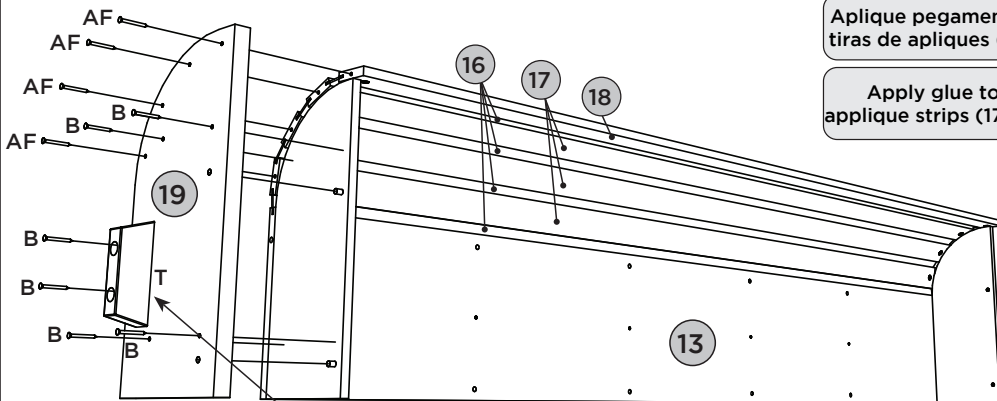

Apply glue to the applique strips (17 and 18)



PEÇAS REQUERIDAS

16	FUNDO EXTERNO	x4
17	APLIQUE	x3
18	APLIQUE LATERAL	x1
19	MOLDURA INFERIOR SUPERIOR	x2

ACESSÓRIOS REQUERIDOS

B		10
T		01
AA		
AF		08

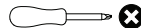
FERRAMENTAS NECESSÁRIAS

Aplicar cola nos frisos dos Apliques (17 e 18)

Aplicar pegamento a las tiras de apliques (17 y 18)



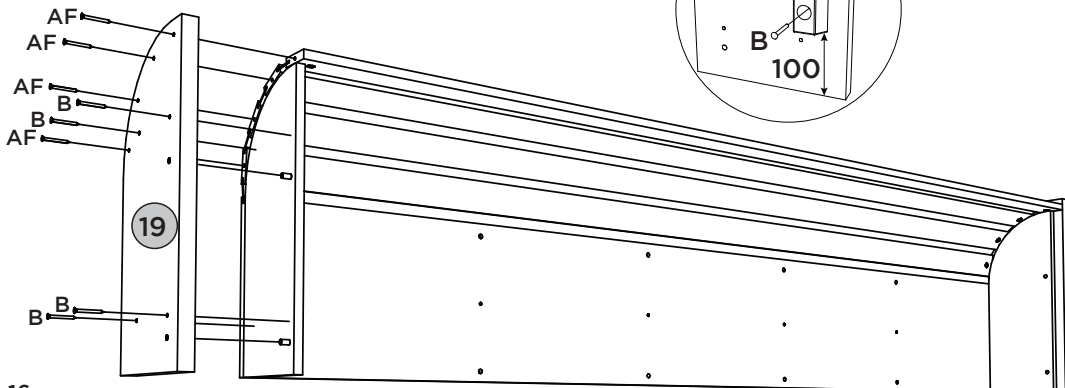
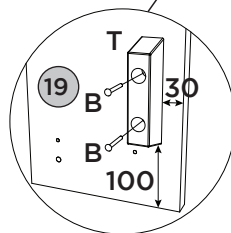
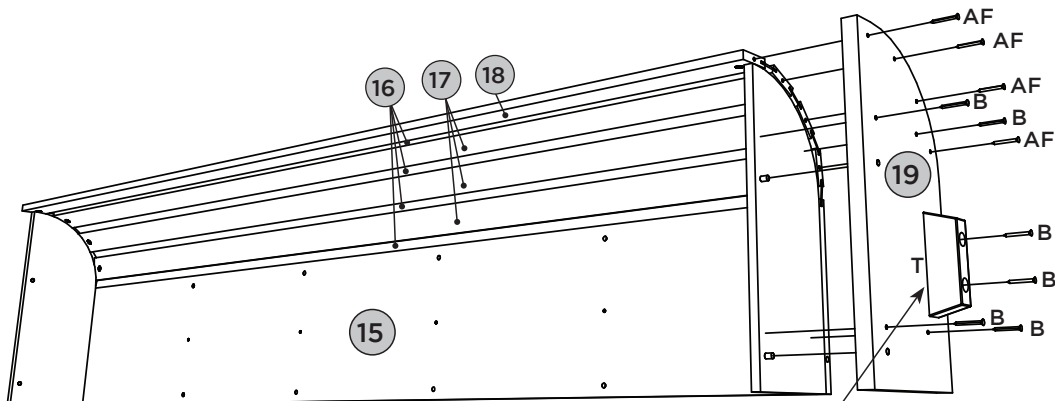





Apply glue to the applique strips (17 and 18)



PEÇAS REQUERIDAS

20	PRATELEIRA LATERAL	x8
----	--------------------	----

ACESSÓRIOS REQUERIDOS



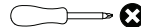
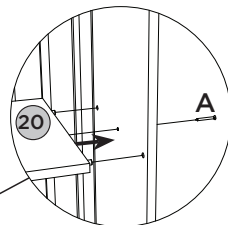
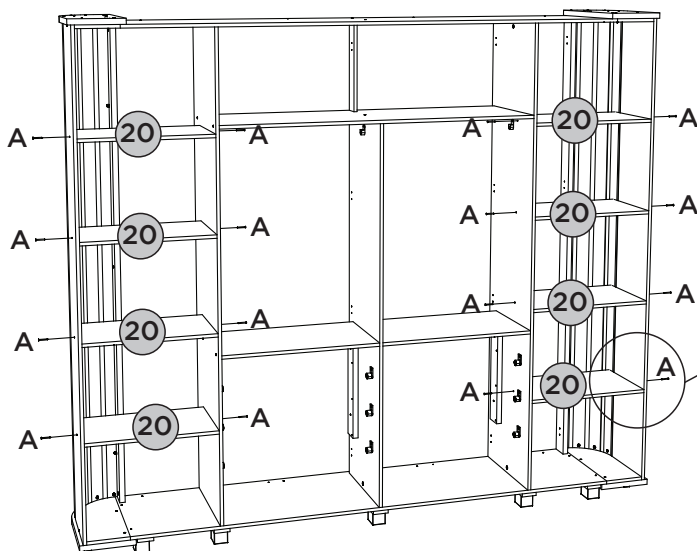
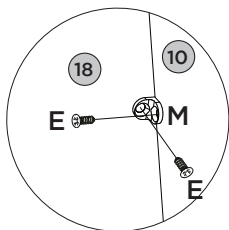
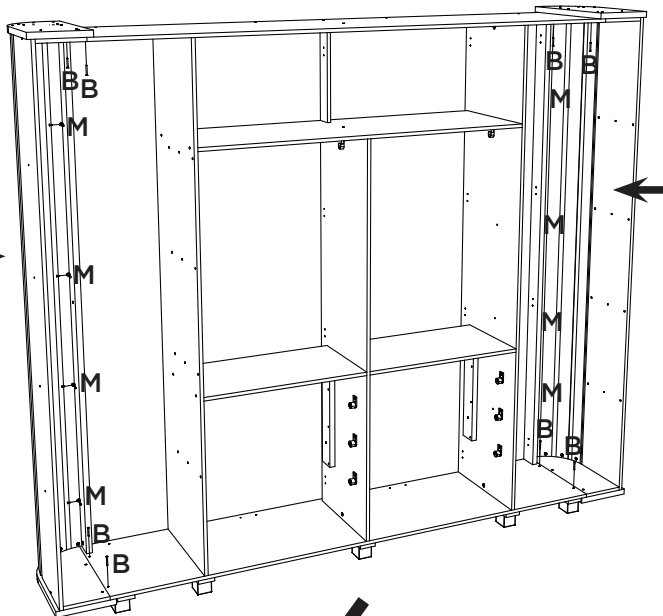



A			16
B			08
E			16
M			08

FERRAMENTAS NECESSÁRIAS

VISTA TRASEIRA

PEÇAS REQUERIDAS

21=3	MOLDURA FRONTAL	x1
------	-----------------	----

ACESSÓRIOS REQUERIDOS

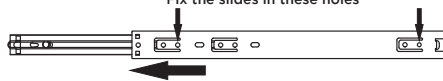
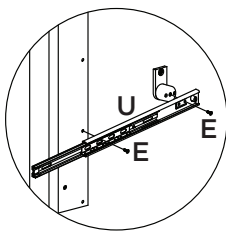
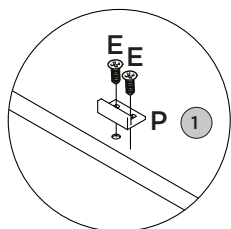
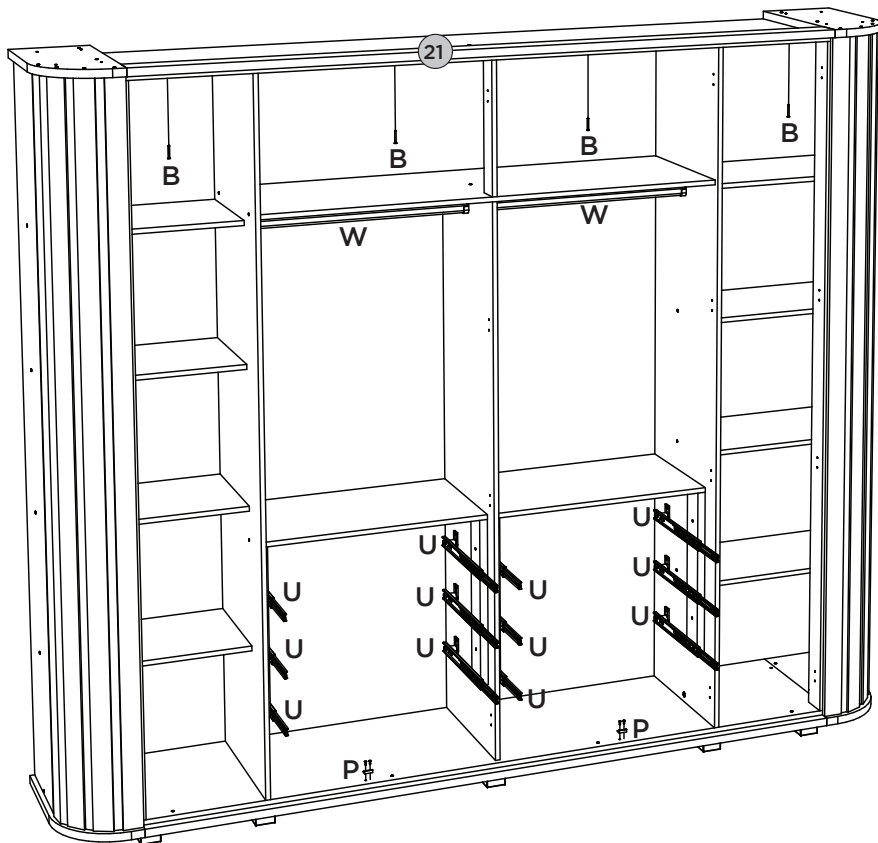
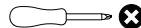
B			04
E			28
P			02
U			12
W			02



FERRAMENTAS NECESSÁRIAS

Fixar as corredeiras nessas furacões
 Fijar las diapositivas de estos agujeros
 Fix the slides in these holes

PEÇAS REQUERIDAS

22	FUNDO MENOR	x4
23	FUNDO	x4

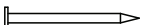
ACESSÓRIOS REQUERIDOS

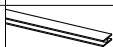
J		239
K		59
X		04
Y		01

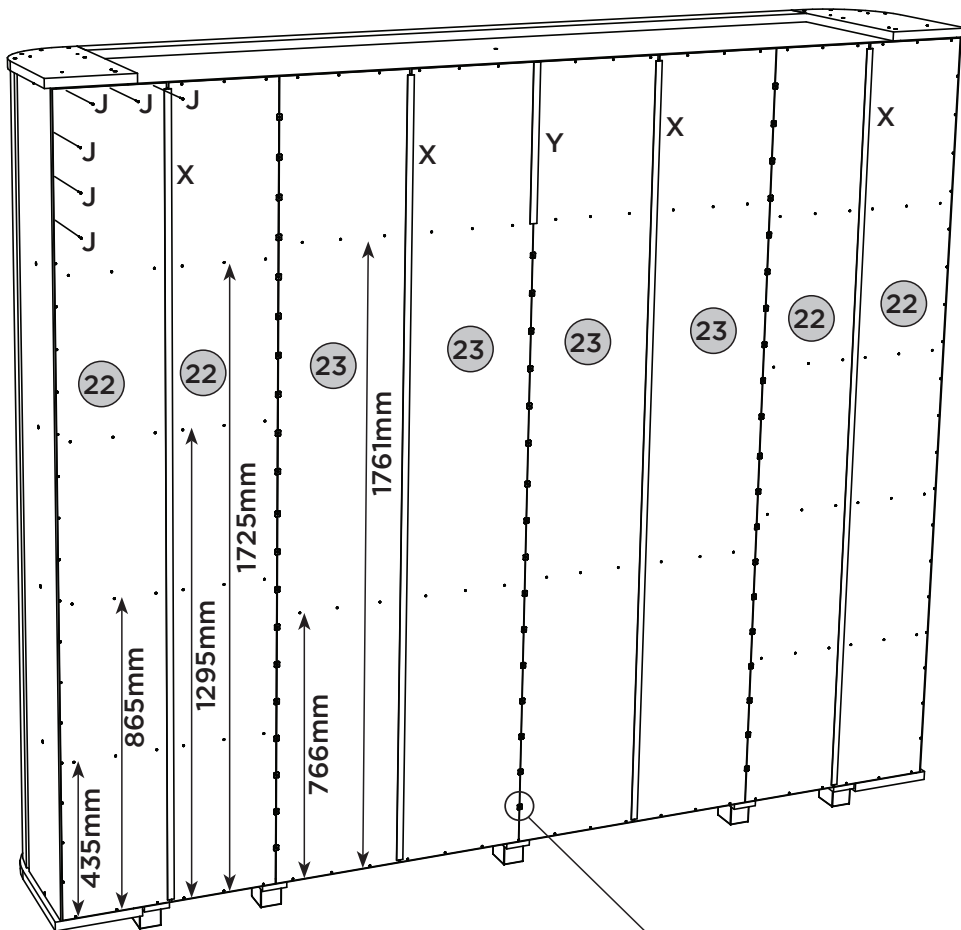
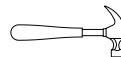
FERRAMENTAS NECESSÁRIAS

Fixar os pregos a uma distância de 100mm de um para outro.

Fijar las uñas a un distancia de 100mm uno a otro.

Fix the nails at a distance of 100mm from one to the other

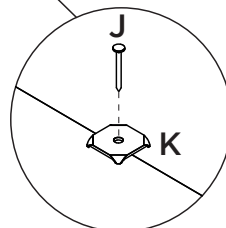

PEÇAS REQUERIDAS

24	FRENTE DE GAVETA	x6
25	LADO DE GAVETA	x12
26	FUNDO DE GAVETA RECORTADO	x6
27	RIPA DE TRÁS	x6

ACESSÓRIOS REQUERIDOS

B			12
E			72
M			12
N			12

FERRAMENTAS NECESSÁRIAS

U			12
AA			

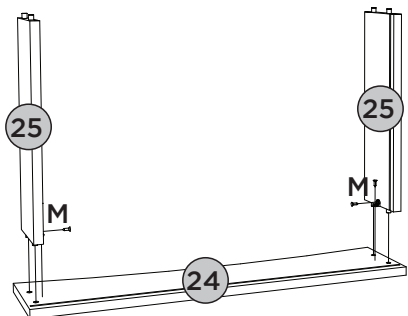
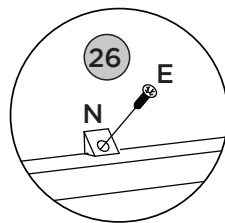
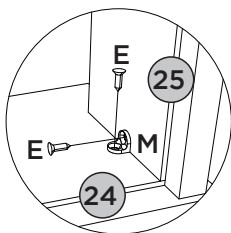
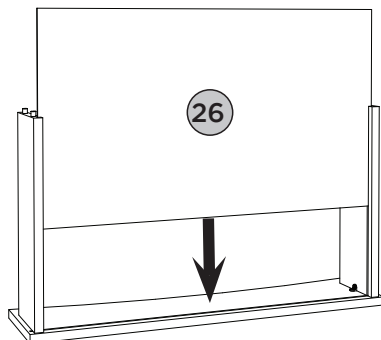
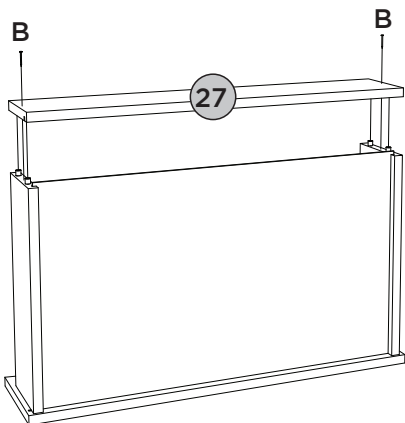
1º
6x

2º
6x

3º
6x

4º
6x

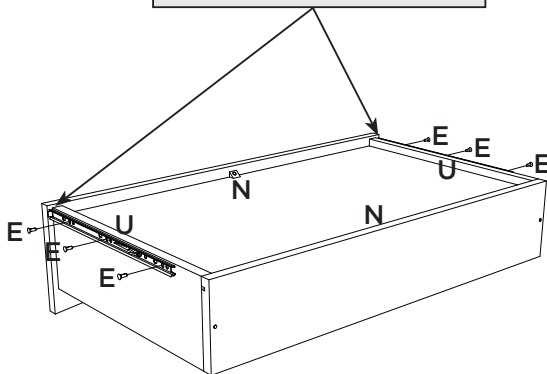
Deixar 3mm de distância da frente de gaveta.

Deje una separación de 3mm del frente del cajón.



Leave 3mm away from the front of the drawer.



PEÇAS REQUERIDAS

28	PORTA ESPELHO	x2
29	ESPELHO	x4

ACESSÓRIOS REQUERIDOS



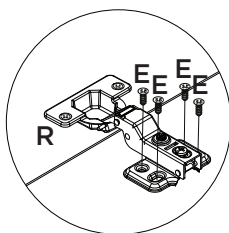
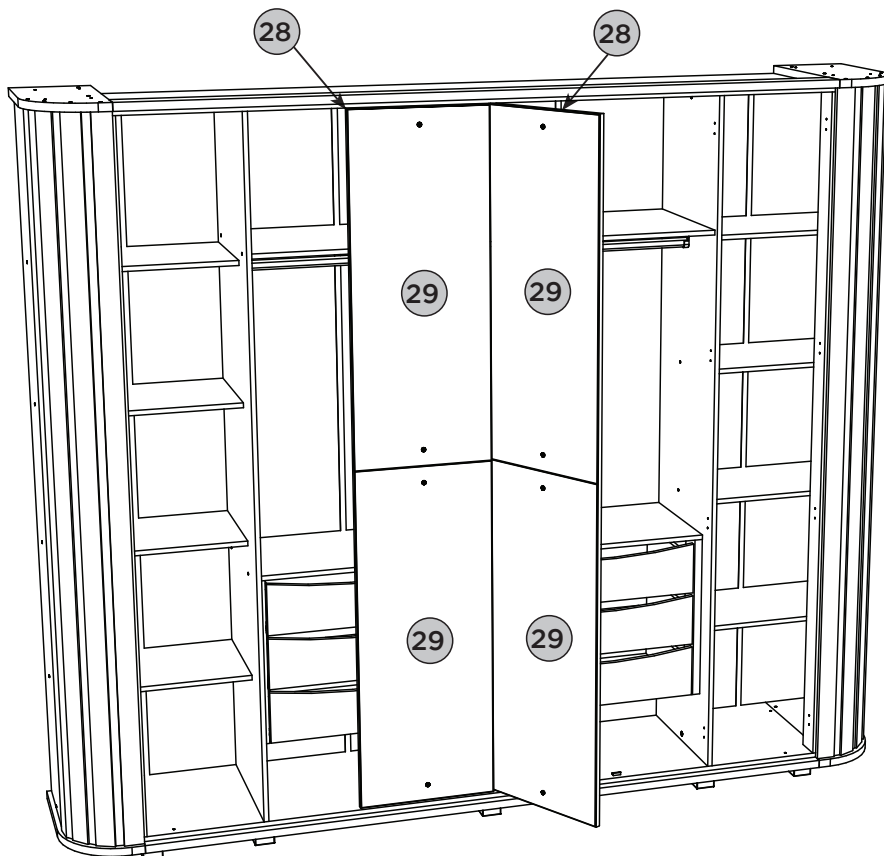
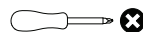



E			32
---	---	---	----

FERRAMENTAS NECESSÁRIAS

PEÇAS REQUERIDAS

30	PORTA	x2
31	PORTA USINADA	x2

ACESSÓRIOS REQUERIDOS

D			16
E			64
V			04
Z			08

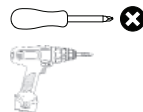
FERRAMENTAS NECESSÁRIAS



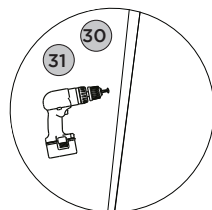
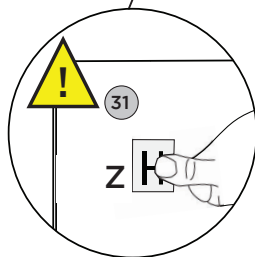
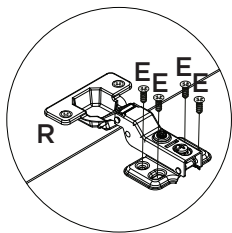
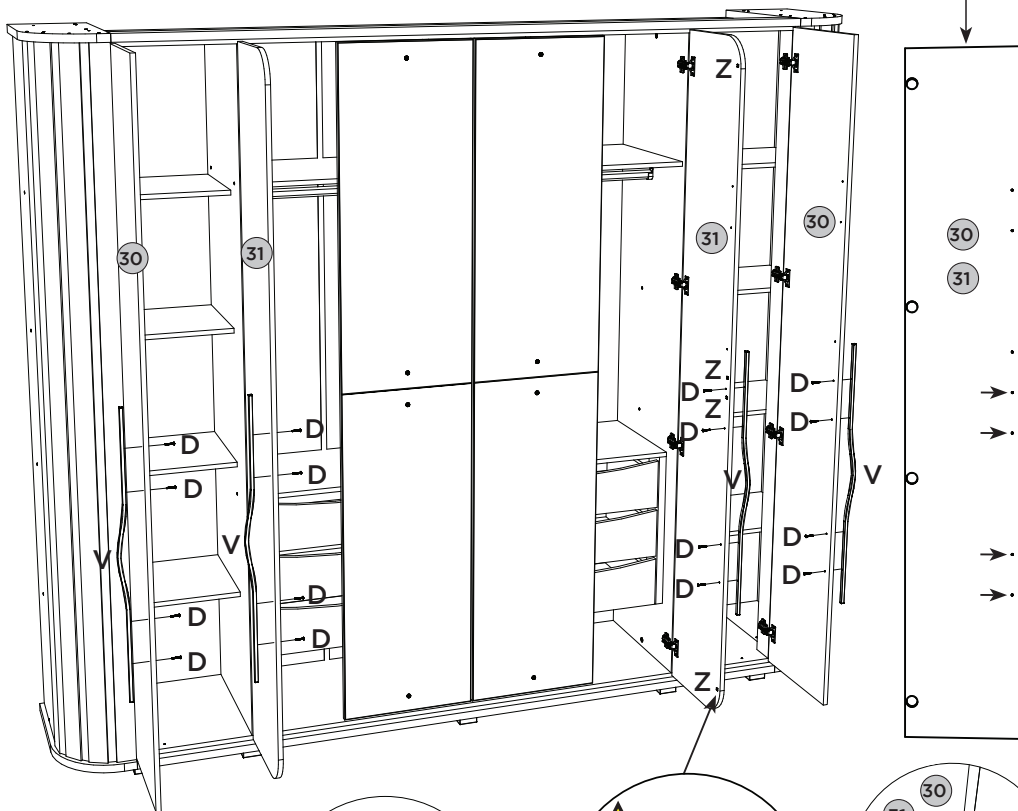

Portas (30 e 31): Para fixar o puxador (V) é necessário realizar a furação passante com uma broca de 6mm, utilizando as marcações abaixo.

Puertas (30 y 31): Para fijar el tirador (V) es necesario realizar agujeros pasantes con una broca de 6 mm, siguiendo las marcas siguientes.

Doors (30 and 31): To fix the handle (V) it is necessary to drill through holes with a 6mm drill bit, using the markings below.



ACESSÓRIOS REQUERIDOS

AB		06
AC		78
AD		03
AE		01

Pesos máximos recomendados com carga distribuída
Peso máximo recomendado con la carga distribuida
Recommended maximum weight with distributed load.

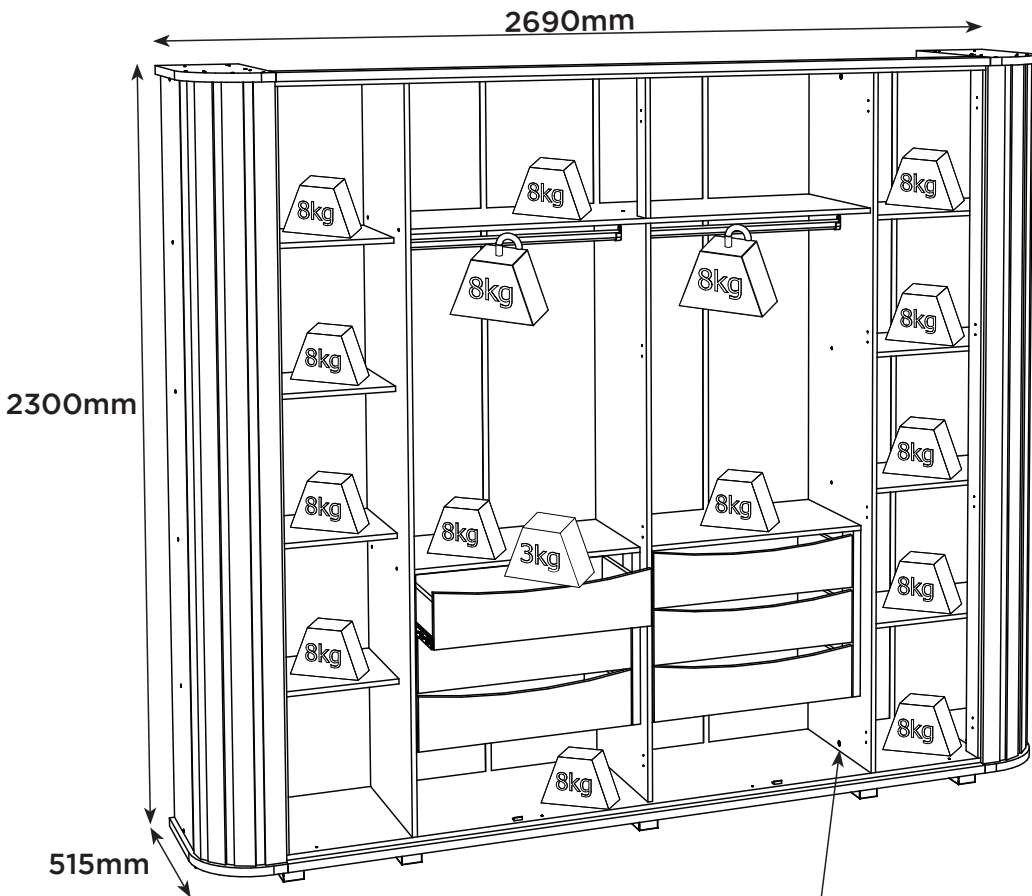

PERFECT CORRECTION
CORRECCIÓN PERFECTA

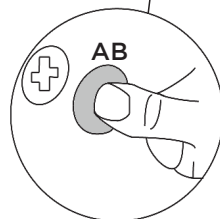
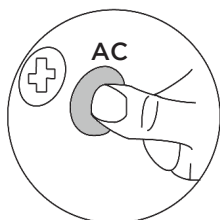
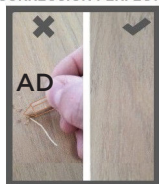

PRODUTO CONCLUÍDO
PRODUCTO TERMINADO
FINISHED PRODUCT

