

ASSEMBLY INSTRUCTIONS MANUAL DE MONTAGEM / INSTRUCCIONES DE ARMADO

Reference
Referência
Referencia

Revise
Revisão
Revisión

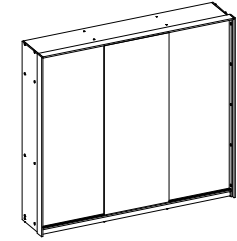

YOU WILL NEED VOCÊ VAI PRECISAR DE / USTED NECESITARÁ

Tools not supplied
Ferramentas não fornecidas / Herramientas no incluidas

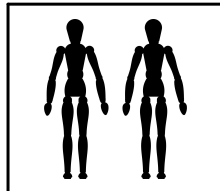

2 People
2 Pessoas
2 Personas

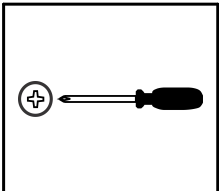

Screwdriver Phillips
Chave Phillips
Destornillador cruz

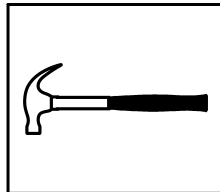

Hammer
Martelo
Martillo

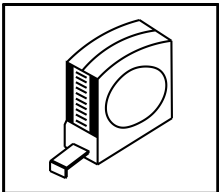

Measuring tape
Trena
Cinta de medición

PARTS IDENTIFICATION IDENTIFICAÇÃO DAS PEÇAS / IDENTIFICACIÓN DE LAS PIEZAS

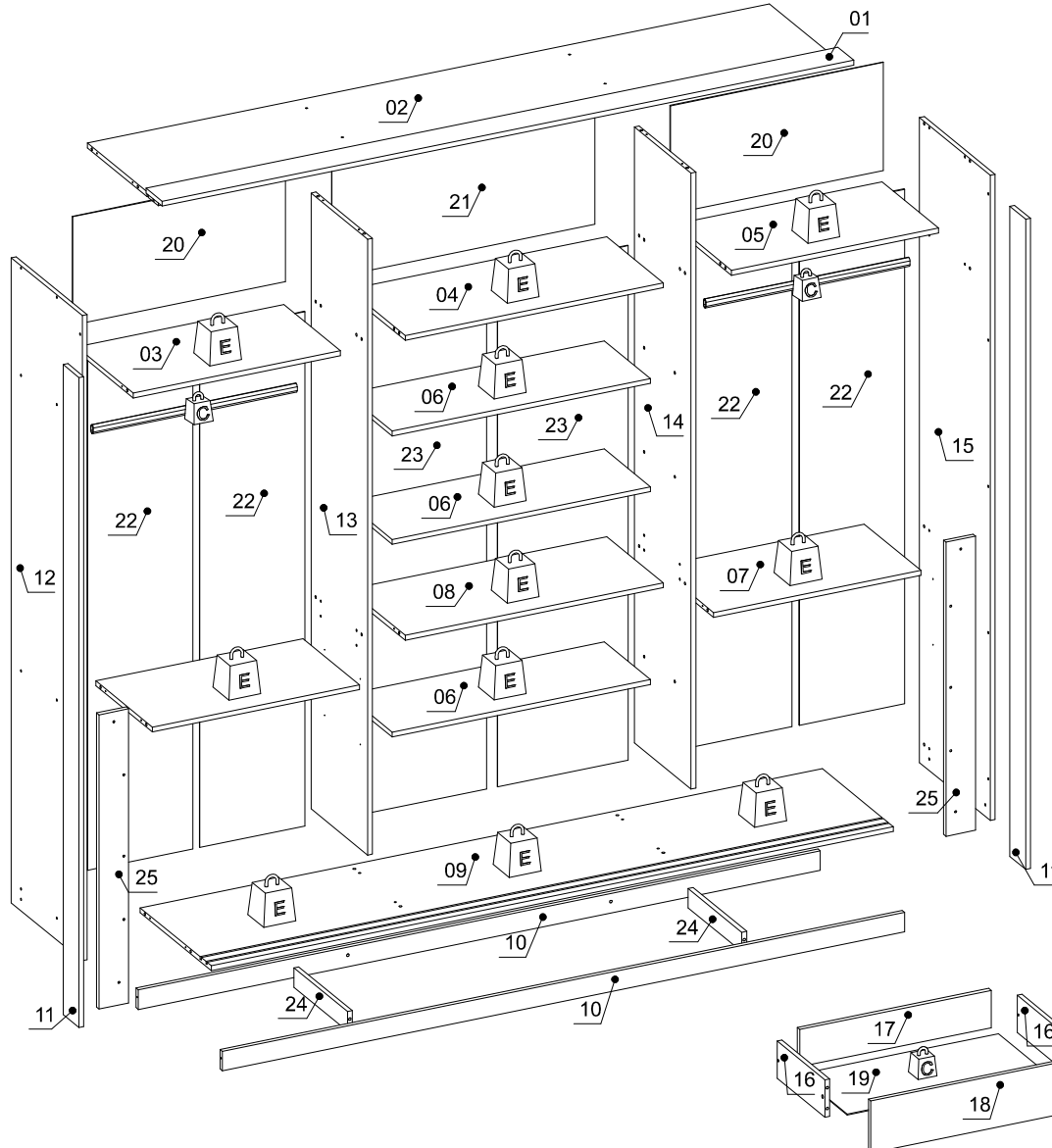

Nº	Measures_Inches	Medidas_cm	Qty./Qtd.
01	85 3/8 x 3 7/8 x 5/8	217.0 x 10.0 x 1.5	1
02	84 1/4 x 17 1/2 x 5/8	214.0 x 44.5 x 1.5	1
03	25 5/8 x 14 x 5/8	65.0 x 35.5 x 1.5	1
04	31 7/8 x 14 x 5/8	81.0 x 35.5 x 1.5	1
05	25 5/8 x 14 x 5/8	65.0 x 35.5 x 1.5	1
06	31 7/8 x 11 3/8 x 5/8	81.0 x 29.0 x 1.5	3
07	25 5/8 x 14 x 5/8	65.0 x 35.5 x 1.5	2
08	31 7/8 x 14 x 5/8	81.0 x 35.5 x 1.5	1
09	84 1/4 x 17 1/2 x 5/8	214.0 x 44.5 x 1.5	1
10	84 1/4 x 2 3/8 x 5/8	214.0 x 6.0 x 1.5	2
11	78 3/4 x 3 7/8 x 5/8	200.0 x 10.0 x 1.5	2
12	78 1/8 x 17 1/2 x 5/8	198.5 x 44.5 x 1.5	1
13	74 5/8 x 14 x 5/8	189.5 x 35.5 x 1.5	1
14	74 5/8 x 14 x 5/8	189.5 x 35.5 x 1.5	1
15	78 1/8 x 17 1/2 x 5/8	198.5 x 44.5 x 1.5	1
16	11 3/4 x 4 1/2 x 5/8	30.0 x 11.5 x 1.5	8
17	23 5/8 x 4 1/2 x 5/8	60.1 x 11.5 x 1.5	4
18	25 1/4 x 6 1/4 x 5/8	64.1 x 16.0 x 1.5	4
19	24 5/8 x 12 x 1/8	62.7 x 30.5 x 0.3	4
20	26 1/4 x 13 1/8 x 1/8	66.8 x 33.3 x 0.3	2
21	32 1/2 x 13 1/8 x 1/8	82.5 x 33.3 x 0.3	1
22	62 3/8 x 13 x 1/8	158.3 x 33.0 x 0.3	4
23	62 3/8 x 16 1/8 x 1/8	158.3 x 40.9 x 0.3	2
24	2 3/8 x 13 1/4 x 5/8	6.0 x 33.7 x 1.5	2
25	35 5/8 x 3 5/8 x 5/8	90.5 x 9.3 x 1.5	2

MAXIMUM RECOMMENDED WEIGHT BEING THIS EVENLY DISTRIBUTED.
PESO MÁXIMO RECOMENDADO SENDO ESTE DISTRIBUÍDO UNIFORMEMENTE.
PESO MÁXIMO RECOMENDADO SIENDO ESTE UNIFORMEMENTE DISTRIBUIDO.

	LB	KG
C	6	3
E	17	8

IDENTIFICATION OF ACCESSORIES

IDENTIFICAÇÃO DOS ACESSÓRIOS/ IDENTIFICACIÓN DE ACCESORIOS

The separation of the accessories before you start the assembly will facilitate the same. In case of doubt on the size of the screws and bolts, use the ruler at the bottom of the page.

A separação dos acessórios antes de iniciar a montagem facilitará a mesma. Em caso de dúvida no tamanho dos parafusos e cavilhas, utilize a régua ao final da página.

La separación de los accesorios antes de comenzar el armado facilitará el mismo. En caso de duda sobre el tamaño de los tornillos y taquetes, utilice la regla al pie de página.



A2		Small plastic foot Sapata redonda / Pie plástico	14 mm	8
A3		Trapeze Trapézio / Trapecio	-	8
A6		"H" profile Perfil "H" / Perfil "H"	-	3
B5		Metalic angle plates Cantoneira de metal / Soporte de metal	46 mm	8
C1		Metal claw Garra de metal / Garra metal	-	36
D		Flat head screw Parafuso chato / Tornillo de cabeza plana	4,0x40 mm	8
E		Wooden dowel Cavilha / Taquete	8x30 mm	52
E3		Shelf bracket Suporte de prateleira / Soporte de repisa	8x7 mm	12
F		Wooden dowel Cavilha / Taquete	8x50 mm	4
H29A		Top guide Guia superior / Guia superior	-	6
H29B		Bottom guide Guia inferior / Guia inferior	-	6
H29C		Flanged head screw Parafuso flangeado / Tornillo de cabeza flangeada	3,5x10 mm	36
K		Double minifix screw Haste minifix dupla / Tornillo minifix doble	60mm	4
K10		Telescopic slide Corrediça telescópica / Corredera telescópica	300 mm	8
L		Drum lock Tambor minifix / Tambor minifix	12 mm	8
L9		Flat head screw Parafuso chato / Tornillo de cabeza plana	3,5x12 mm	48
M		Bore patch adhesive Tapa furo adesivo / Tapones adhesivo	-	45
M1		Flat head screw Parafuso chato / Tornillo de cabeza plana	3,5x25 mm	25
M19		Sliding door rail Trilho porta de correr / Carril puerta deslizando	-	4
N		Nail Prego / Clavo	10x10	197
O		Flat head screw Parafuso chato / Tornillo de cabeza plana	4,5x45 mm	36
P		Pan head screw Parafuso panela / Tornillo de pan	4,5x25 mm	8
Q3		Clothes rack Cabideiro tubo / Perchero	Medida	2
Q9		Clothes rack support Suporte cabideiro / Soporte perchero	-	4
S		Pan head screw Parafuso panela / Tornillo de pan	3,5x14 mm	32



PRE-ASSEMBLE PRÉ-MONTAGEM / PRE ARMADO

01

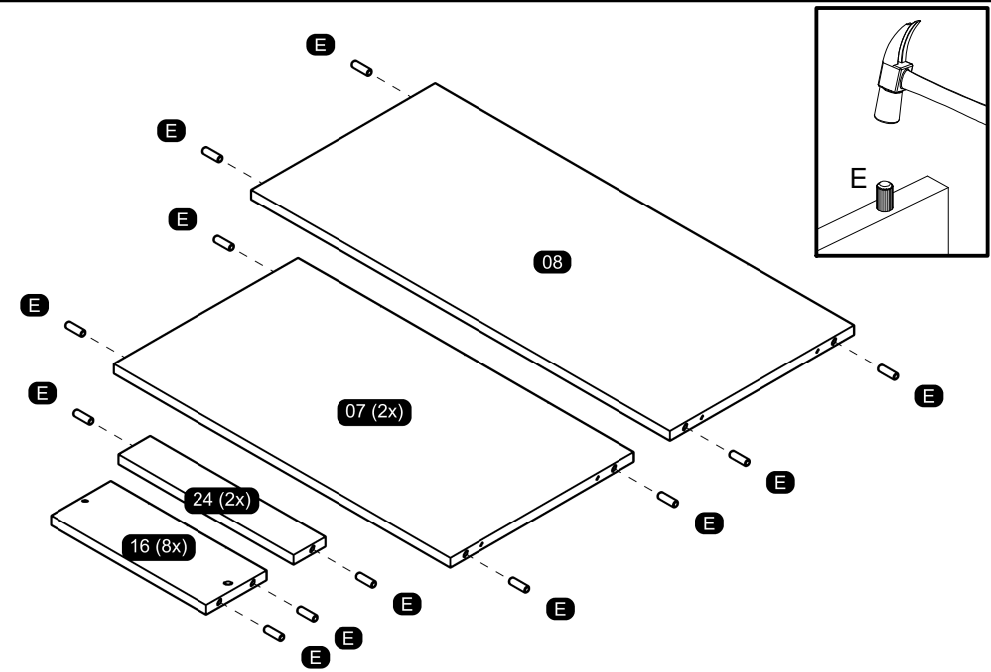

02

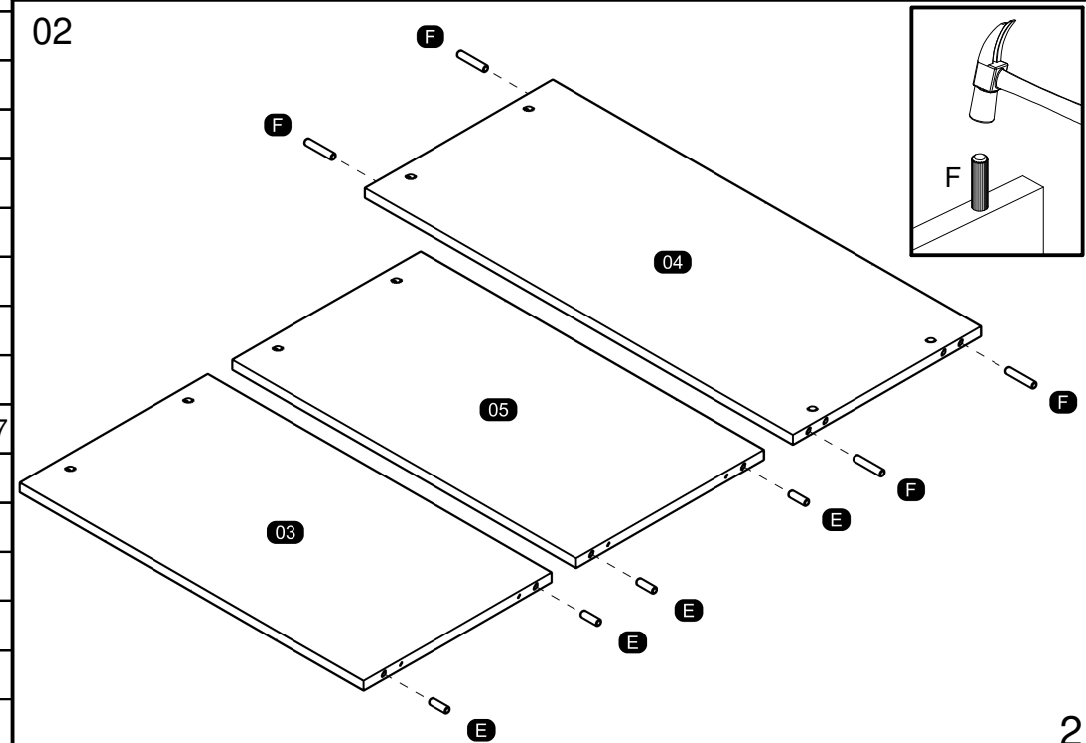

03

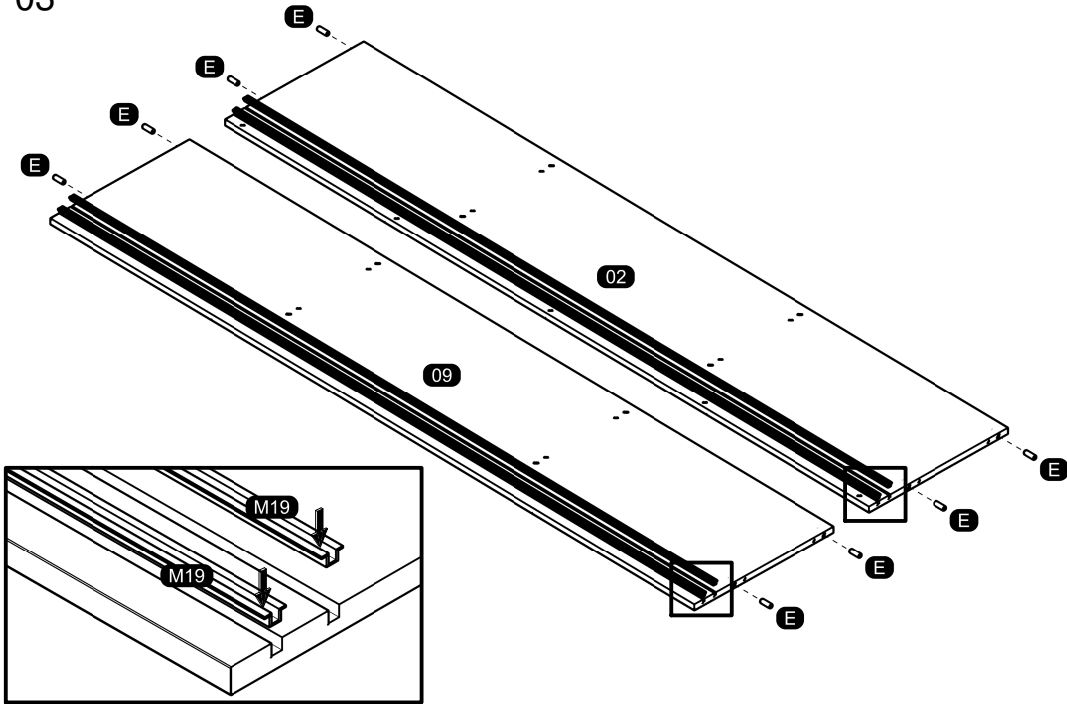

05

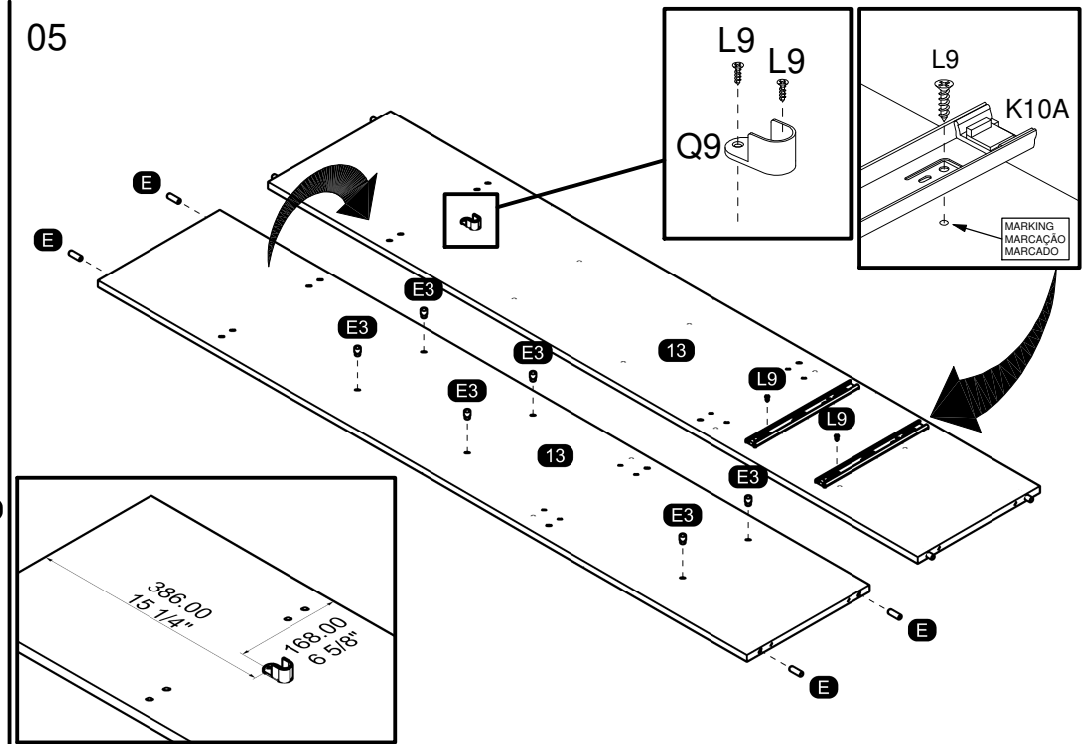

04

SEPARATE THE TWO PARTS OF THE METAL SLIDE TO THE ASSEMBLY FOLLOWING THE INSTRUCTIONS BELOW.
 SEPARARE AS DUAS PARTES DA CORREDEIRA METÁLICA PARA A MONTAGEM SEGUINDO AS INSTRUÇÕES ABAIXO.
 SEPARAR LAS DOS PARTES DE LA CORREDERA DE METAL PARA EL ARMADO Y SEGUIR LAS INSTRUCCIONES ABAJO.

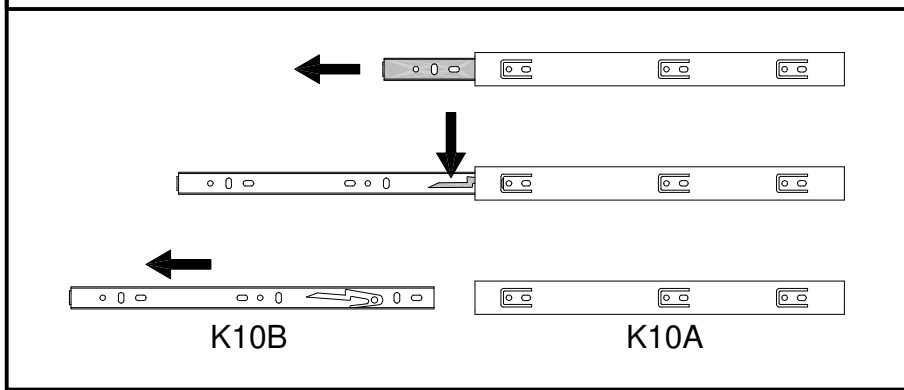

06

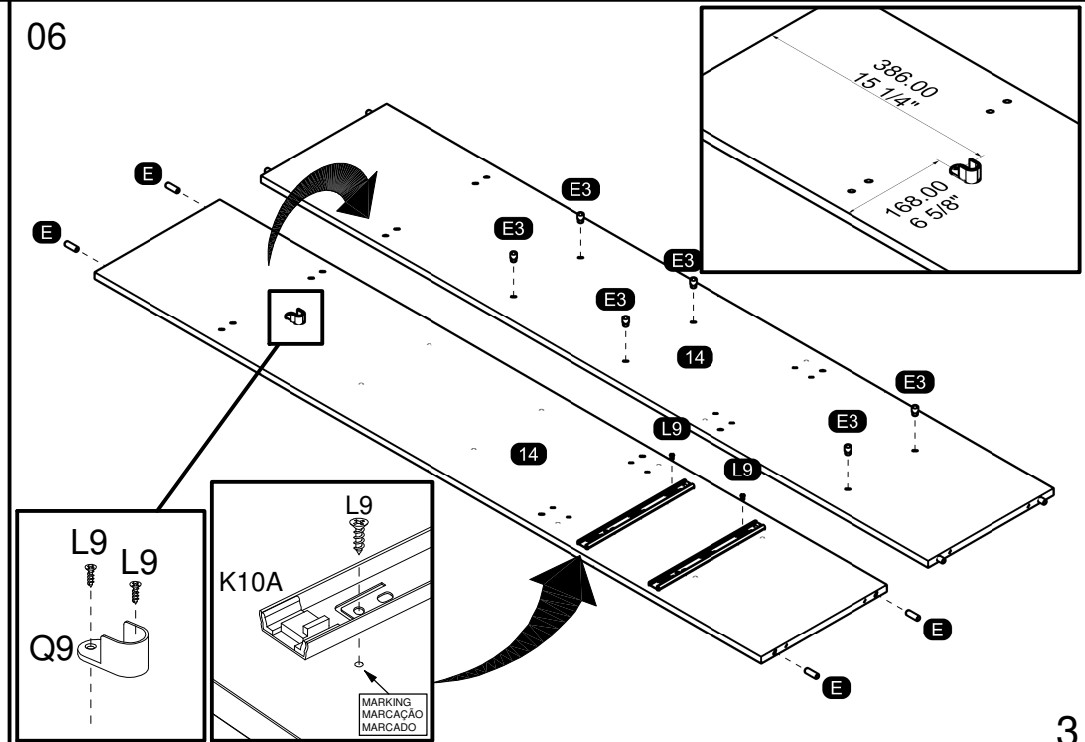

07

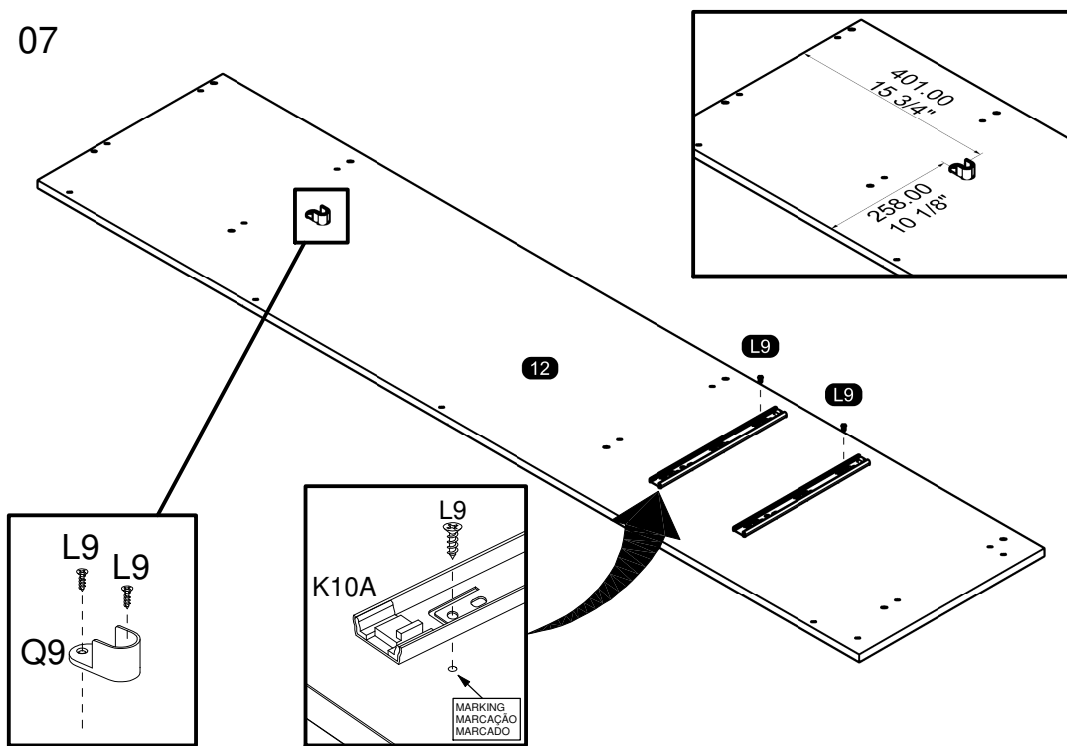

ASSEMBLY MONTAGEM / ARMADO

09

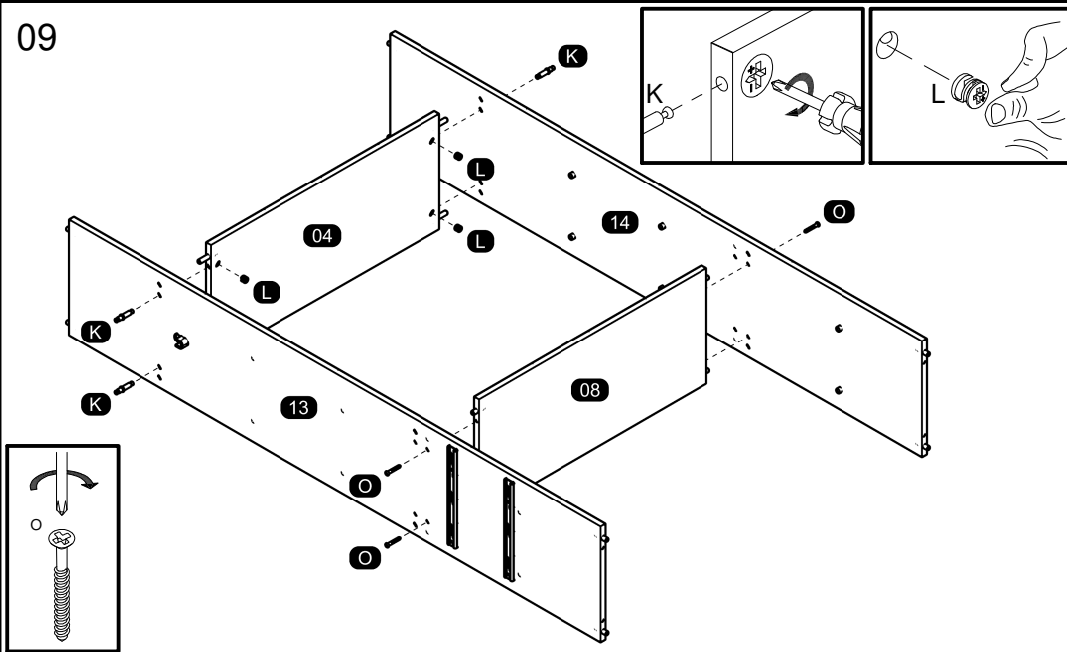

08

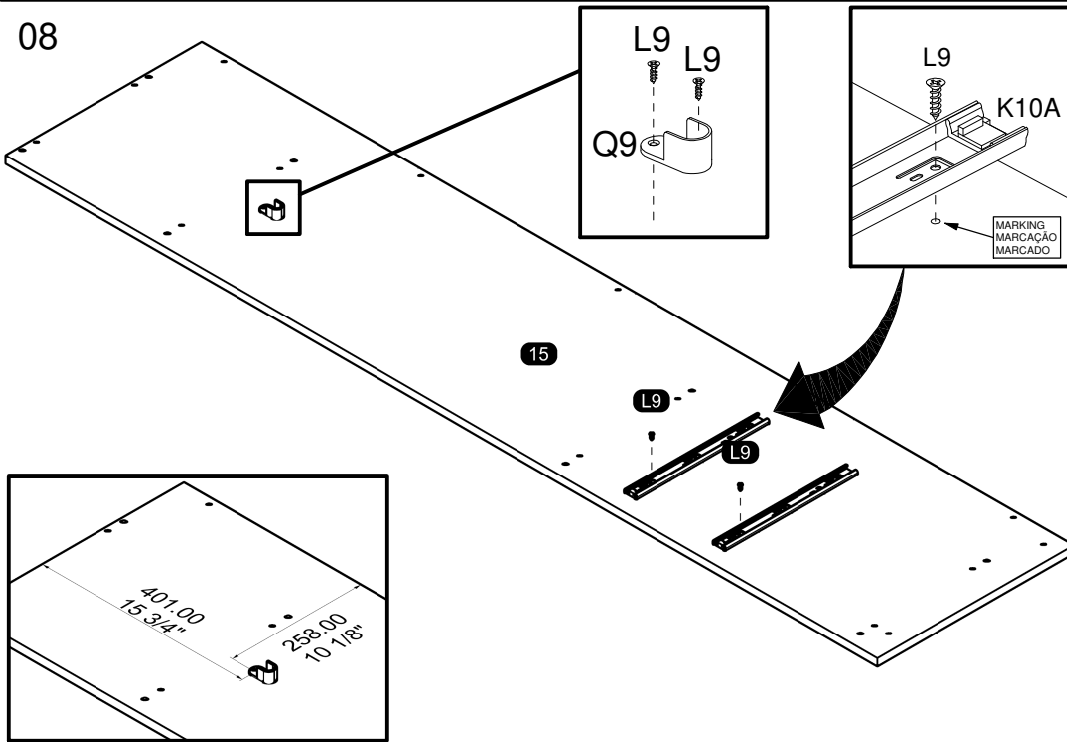

10

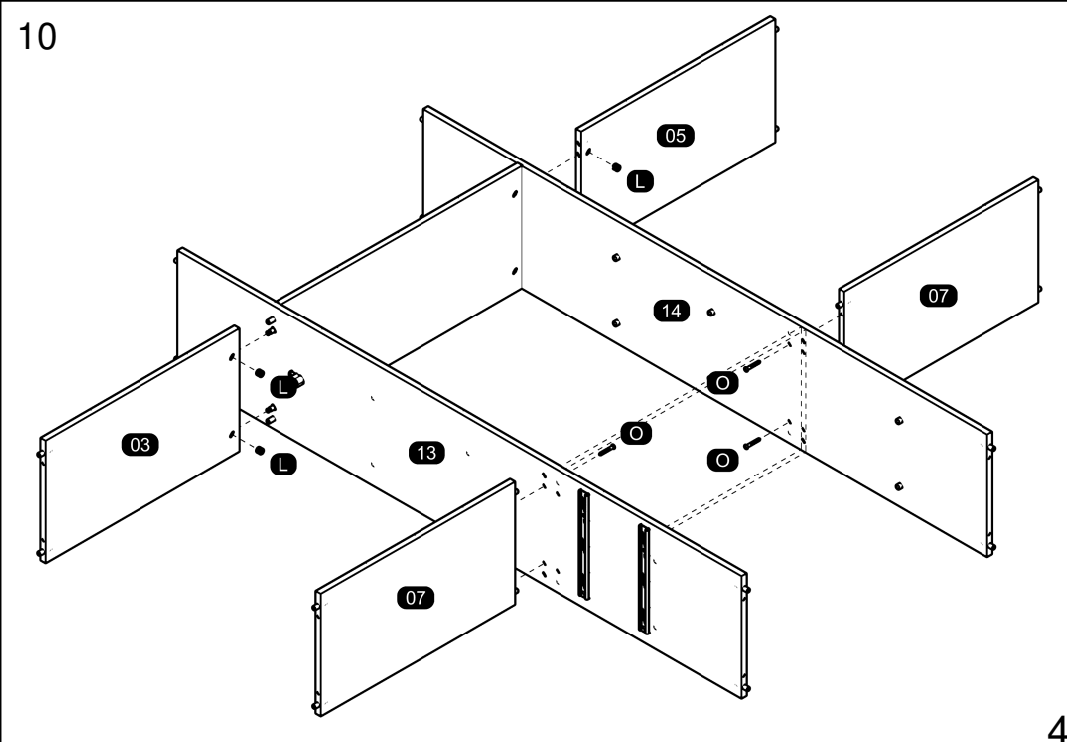

11

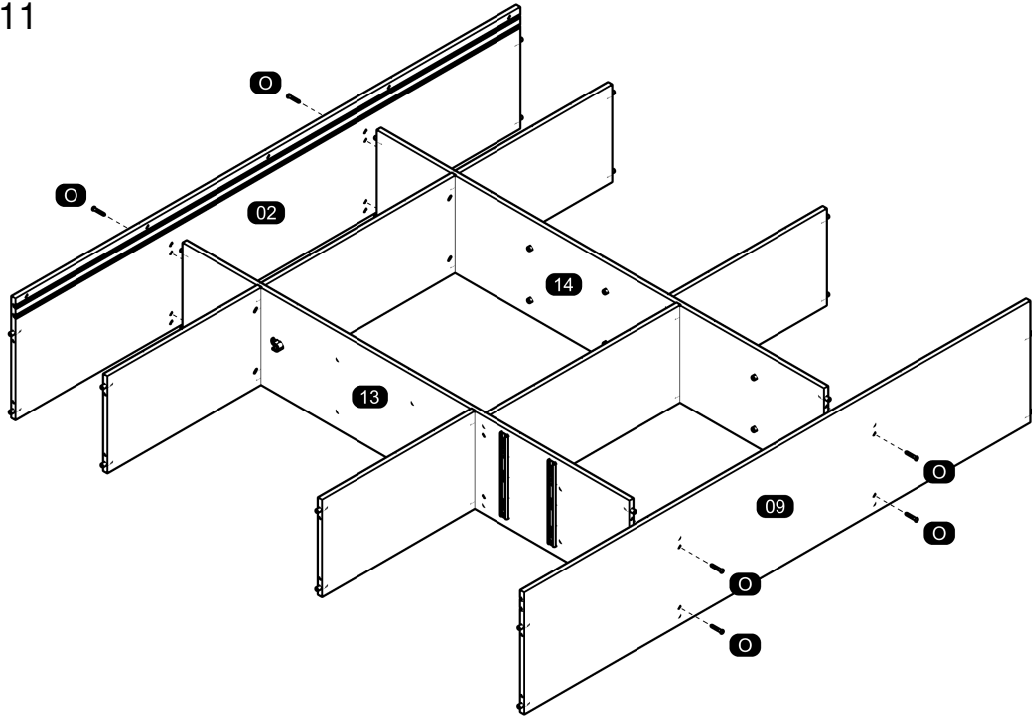

13

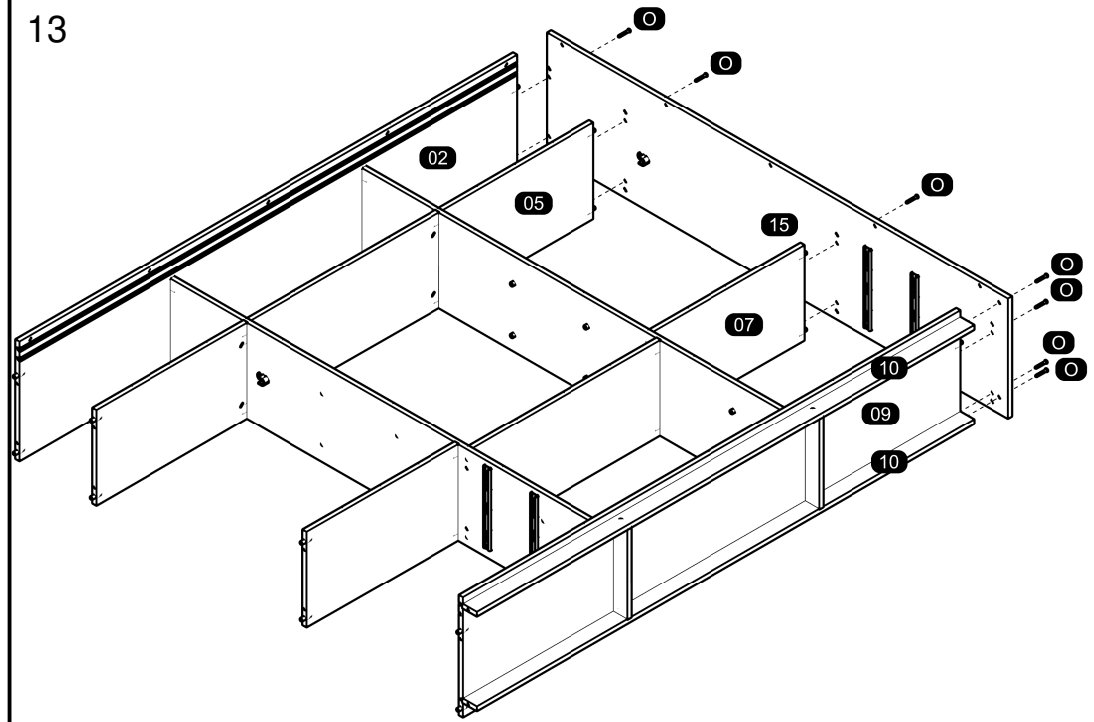

12

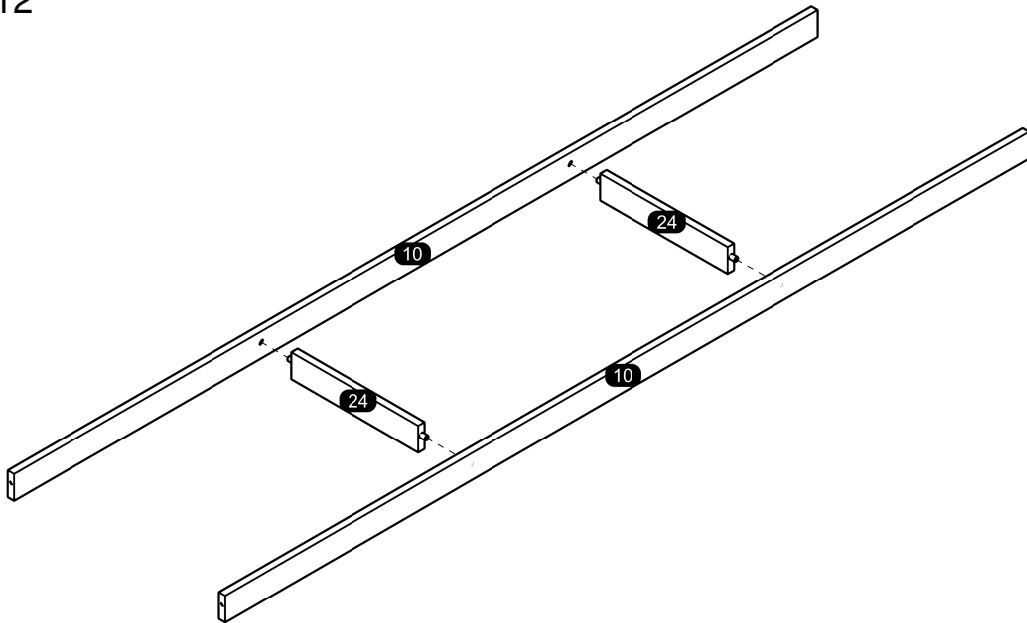

14

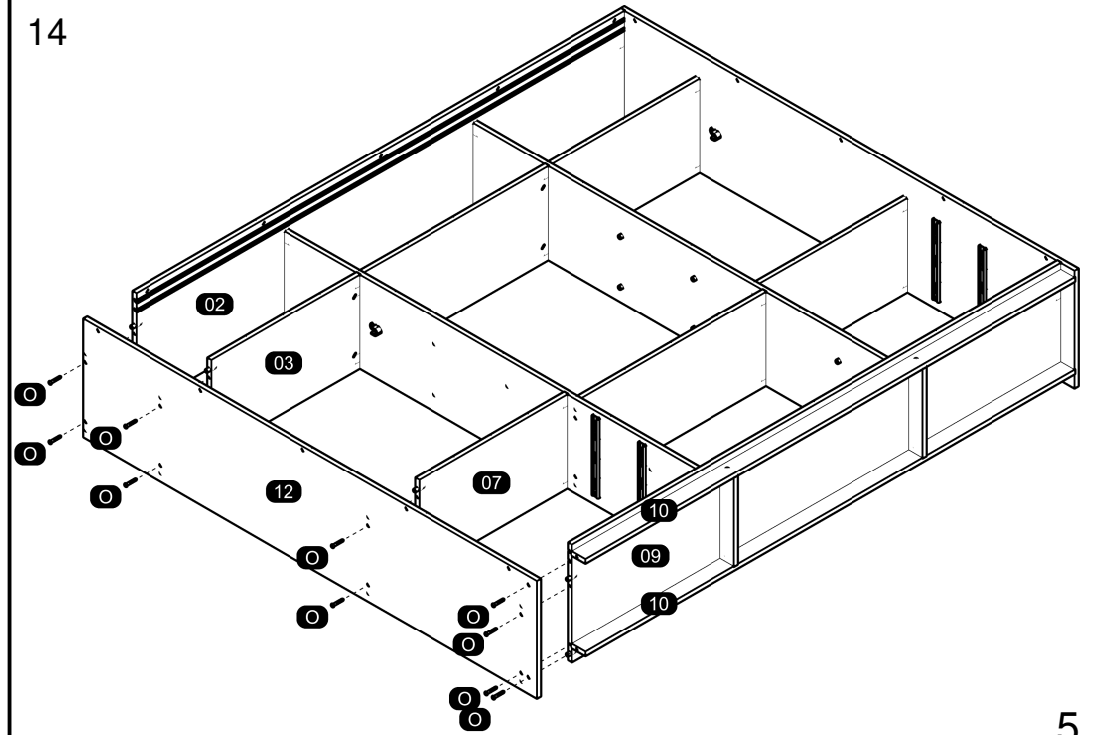

15

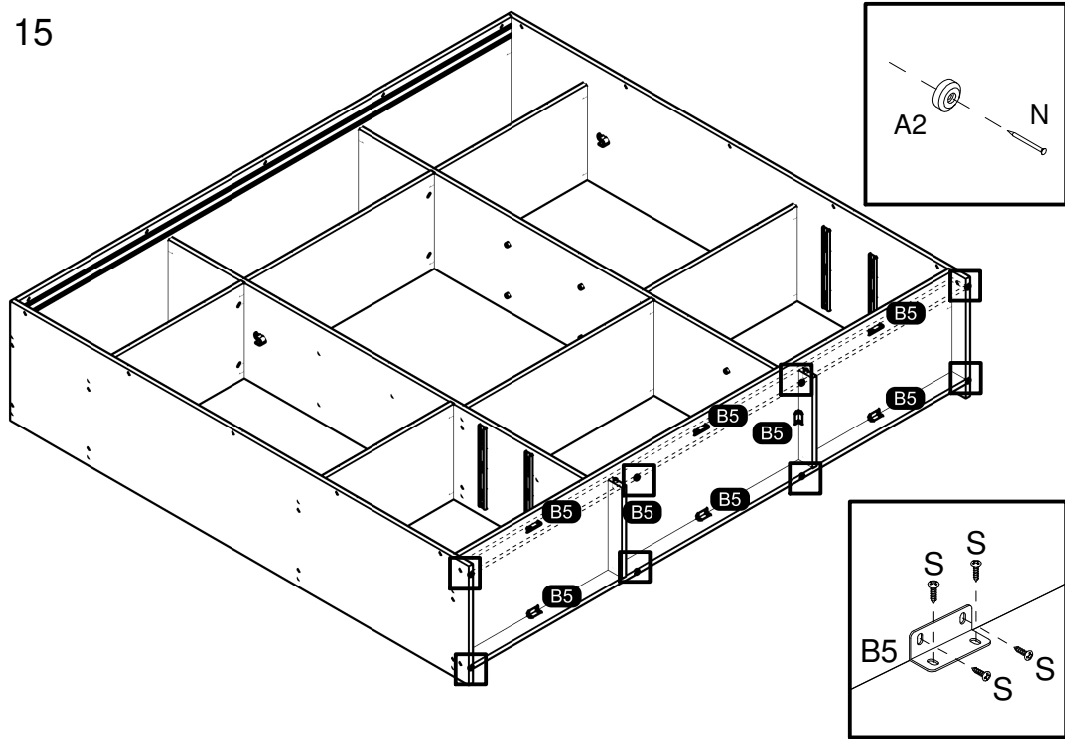

17

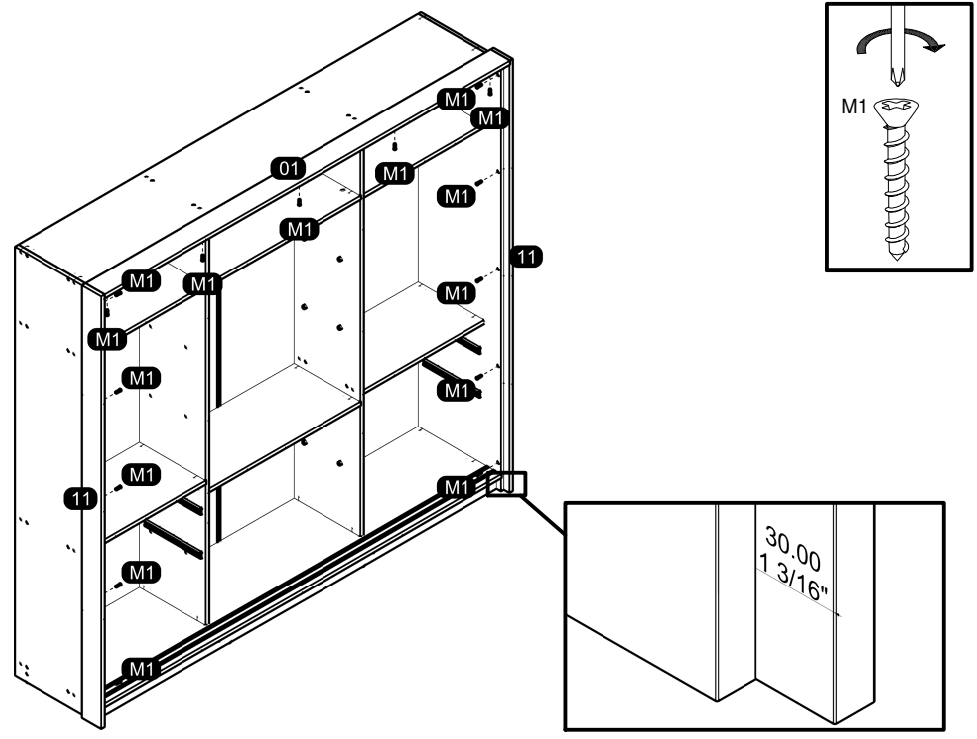

16

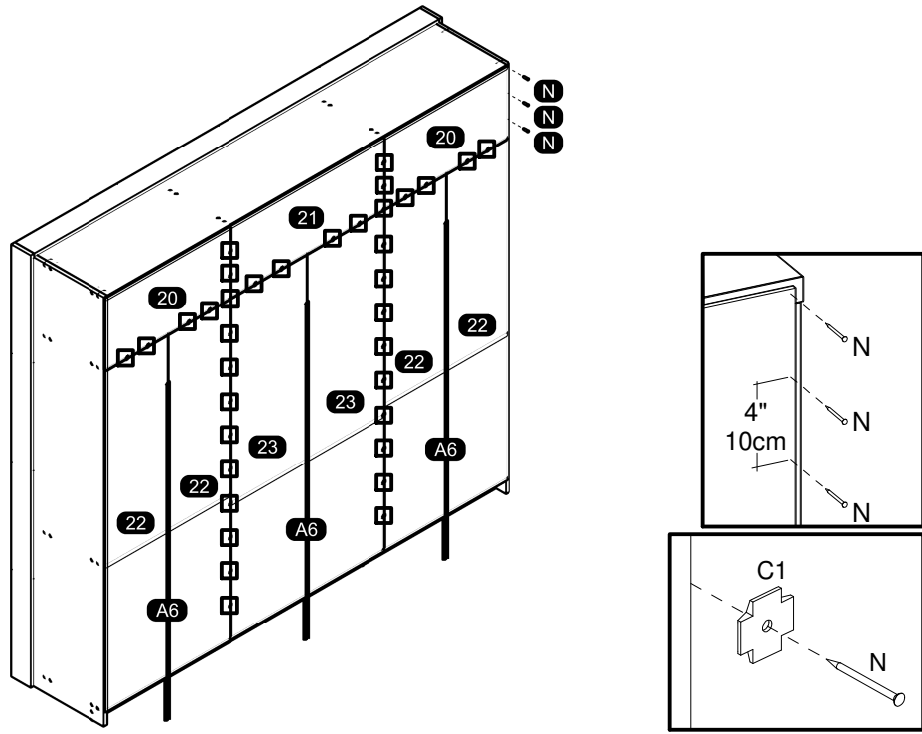

18

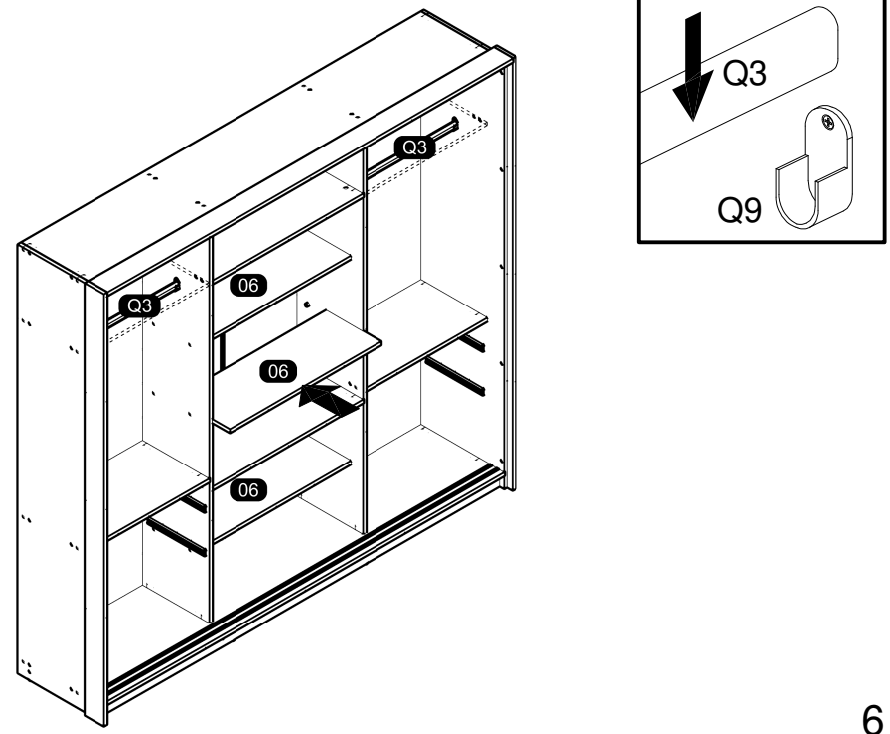

19

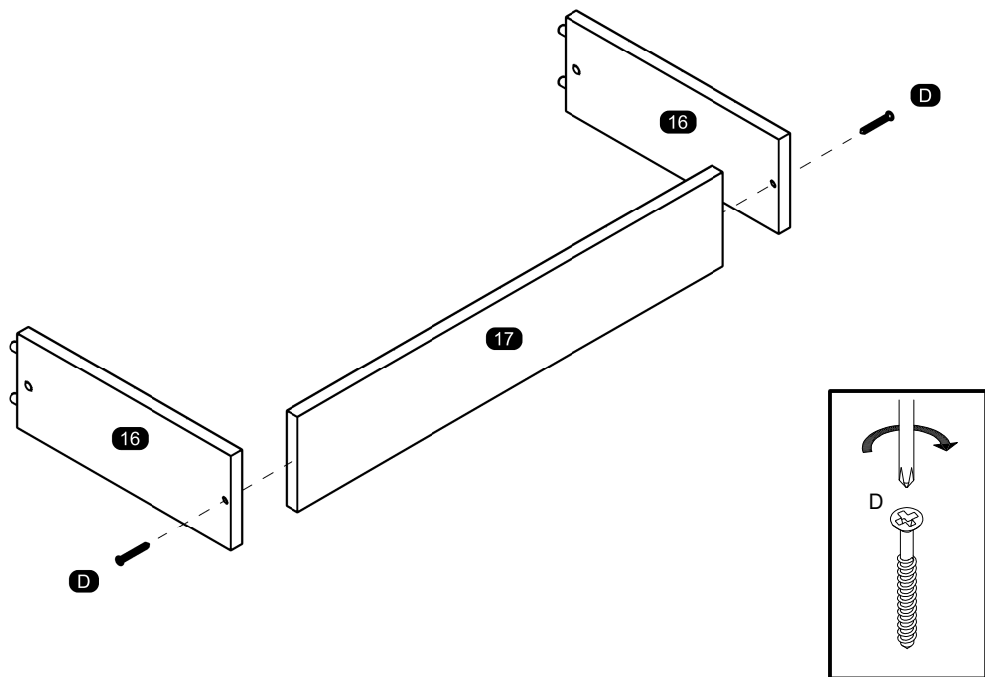

21

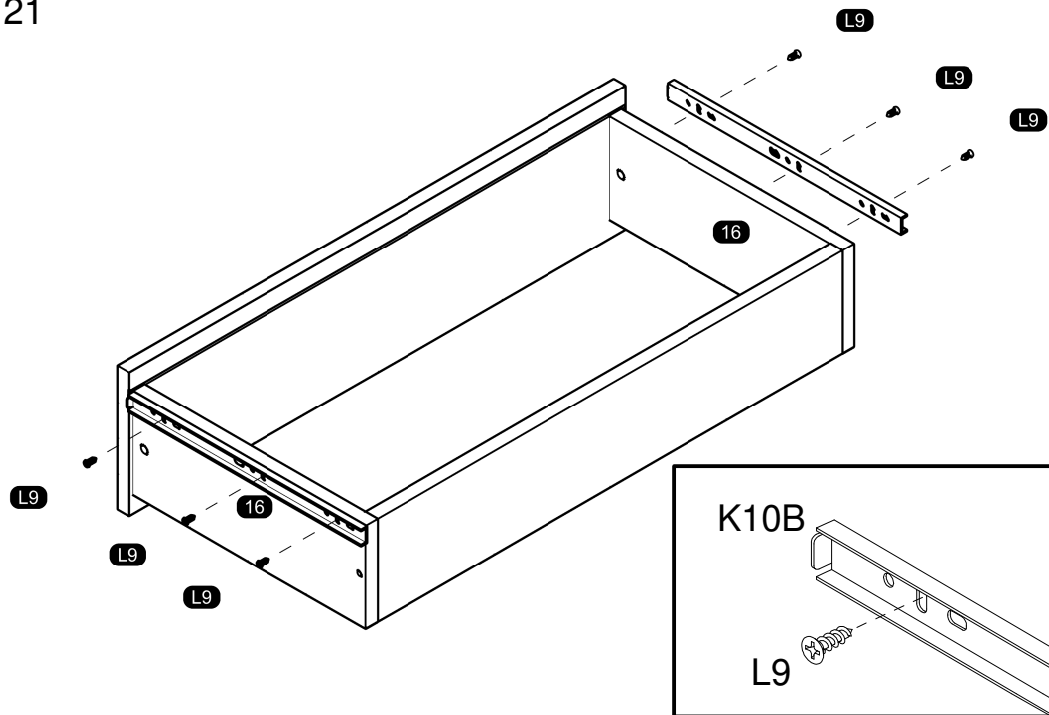

20

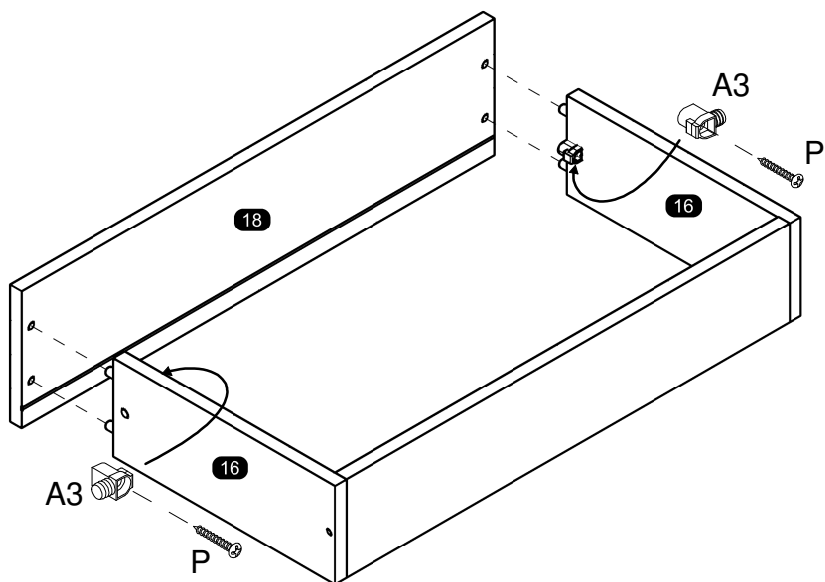

22

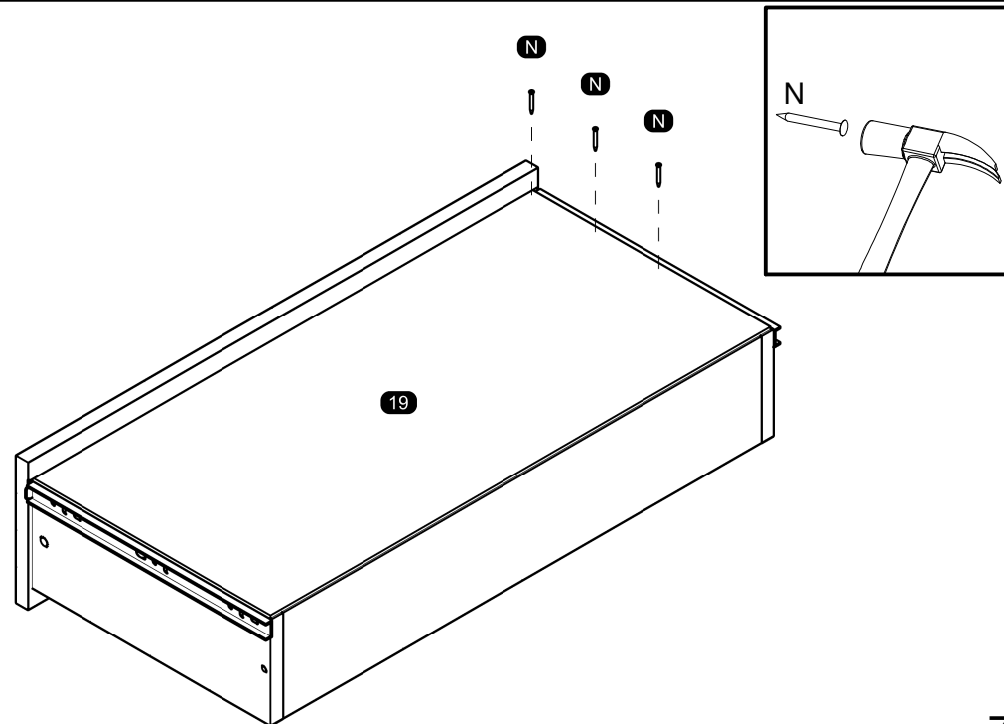

23

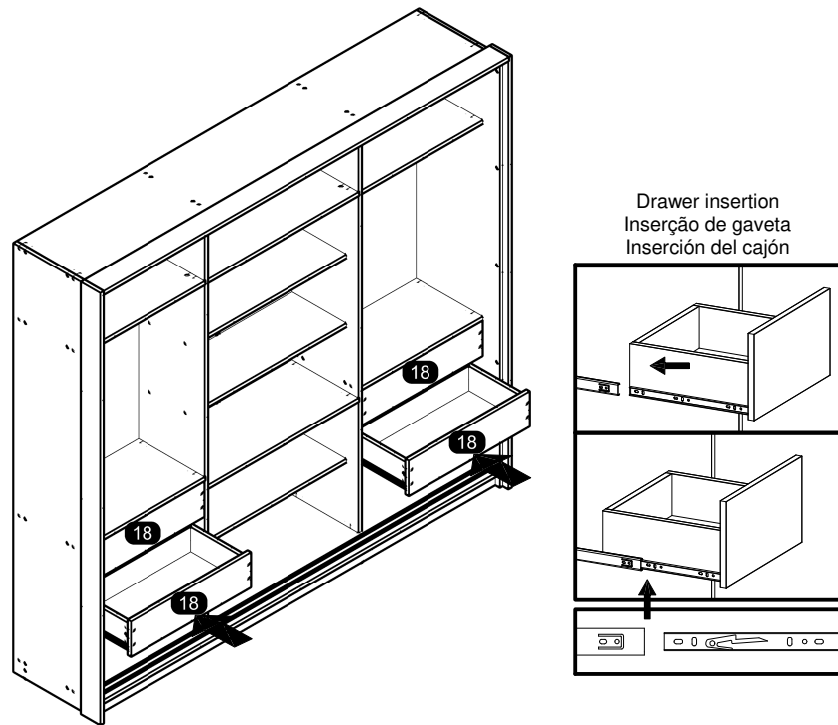

25

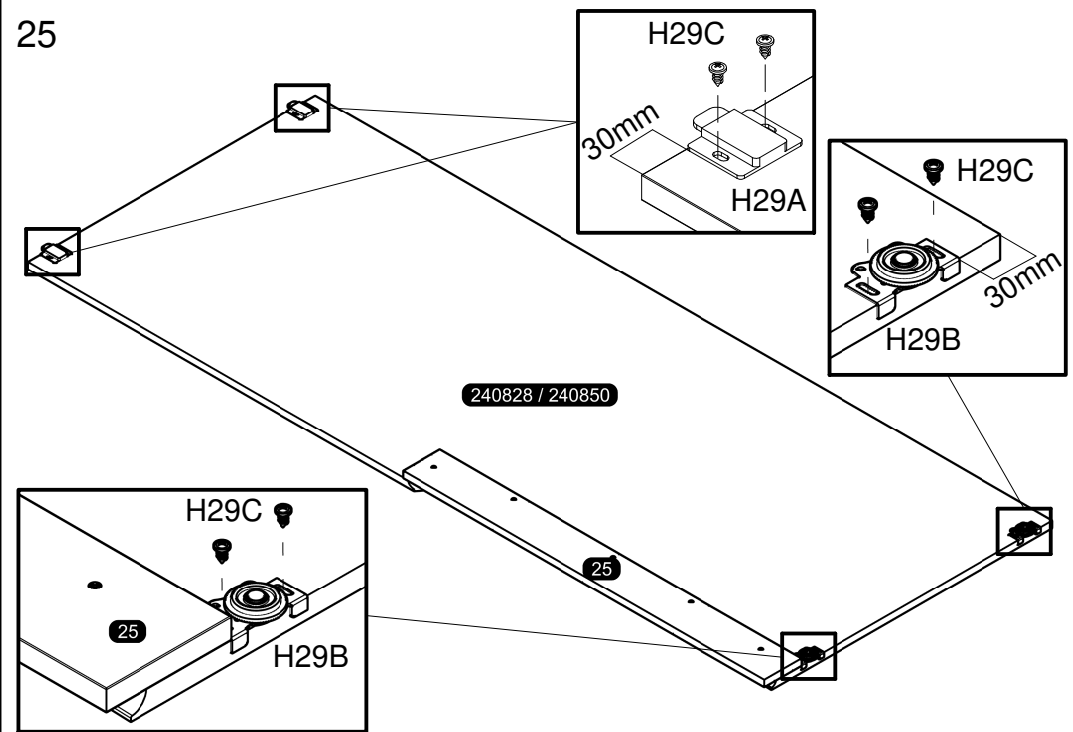

ASSEMBLY OF THE PORTO MODEL DOOR
MONTAGEM DA PORTA MODELO PORTO / MONTAJE DE LA PUERTA MODELO PORTO

MOUNTING ON THE CHOSEN DOOR MODEL
MONTAGEM NO MODELO DE PORTA ESCOLHIDO / MONTAJE EN EL MODELO DE PUERTA ELEGIDO

24

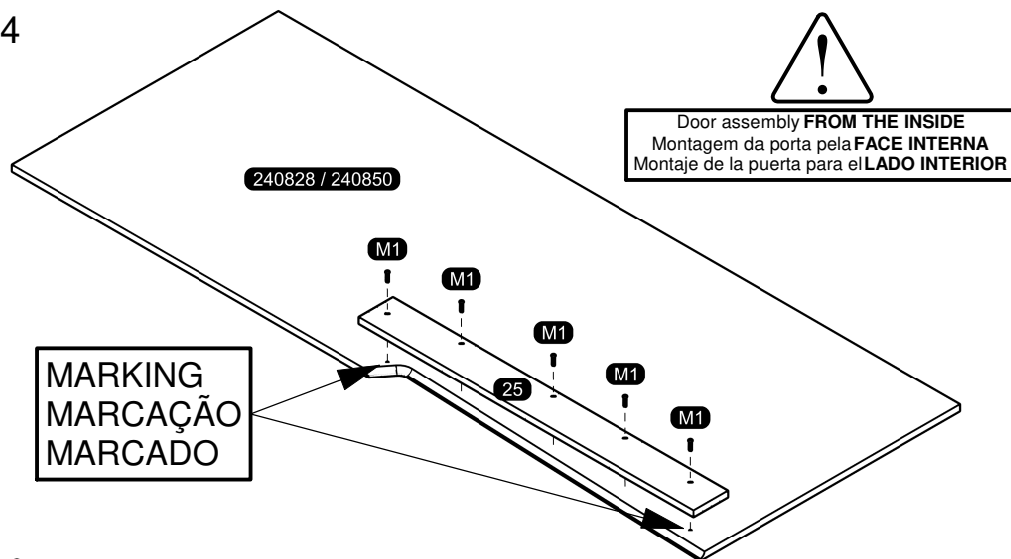

26

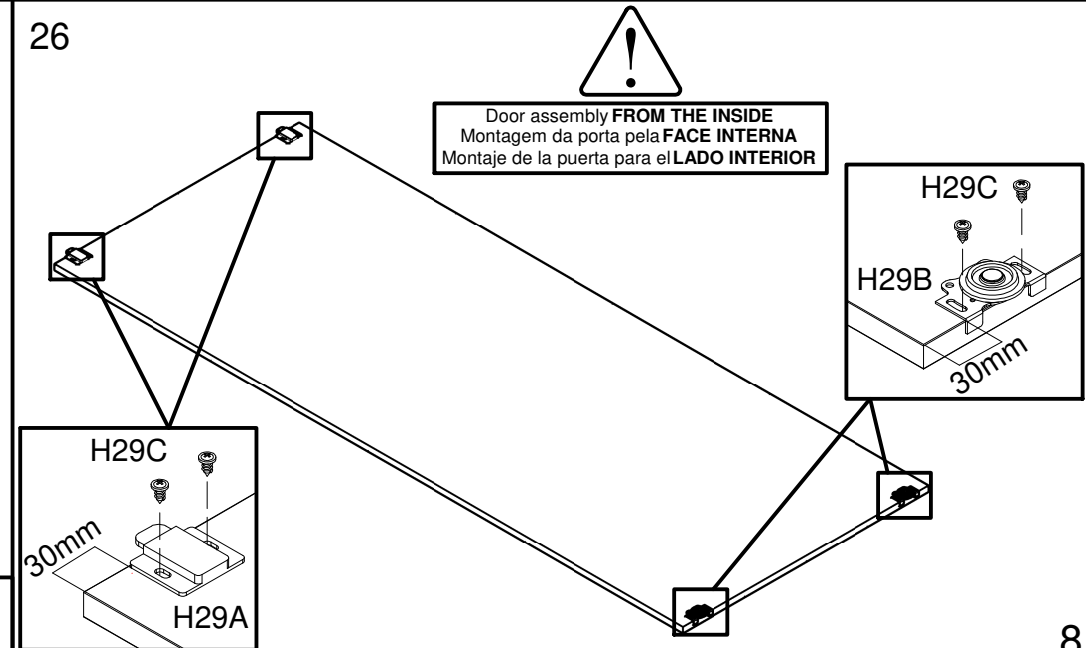

PARTS 25 SHOULD ONLY BE USED IF THE SELECTED DOOR MODEL IS PORTO.
AS PEÇAS 25 SERÃO APLICADAS APENAS NO CASO DE A PORTA ESCOLHIDA SER DO MODELO PORTO.
LAS PIEZAS 25 SOLO SE APLICARÁN EN CASO DE QUE LA PUERTA ELEGIDA SEA DEL MODELO PORTO.

27

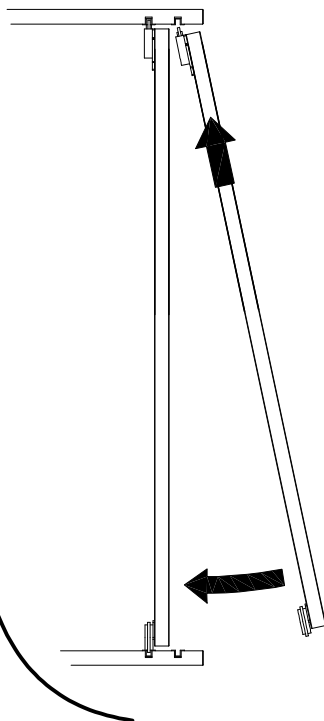
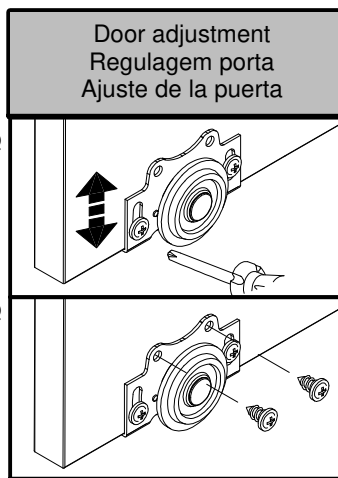
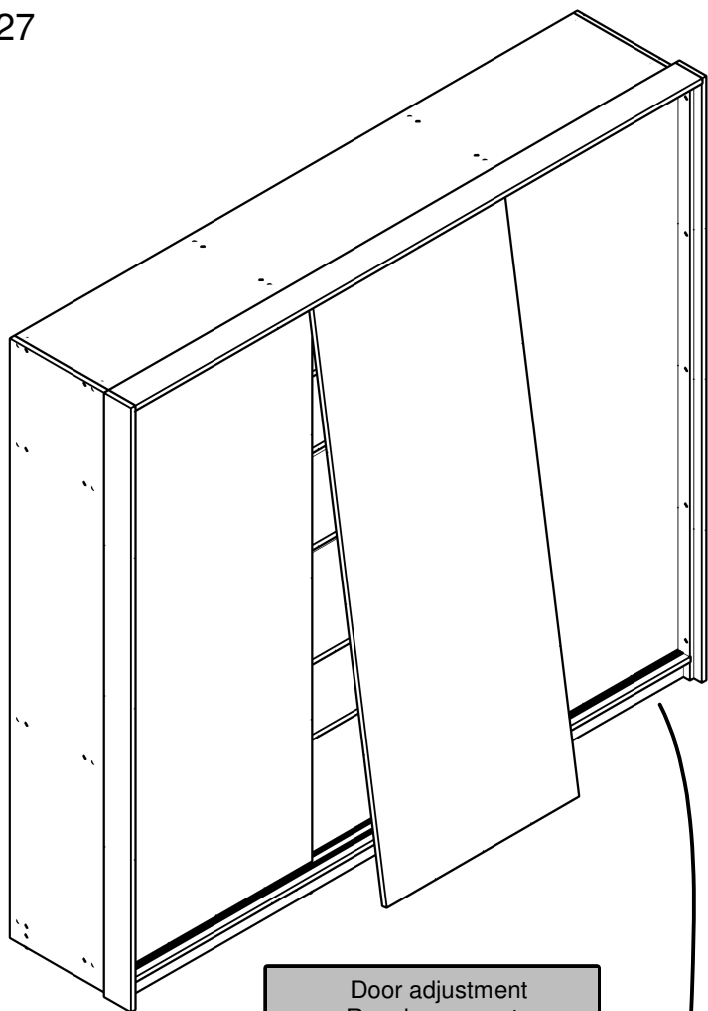

28

At the end of the assembly, insert the screw cover / hole plugs in the apparent holes.
Ao final da montagem, insira a(s) tampa(s) de parafuso / tapa furos nos furos que ficarem aparentes.
Al final del conjunto, coloque la tapa tornillo / tapón plástico en los agujeros que se hagan evidentes.

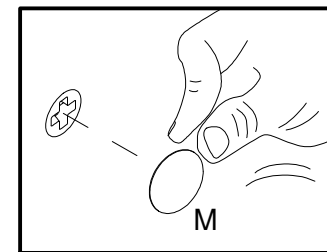
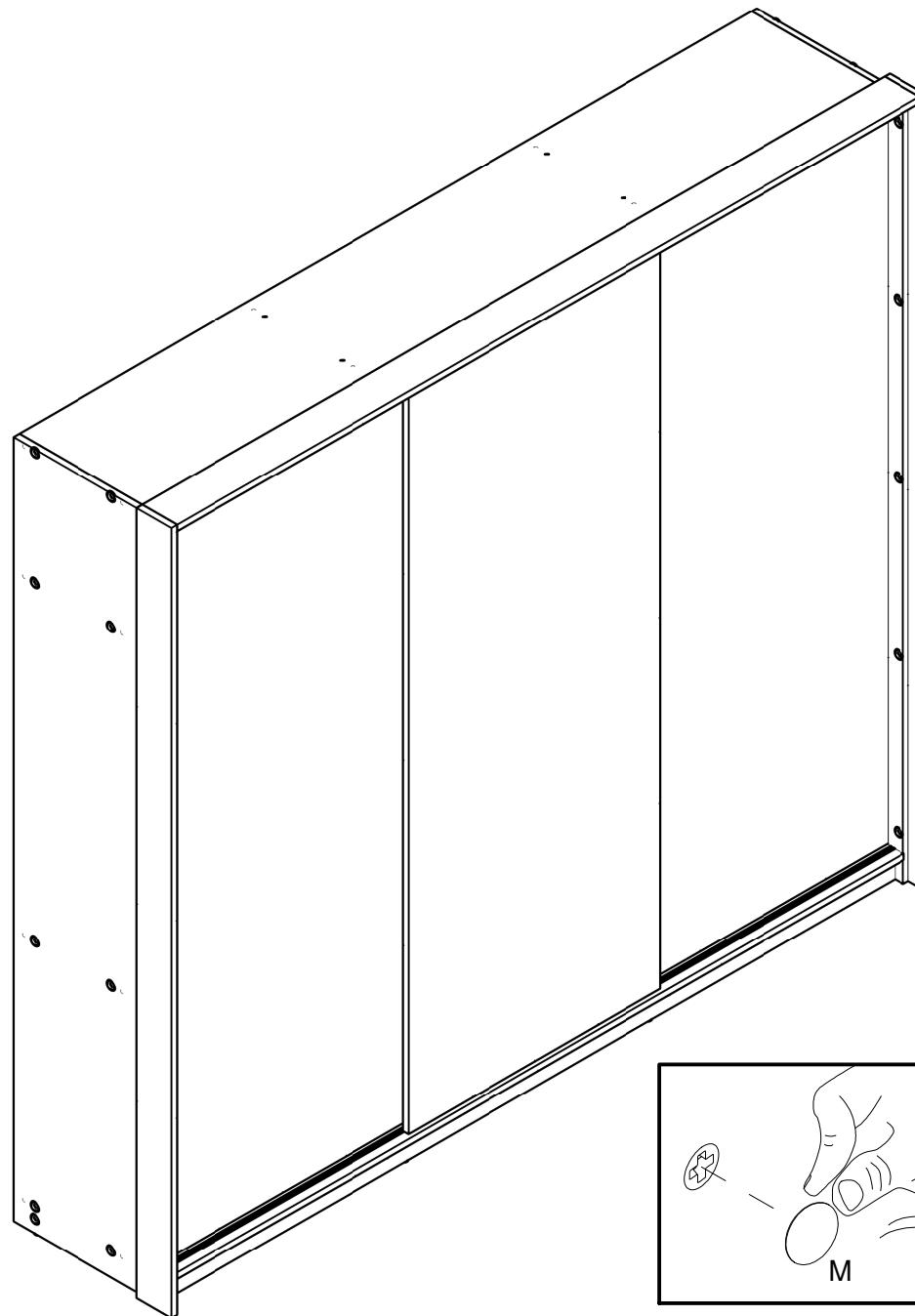

ASSEMBLY INSTRUCTIONS MANUAL DE MONTAGEM / INSTRUCCIONES DE ARMADO

LISBOA DOORS WARDROBE 3 SLIDING DOORS 4 DRAWERS
 PORTAS LISBOA ROUPEIRO 3PC 4G
 PUERTAS LISBOA ROPERO 3 PUERTAS CORREDERAS 4 CAJONES

Reference
Referência
Referencia

Revise
Revisão
Revisión **00**

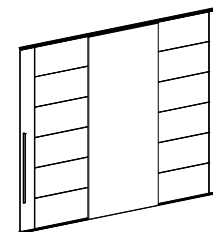

**YOU WILL NEED
VOCÊ VAI PRECISAR DE / USTED NECESITARÁ**

Tools not supplied
Ferramentas não fornecidas / Herramientas no incluidas

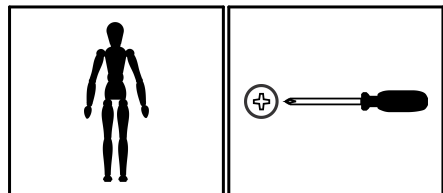

1 Person
1 Pessoa
1 Persona

Screwdriver Phillips
Chave Phillips
Destornillador cruz

**PARTS IDENTIFICATION
IDENTIFICAÇÃO DAS PEÇAS / IDENTIFICACIÓN DE LAS PIEZAS**

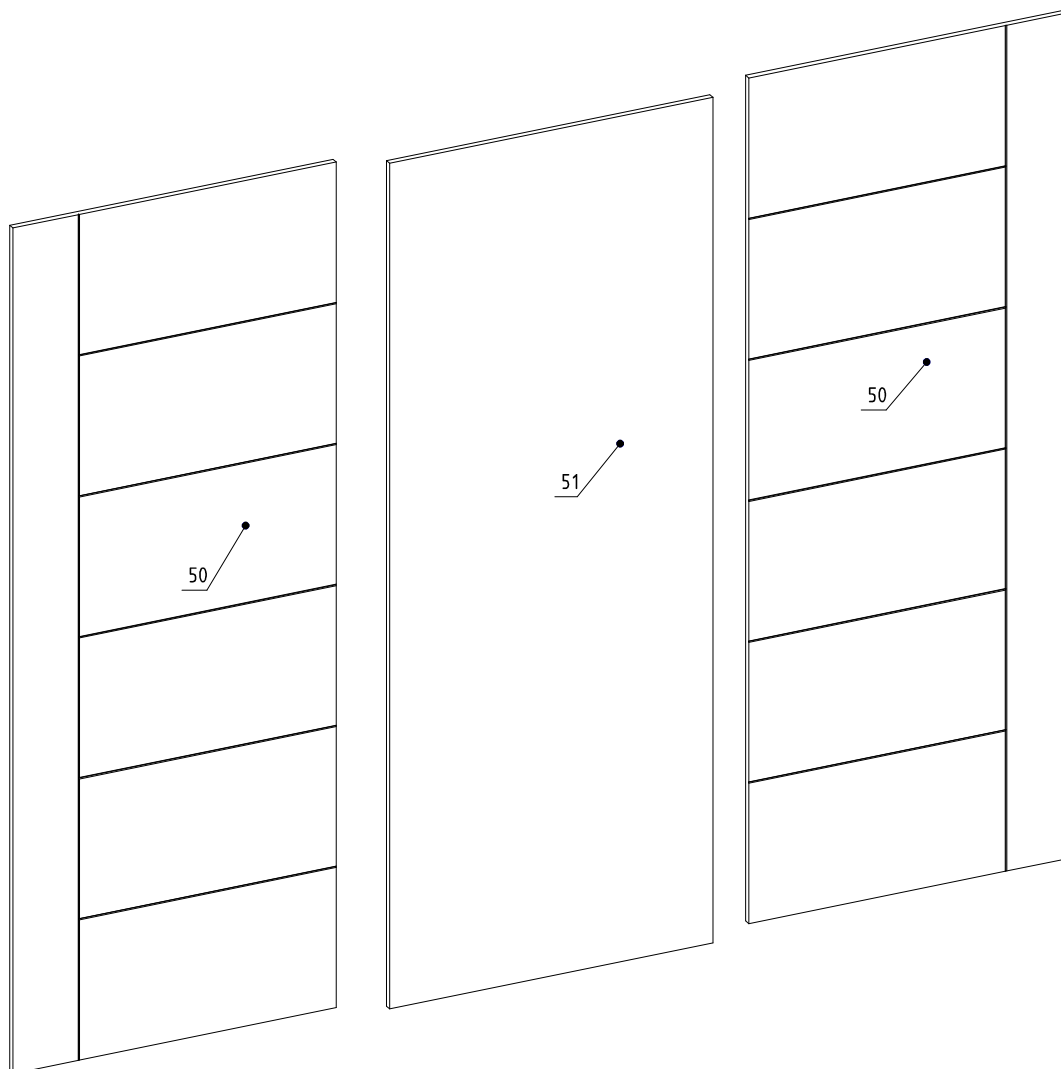

Nº	Measures_Inches	Medidas_cm	Qty./Qtd.
50	74 1/4 x 28 7/8 x 5/8	188.5 x 73.5 x 1.5	2
51	74 1/4 x 28 7/8 x 5/8	188.5 x 73.5 x 1.5	1



MAXIMUM RECOMMENDED WEIGHT
BEING THIS EVENLY DISTRIBUTED.

PESO MÁXIMO RECOMENDADO SENDO
ESTE DISTRIBUÍDO UNIFORMEMENTE.

PESO MÁXIMO RECOMENDADO SIENDO
ESTE UNIFORMEMENTE DISTRIBUIDO.

-	LB	KG
---	----	----

IDENTIFICATION OF ACCESSORIES IDENTIFICAÇÃO DOS ACESSÓRIOS/ IDENTIFICACIÓN DE ACCESORIOS



The separation of the accessories before you start the assembly will facilitate the same. In case of doubt on the size of the screws and bolts, use the ruler to bottom of page.
 A separação dos acessórios antes de iniciar a montagem facilitará a mesma. Em caso de dúvida no tamanho dos parafusos e cavilhas, utilize a régua ao final da página.
 La separación de los accesorios antes de comenzar el armado facilitará el mismo. En caso de duda sobre el tamaño de los tornillos y taquetes, utilice la regla al pie de página.

M1		Flat head screw Parafuso chato / Tornillo de cabeza plana	3,5x25 mm	8
K28		Handle Puxador T Menor / Tirador	715 x 20 mm	2



ASSEMBLY MONTAGEM / ARMADO

01

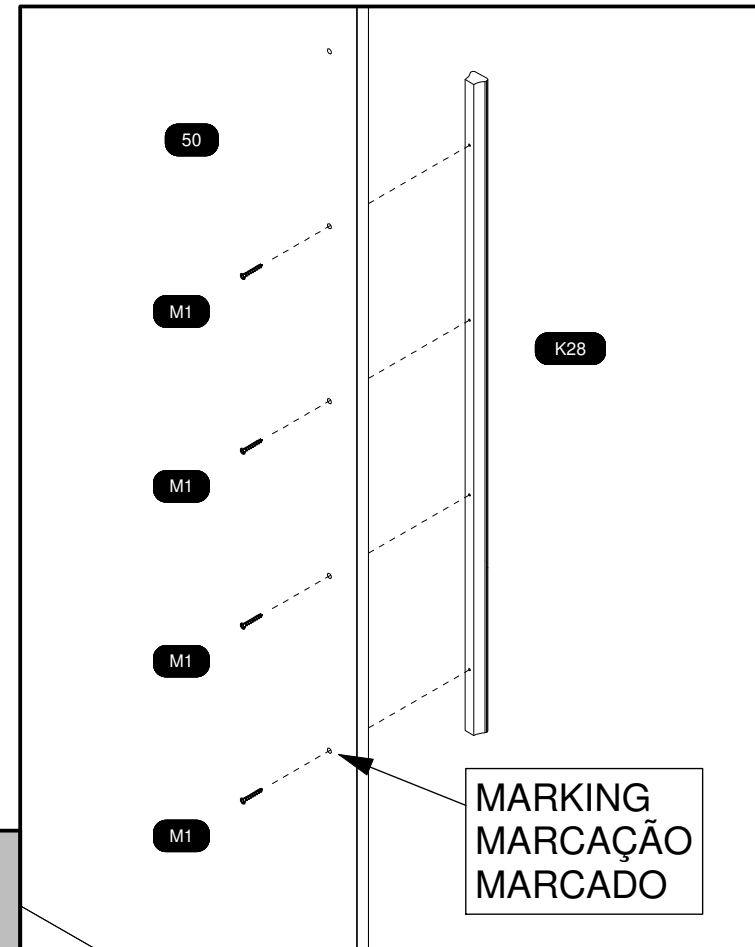
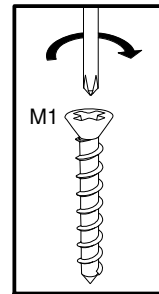
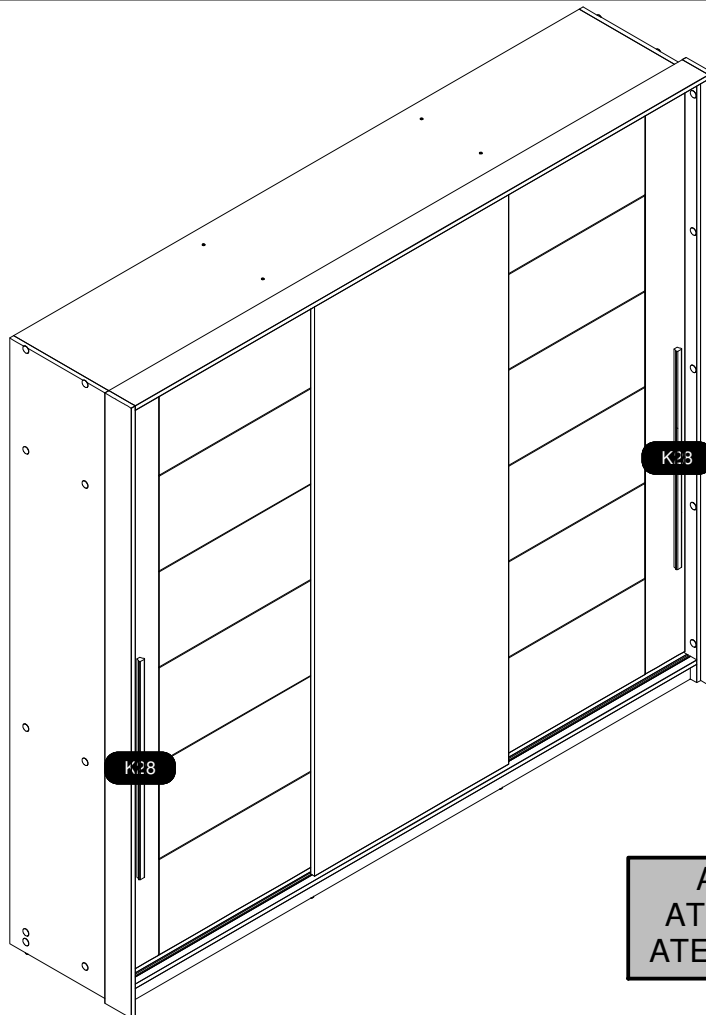

ATTENTION for the hole position.
 ATENÇÃO para a posição da furação.
 ATENCIÓN para la posición del agujero.

ASSEMBLY INSTRUCTIONS
MANUAL DE MONTAGEM / INSTRUCCIONES DE ARMADO

MIRRORS
ESPELHOS
ESPEJOS

Reference
Referência
Referencia

Revise
Revisão
Revision

APPLY DOUBLE-SIDED TAPE TO THE BACK OF THE MIRROR
APLICAR A FITA DUPLA FACE NO VERSO DO ESPELHO
APLICAR CINTA ADHESIVA DOBLE EN LO POSTERIOR DEL ESPEJO

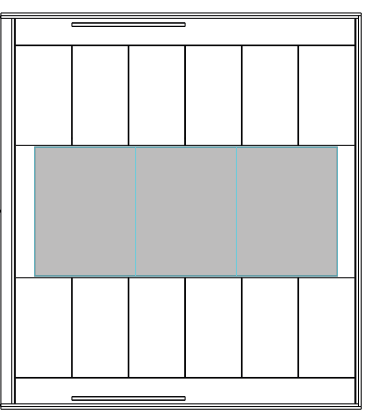
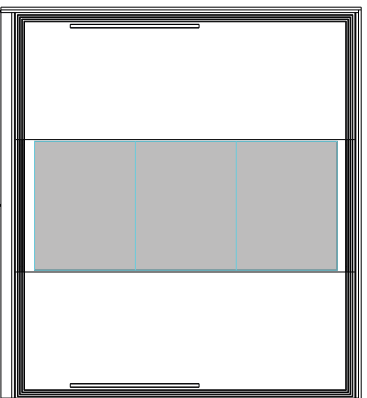
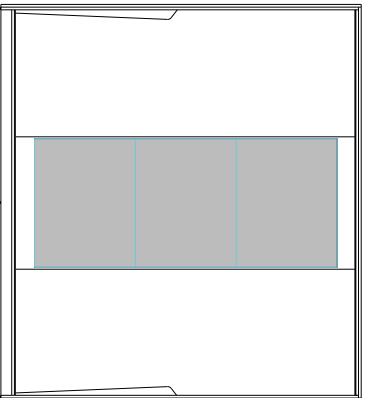
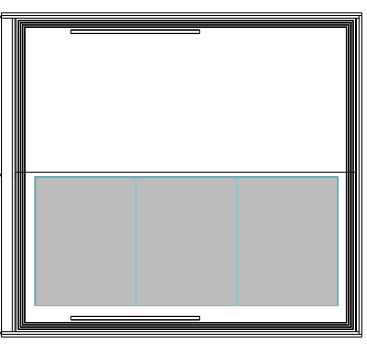
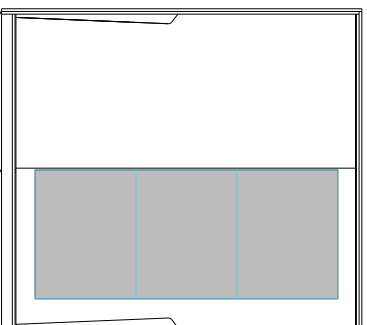
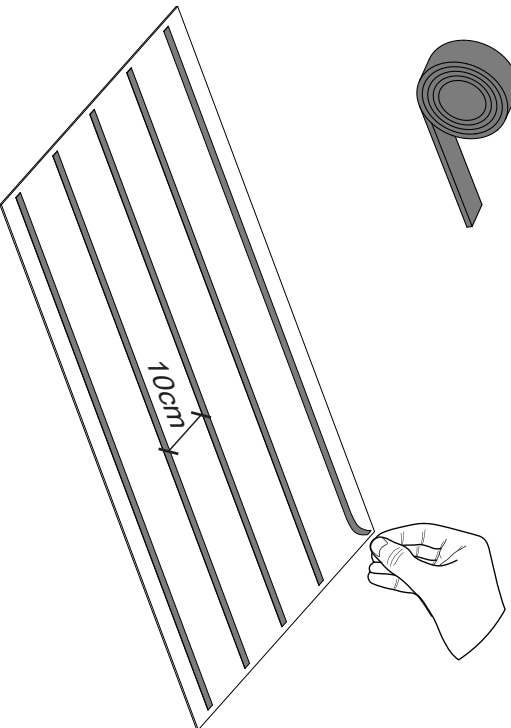
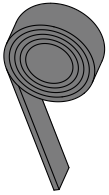

YOU WILL NEED / VOCÊ VAI PRECISAR DE / USTED NECESITARÁ

Tools not supplied / Ferramentas não fornecidas / H erramientas no incluidas

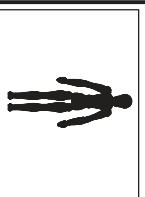

1 Person
1 Pessoa
1 Persona

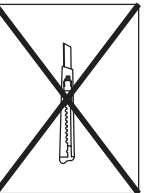

Stylus
Estilote
Estilote

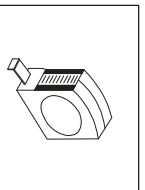

Measuring tape
Trena
Cinta de medición

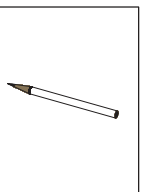

Pencil
Lápis
Lápiz