

ASSEMBLY INSTRUCTIONS MANUAL DE MONTAGEM / INSTRUCCIONES DE ARMADO

BARCELONA WARDOBRE FRONTS 4 - 6 DOORS
FRENTE ROUPEIRO BARCELONA 4 - 6 PORTAS
FRENTE ROUPEIRO BARCELONA 4 - 6 PUERTAS

Reference | Revise
Referência | Revisão
Referencia | Revisión

250646

00

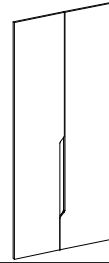

YOU WILL NEED
VOCÊ VAI PRECISAR DE / USTED NECESITARÁ

Tools not supplied
Ferramentas não fornecidas / Herramientas no incluidas



2 People
2 Pessoas
2 Personas

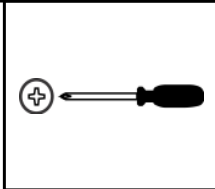

Screwdriver Phillips
Chave Phillips
Destornillador cruz

MAXIMUM RECOMMENDED WEIGHT BEING THIS EVENLY DISTRIBUTED.
PESO MÁXIMO RECOMENDADO SENDO ESTE DISTRIBUÍDO UNIFORMEMENTE.
PESO MÁXIMO RECOMENDADO SIENDO ESTE UNIFORMEMENTE DISTRIBUIDO.

—	LB	KG
---	----	----

PARTS IDENTIFICATION
IDENTIFICAÇÃO DAS PEÇAS / IDENTIFICACIÓN DE LAS PIEZAS

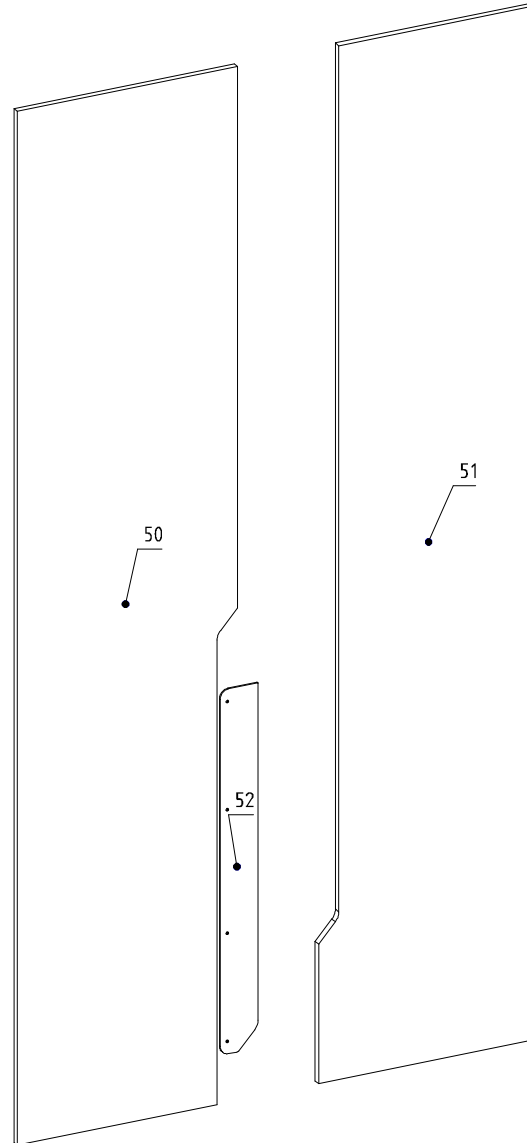

Nº	Measures_Inches	Medidas_cm	Qty./Qtd.
50	84 3/8 x 18 1/4 x 5/8	214.2 x 46.5 x 1.5	1
51	84 3/8 x 18 1/4 x 5/8	214.2 x 46.5 x 1.5	1
52	29 3/4 x 3 1/8 x 1/8	75.6 x 8.0 x 0.3	1

IDENTIFICATION OF ACCESSORIES IDENTIFICAÇÃO DOS ACESSÓRIOS/ IDENTIFICACIÓN DE ACCESORIOS



The separation of the accessories before you start the assembly will facilitate the same. In case of doubt on the size of the screws and bolts, use the ruler to bottom of page.
 A separação dos acessórios antes de iniciar a montagem facilitará a mesma. Em caso de dúvida no tamanho dos parafusos e cavilhas, utilize a régua ao final da página.
 La separación de los accesorios antes de comenzar el armado facilitará el mismo. En caso de duda sobre el tamaño de los tornillos y taquetes, utilice la regla al pie de página.

P5		Flat head screw Parafuso chato / Tornillo de cabeza plana	3,5x14 mm	4
----	--	--	-----------	---



ASSEMBLY MONTAGEM / ARMADO

01

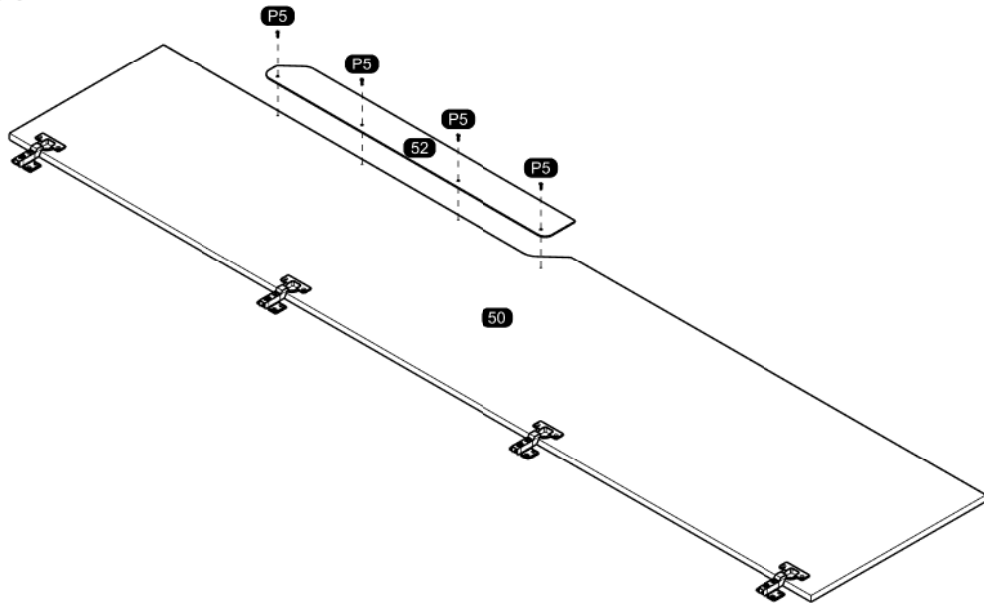

02

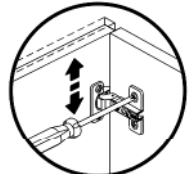
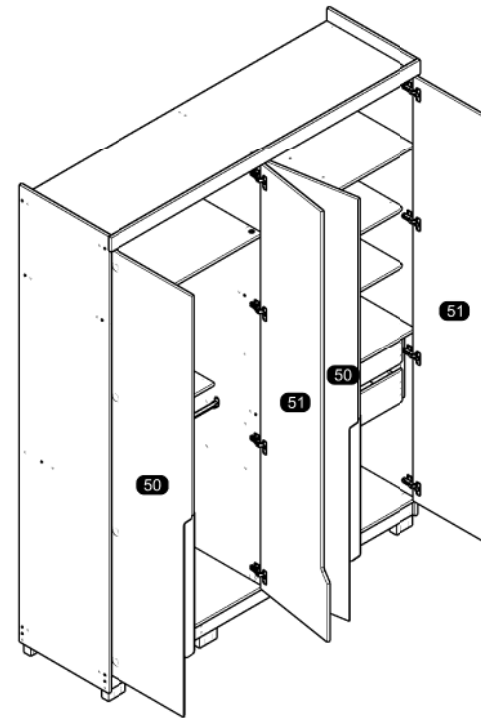

Vertical Adjustment
Regulagem Vertical
Ajuste Vertical

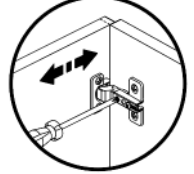

Horizontal Adjustment
Regulagem Horizontal
Ajuste Horizontal

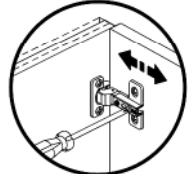

Depth Adjustment
Regulagem Profundidade
Ajuste Profundidad

03

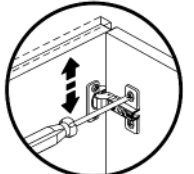
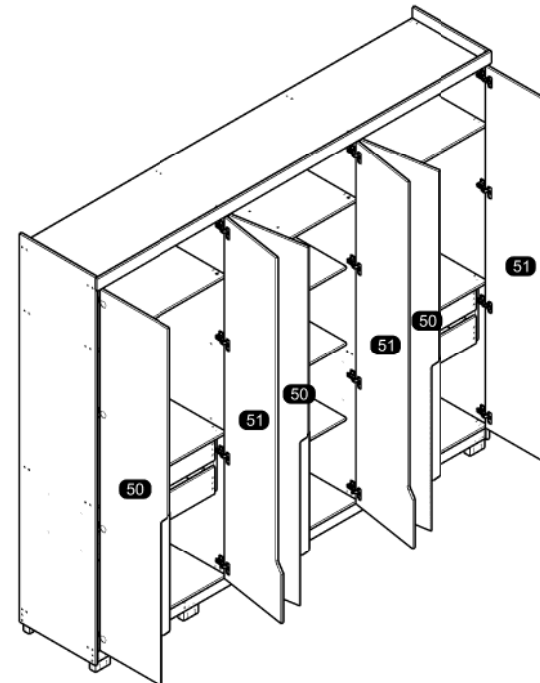

Vertical Adjustment
Regulagem Vertical
Ajuste Vertical

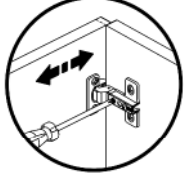

Horizontal Adjustment
Regulagem Horizontal
Ajuste Horizontal

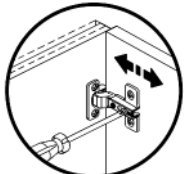

Depth Adjustment
Regulagem Profundidade
Ajuste Profundidad

ASSEMBLY INSTRUCTIONS MANUAL DE MONTAGEM / INSTRUCCIONES DE ARMADO

WARDROBE 6 DOORS
ROUPEIRO 6 PORTAS
ROPERO 6 PUERTAS

Reference
Referência
Referencia **240937** | Revise
| Revisão
| Revisión **00**

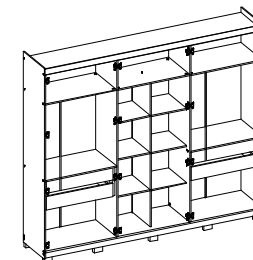

YOU WILL NEED VOCÊ VAI PRECISAR DE / USTED NECESITARÁ

Tools not supplied
Ferramentas não fornecidas / Herramientas no incluidas

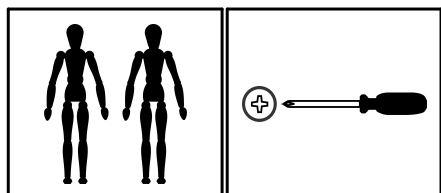

2 People
2 Pessoas
2 Personas

Screwdriver Phillips
Chave Phillips
Destornillador cruz

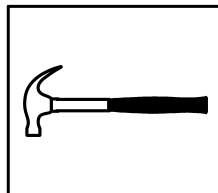

Hammer
Martelo
Martillo

PARTS IDENTIFICATION IDENTIFICAÇÃO DAS PEÇAS / IDENTIFICACIÓN DE LAS PIEZAS

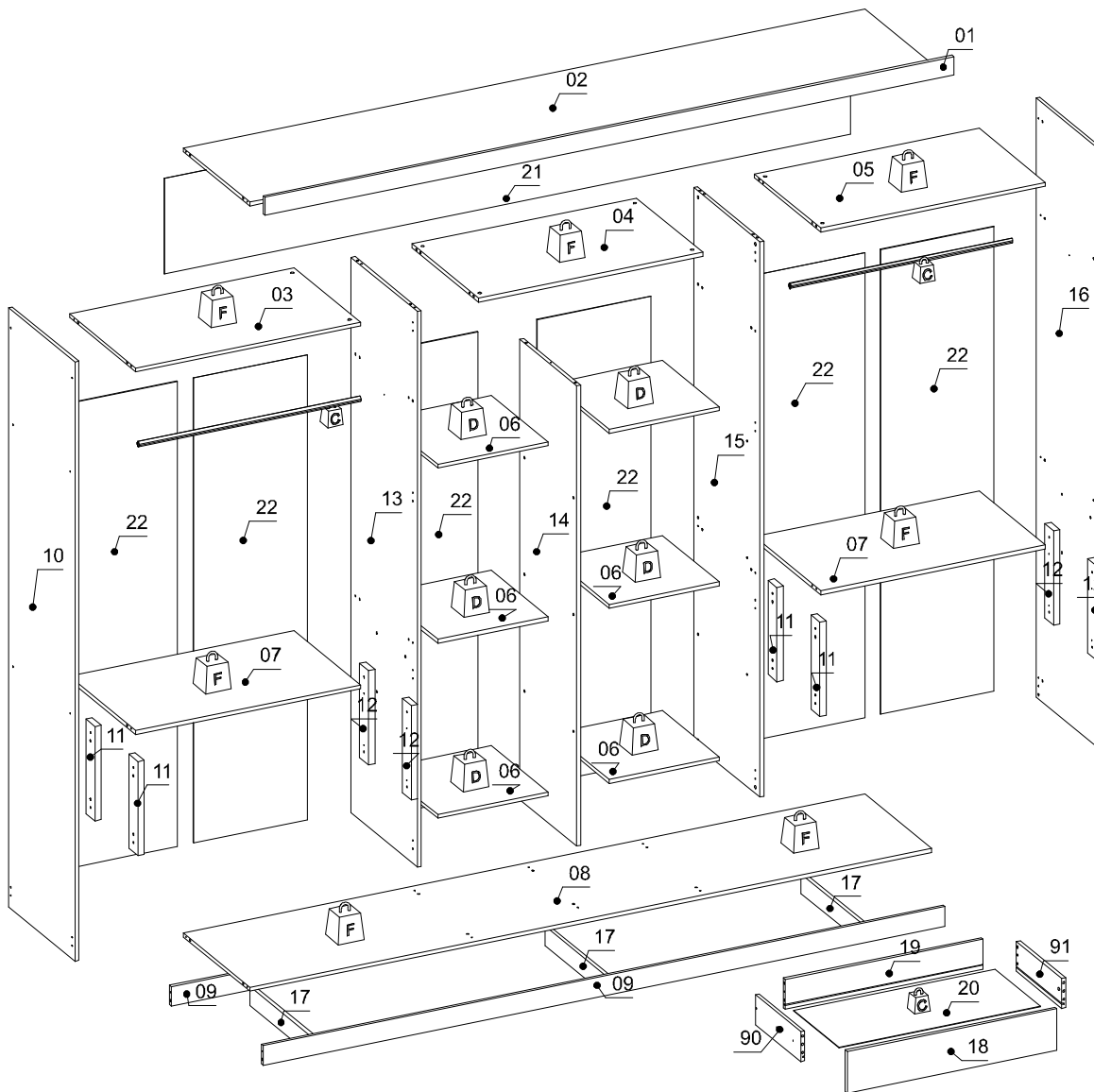

Nº	Measures_Inches	Medidas_cm	Qty./Qtd.
01	106 1/8 x 2 3/4 x 5/8	269.7 x 7.0 x 1.5	1
02	105 x 20 1/2 x 5/8	266.7 x 52.0 x 1.5	1
03	34 5/8 x 20 1/2 x 5/8	87.9 x 52.0 x 1.5	1
04	34 5/8 x 20 1/2 x 5/8	87.9 x 52.0 x 1.5	1
05	34 5/8 x 20 1/2 x 5/8	87.9 x 52.0 x 1.5	1
06	17 x 17 1/2 x 5/8	43.2 x 44.5 x 1.5	6
07	34 5/8 x 20 1/2 x 5/8	87.9 x 52.0 x 1.5	2
08	105 x 20 1/2 x 5/8	266.7 x 52.0 x 1.5	1
09	105 x 3 x 5/8	266.7 x 7.5 x 1.5	2
10	90 1/2 x 20 1/2 x 5/8	230.0 x 52.0 x 1.5	1
11	14 1/4 x 2 3/4 x 1	36.2 x 7.0 x 2.5	4
12	14 1/4 x 2 3/4 x 1	36.2 x 7.0 x 2.5	4
13	83 7/8 x 20 1/2 x 5/8	213.2 x 52.0 x 1.5	1
14	69 5/8 x 17 1/2 x 5/8	176.7 x 44.5 x 1.5	1
15	83 7/8 x 20 1/2 x 5/8	213.2 x 52.0 x 1.5	1
16	90 1/2 x 20 1/2 x 5/8	230.0 x 52.0 x 1.5	1
17	18 1/4 x 3 x 5/8	46.5 x 7.5 x 1.5	3
18	32 3/8 x 6 1/4 x 5/8	82.1 x 16.0 x 1.5	4
19	30 1/2 x 4 1/2 x 5/8	77.4 x 11.5 x 1.5	4
20	31 x 13 7/8 x 1/8	78.8 x 35.4 x 0.3	4
21	105 3/4 x 14 1/2 x 1/8	268.7 x 36.7 x 0.3	1
22	70 1/4 x 17 1/2 x 1/8	178.4 x 44.4 x 0.3	6
90	14 x 4 1/2 x 5/8	35.5 x 11.5 x 1.5	4
91	14 x 4 1/2 x 5/8	35.5 x 11.5 x 1.5	4

 MAXIMUM RECOMMENDED WEIGHT BEING THIS EVENLY DISTRIBUTED.
PESO MÁXIMO RECOMENDADO SENDO ESTE DISTRIBUIDO UNIFORMEMENTE.
PESO MÁXIMO RECOMENDADO SIENDO ESTE UNIFORMEMENTE DISTRIBUIDO.

	LB	KG
—		
C	6	3
D	11	5
F	22	10

IDENTIFICATION OF ACCESSORIES

IDENTIFICAÇÃO DOS ACESSÓRIOS/ IDENTIFICACIÓN DE ACCESORIOS



The separation of the accessories before you start the assembly will facilitate the same. In case of doubt on the size of the screws and bolts, use the ruler to bottom of page.

A separação dos acessórios antes de iniciar a montagem facilitará a mesma. Em caso de dúvida no tamanho dos parafusos e cavilhas, utilize a régua ao final da página.

La separación de los accesorios antes de comenzar el armado facilitará el mismo. En caso de duda sobre el tamaño de los tornillos y taquetes, utilice la regla al pie de página.

A1		Glue Cola / Pegamento	13 g	1
A4		Metalic bracket Cantoneira de metal / Suporte de metal	22x22 mm	3
A6		"H" profile Perfil "H" / Perfil "H"	-	3
B5		Metalic angle plates Cantoneira de metal / Suporte de metal	46 mm	11
C1		Metal claw Garra de metal / Garra metal	-	30
C26		Foot Pé Atenas / Pie	55x40x100mm	10
E		Wooden dowel Cavilha / Taquete	8x30 mm	80
E3		Shelf bracket Suporte de prateleira / Suporte de repisa	8x7 mm	24
F		Wooden dowel Cavilha / Taquete	8x50 mm	4
G		Structural screw Parafuso estrutural / Tornillo estructural	5,0x50	25
H		Allen key Chave allen / Liave allen	3 mm	2
I		Structural screw cover Tampa parafuso estrutural / Tapa tornillo estructural	-	24
i13		Telescopic slide Corrediça telescópica / Corredera telescópica	350 mm	8
J		Simple minifix screw Haste minifix simples / Tornillo minifix simple	-	18
K		Double minifix screw Haste minifix dupla / Tornillo minifix doble	60mm	4
L		Drum lock Tambor minifix / Tambor minifix	12 mm	26
L9		Flat head screw Parafuso chato / Tornillo de cabeza plana	3,5x12 mm	8
M		Bore patch adhesive Tapa furo adesivo / Tapones adhesivo	-	26
M2		Nut Porca / Tuerca	4 mm	16
N		Nail Prego / Clavo	10x10	138
N7		Wooden dowel Cavilha / Taquete	8x20 mm	16
N17		Metal hinge straight Dobradiça curva / Bisagra recta	35 mm	24

O		Flat head screw Parafuso chato / Tornillo de cabeza plana	4,5x45 mm	8
o5		Flanged head screw Parafuso flangeado / Tornillo de cabeza flangeada	3,5x14 mm	26
Q3		Clothes rack Cabideiro tubo / Perchero	-	2
Q9		Clotes rack support Suporte cabideiro / Soporte perchero	-	4
S		Pan head screw Parafuso panela / Tornillo de pan	3,5x14 mm	194
T8		Flat head screw Parafuso chato / Tornillo de cabeza plana	3,5x35 mm	16
U5		Flat head screw Flat head screw / Flat head screw	4,0x25 mm	16
Z		Plastic hole plugs Tapa furo plástico / Tapones plásticos	8 mm	4

SEPARATE THE TWO PARTS OF THE METAL SLIDE TO THE ASSEMBLY FOLLOWING THE INSTRUCTIONS BELOW.
SEPARA AS DUAS PARTES DA CORREDIÇA METÁLICA PARA A MONTAGEM SEGUINDO AS INSTRUÇÕES ABAIXO.
SEPARAR LAS DOS PARTES DE LA CORREDERA DE METAL PARA EL ARMADO Y SEGUIR A LAS INSTRUCCIONES ABAJO.

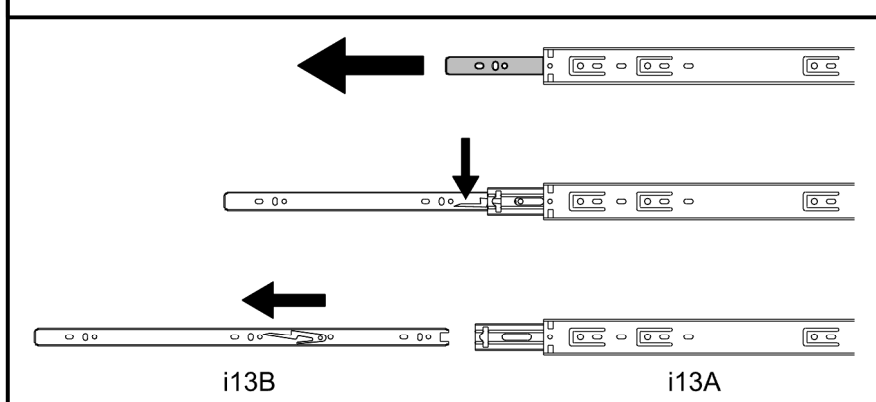

PRE-ASSEMBLE
PRÉ-MONTAGEM / PRE ARMADO

01

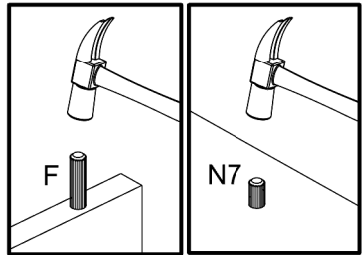
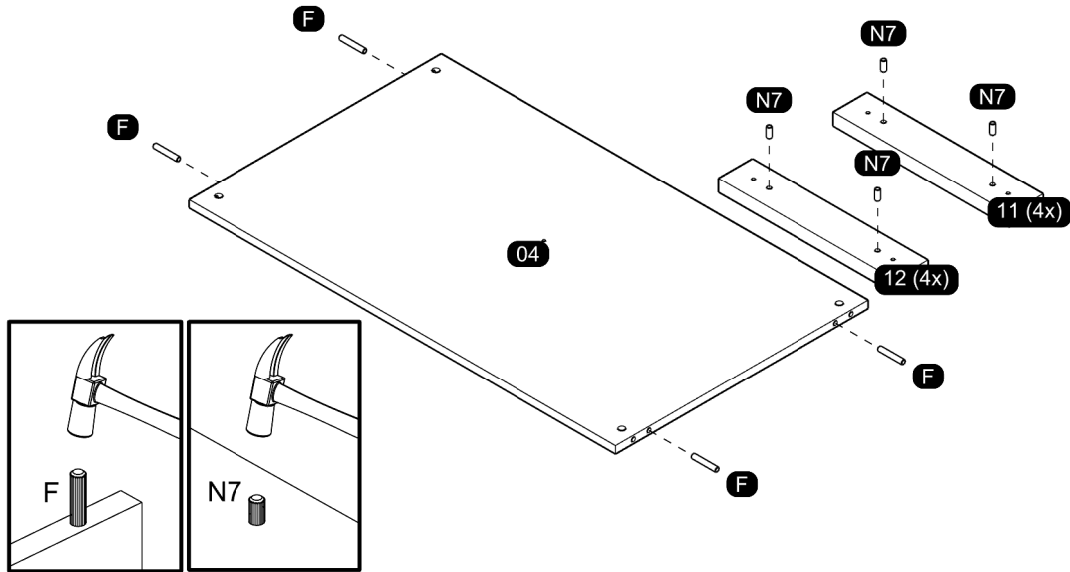

03

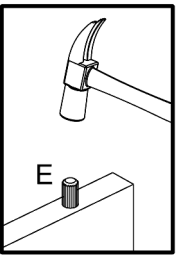
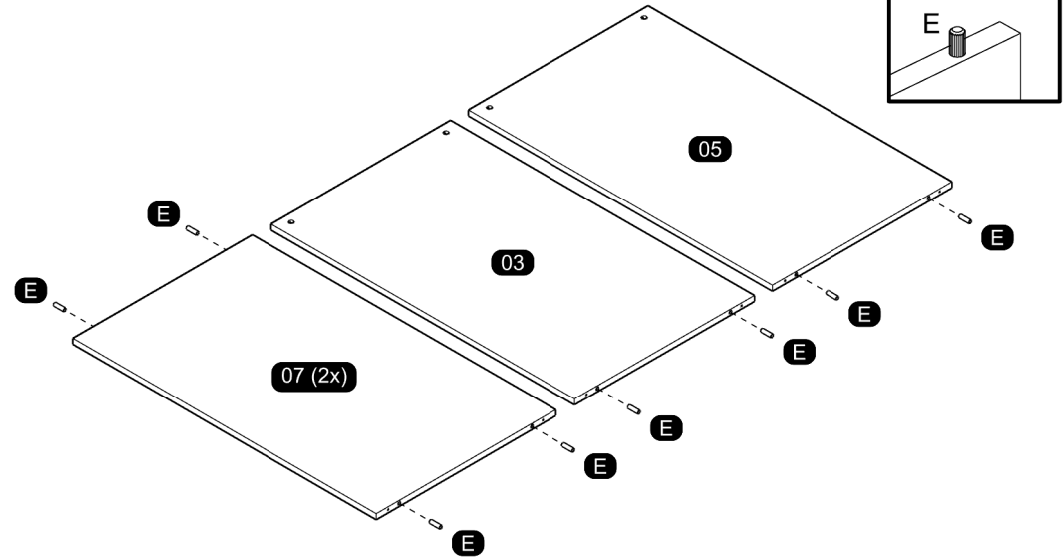

02

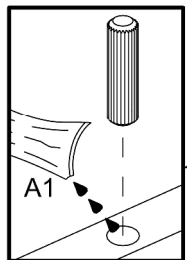
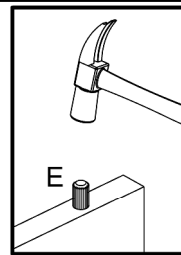
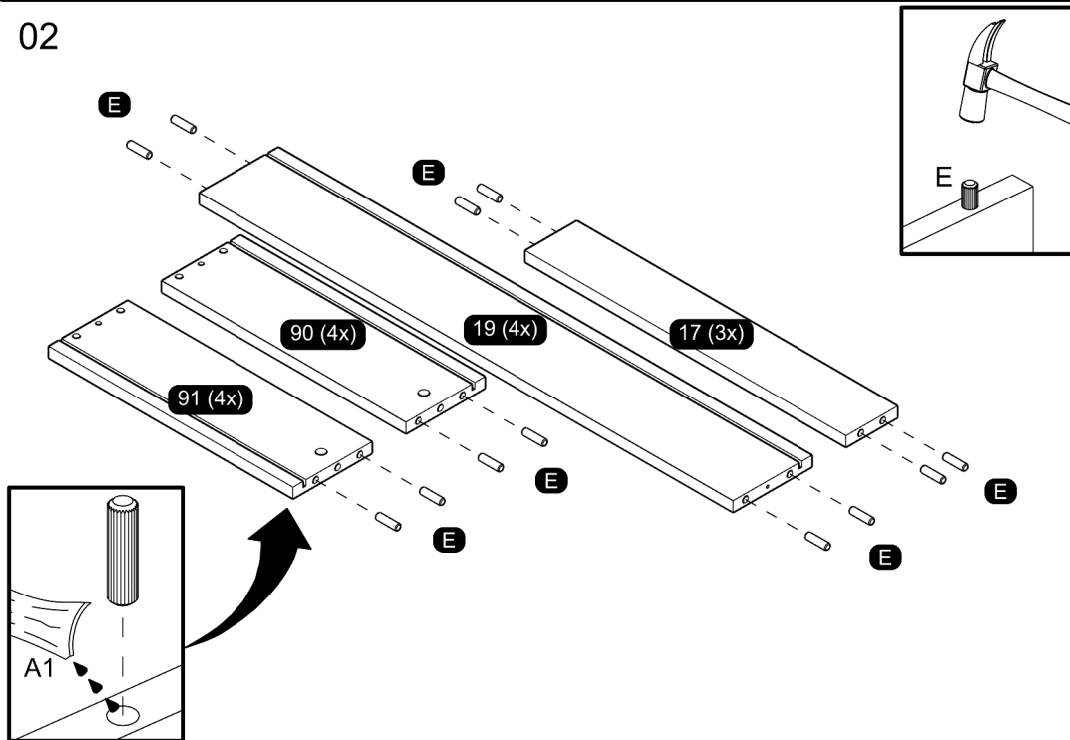

04

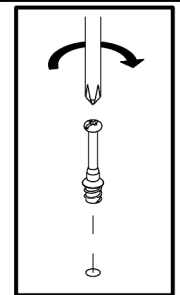
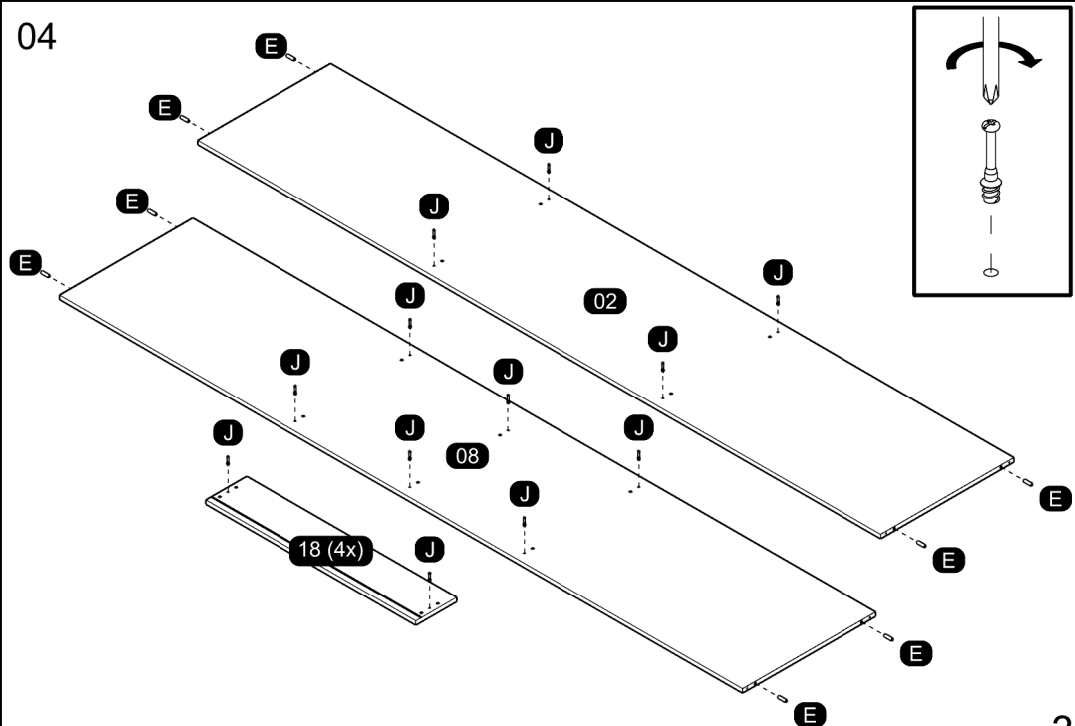

05

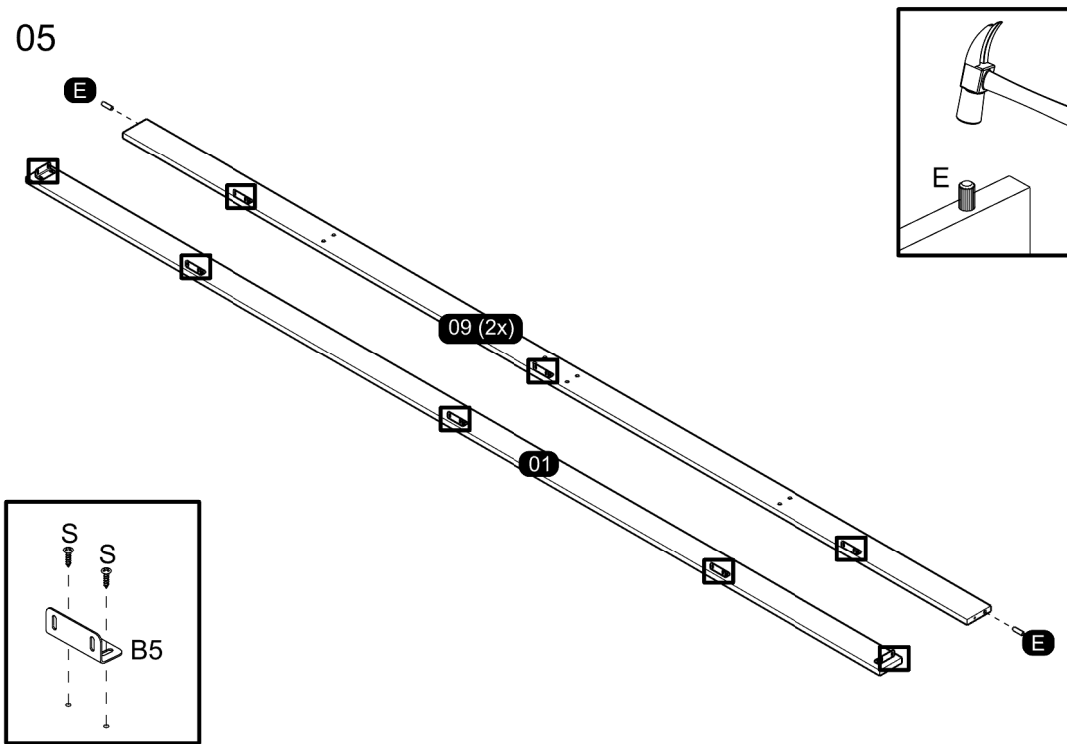

07

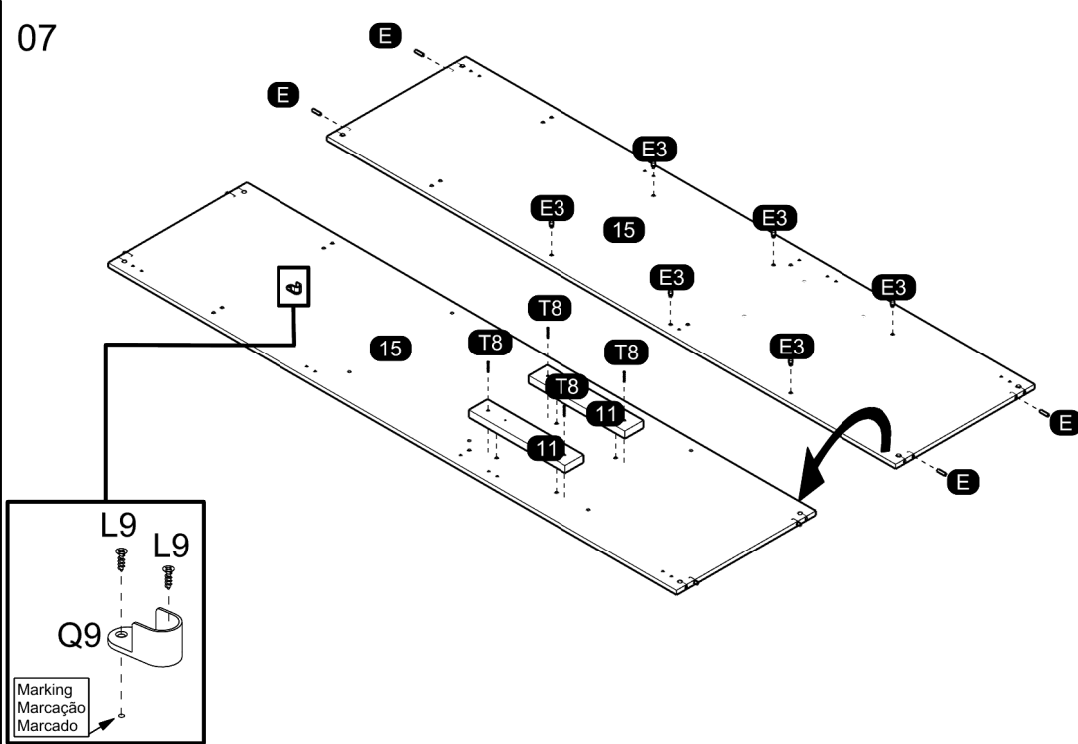

06

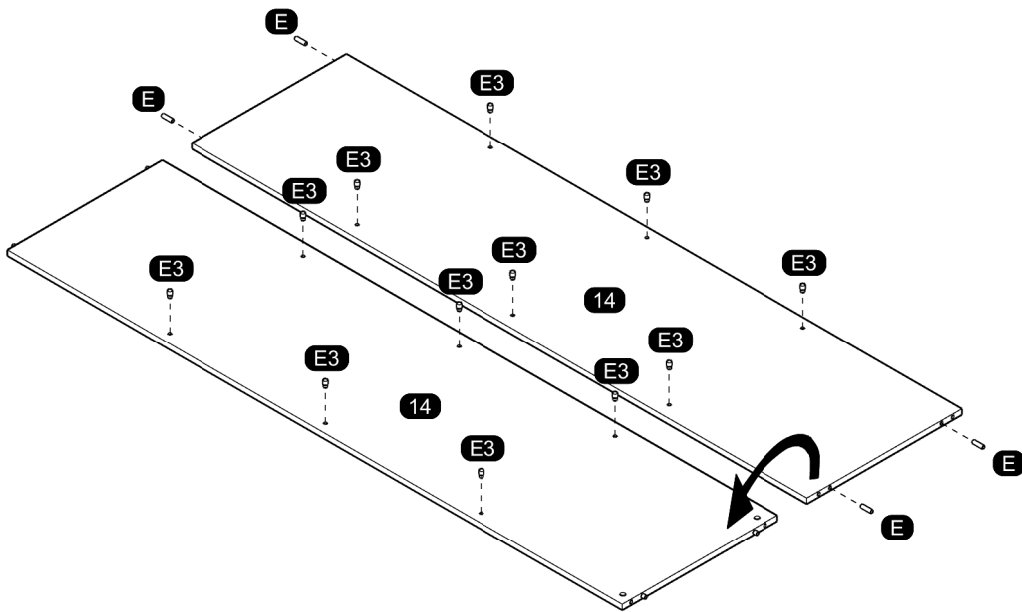

08

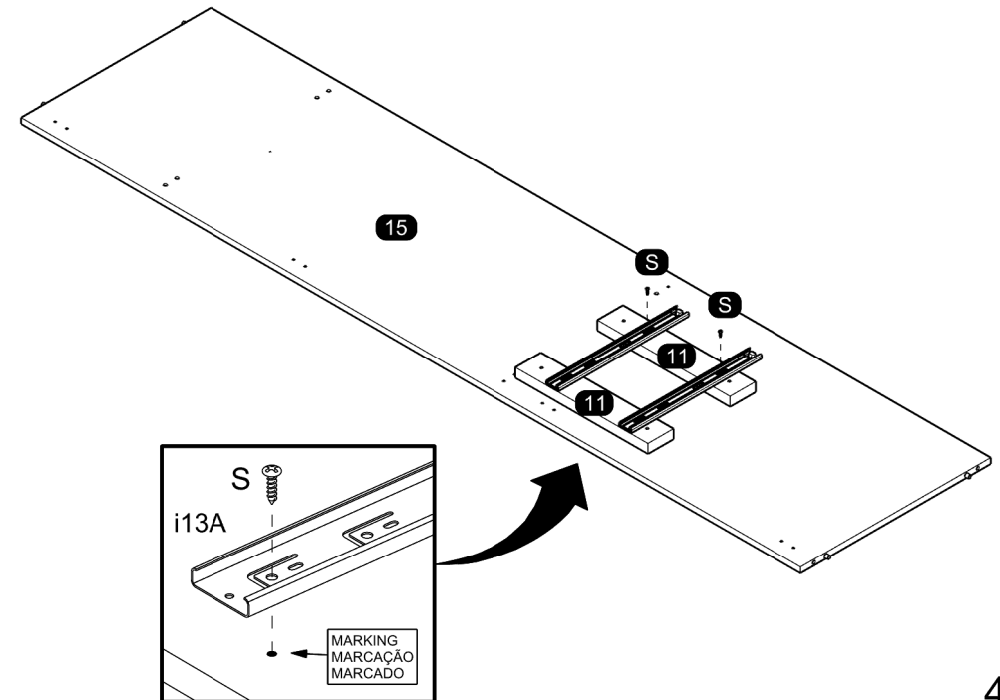

09

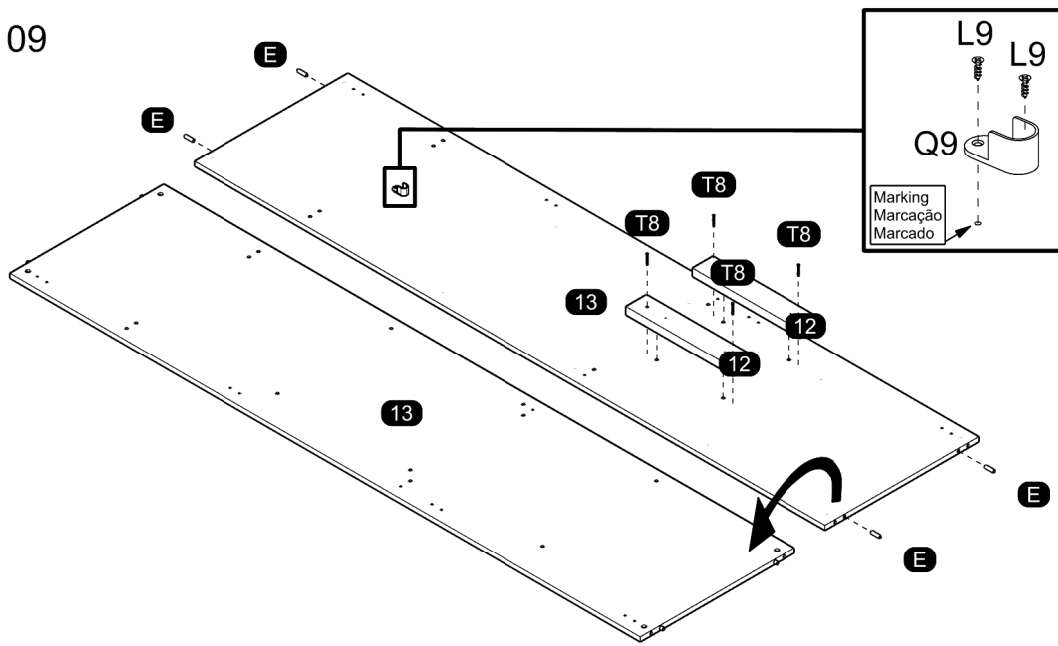

11

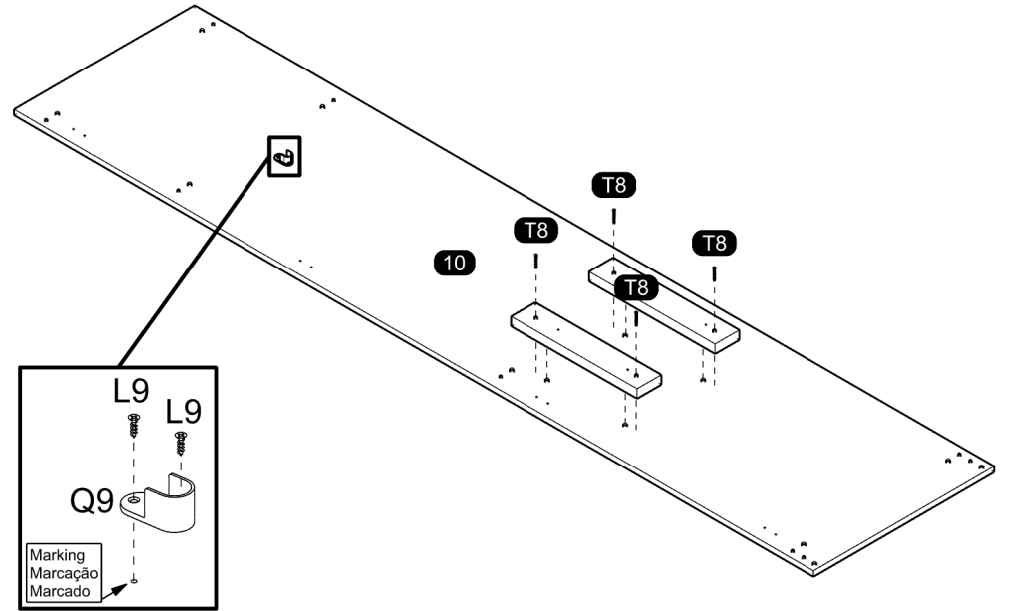

10

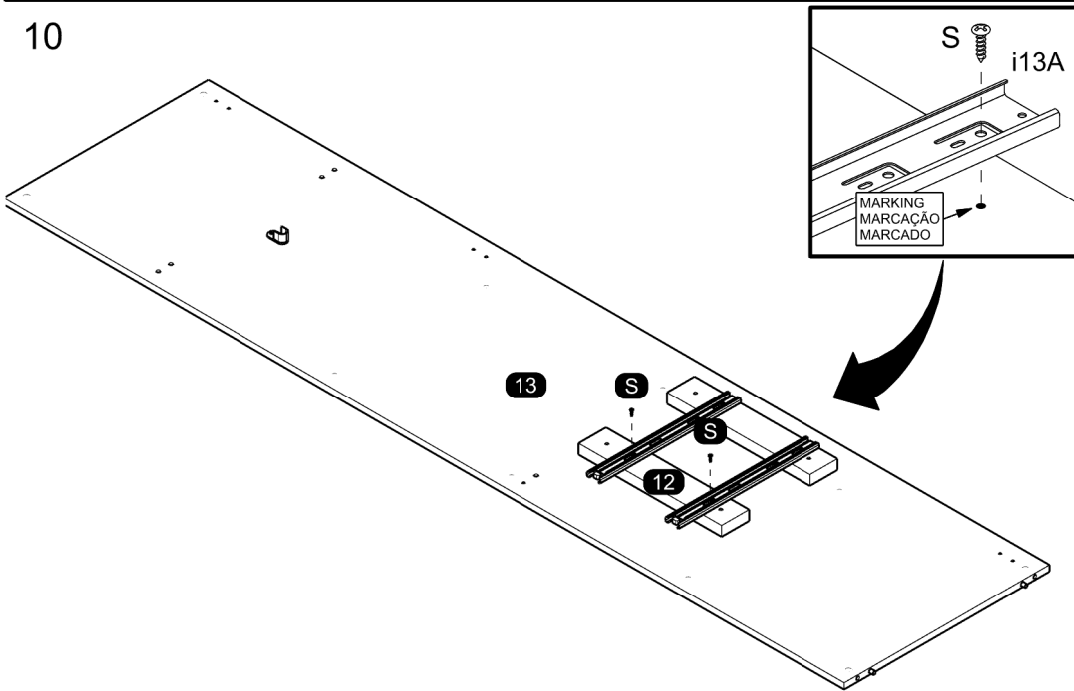

12

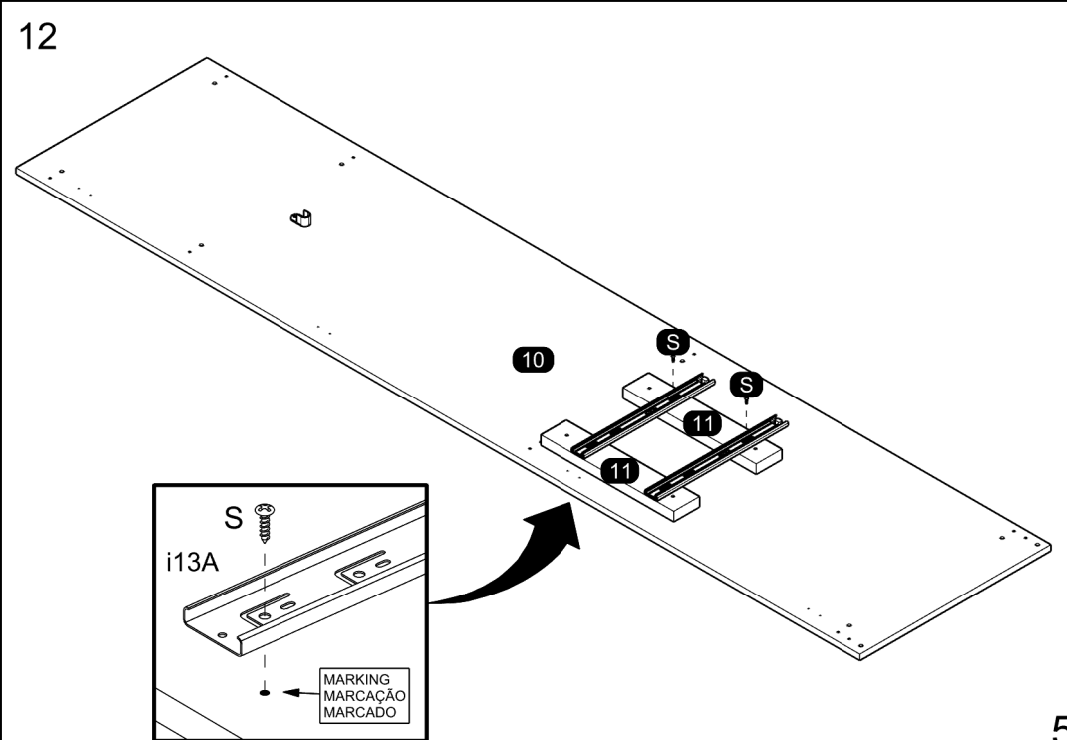

13

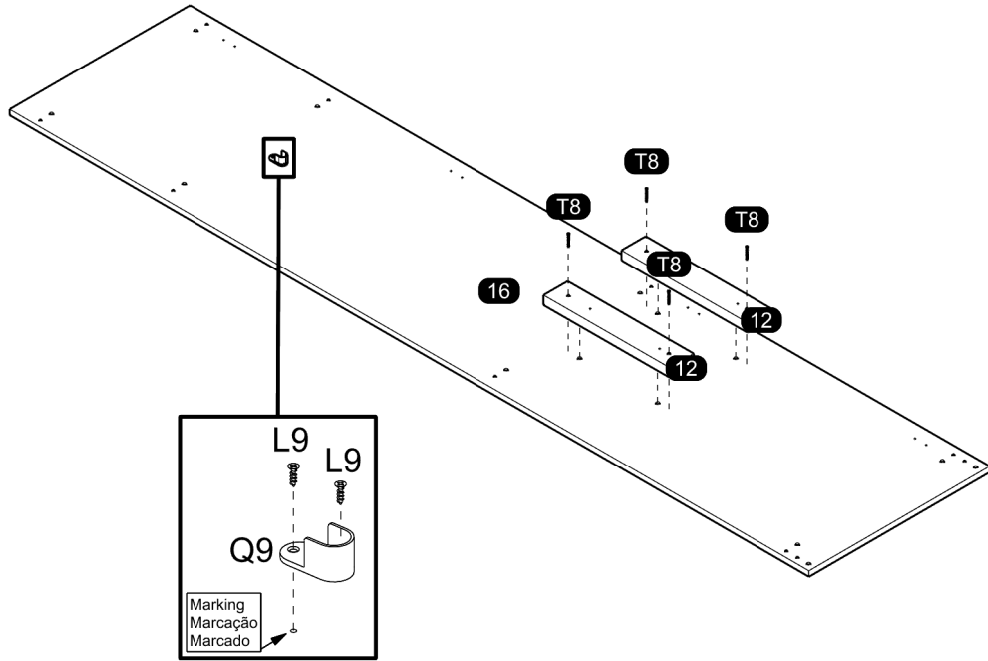

**ASSEMBLY
MONTAGEM / ARMADO**

15

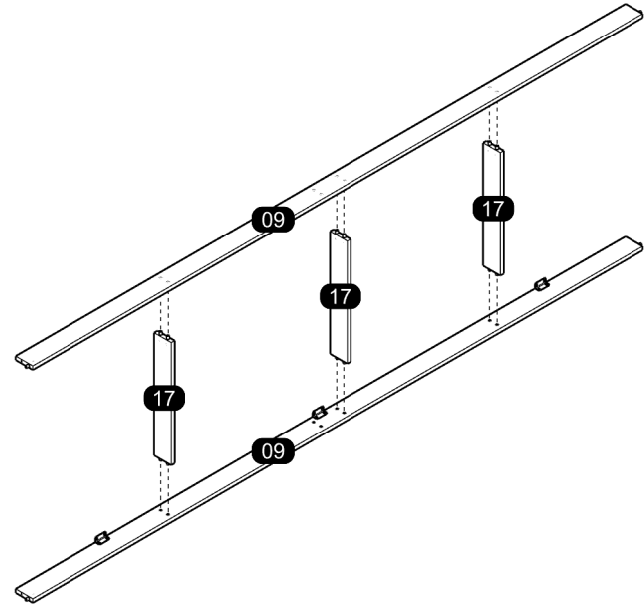

14

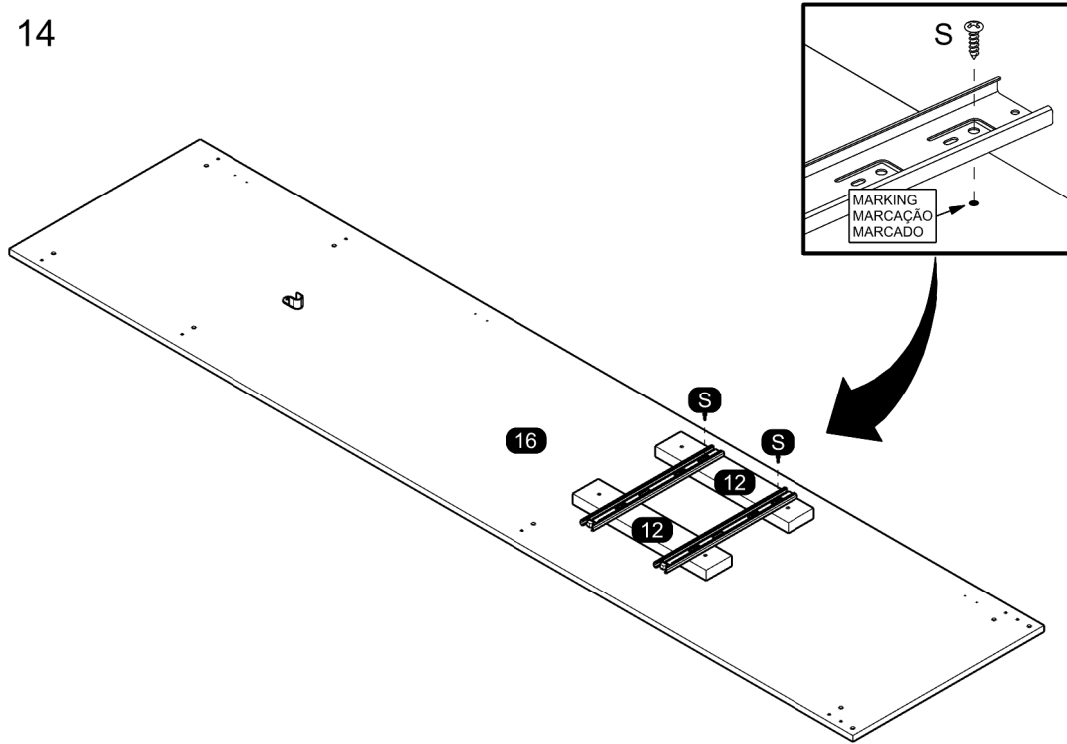

16

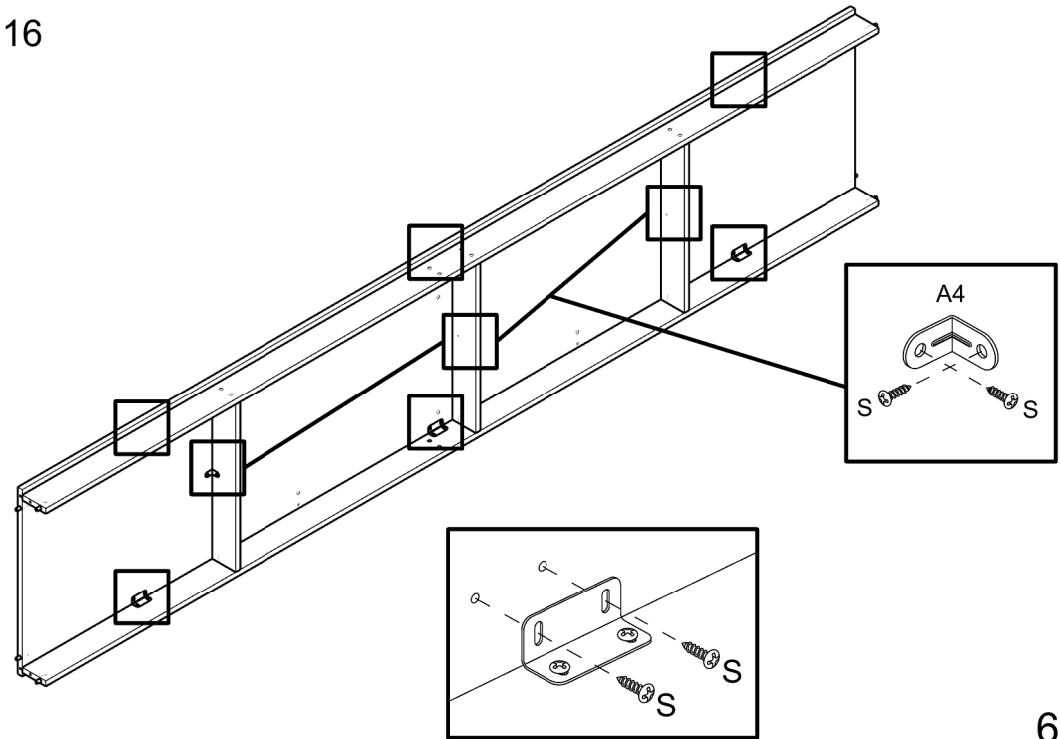

17

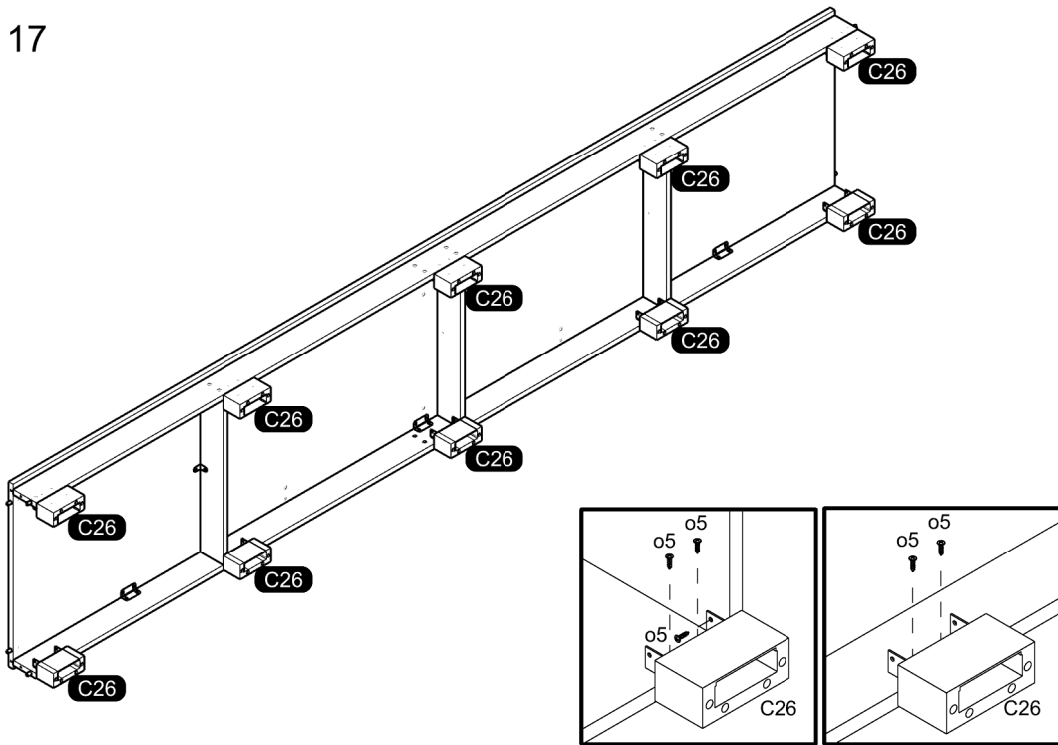

19

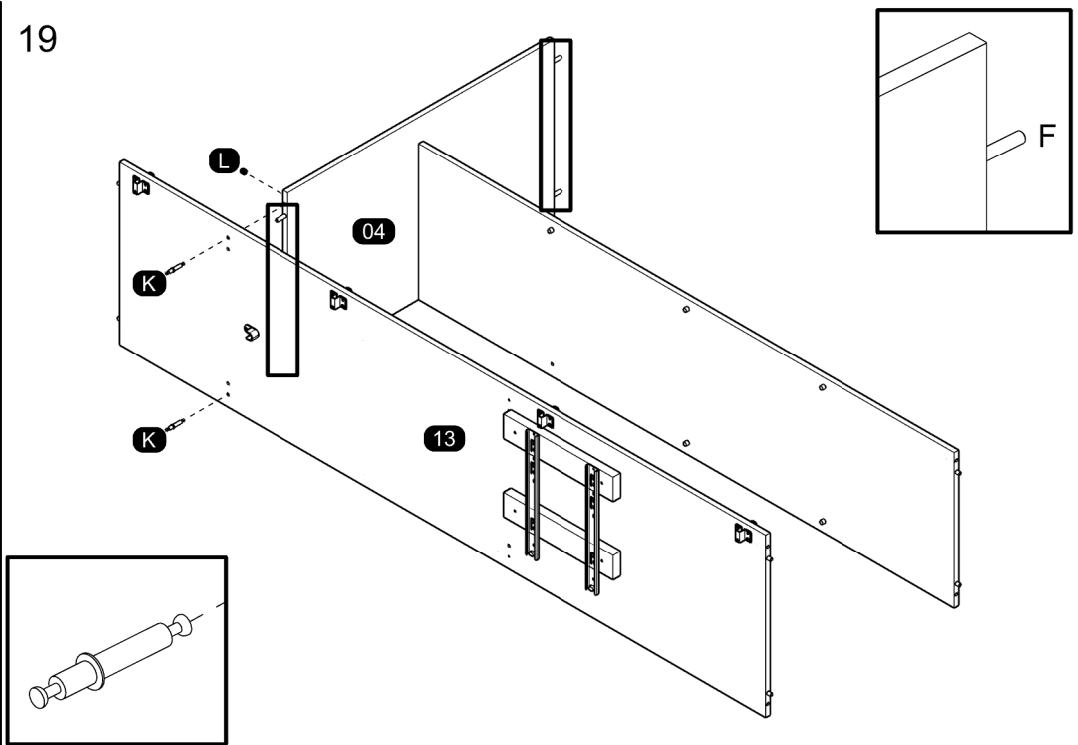

18

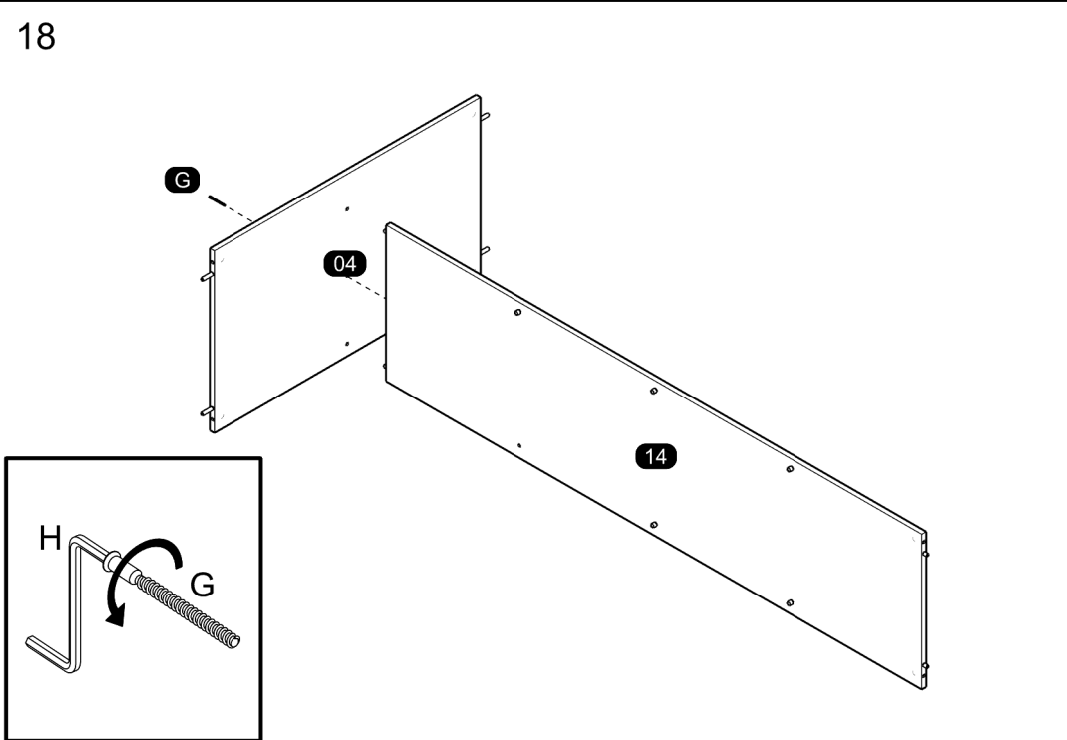

20

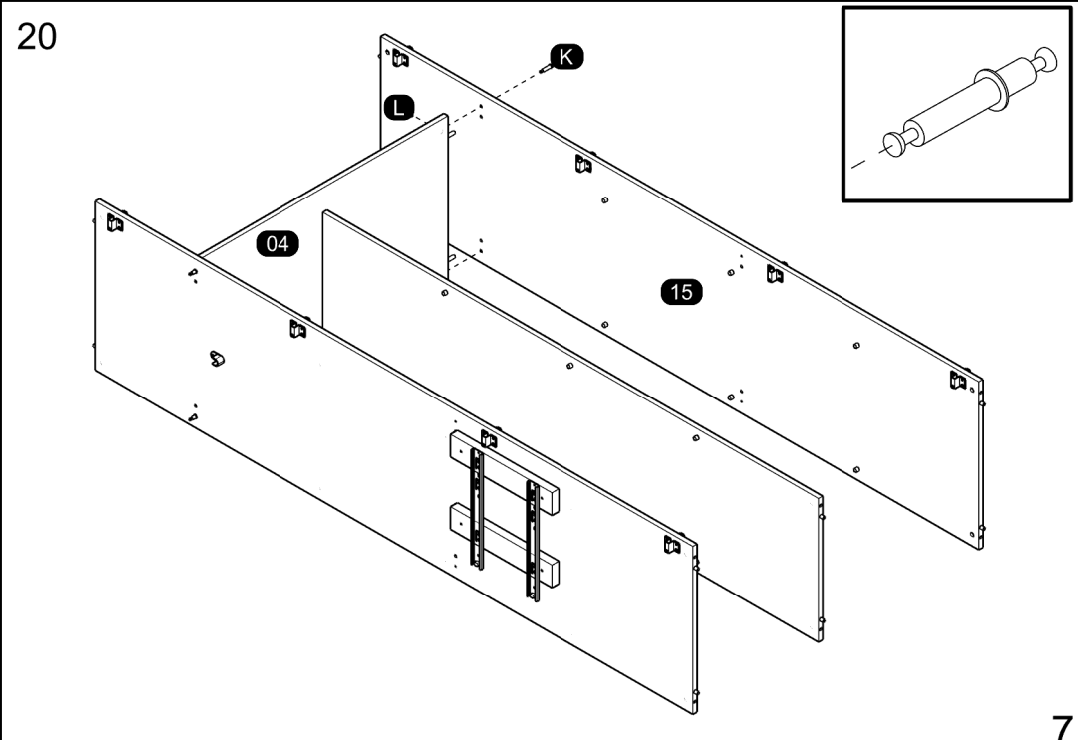

21

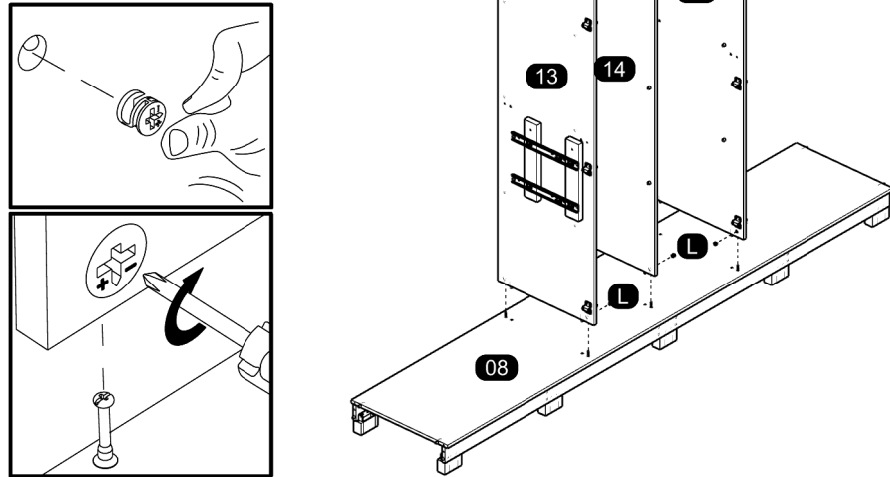

23

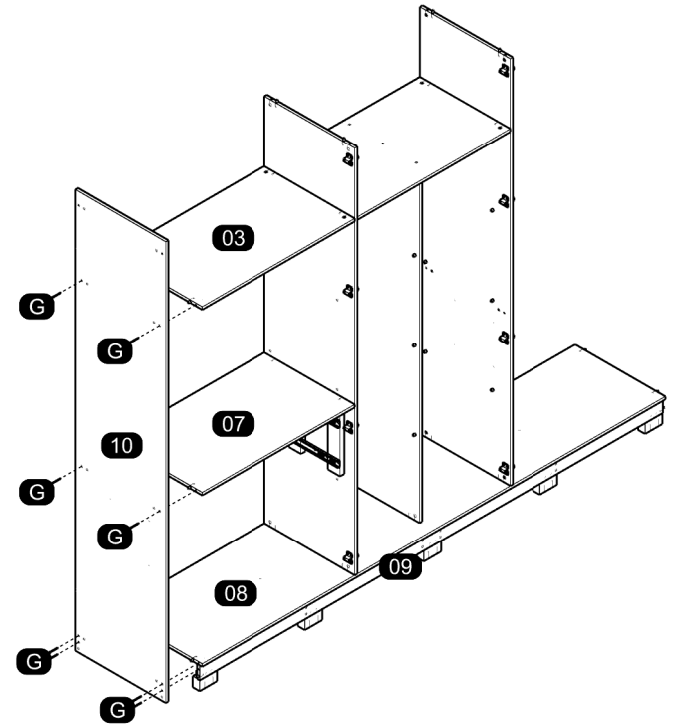
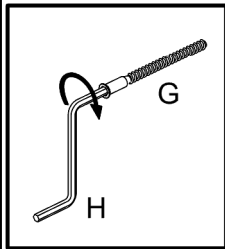

22

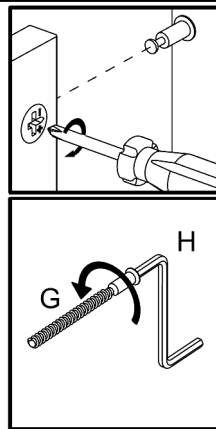
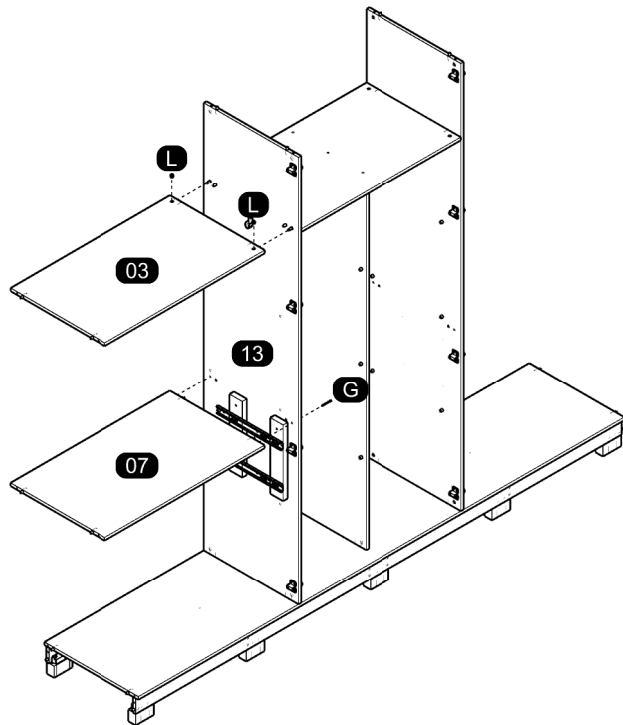

24

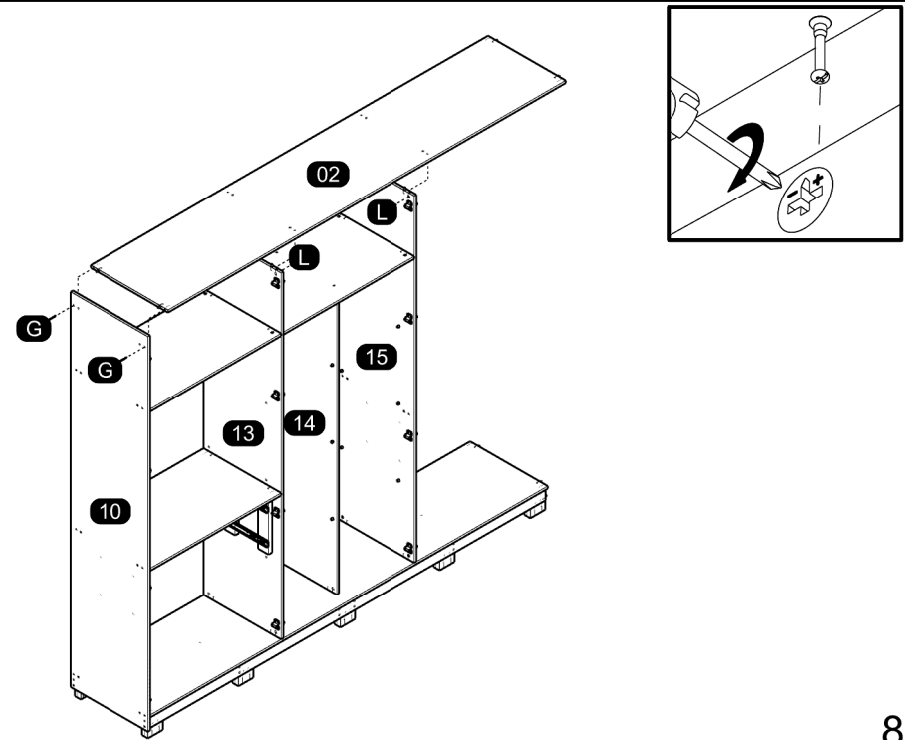

25

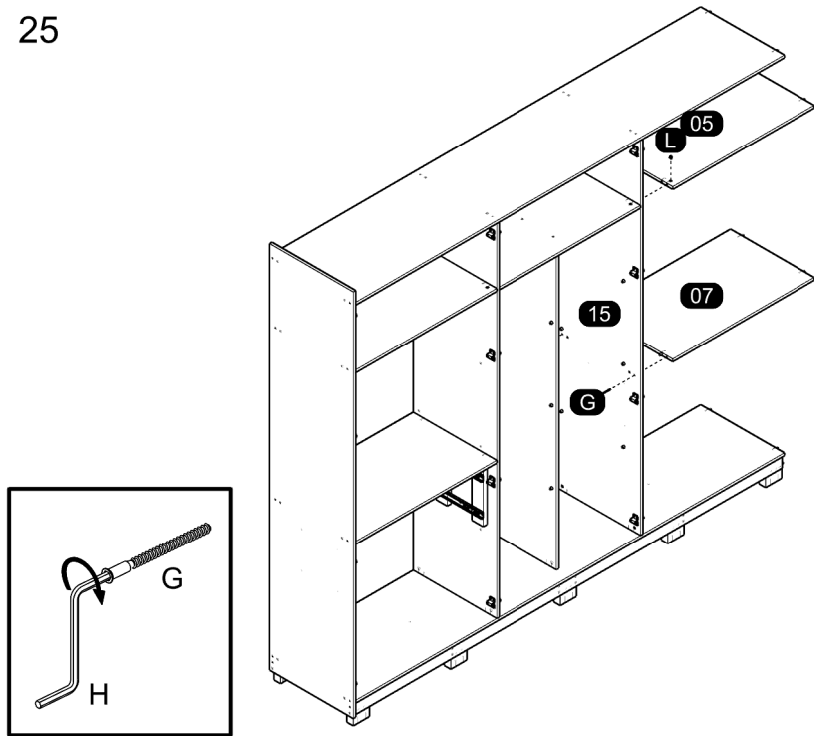

27

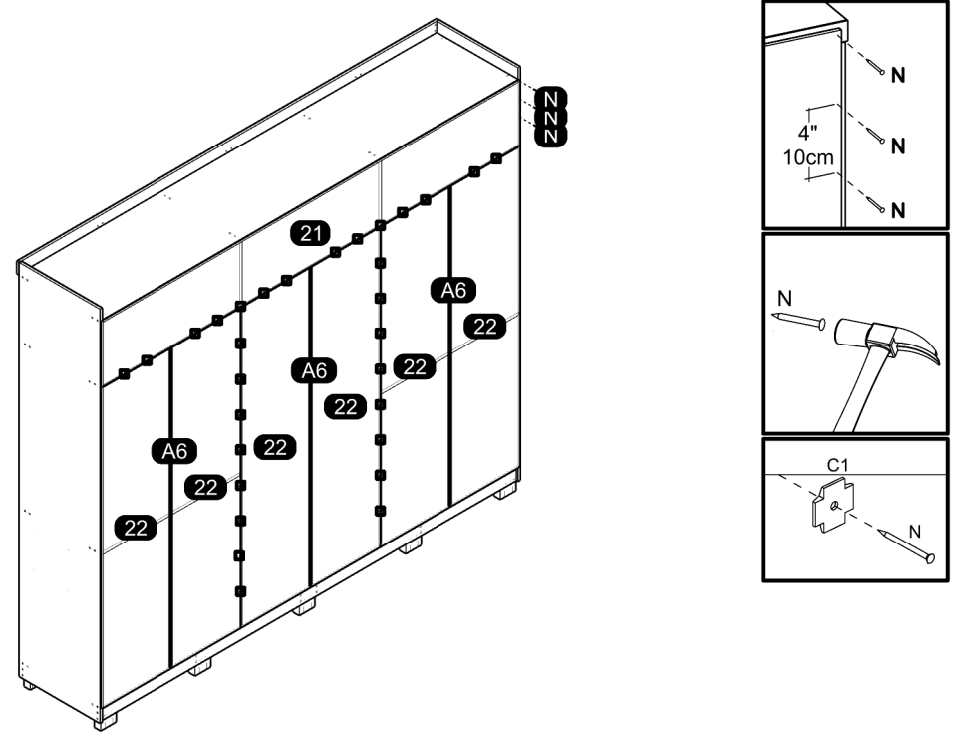

26

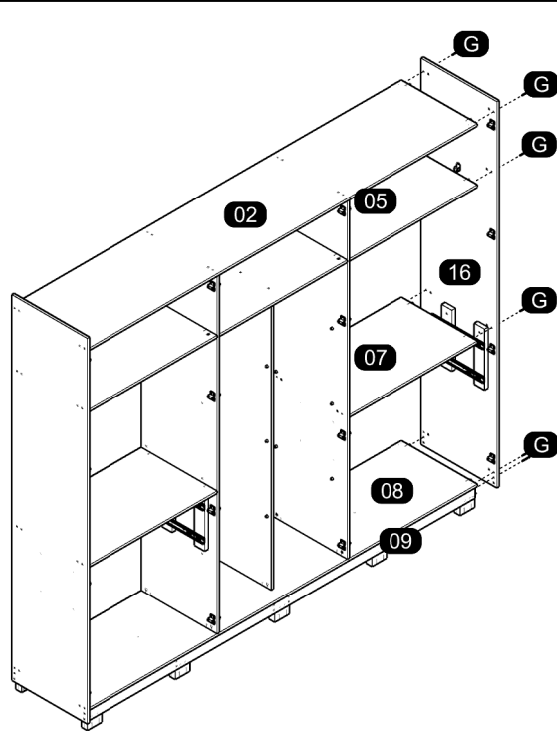

28

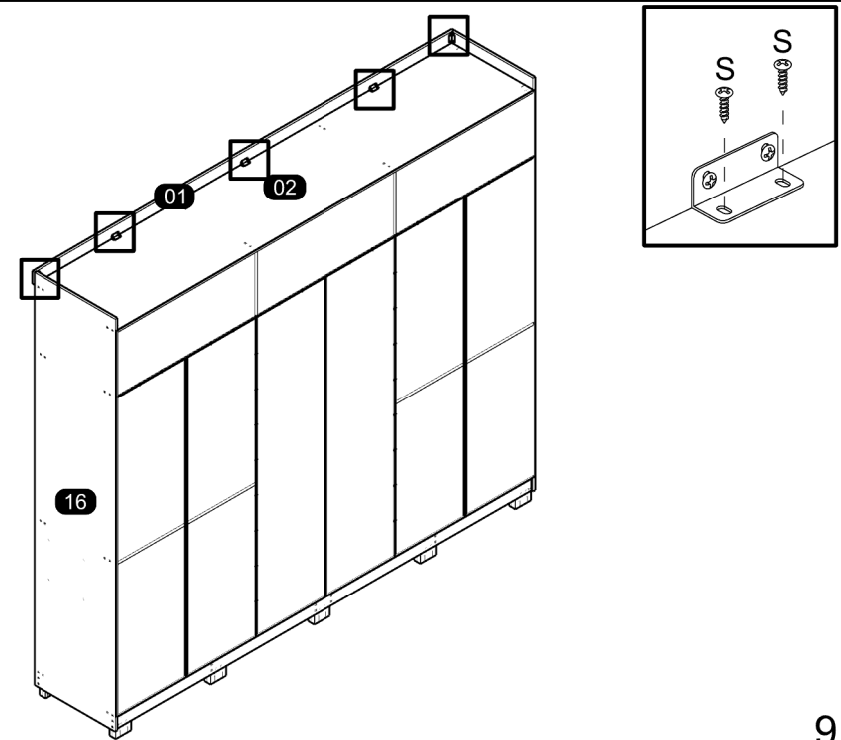

29

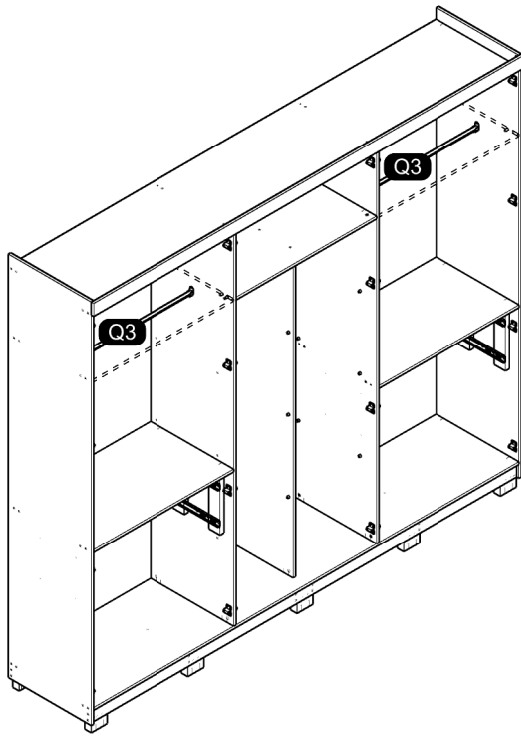
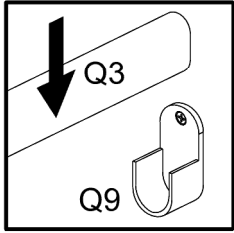

31

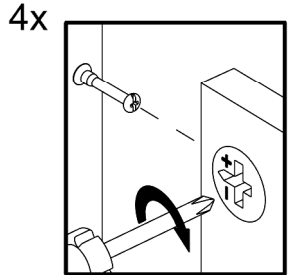
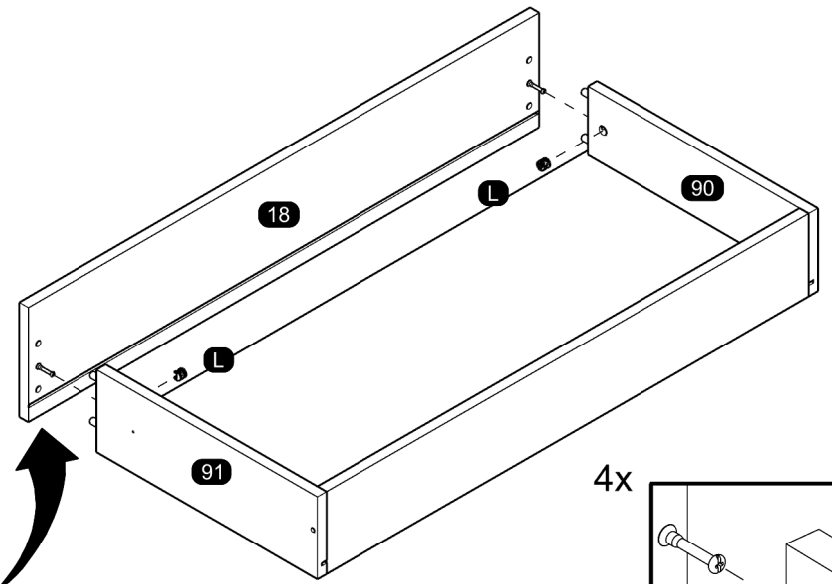
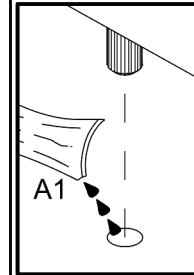

30

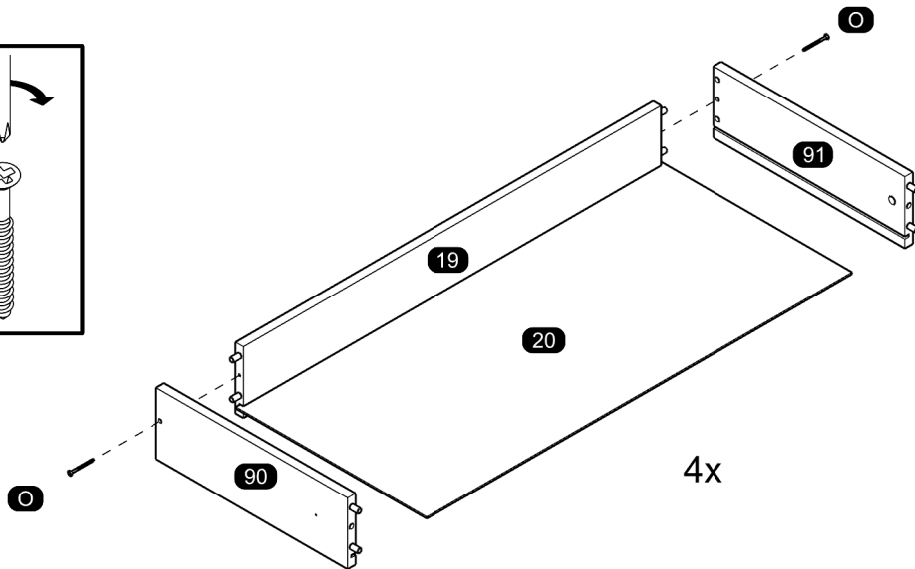
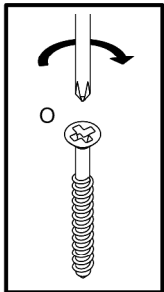

32

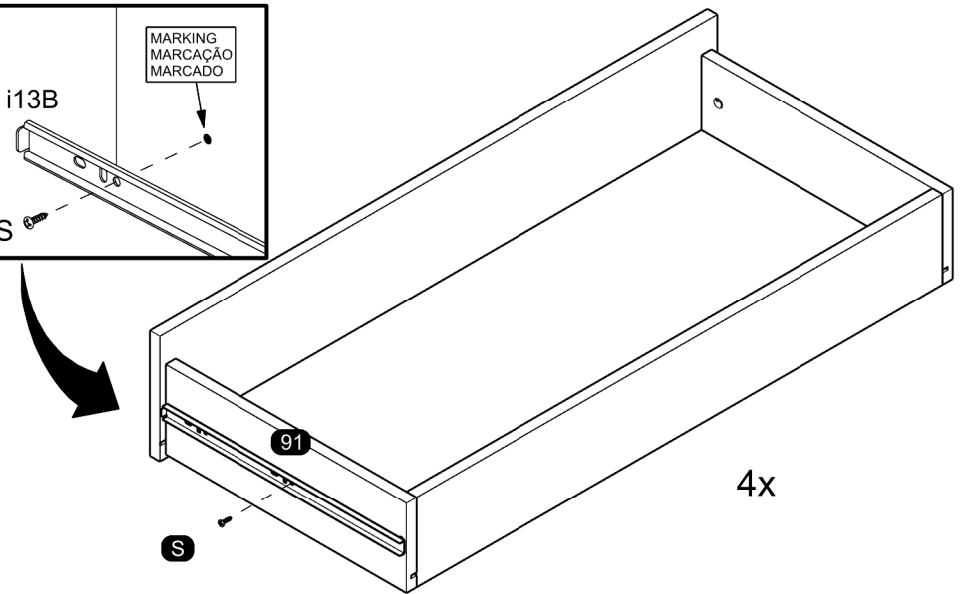
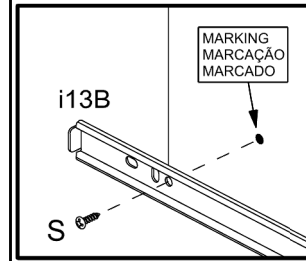

33

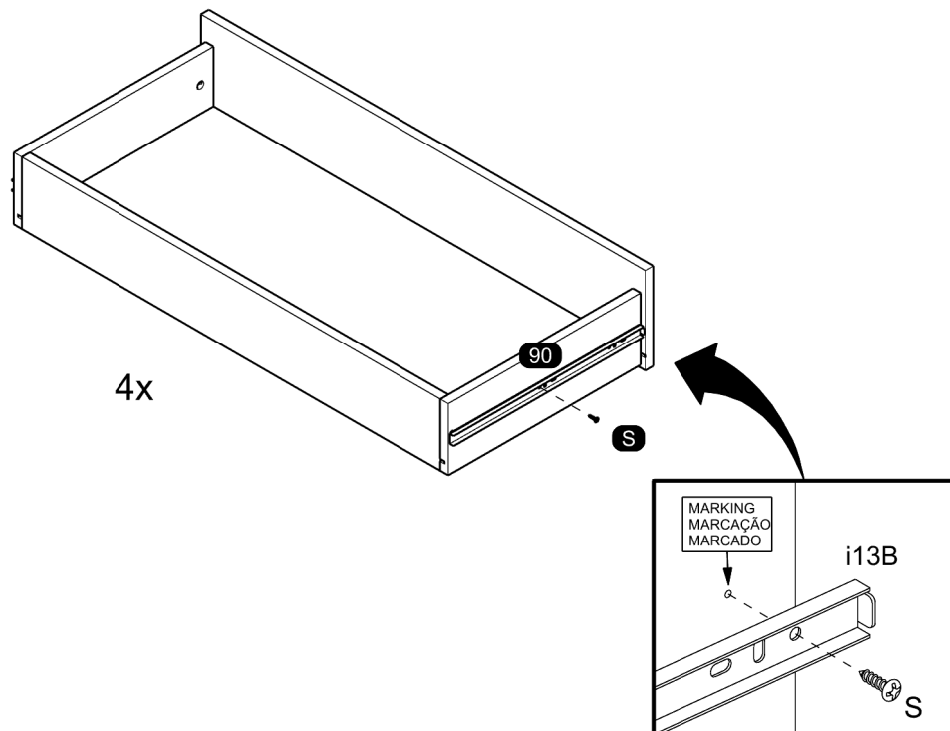

35

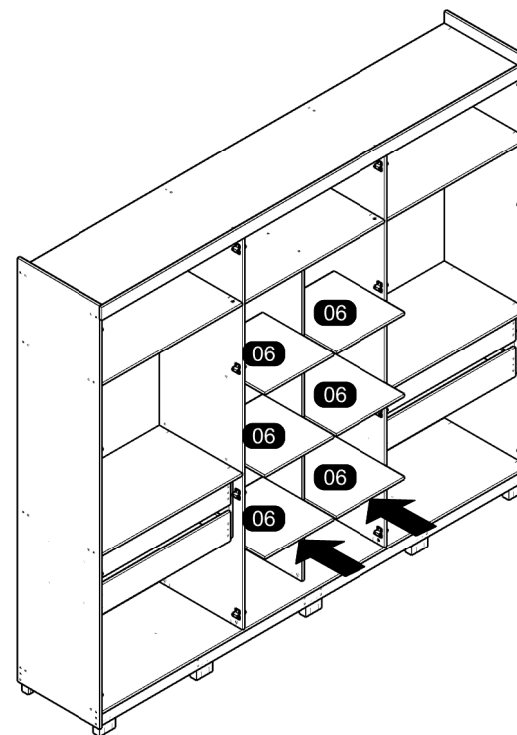

34

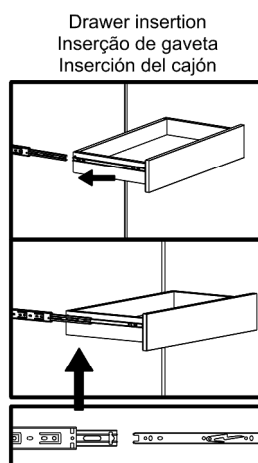
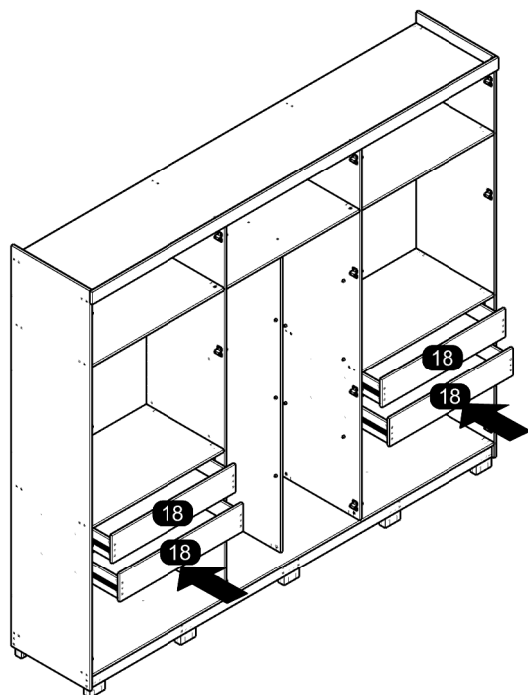

36

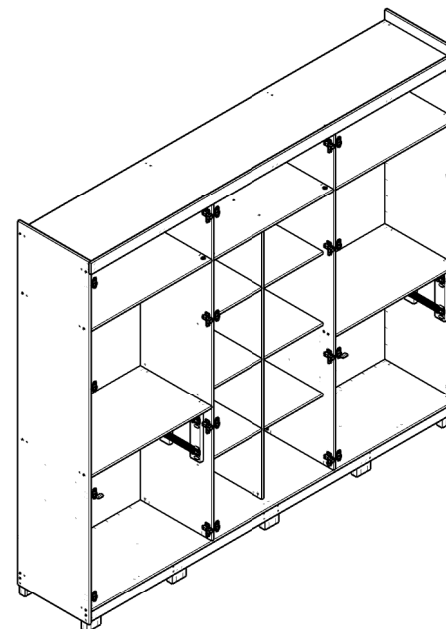

At the end of the assembly, insert the screw cover / hole plugs in the apparent holes.
Ao final da montagem, insira a(s) tampa(s) de parafuso / tapa furos nos furos que ficarem aparentes.
Al final del conjunto, coloque la tapa tornillo / tapón plástico en los agujeros que se hagan evidentes.

37

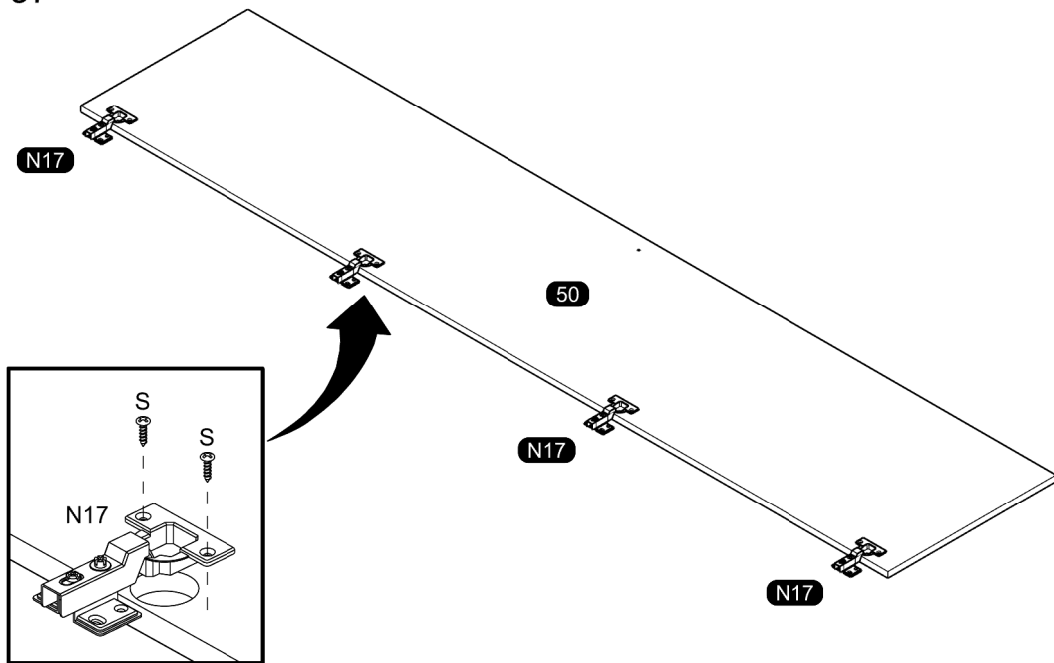

39

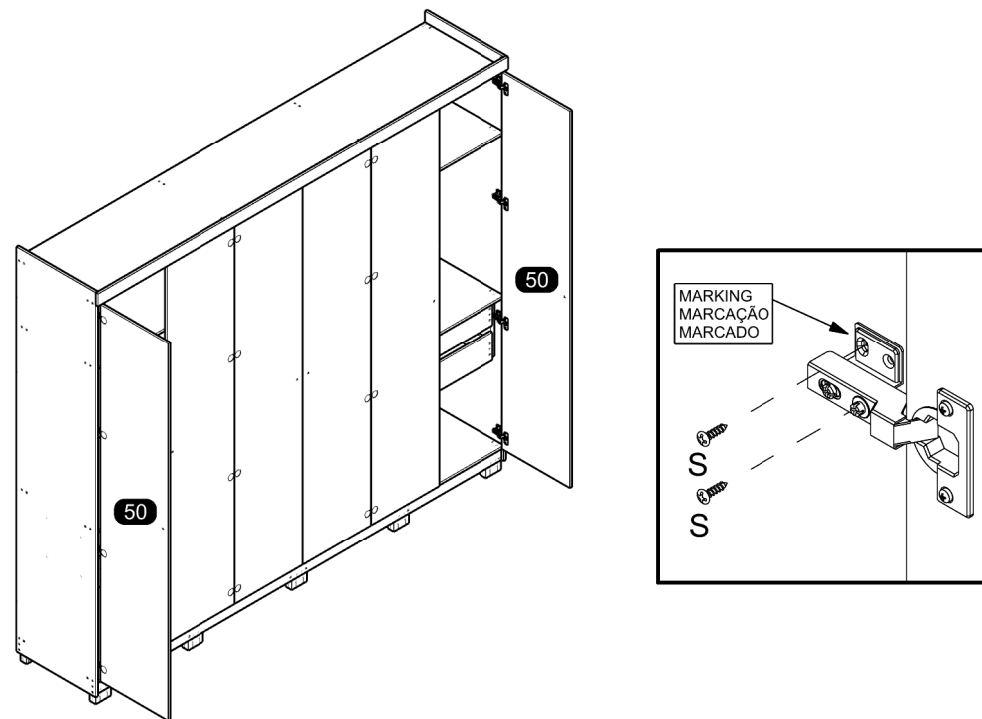

38

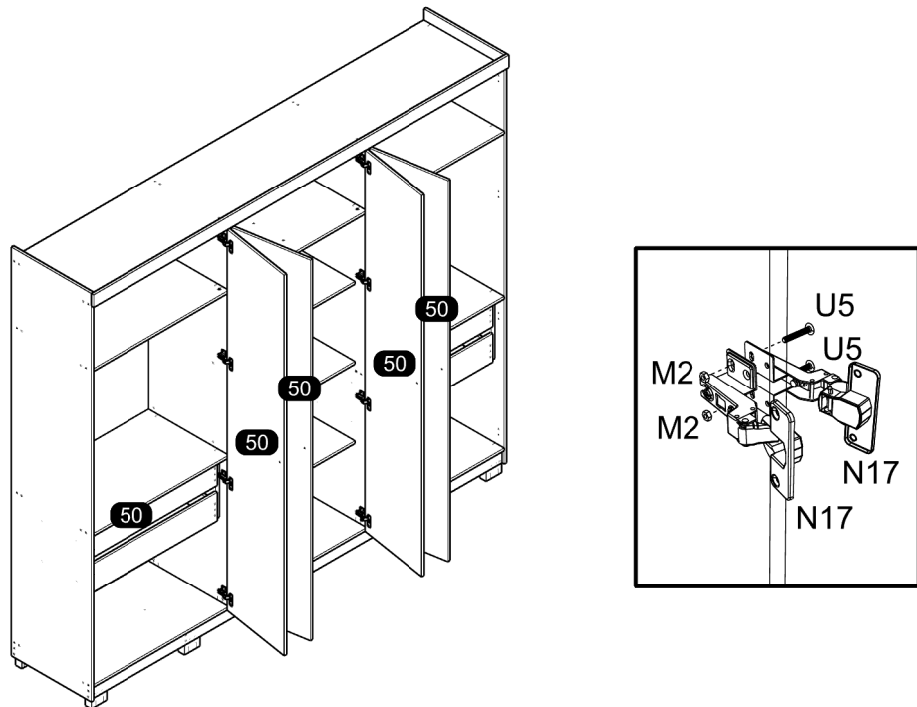

40

