

# ASSEMBLY INSTRUCTIONS MANUAL DE MONTAGEM / INSTRUCCIONES DE ARMADO

WARDROBE 6 DOORS  
ROUPEIRO 6 PORTAS  
ROPERO 6 PUERTAS

Reference  
Referência  
Referencia **240937** | Revise  
| Revisão  
| Revisión **00**

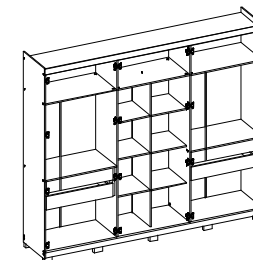

## YOU WILL NEED VOCÊ VAI PRECISAR DE / USTED NECESITARÁ

Tools not supplied  
Ferramentas não fornecidas / Herramientas no incluidas

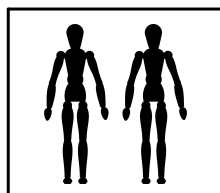

2 People  
2 Pessoas  
2 Personas

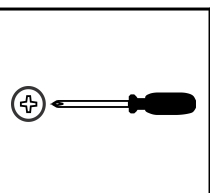

Screwdriver Phillips  
Chave Phillips  
Destornillador cruz

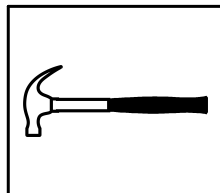

Hammer  
Martelo  
Martillo

## PARTS IDENTIFICATION IDENTIFICAÇÃO DAS PEÇAS / IDENTIFICACIÓN DE LAS PIEZAS

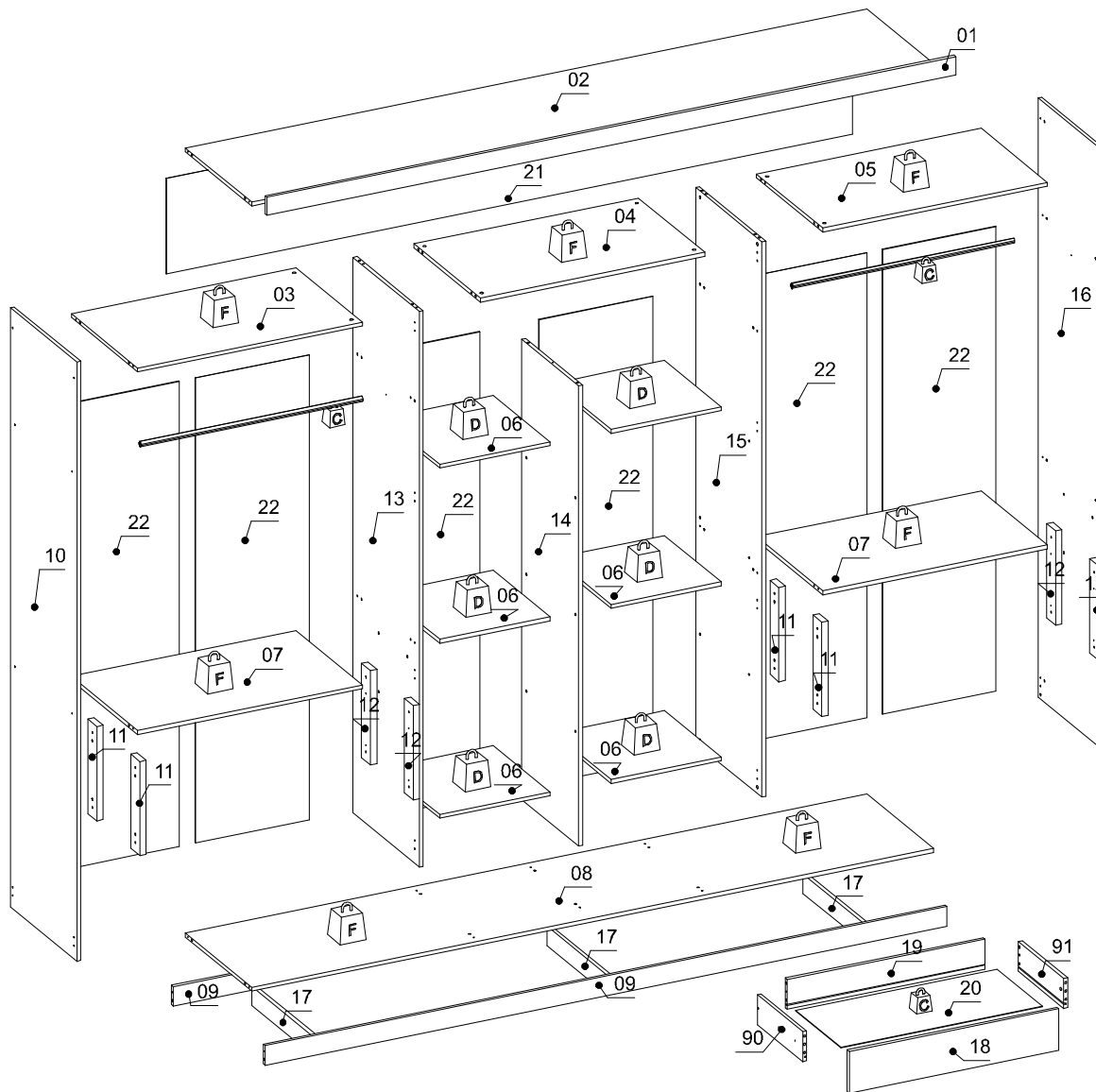

Nº	Measures_Inches	Medidas_cm	Qty./Qtd.
01	106 1/8 x 23 3/4 x 5/8	269.7 x 7.0 x 1.5	1
02	105 x 20 1/2 x 5/8	266.7 x 52.0 x 1.5	1
03	34 5/8 x 20 1/2 x 5/8	87.9 x 52.0 x 1.5	1
04	34 5/8 x 20 1/2 x 5/8	87.9 x 52.0 x 1.5	1
05	34 5/8 x 20 1/2 x 5/8	87.9 x 52.0 x 1.5	1
06	17 x 17 1/2 x 5/8	43.2 x 44.5 x 1.5	6
07	34 5/8 x 20 1/2 x 5/8	87.9 x 52.0 x 1.5	2
08	105 x 20 1/2 x 5/8	266.7 x 52.0 x 1.5	1
09	105 x 3 x 5/8	266.7 x 7.5 x 1.5	2
10	90 1/2 x 20 1/2 x 5/8	230.0 x 52.0 x 1.5	1
11	14 1/4 x 2 3/4 x 1	36.2 x 7.0 x 2.5	4
12	14 1/4 x 2 3/4 x 1	36.2 x 7.0 x 2.5	4
13	83 7/8 x 20 1/2 x 5/8	213.2 x 52.0 x 1.5	1
14	69 5/8 x 17 1/2 x 5/8	176.7 x 44.5 x 1.5	1
15	83 7/8 x 20 1/2 x 5/8	213.2 x 52.0 x 1.5	1
16	90 1/2 x 20 1/2 x 5/8	230.0 x 52.0 x 1.5	1
17	18 1/4 x 3 x 5/8	46.5 x 7.5 x 1.5	3
18	32 3/8 x 6 1/4 x 5/8	82.1 x 16.0 x 1.5	4
19	30 1/2 x 4 1/2 x 5/8	77.4 x 11.5 x 1.5	4
20	31 x 13 7/8 x 1/8	78.8 x 35.4 x 0.3	4
21	105 3/4 x 14 1/2 x 1/8	268.7 x 36.7 x 0.3	1
22	70 1/4 x 17 1/2 x 1/8	178.4 x 44.4 x 0.3	6
90	14 x 4 1/2 x 5/8	35.5 x 11.5 x 1.5	4
91	14 x 4 1/2 x 5/8	35.5 x 11.5 x 1.5	4

 MAXIMUM RECOMMENDED WEIGHT BEING THIS EVENLY DISTRIBUTED.  
PESO MÁXIMO RECOMENDADO SENDO ESTE DISTRIBUÍDO UNIFORMEMENTE.  
PESO MÁXIMO RECOMENDADO SIENDO ESTE UNIFORMEMENTE DISTRIBUIDO.

	LB	KG
—		
C	6	3
D	11	5
F	22	10



PRE-ASSEMBLE  
PRÉ-MONTAGEM / PRE ARMADO

01

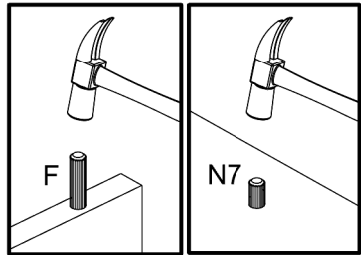
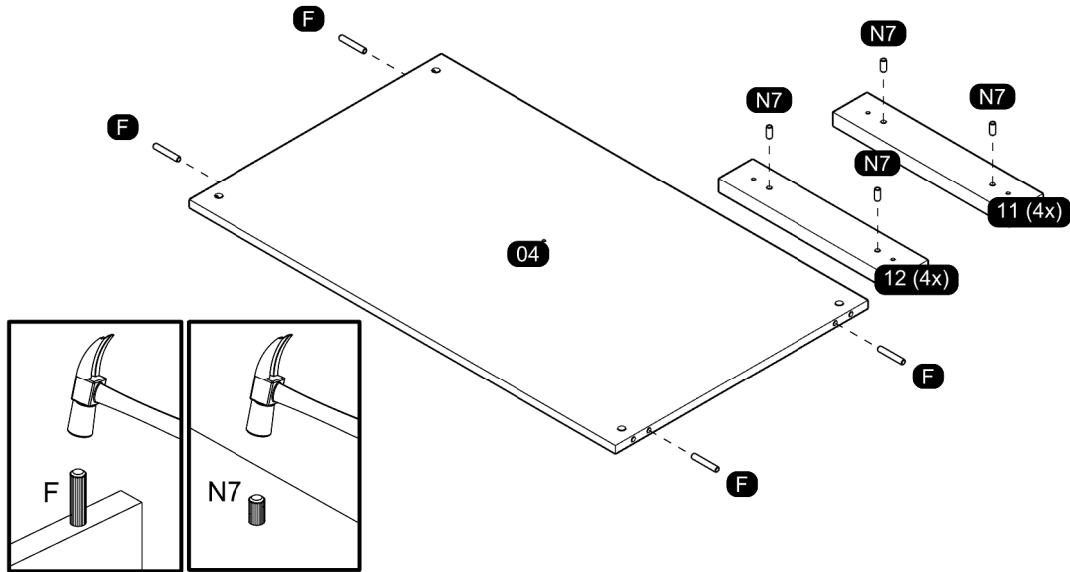

03

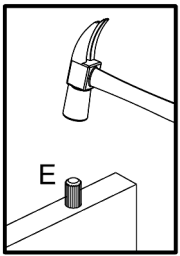
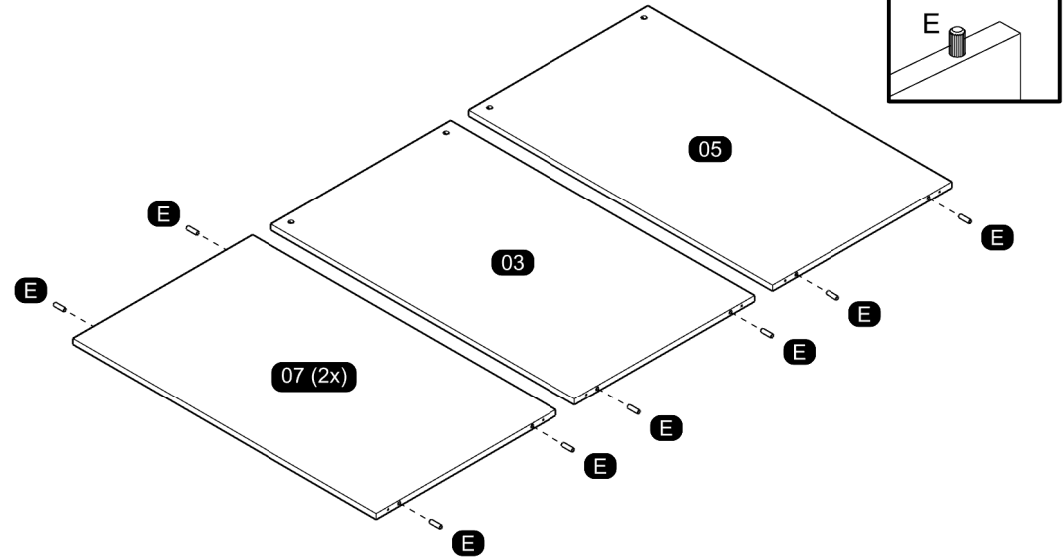

02

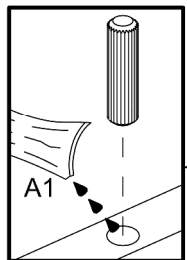
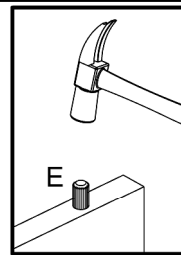
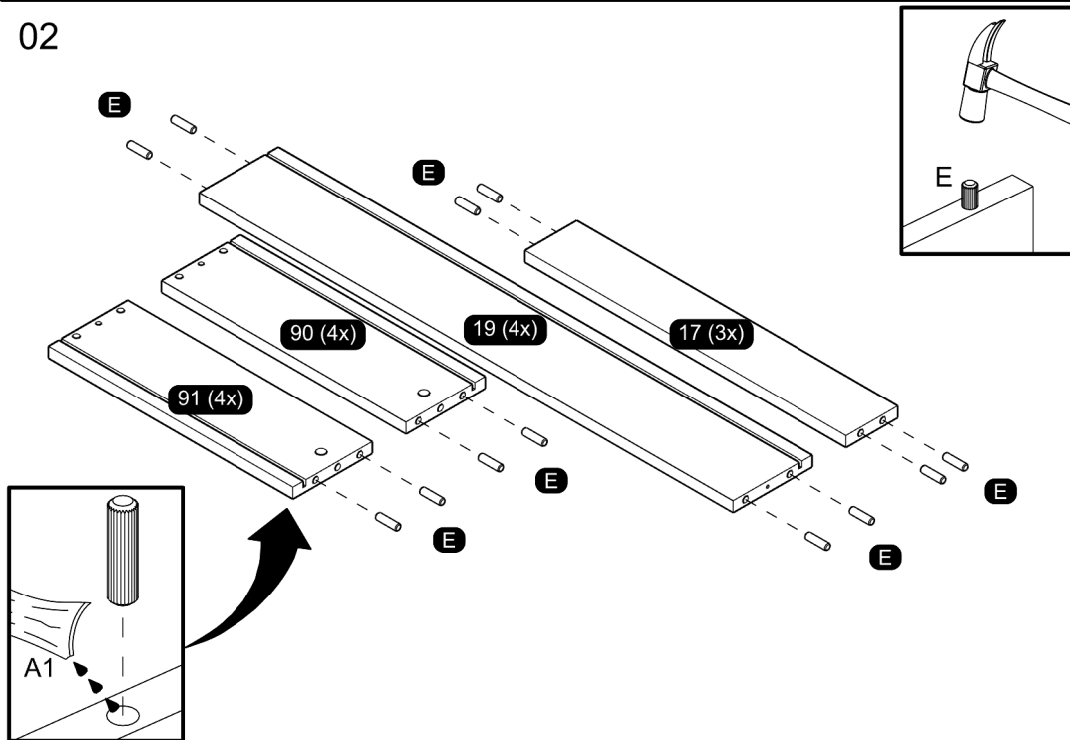

04

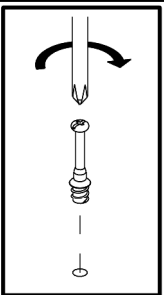
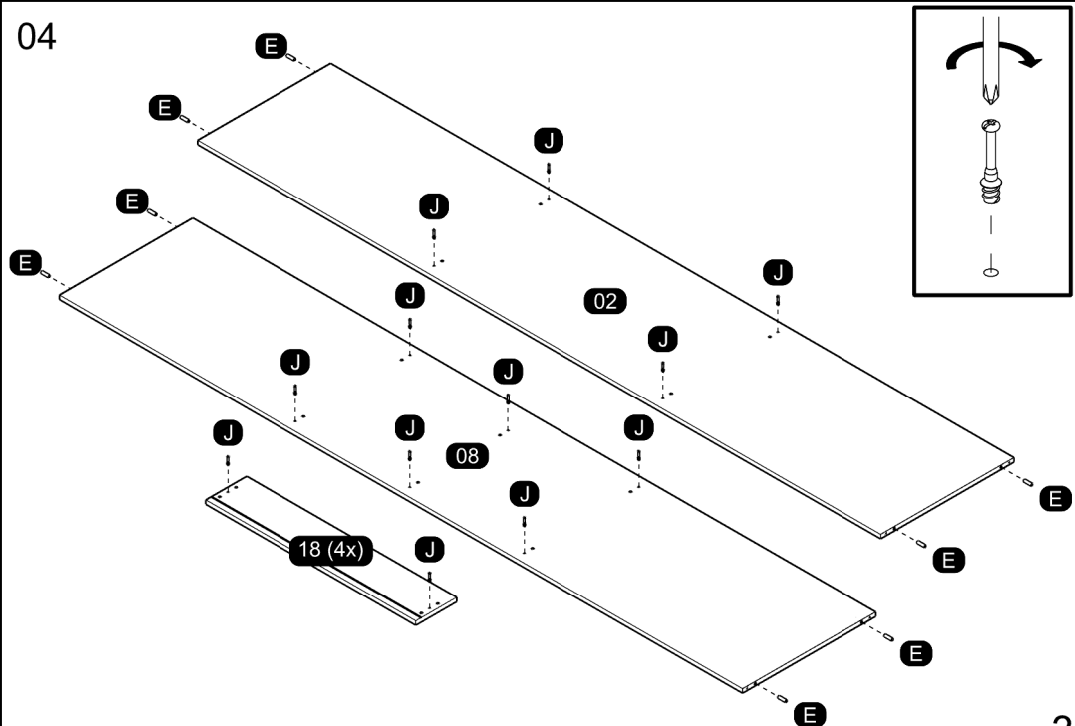

05

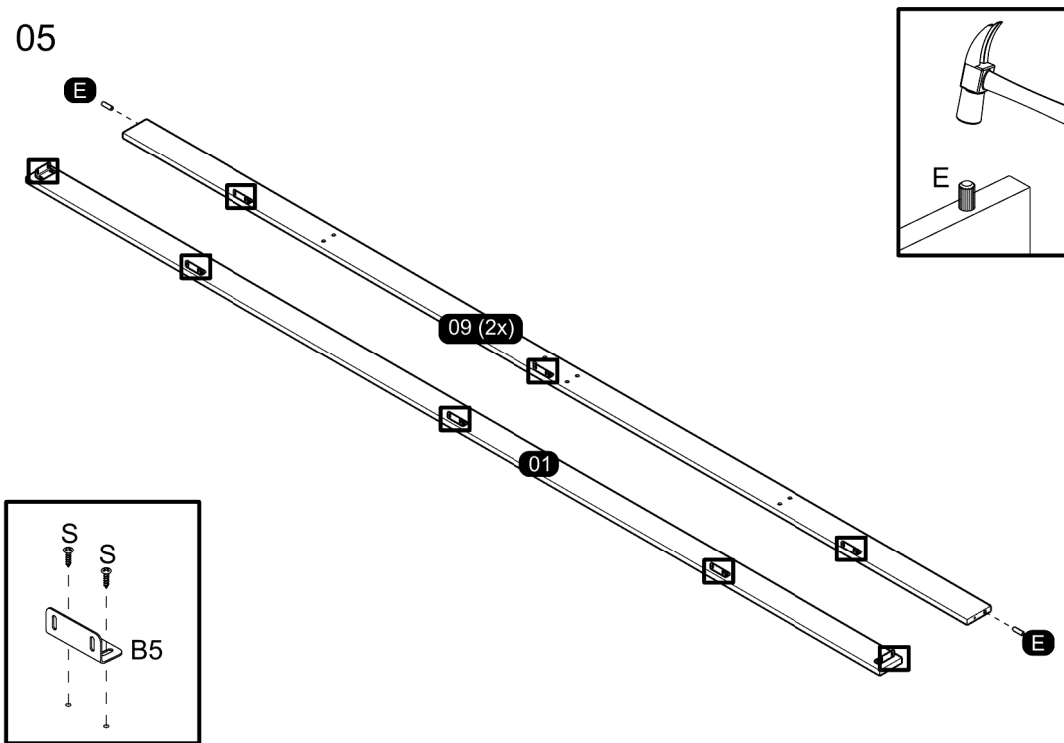

07

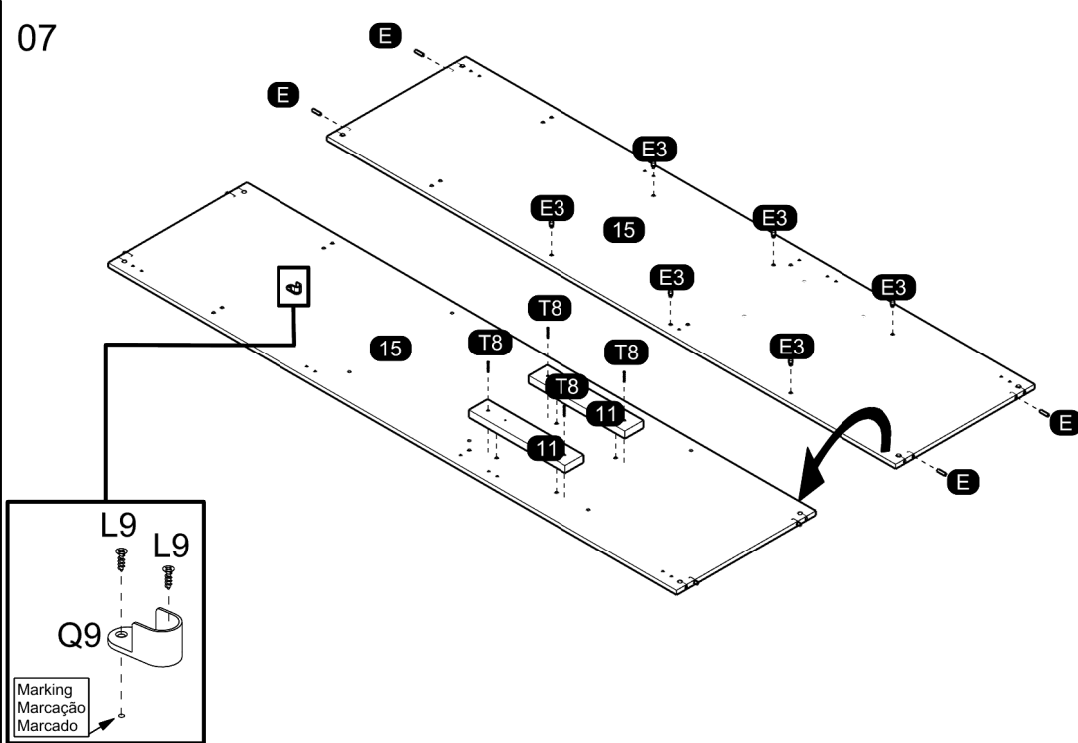

06

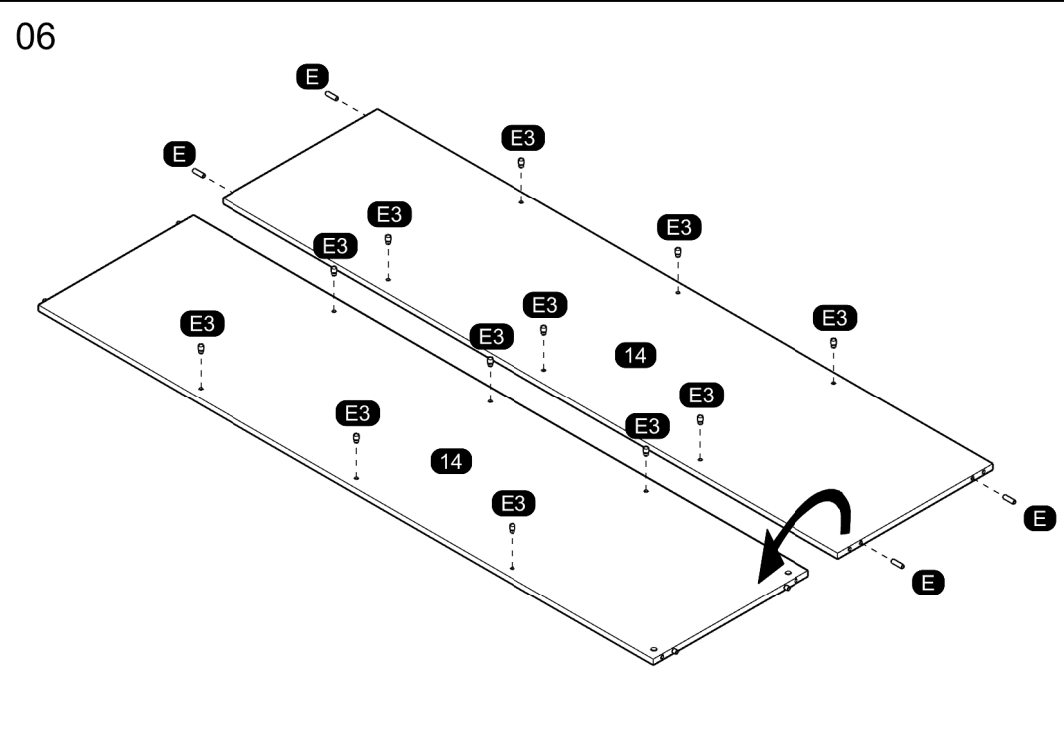

08

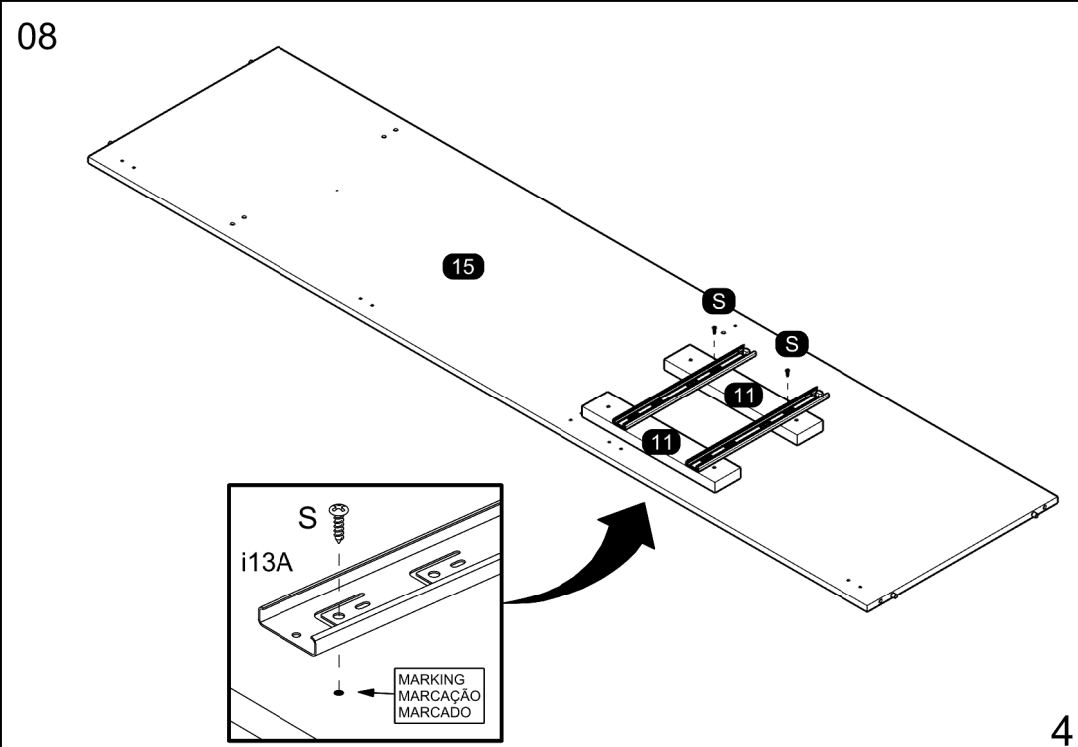

09

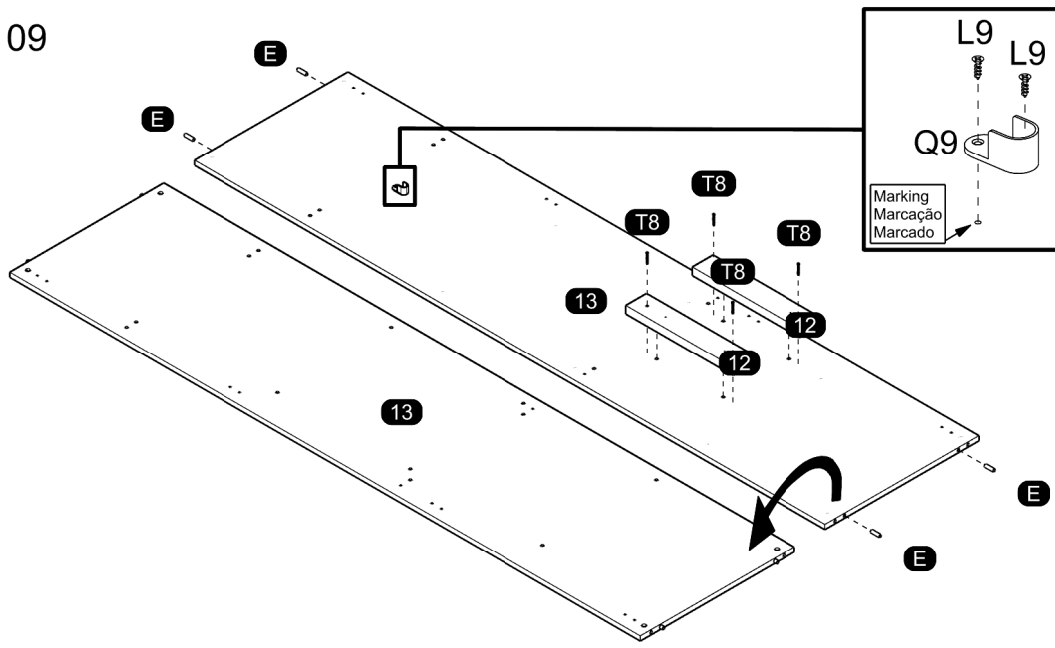

11

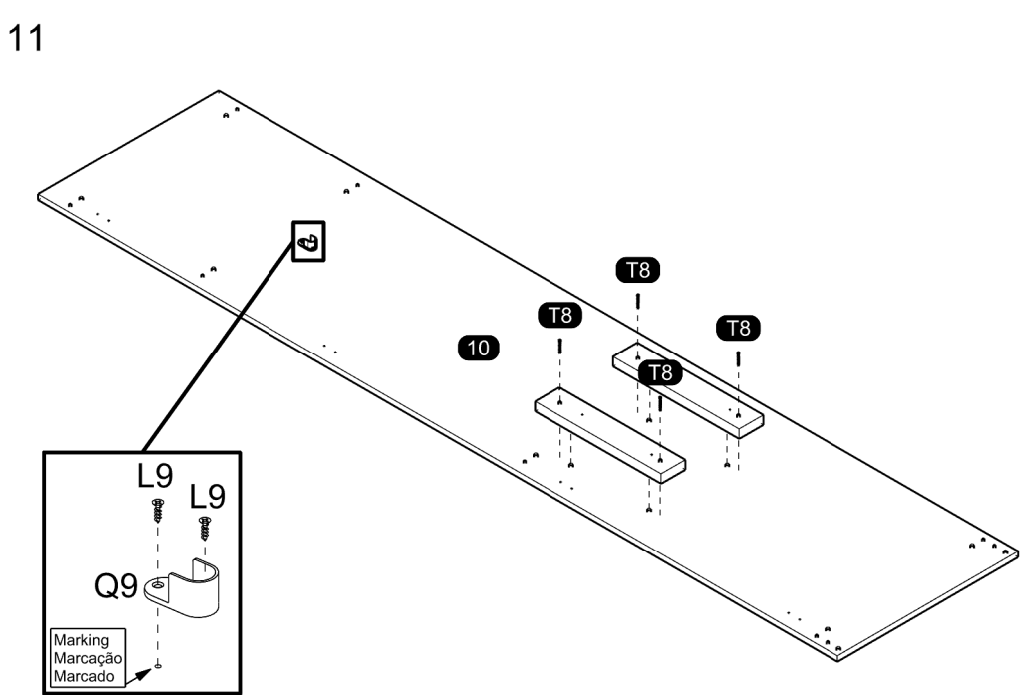

10

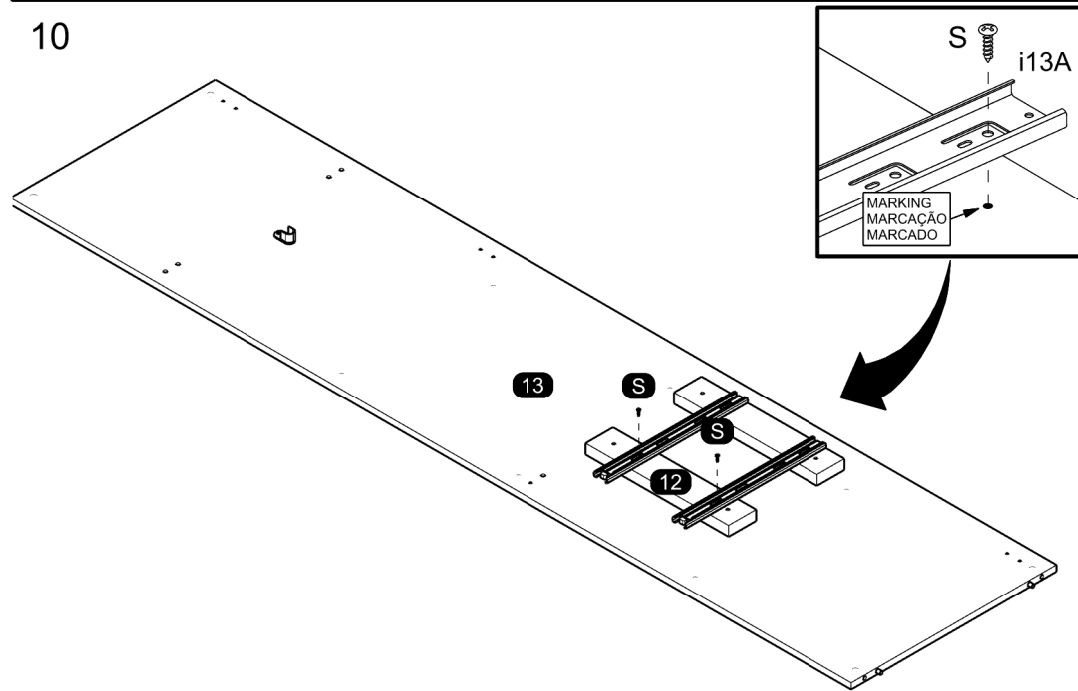

12

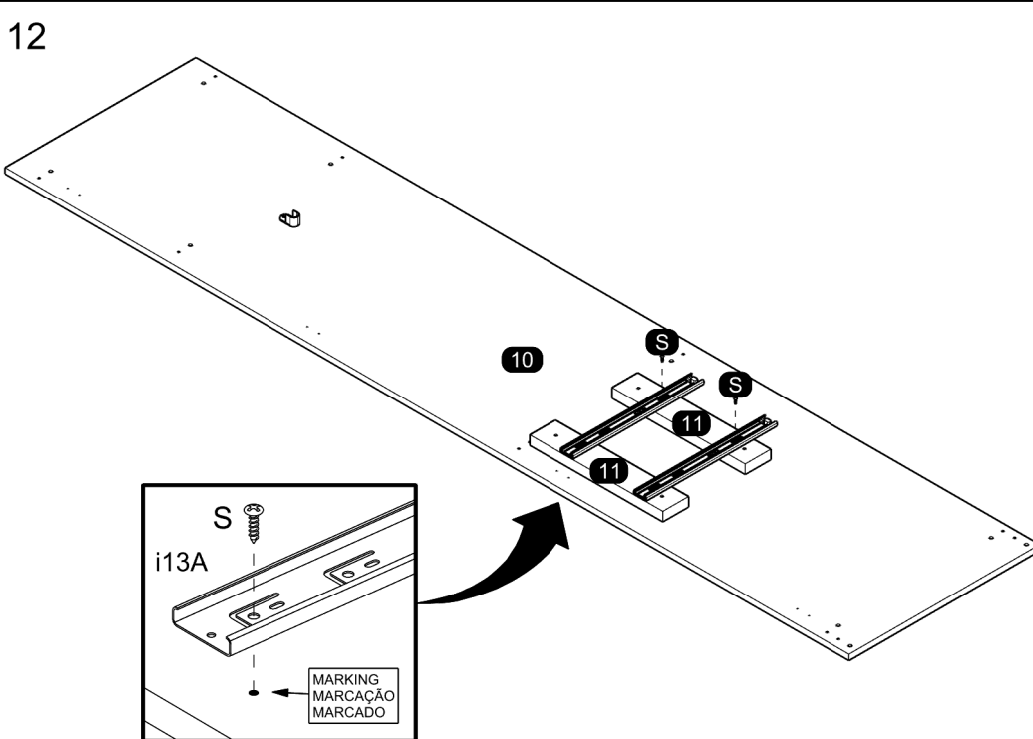

13

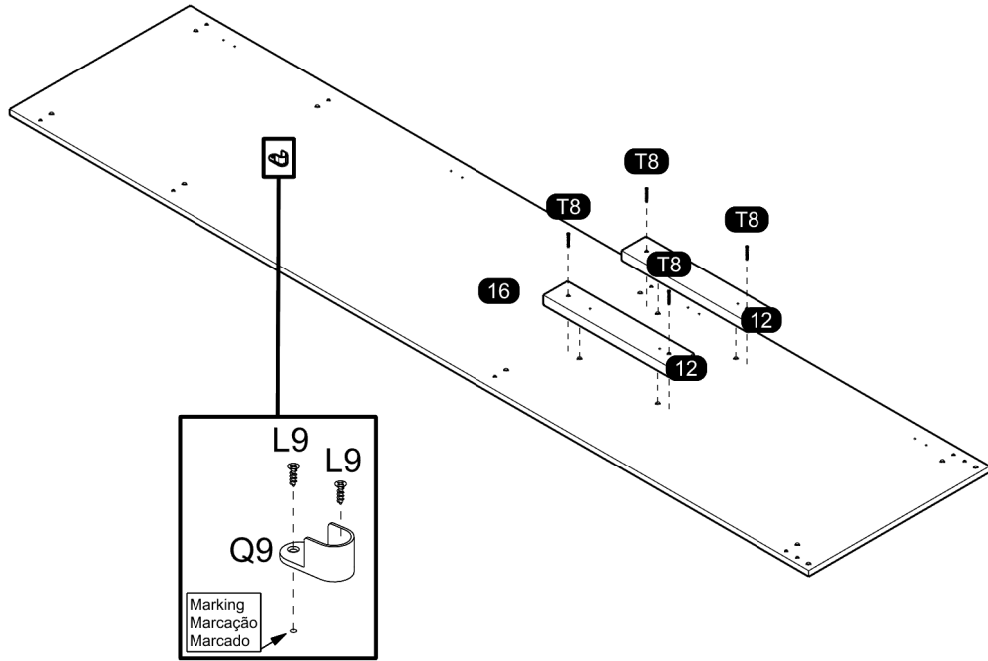

**ASSEMBLY  
MONTAGEM / ARMADO**

15

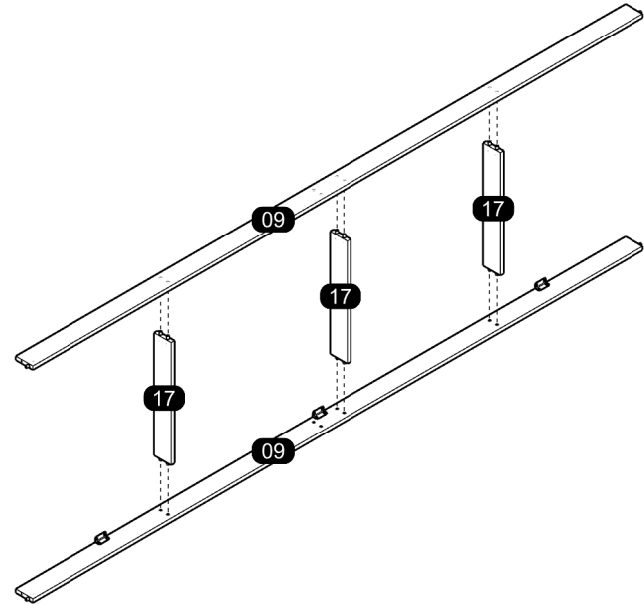

14

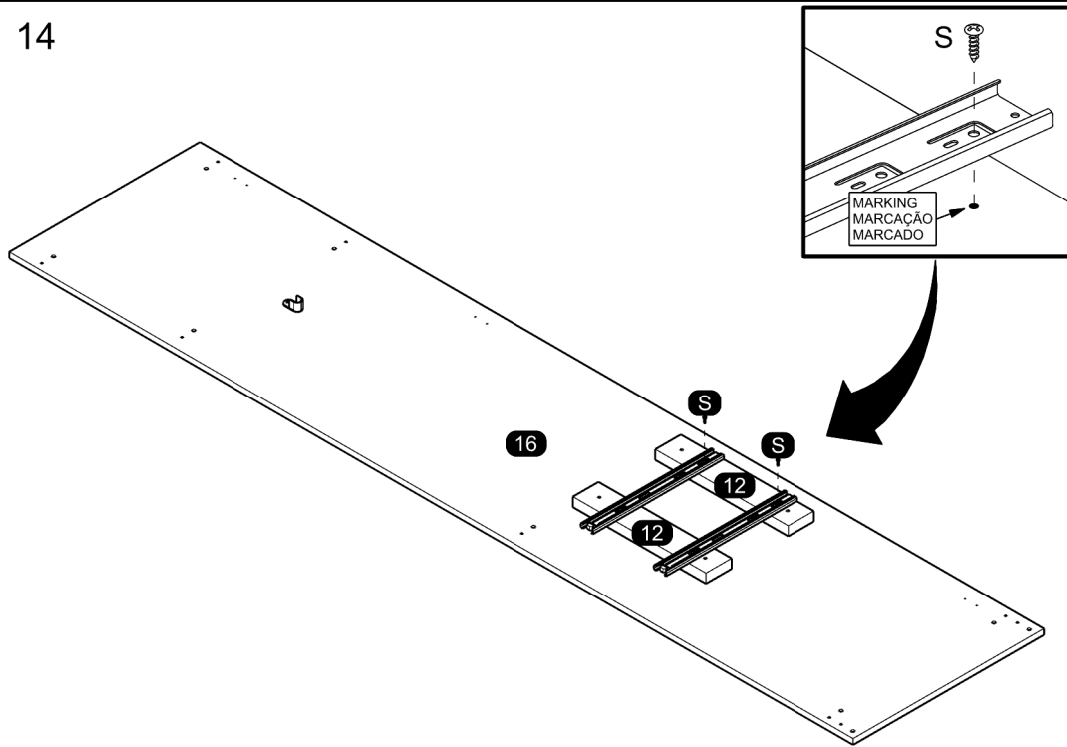

16

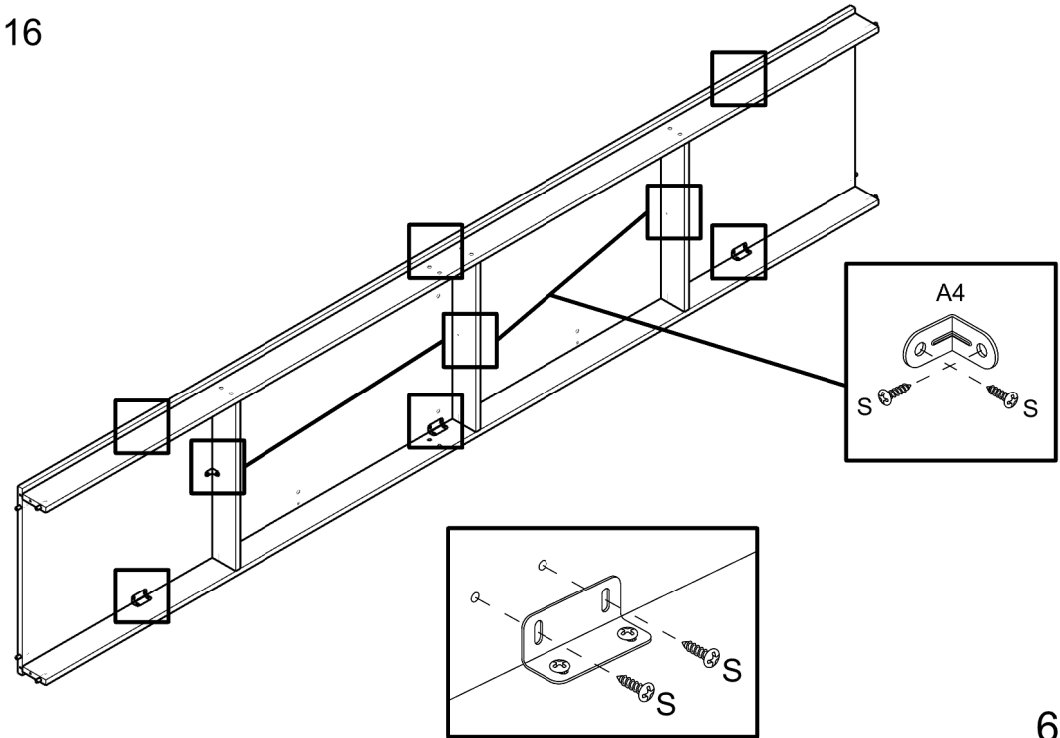

17

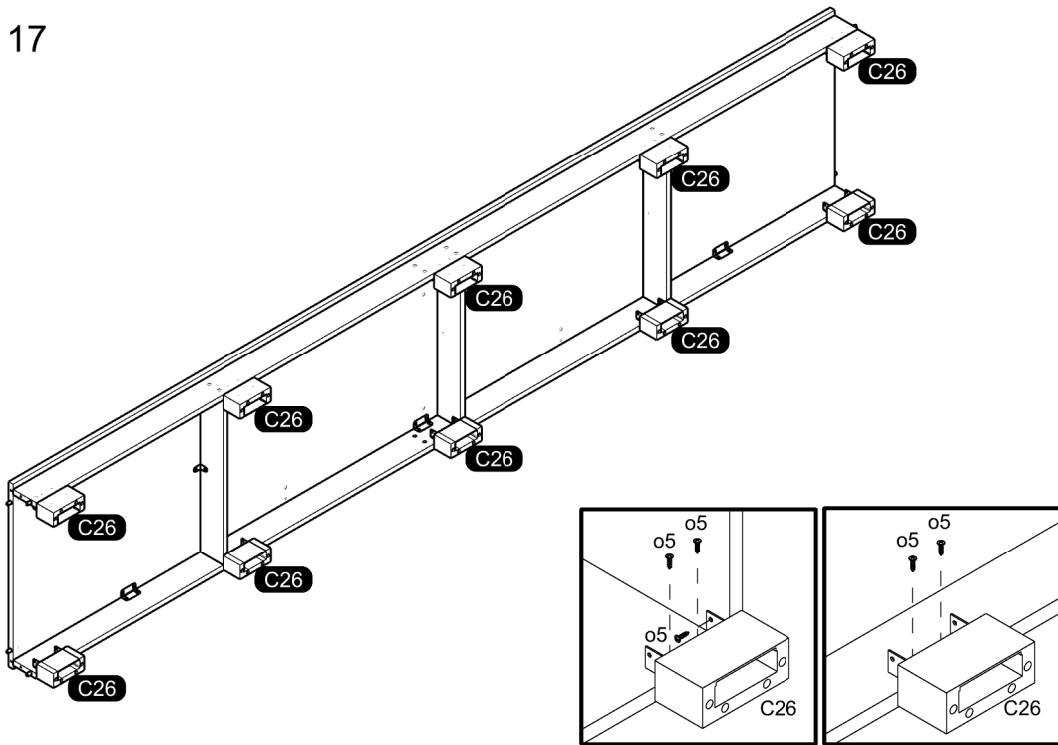

19

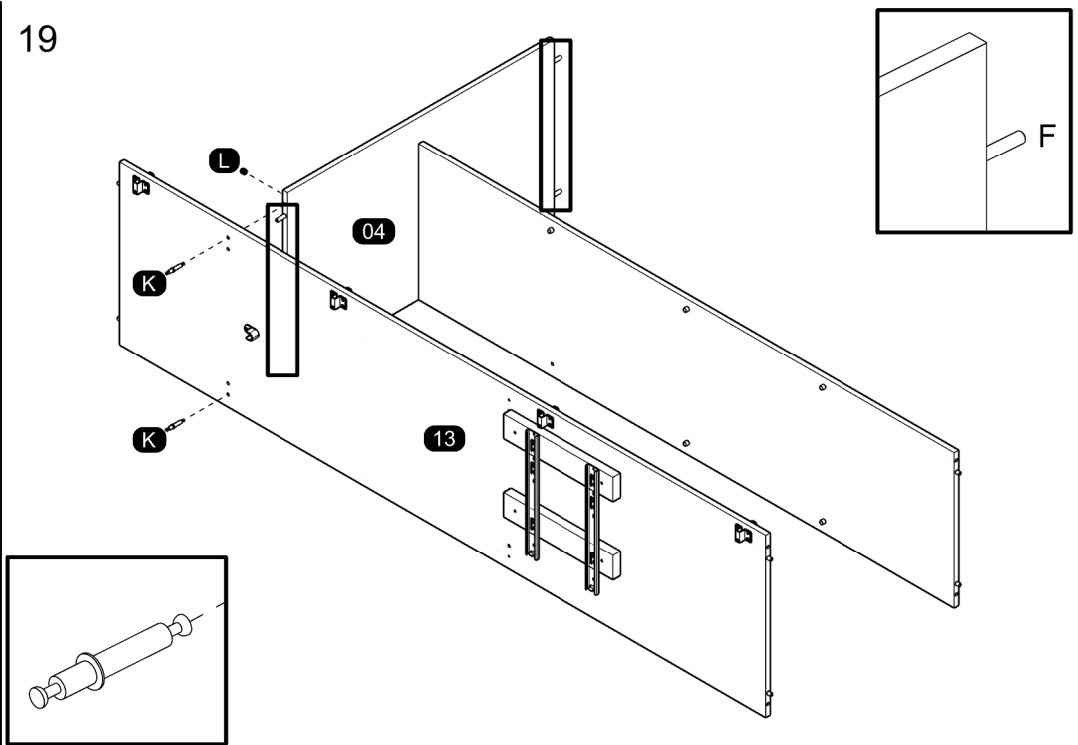

18

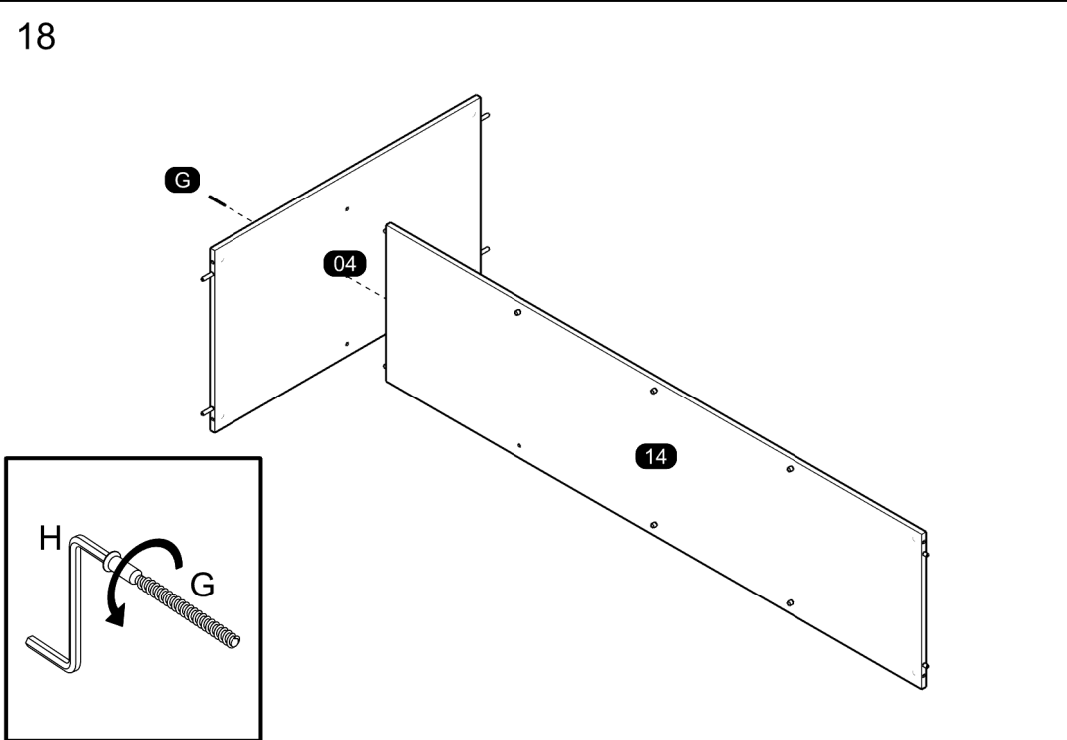

20

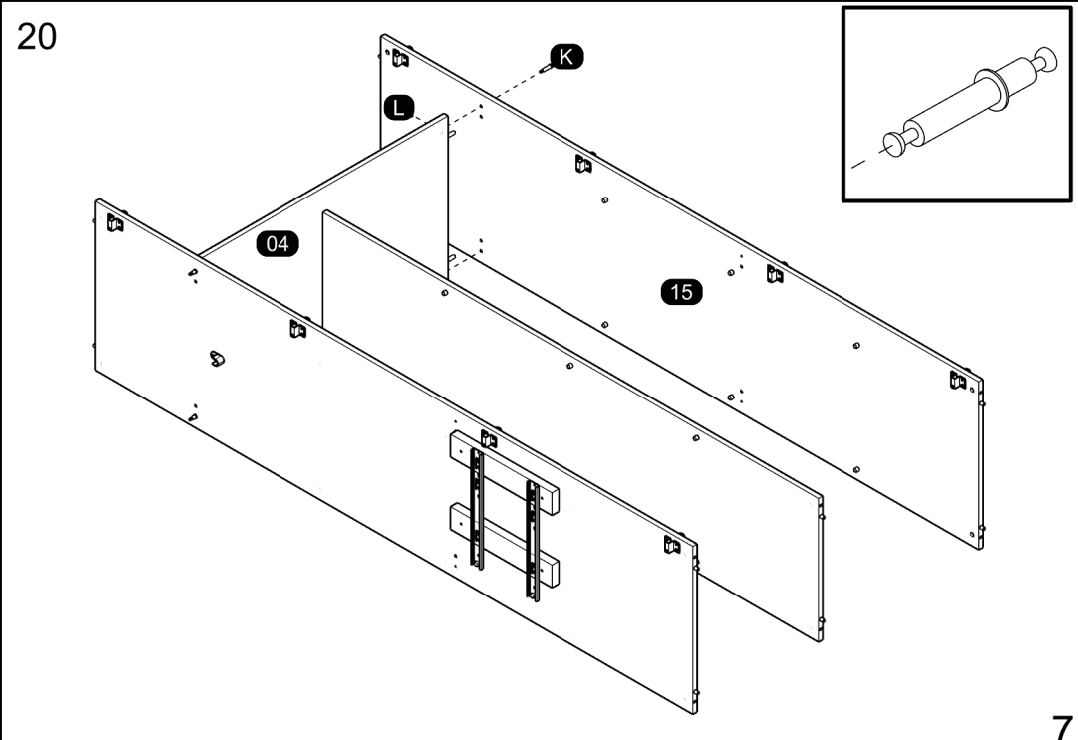

21

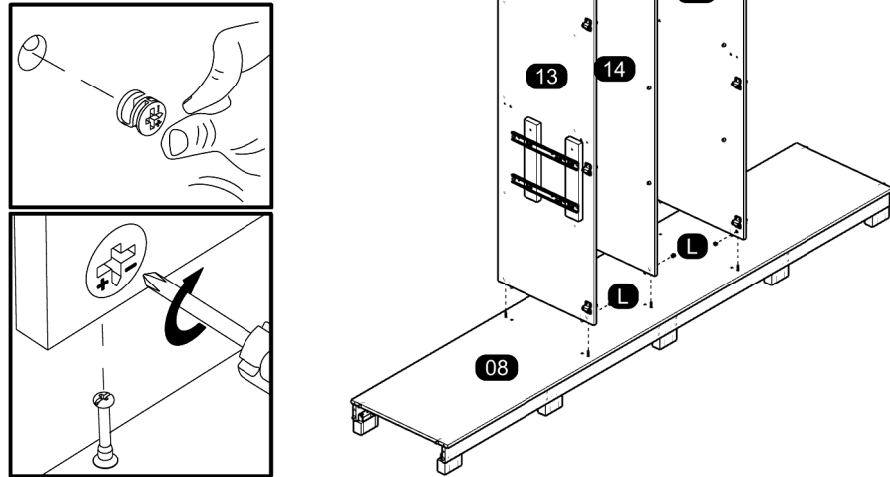

23

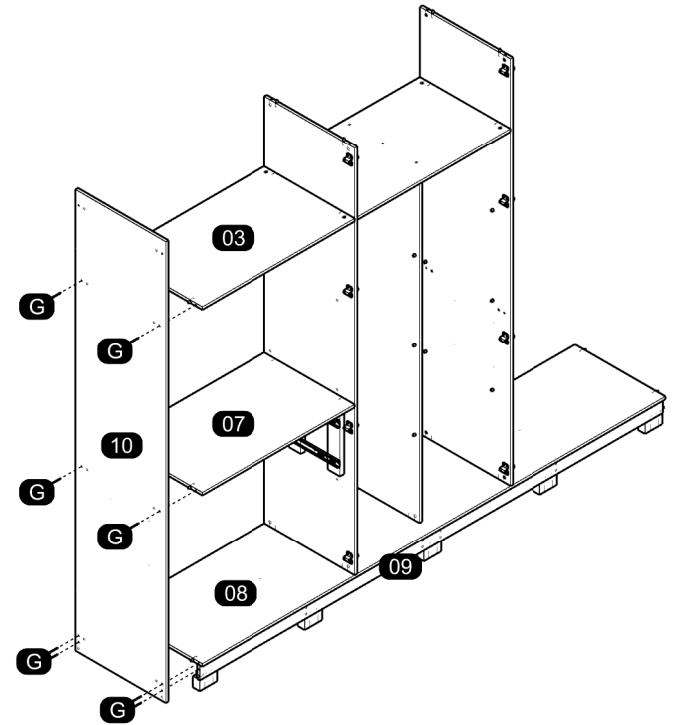
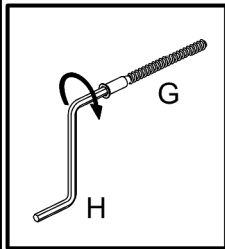

22

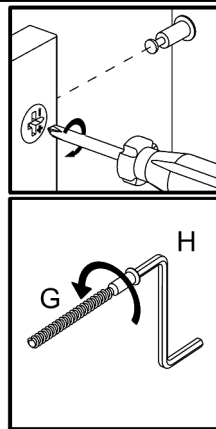
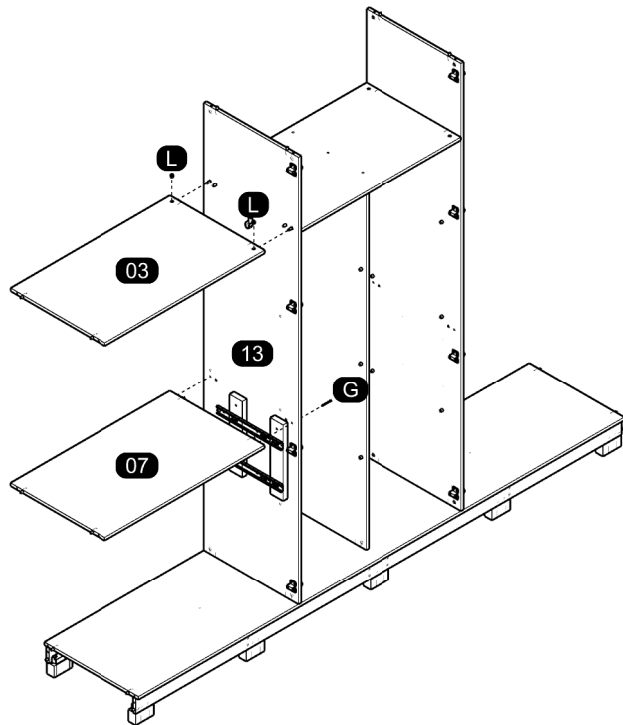

24

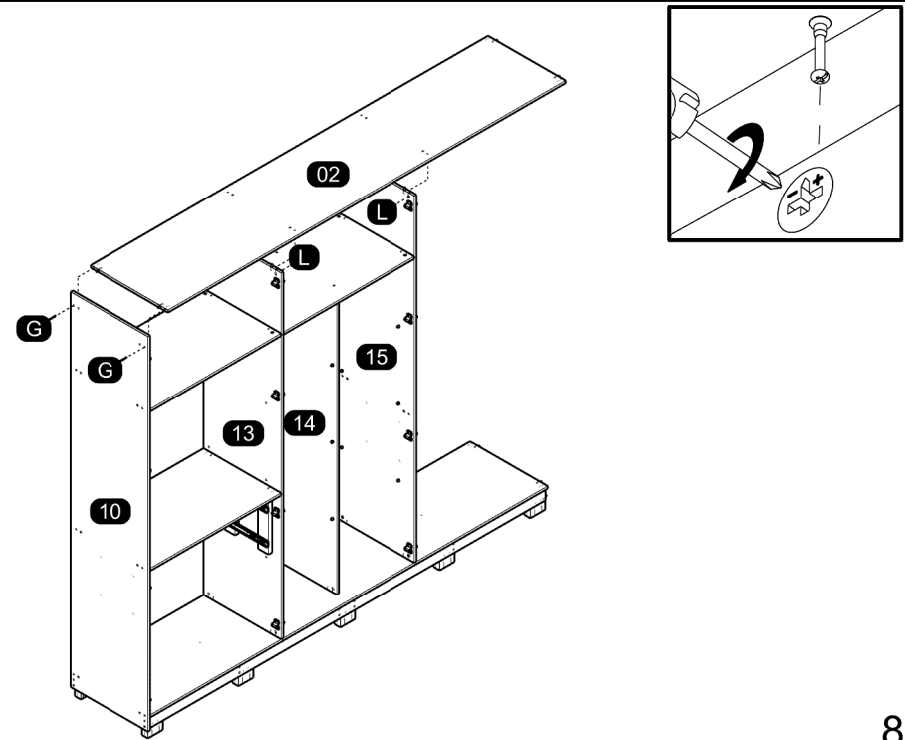

25

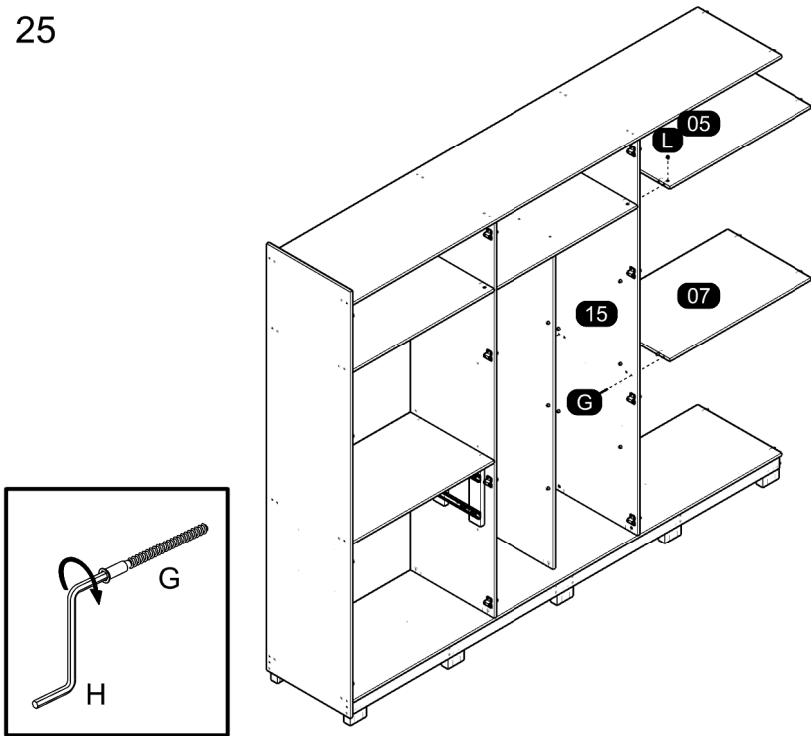

27

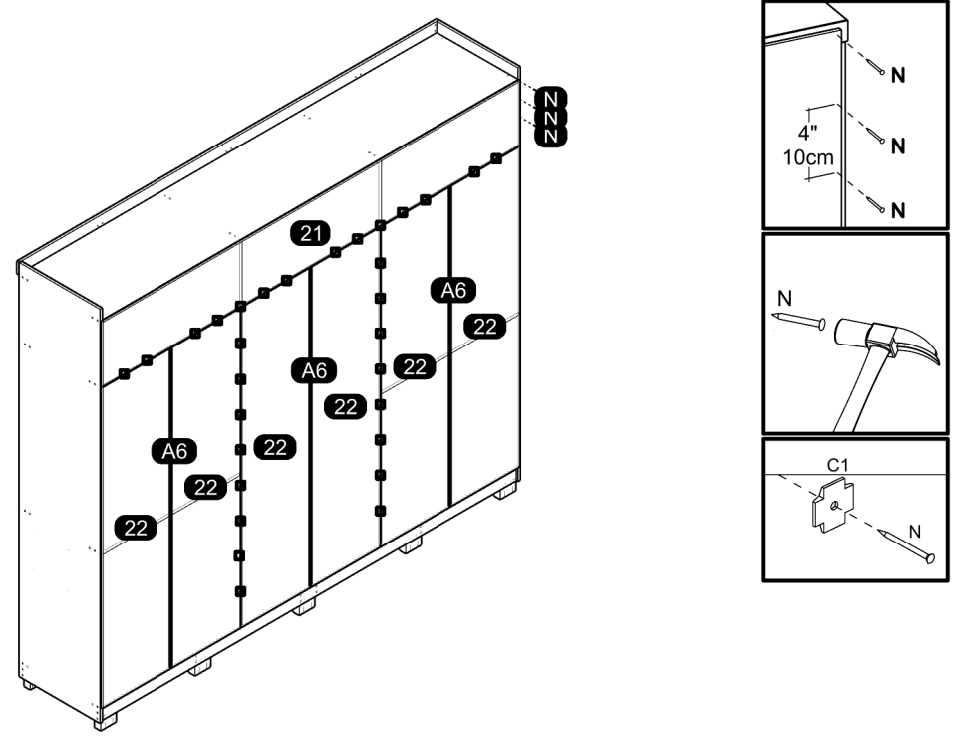

26

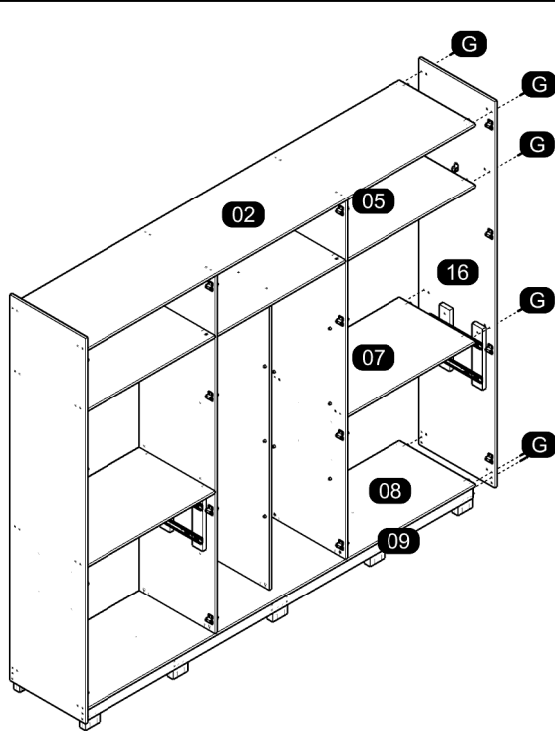

28

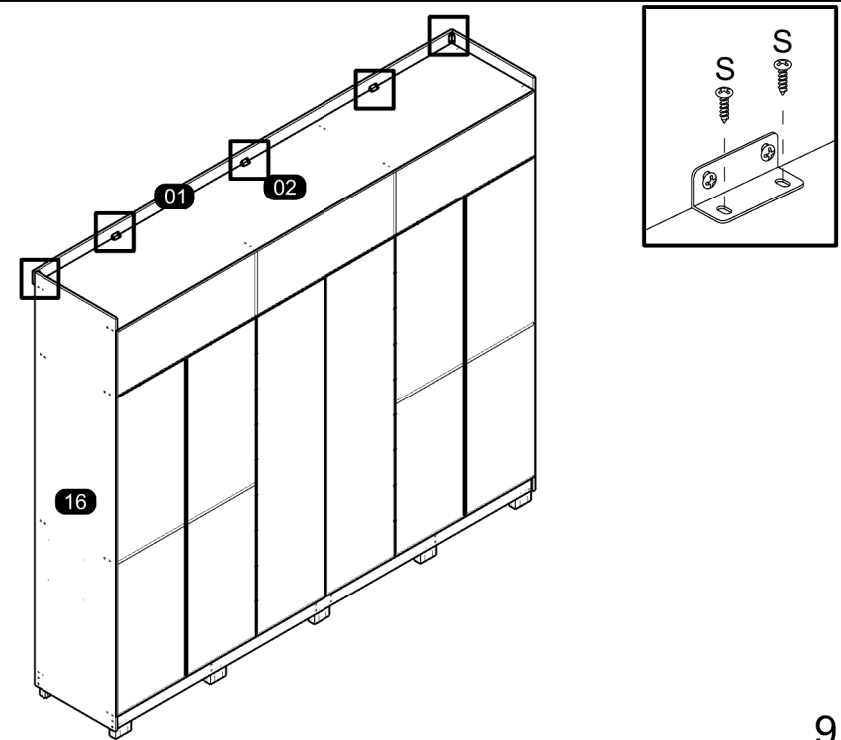

29

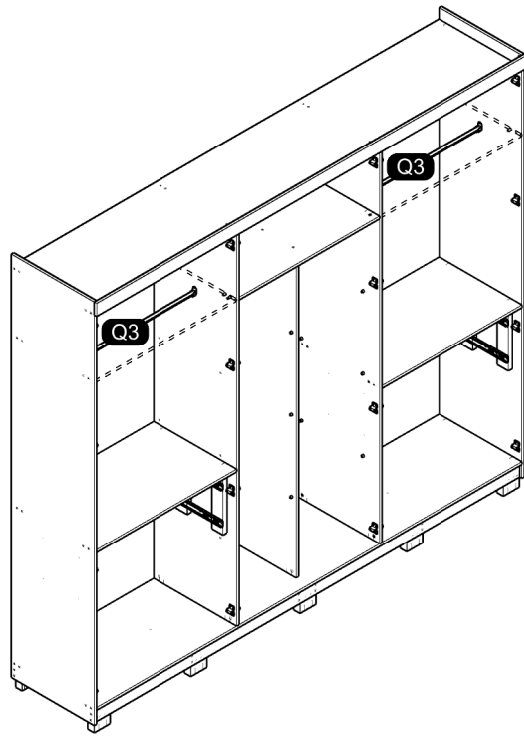
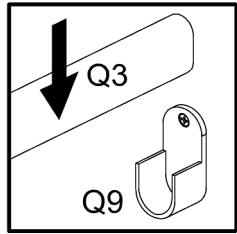

31

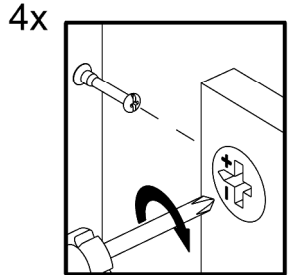
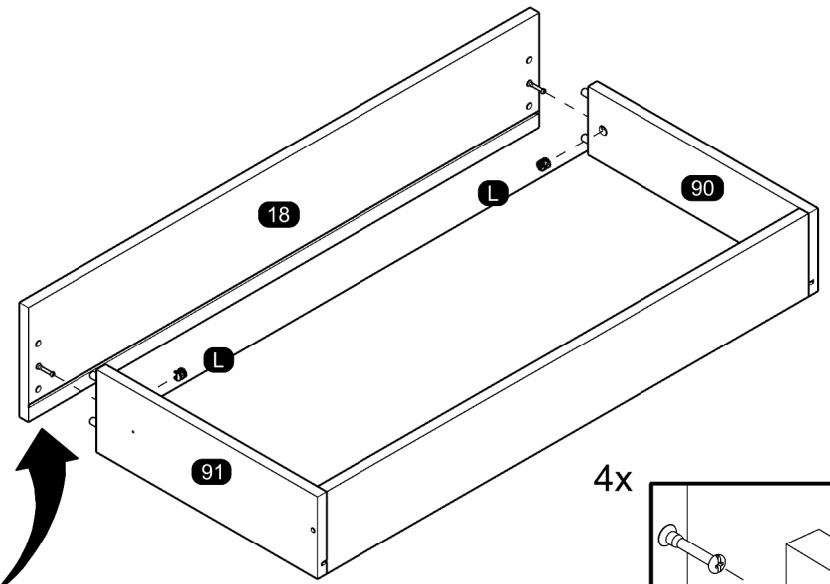
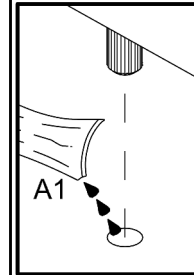

30

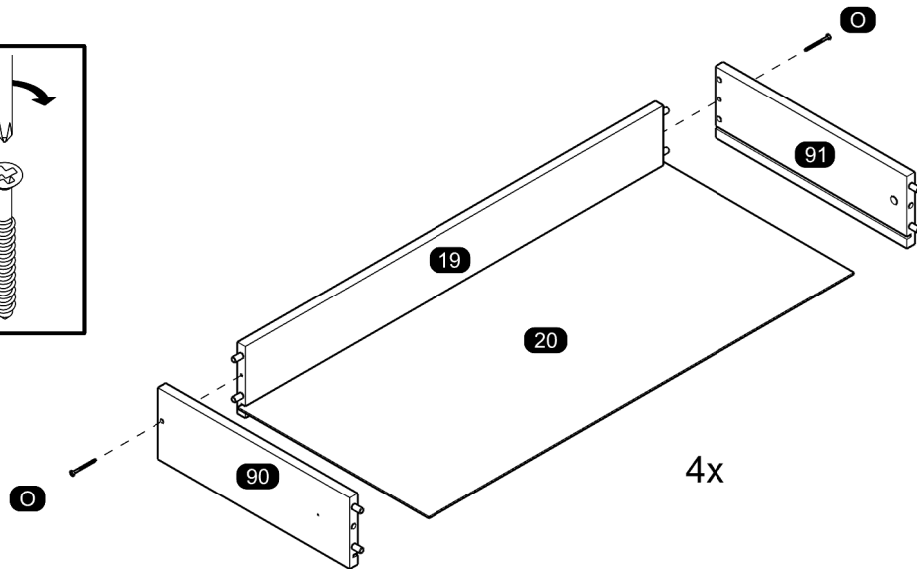
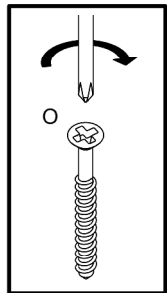

32

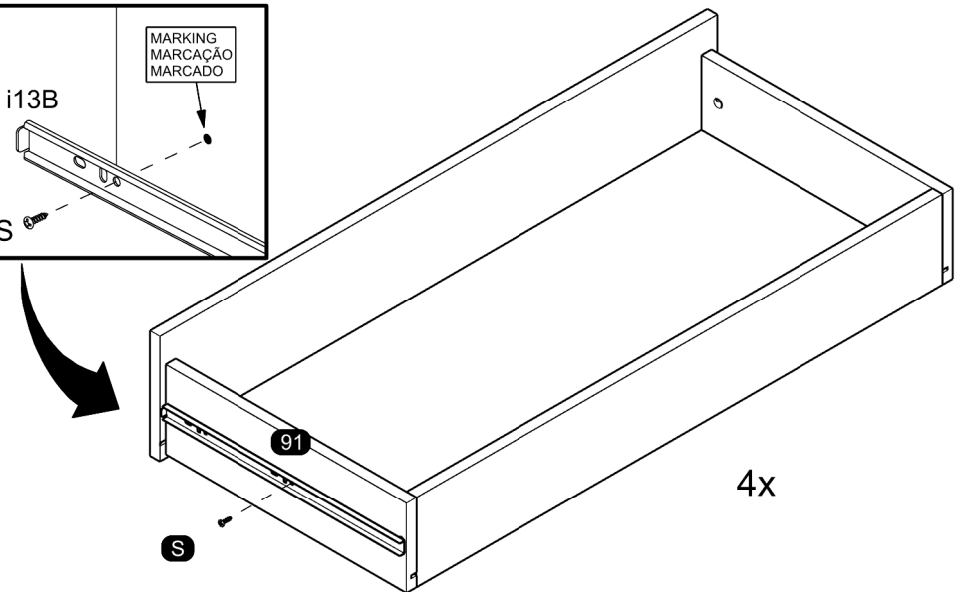
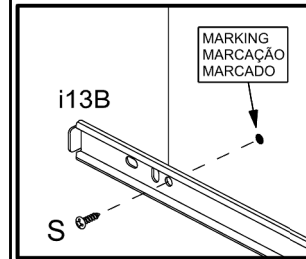

33

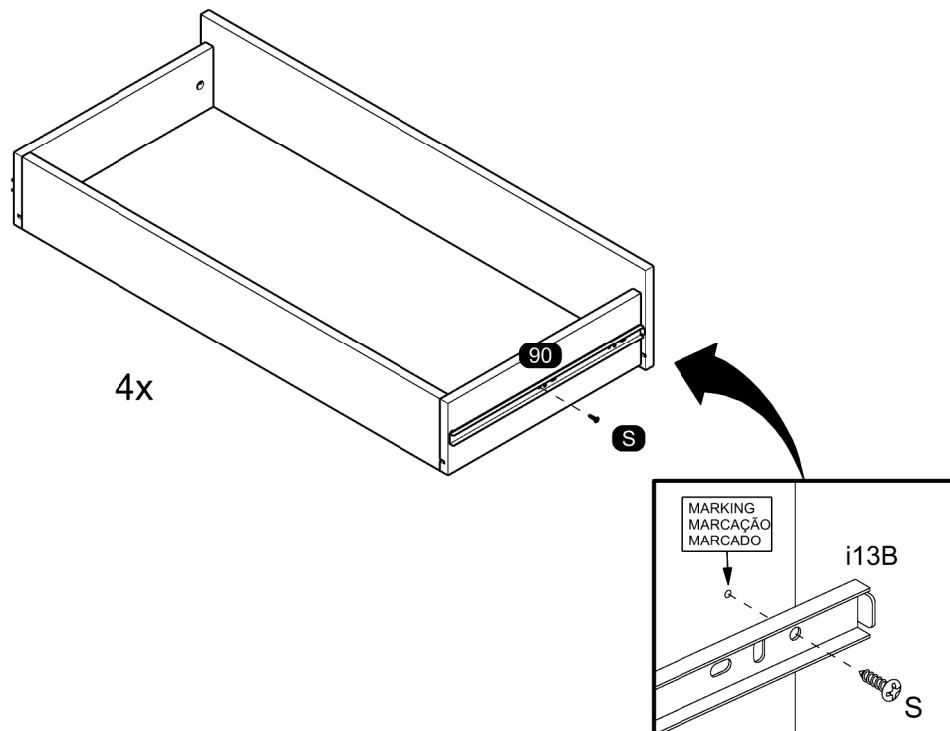

35

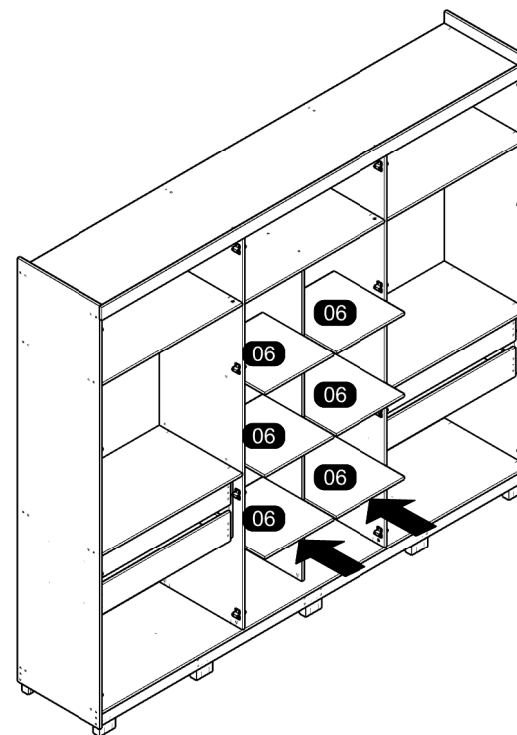

34

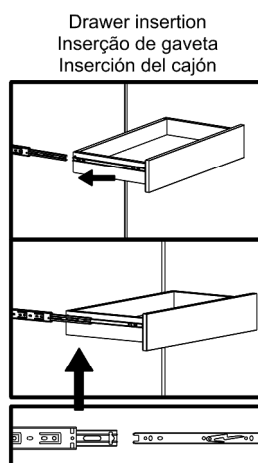
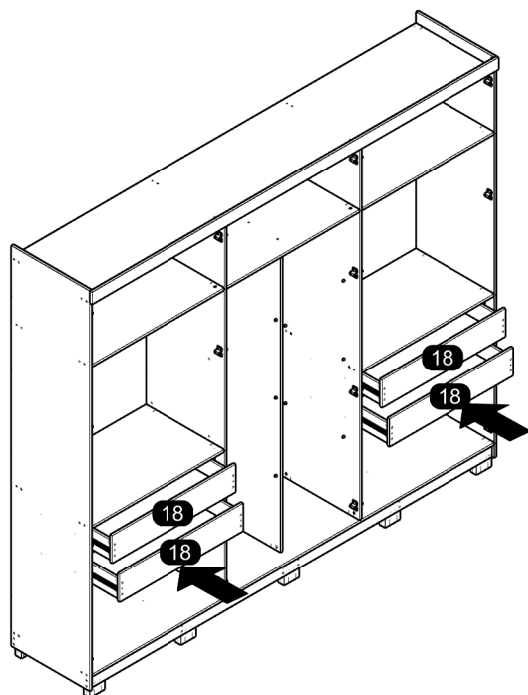

36

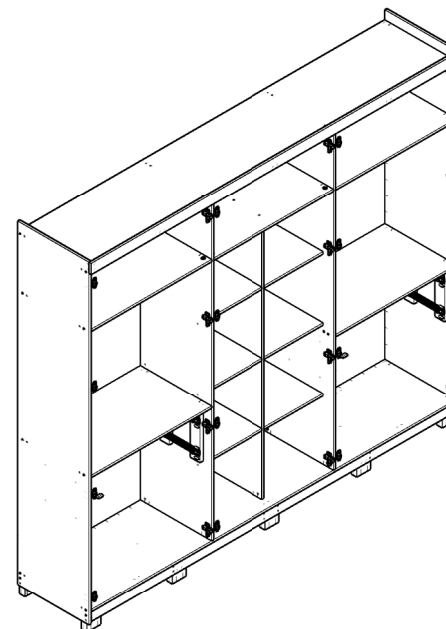

At the end of the assembly, insert the screw cover / hole plugs in the apparent holes.  
Ao final da montagem, insira a(s) tampa(s) de parafuso / tapa furos nos furos que ficarem aparentes.  
Al final del conjunto, coloque la tapa tornillo / tapón plástico en los agujeros que se hagan evidentes.

37

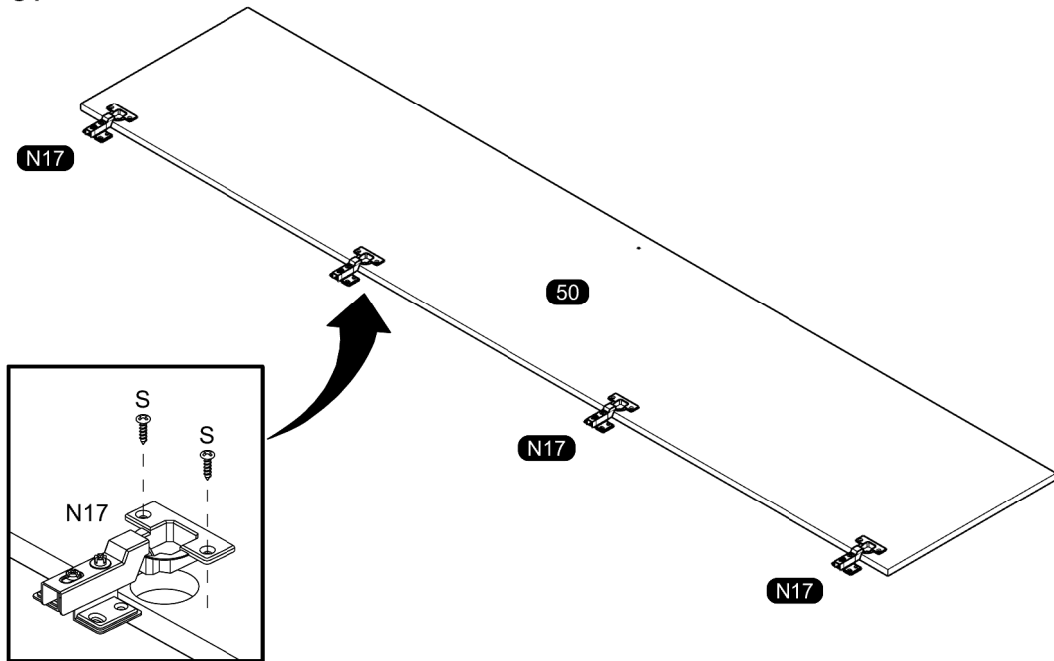

39

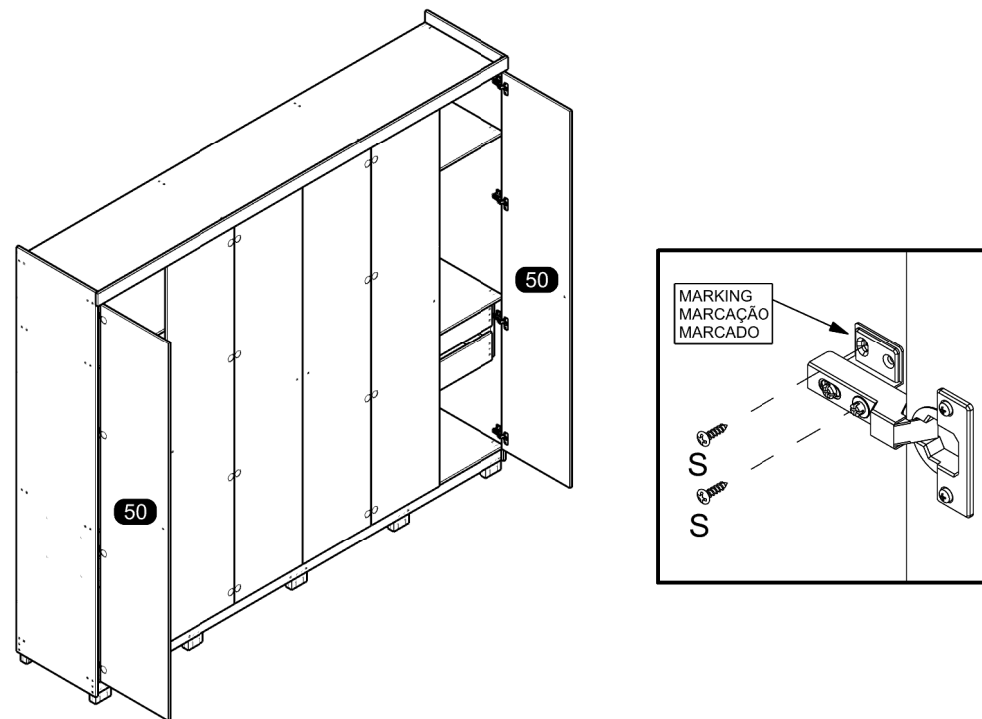

38

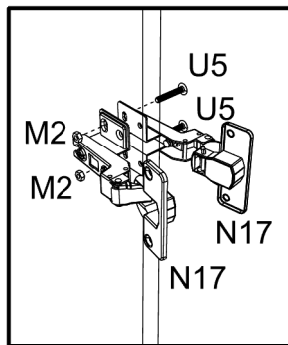
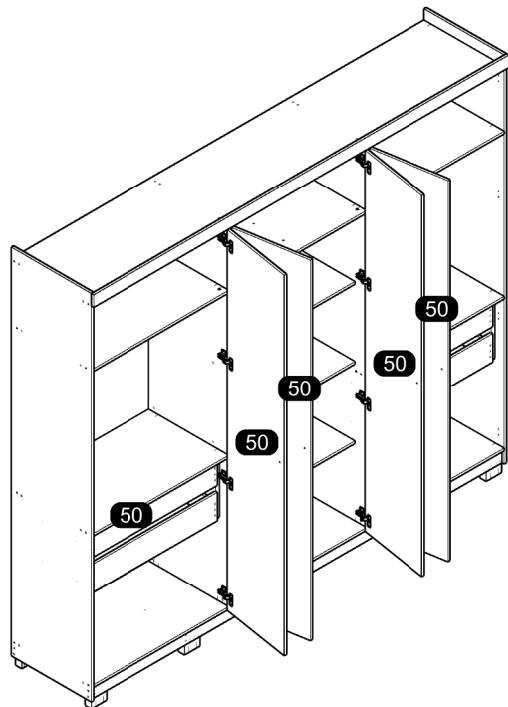

40

