

# ASSEMBLY INSTRUCTIONS MANUAL DE MONTAGEM / INSTRUCCIONES DE ARMADO

WARDROBE 4 DOORS  
ROUPEIRO 4P  
ROPERO 4 PUERTAS

Reference  
Referência  
Referencia **240936** | Revise  
| Revisão  
| Revisión **00**

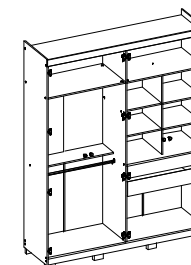

### YOU WILL NEED VOCÊ VAI PRECISAR DE / USTED NECESITARÁ

Tools not supplied  
Ferramentas não fornecidas / Herramientas no incluidas

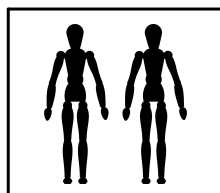

2 People  
2 Pessoas  
2 Personas

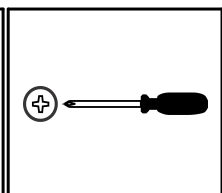

Screwdriver Phillips  
Chave Phillips  
Destornillador cruz

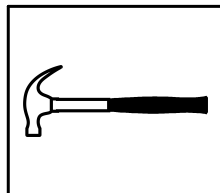

Hammer  
Martelo  
Martillo

### PARTS IDENTIFICATION IDENTIFICAÇÃO DAS PEÇAS / IDENTIFICACIÓN DE LAS PIEZAS

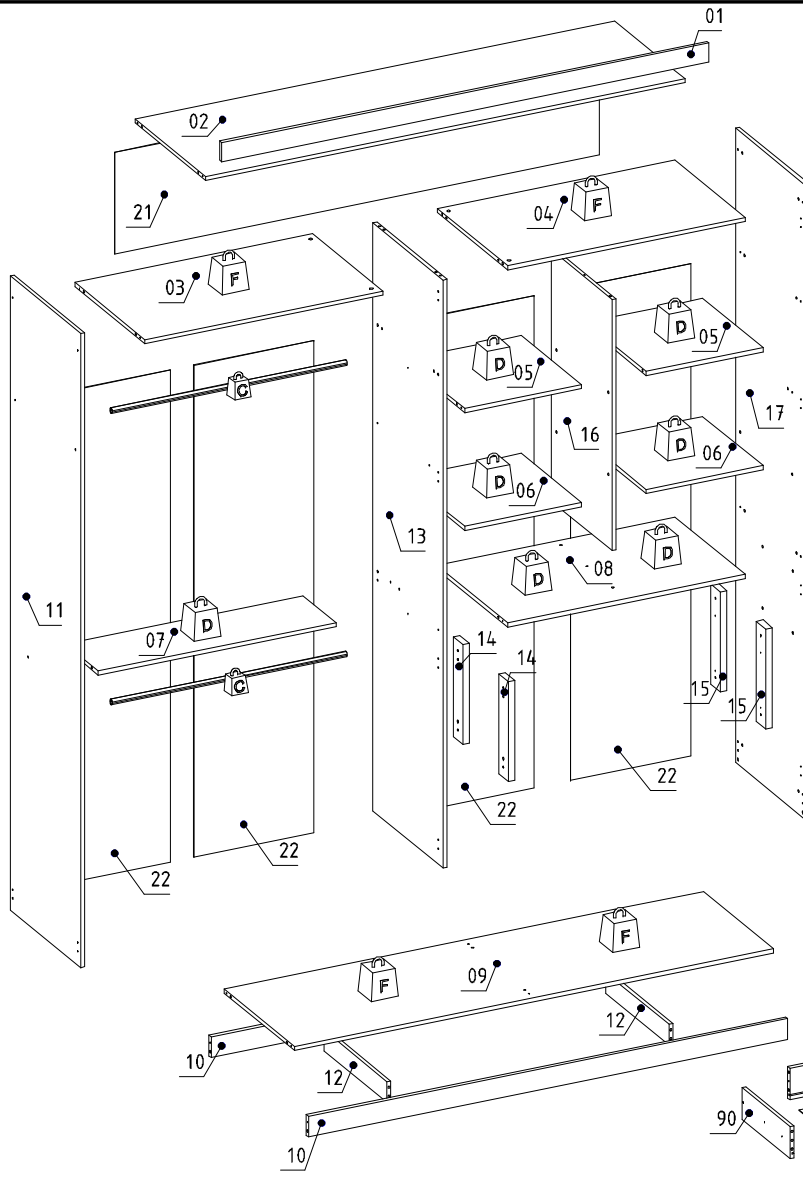

Nº	Measures_Inches	Medidas_cm	Qty./Qtd.
01	71 x 2 3/4 x 5/8	180.3 x 7.0 x 1.5	1
02	69 3/4 x 20 1/2 x 5/8	177.3 x 52.0 x 1.5	1
03	34 5/8 x 20 1/2 x 5/8	87.9 x 52.0 x 1.5	1
04	34 5/8 x 20 1/2 x 5/8	87.9 x 52.0 x 1.5	1
05	17 x 17 1/2 x 5/8	43.2 x 44.5 x 1.5	2
06	17 x 17 1/2 x 5/8	43.2 x 44.5 x 1.5	2
07	34 5/8 x 9 5/8 x 5/8	87.9 x 24.3 x 1.5	1
08	34 5/8 x 20 1/2 x 5/8	87.9 x 52.0 x 1.5	1
09	69 3/4 x 20 1/2 x 5/8	177.3 x 52.0 x 1.5	1
10	69 3/4 x 3 x 5/8	177.3 x 7.5 x 1.5	2
11	90 1/2 x 20 1/2 x 5/8	230.0 x 52.0 x 1.5	1
12	18 1/4 x 3 x 5/8	46.5 x 7.5 x 1.5	2
13	83 7/8 x 20 1/2 x 5/8	213.2 x 52.0 x 1.5	1
14	14 1/4 x 2 3/4 x 1	36.2 x 7.0 x 2.5	2
15	14 1/4 x 2 3/4 x 1	36.2 x 7.0 x 2.5	2
16	35 7/8 x 17 1/2 x 5/8	91.0 x 44.5 x 1.5	1
17	90 1/2 x 20 1/2 x 5/8	230.0 x 52.0 x 1.5	1
18	6 1/4 x 32 3/8 x 5/8	16.0 x 82.1 x 1.5	1
18	32 3/8 x 6 1/4 x 5/8	82.1 x 16.0 x 1.5	1
19	30 1/2 x 4 1/2 x 5/8	77.4 x 11.5 x 1.5	2
20	31 x 13 7/8 x 1/8	78.8 x 35.4 x 0.3	2
21	70 5/8 x 14 1/2 x 1/8	179.3 x 36.7 x 0.3	1
22	70 1/4 x 17 1/2 x 1/8	178.4 x 44.4 x 0.3	4
90	14 x 4 1/2 x 5/8	35.5 x 11.5 x 1.5	2
91	14 x 4 1/2 x 5/8	35.5 x 11.5 x 1.5	2

MAXIMUM RECOMMENDED WEIGHT  
BEING THIS EVENLY DISTRIBUTED.



PESO MÁXIMO RECOMENDADO SENDO  
ESTE DISTRIBUÍDO UNIFORMEMENTE.

PESO MÁXIMO RECOMENDADO SIENDO  
ESTE UNIFORMEMENTE DISTRIBUIDO.

	LB	KG
—		
C	6	3
D	11	5
F	22	10

# IDENTIFICATION OF ACCESSORIES

## IDENTIFICAÇÃO DOS ACESSÓRIOS/ IDENTIFICACIÓN DE ACCESORIOS



The separation of the accessories before you start the assembly will facilitate the same. In case of doubt on the size of the screws and bolts, use the ruler to bottom of page.

A separação dos acessórios antes de iniciar a montagem facilitará a mesma. Em caso de dúvida no tamanho dos parafusos e cavilhas, utilize a régua ao final da página.

La separación de los accesorios antes de comenzar el armado facilitará el mismo. En caso de duda sobre el tamaño de los tornillos y taquetes, utilice la regla al pie de página.

A1		Glue Cola / Pegamento	13 g	1
A4		Metalic bracket Cantoneira de metal / Suporte de metal	22x22 mm	2
A6		"H" profile Perfil "H" / Perfil "H"	-	2
B5		Metalic angle plates Cantoneira de metal / Suporte de metal	46 mm	8
C1		Metal claw Garra de metal / Garra metal	-	17
C26		Foot Pé Atenas / Pie	55x40x100mm	8
E		Wooden dowel Cavilha / Taquete	8x30 mm	60
E3		Shelf bracket Suporte de prateleira / Suporte de repisa	8x7 mm	8
F		Wooden dowel Cavilha / Taquete	8x50 mm	4
G		Structural screw Parafuso estrutural / Tornillo estructural	5,0x50	28
H		Allen key Chave allen / Liave allen	3 mm	2
H27		Handle Puxador Italia / Tirador	-	4
I		Structural screw cover Tampa parafuso estrutural / Tapa tornillo estructural	-	26
i13		Telescopic slide Corrediça telescópica / Corredera telescópica	350 mm	4
J		Simple minifix screw Haste minifix simples / Tornillo minifix simple	-	8
K		Double minifix screw Haste minifix dupla / Tornillo minifix doble	60mm	2
L		Drum lock Tambor minifix / Tambor minifix	12 mm	12
M		Bore patch adhesive Tapa furo adesivo / Tapones adhesivo	-	12
M2		Nut Porca / Tuerca	4 mm	8
N		Nail Prego / Clavo	10x10	104
N7		Wooden dowel Cavilha / Taquete	8x20 mm	8
N17		Metal hinge straight Dobradiça curva / Bisagra recta	35 mm	24
O		Flat head screw Parafuso chato / Tornillo de cabeza plana	4,5x45 mm	4
o5		Flanged head screw Parafuso flangeado / Tornillo de cabeza flangeada	3,5x14 mm	20
Q3		Clothes rack Cabideiro tubo / Perchero	-	2

Q9		Clothes rack support Suporte cabideiro / Soporte perchero	-	4
S		Pan head screw Parafuso panela / Tornillo de pan	3,5x14 mm	132
T		Flanged head screw Parafuso flangeado / Tornillo de cabeza flangeada	3,5x25 mm	4
T8		Flat head screw Parafuso chato / Tornillo de cabeza plana	3,5x35 mm	8
U5		Flat head screw Flat head screw / Flat head screw	4,0x25 mm	8

SEPARATE THE TWO PARTS OF THE METAL SLIDE TO THE ASSEMBLY FOLLOWING THE INSTRUCTIONS BELOW.  
SEPARAR AS DUAS PARTES DA CORREDIÇA METÁLICA PARA A MONTAGEM SEGUINDO AS INSTRUÇÕES ABAIXO.  
SEPARAR LAS DOS PARTES DE LA CORREDERA DE METAL PARA EL ARMADO Y SEGUIR A LAS INSTRUCCIONES ABAJO.

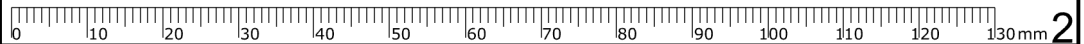
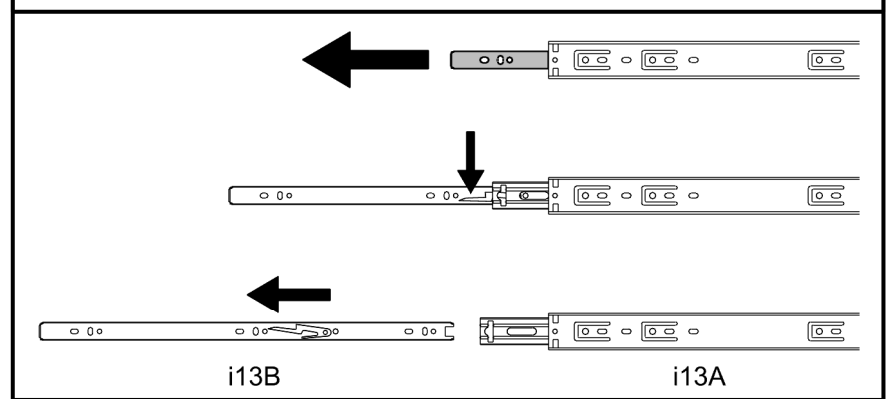

**PRE-ASSEMBLE  
PRÉ-MONTAGEM / PRE ARMADO**

01

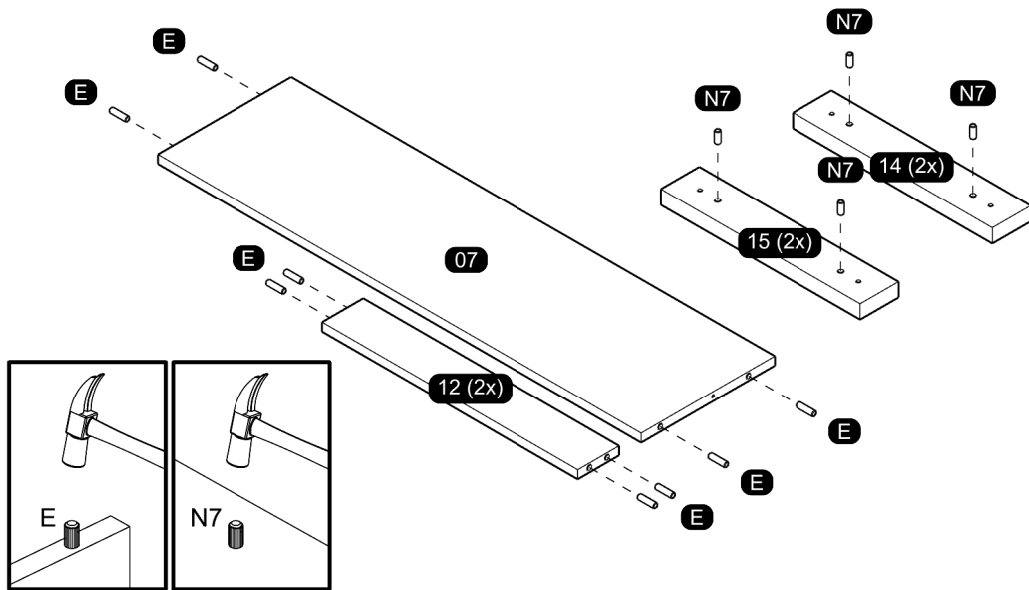

03

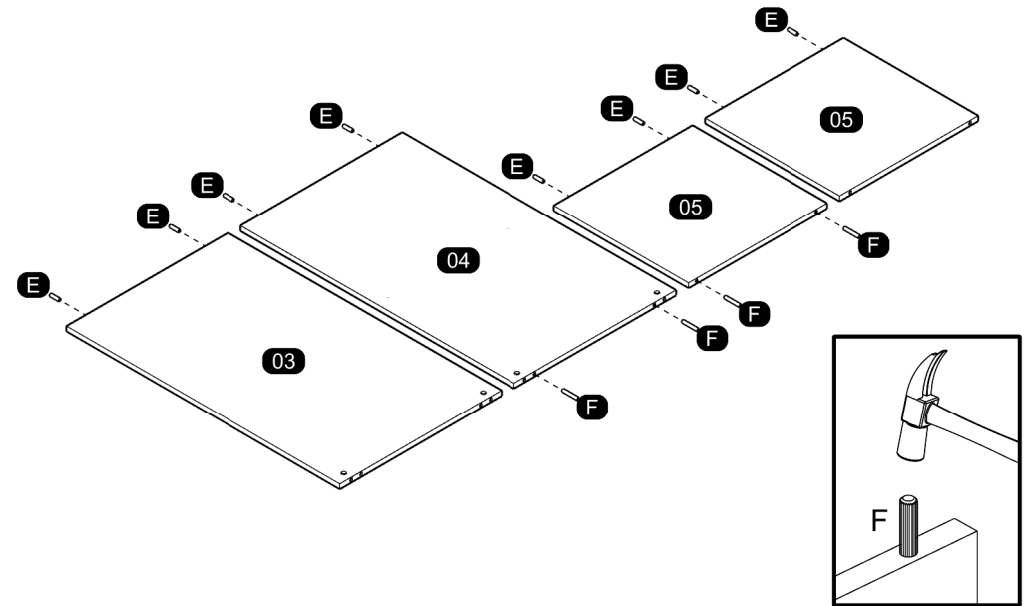

02

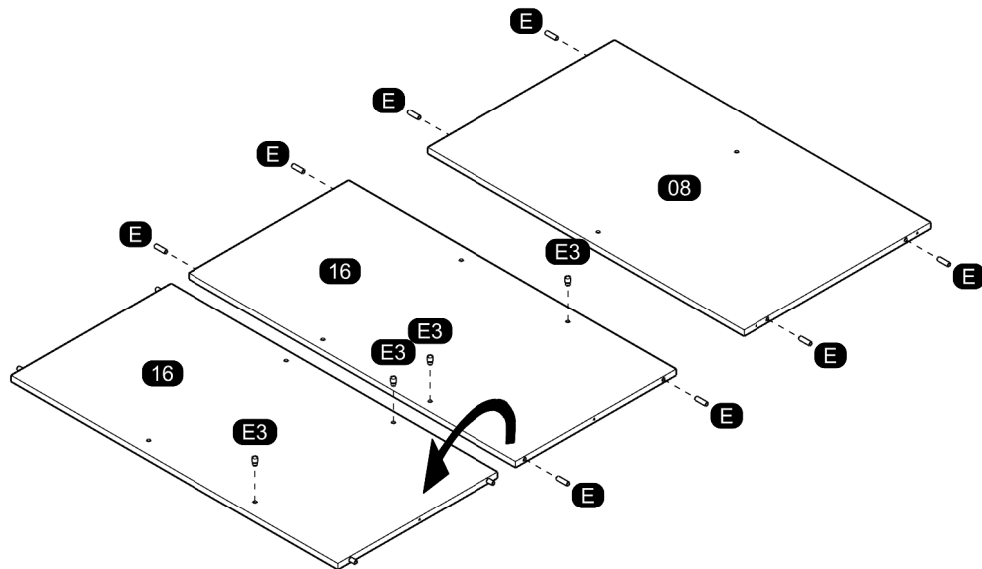

04

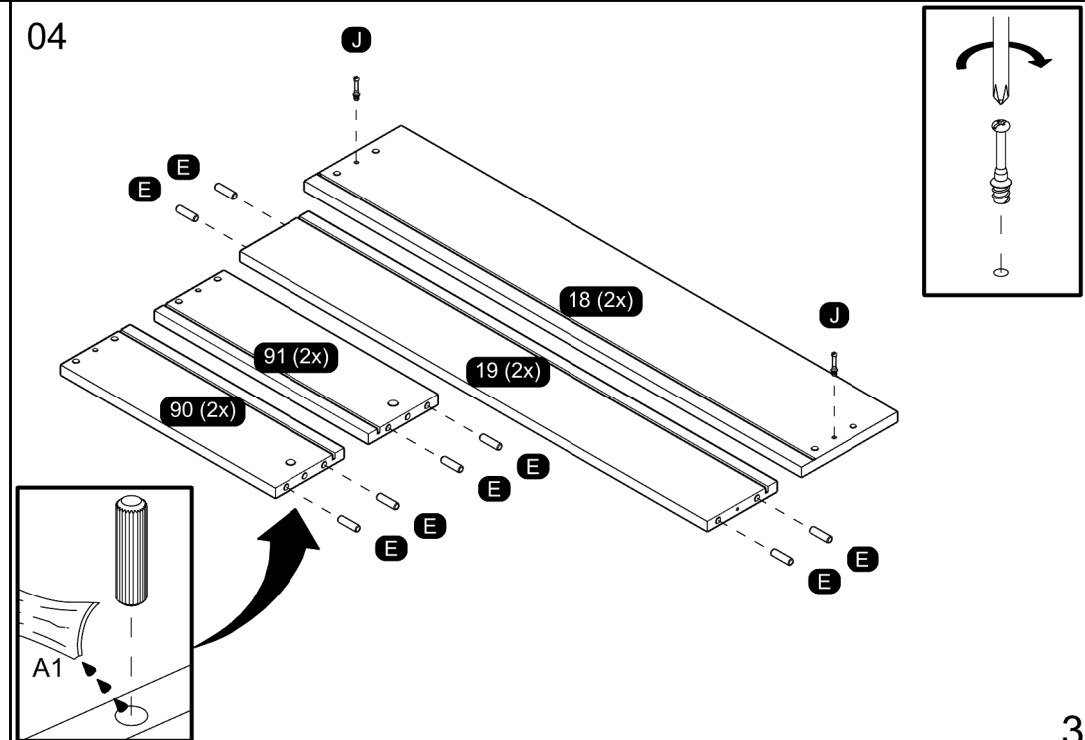

05

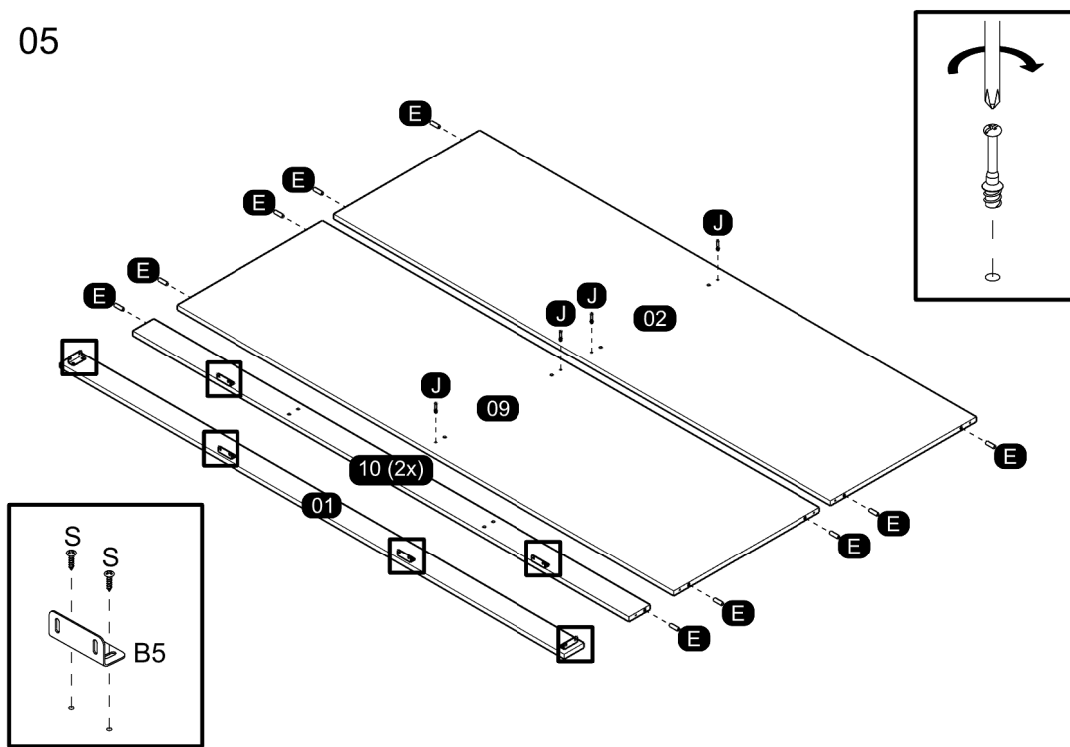

07

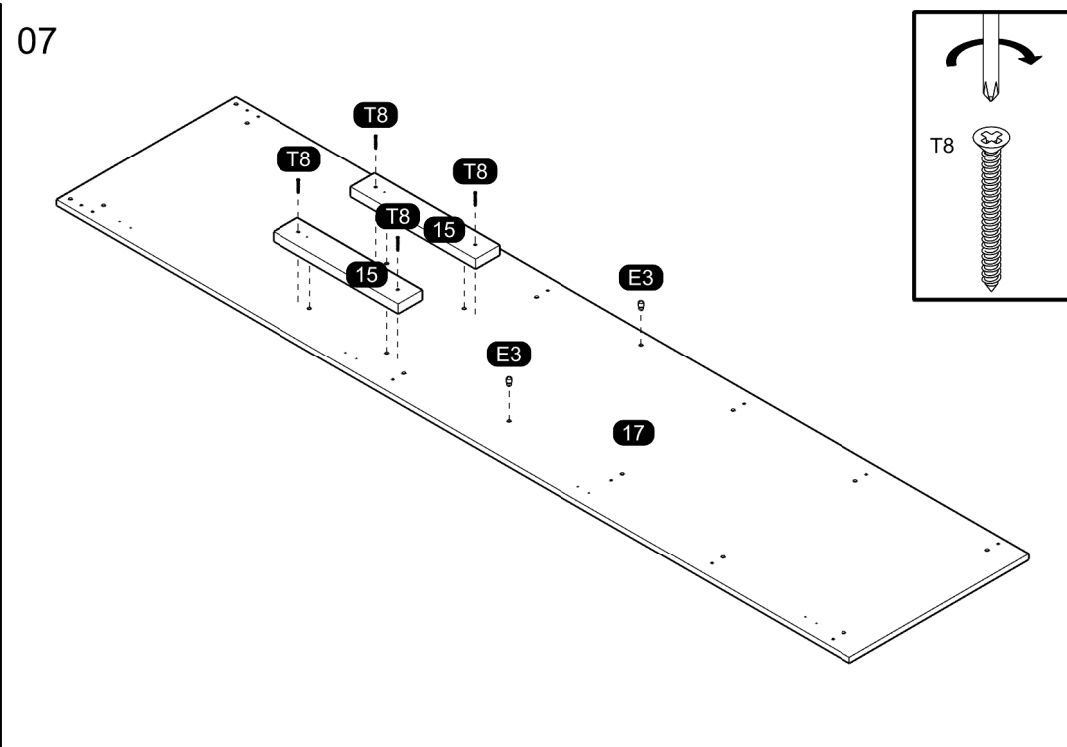

06

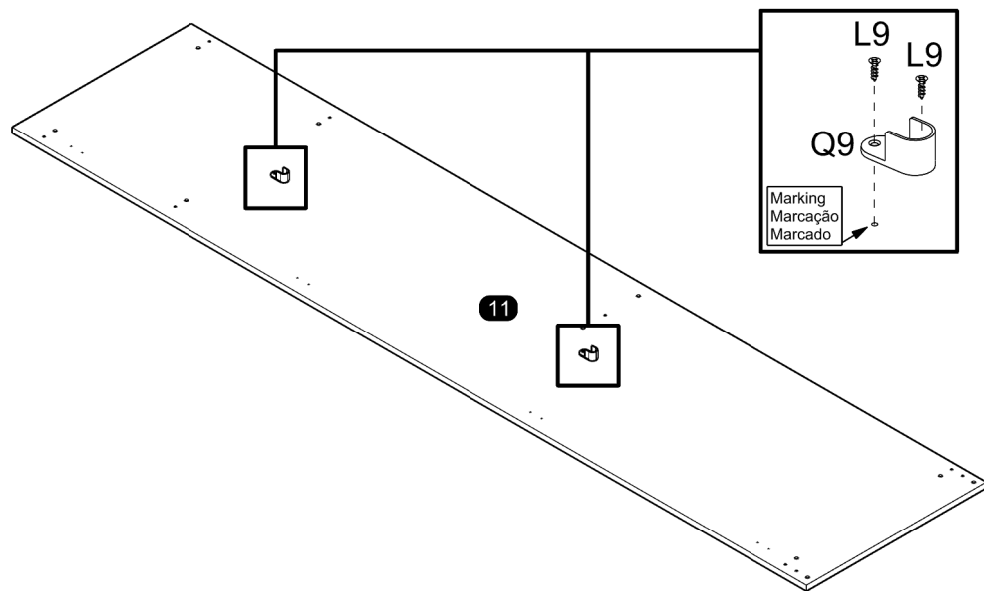

08

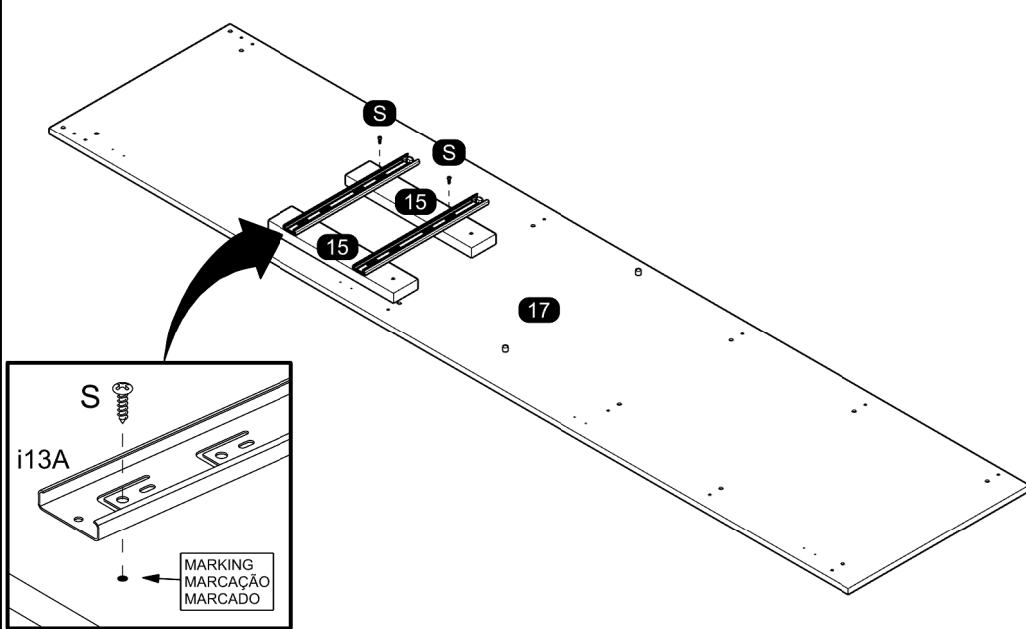

09

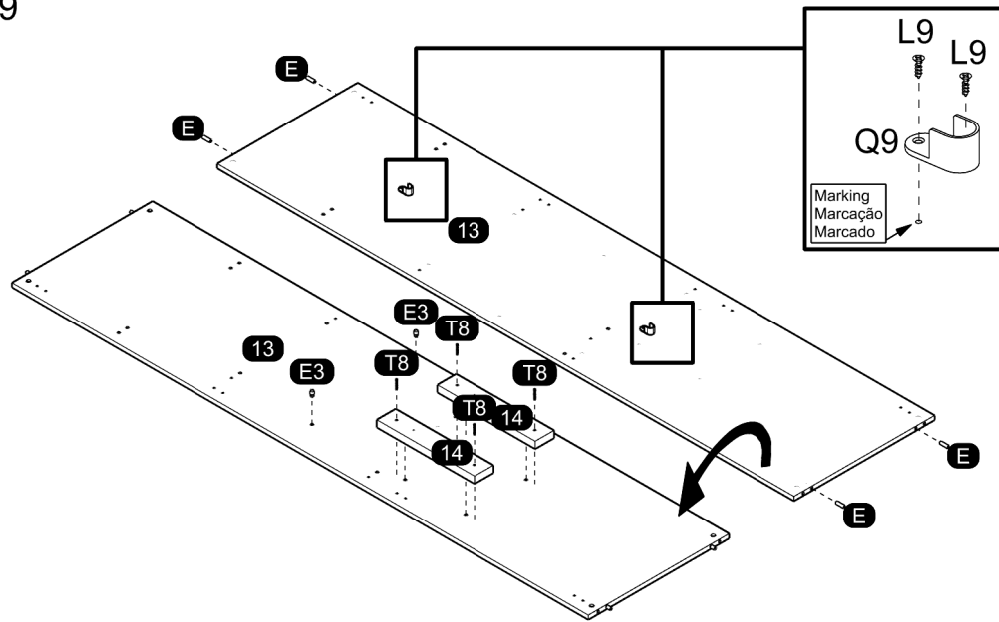

# ASSEMBLY MONTAGEM / ARMADO

11

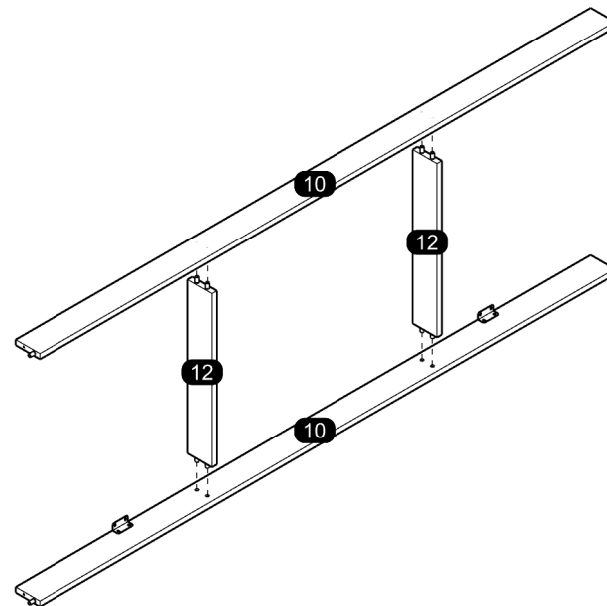

10

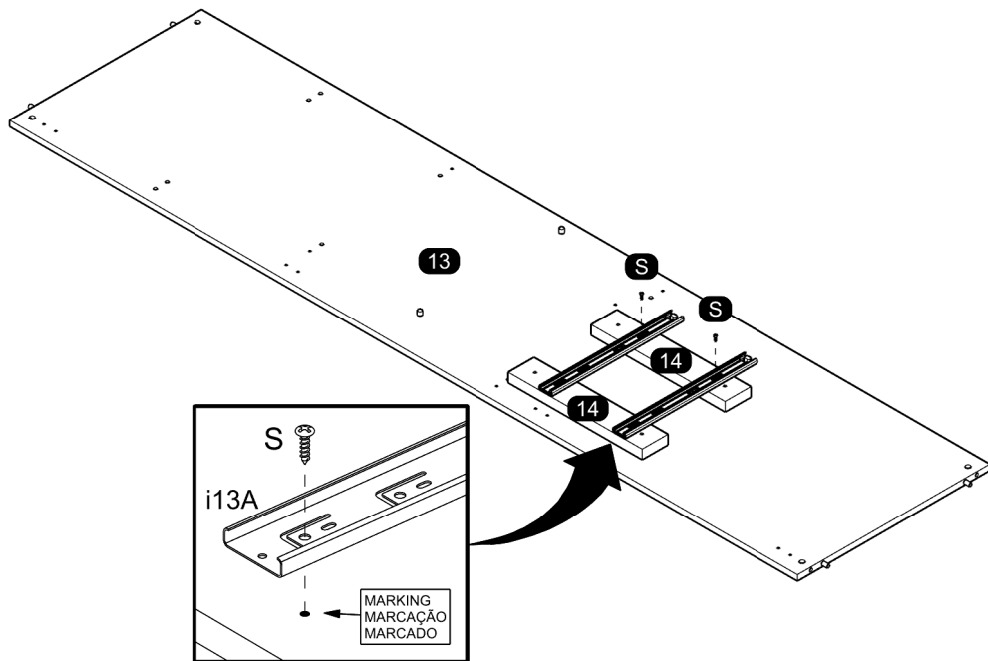

12

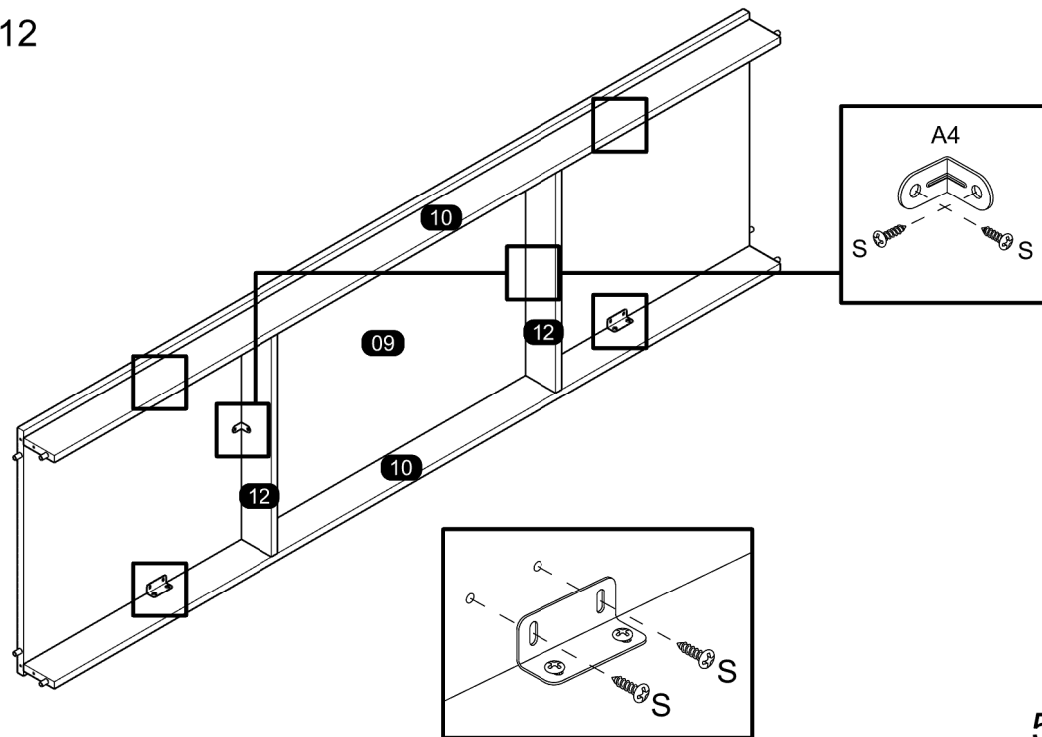

13

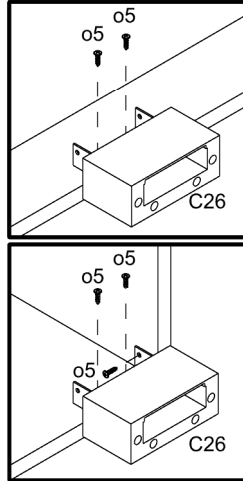
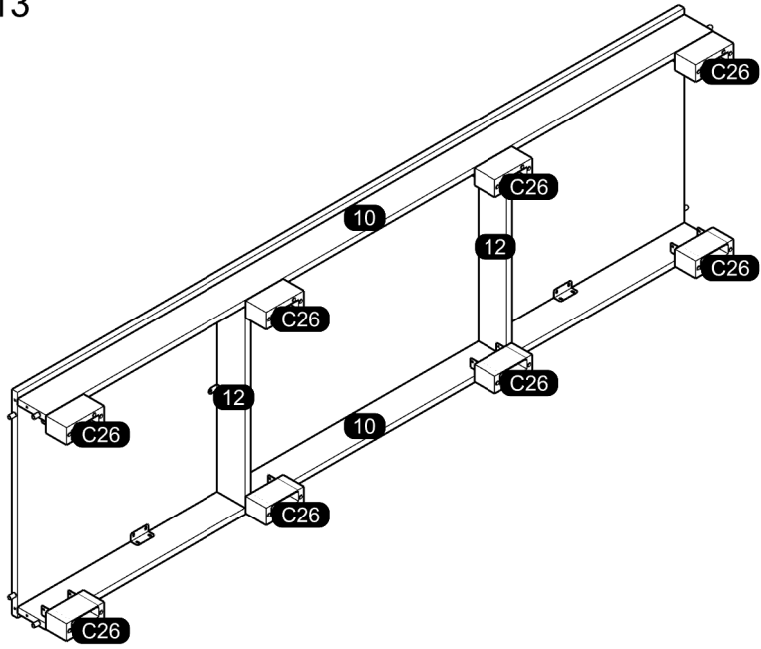

15

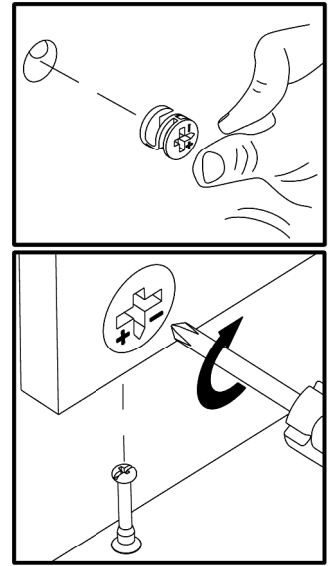
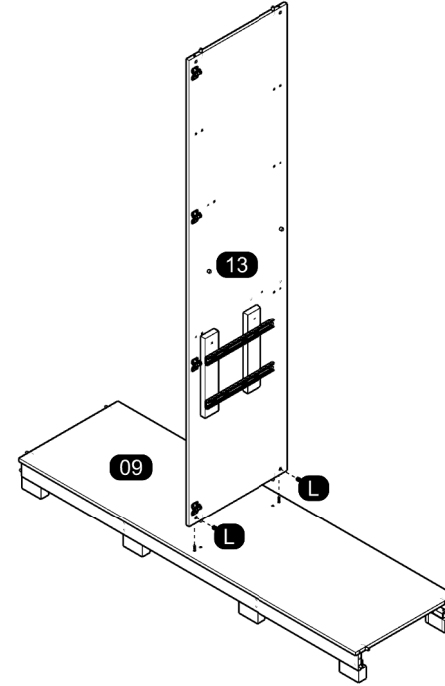

14

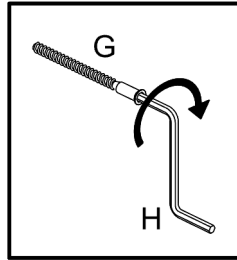
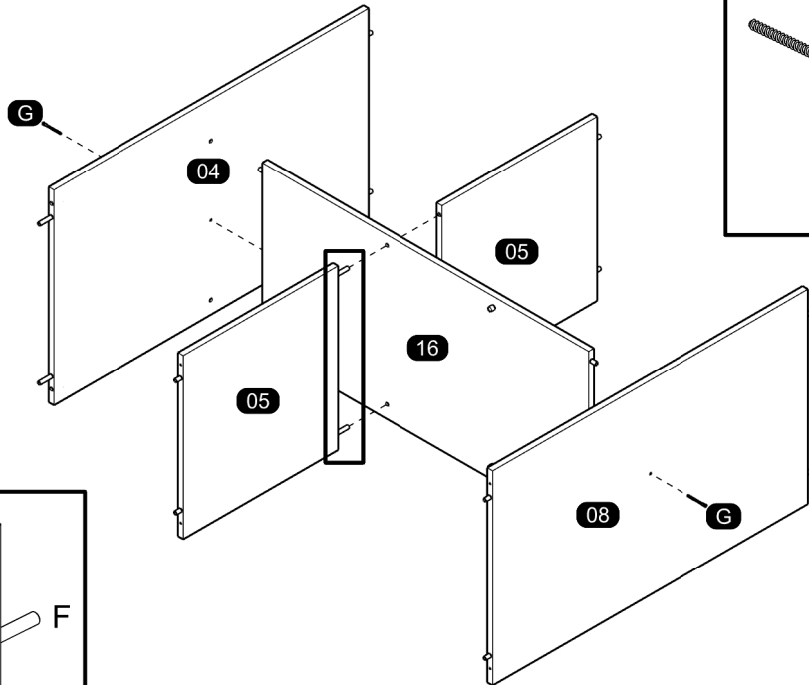

16

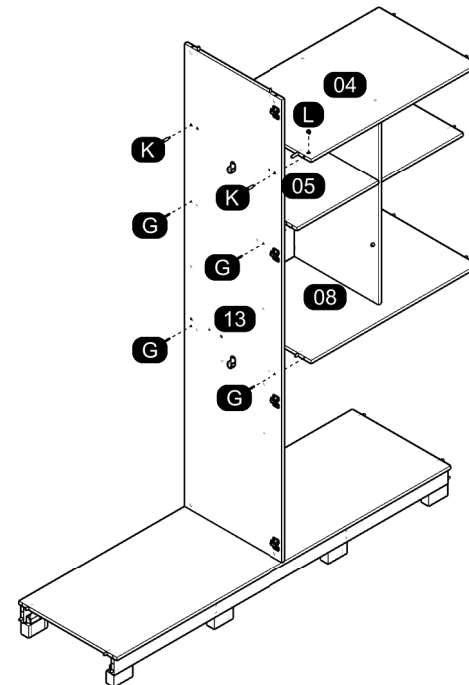
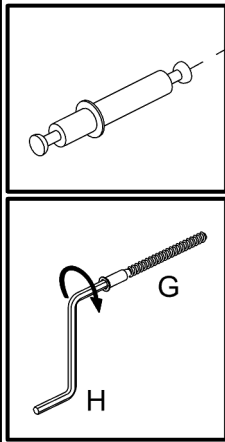

17

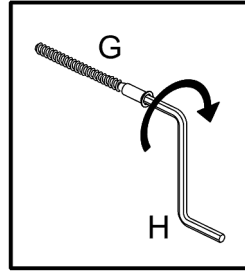
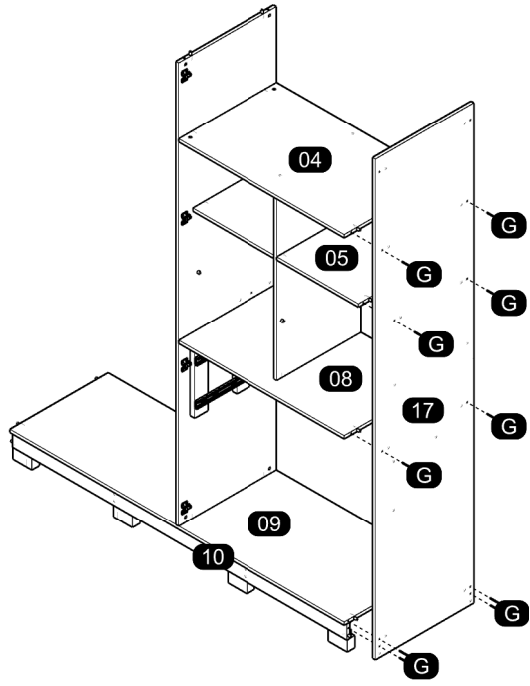

19

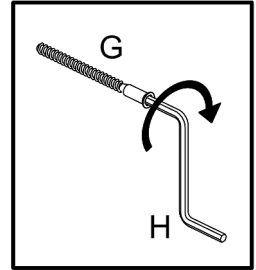
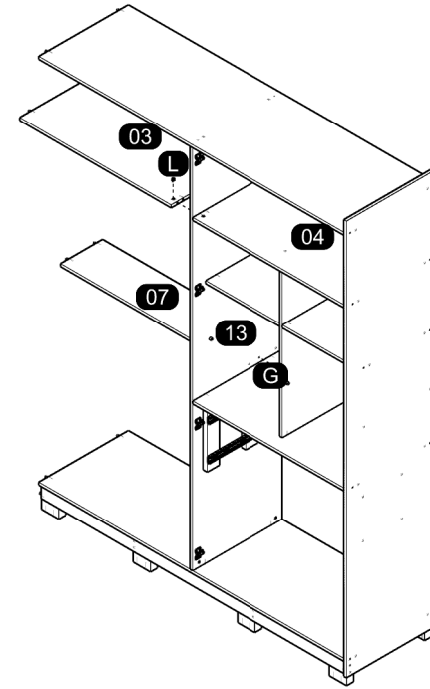
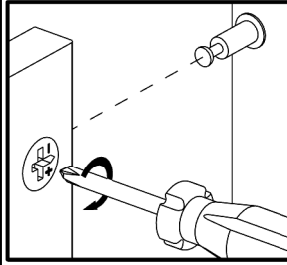

18

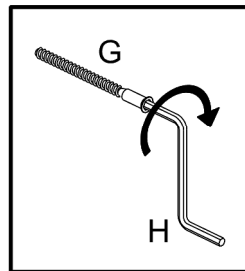
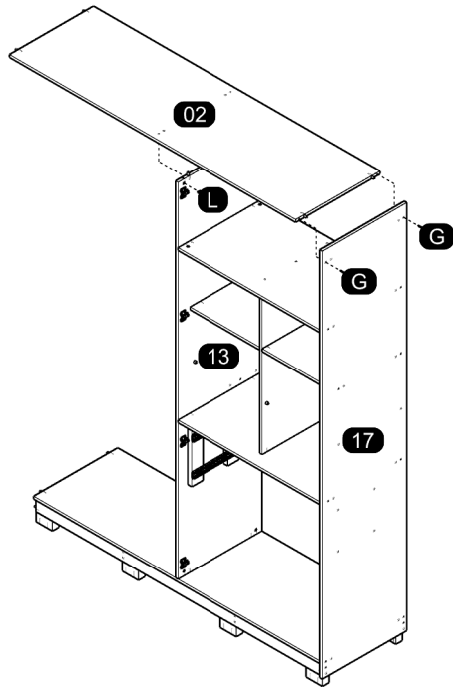
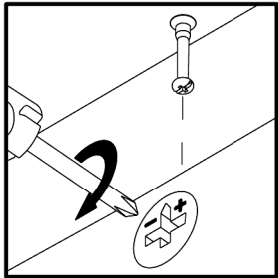

20

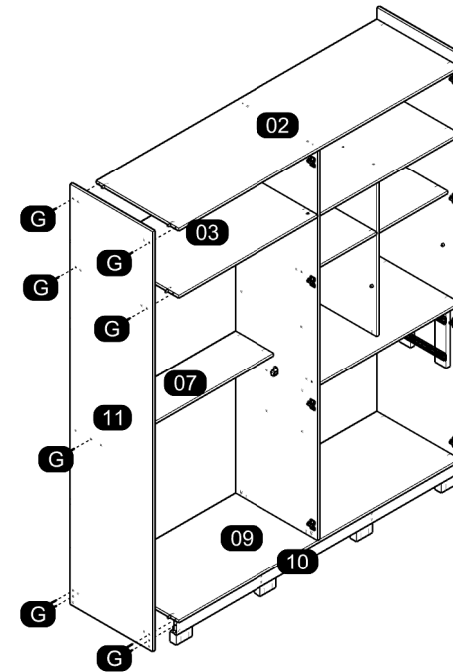
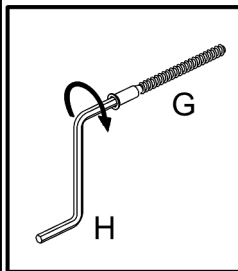

21

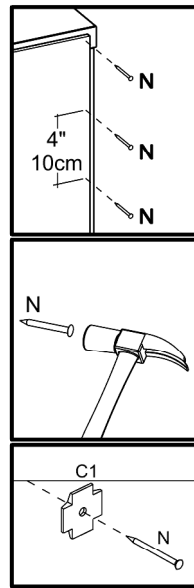
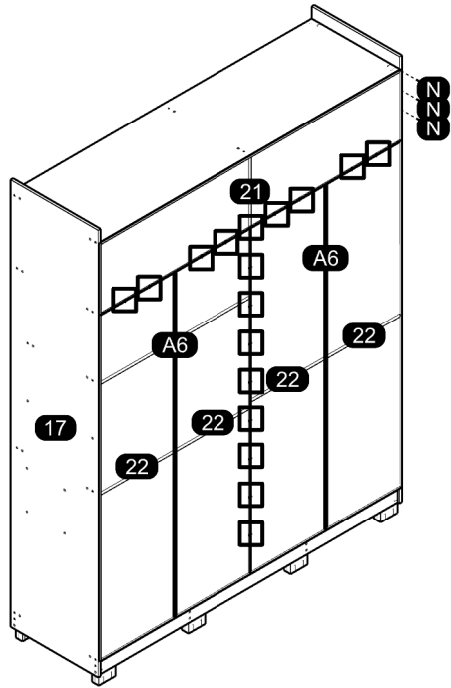

23

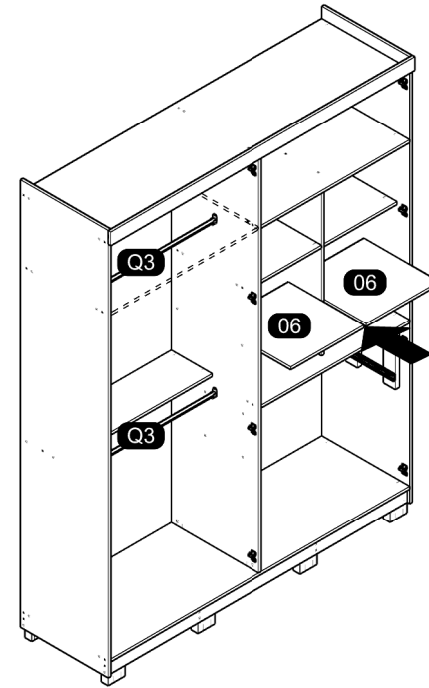
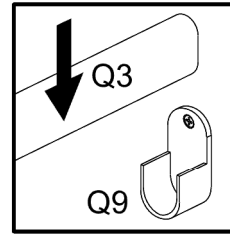

22

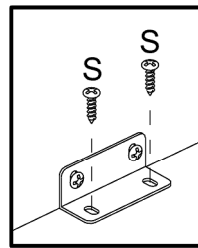
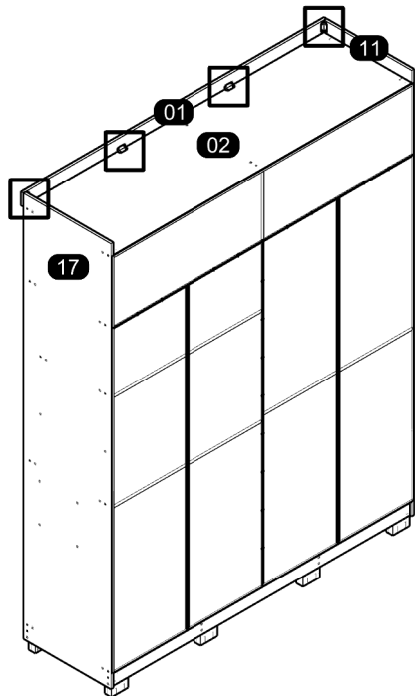

24

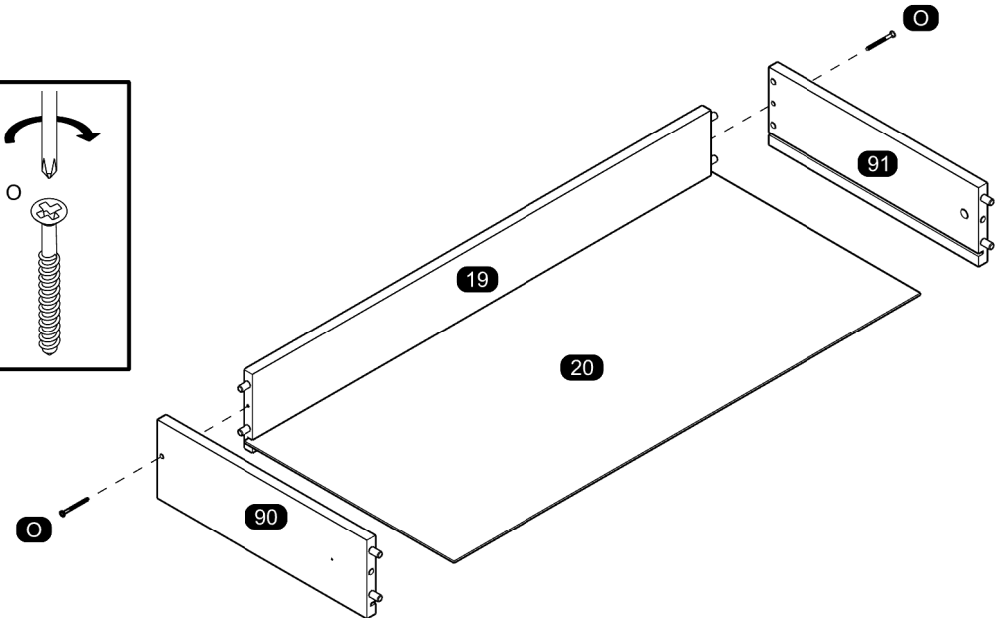
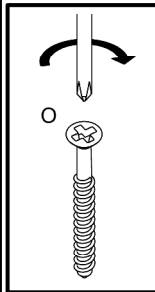

25

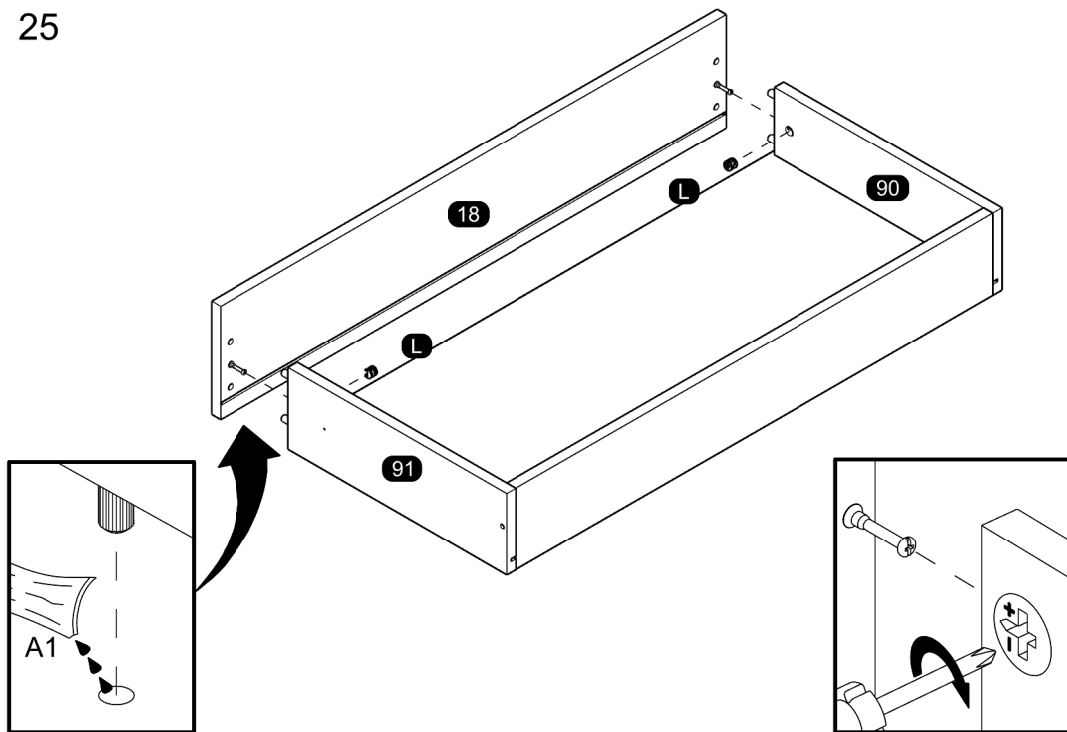

27

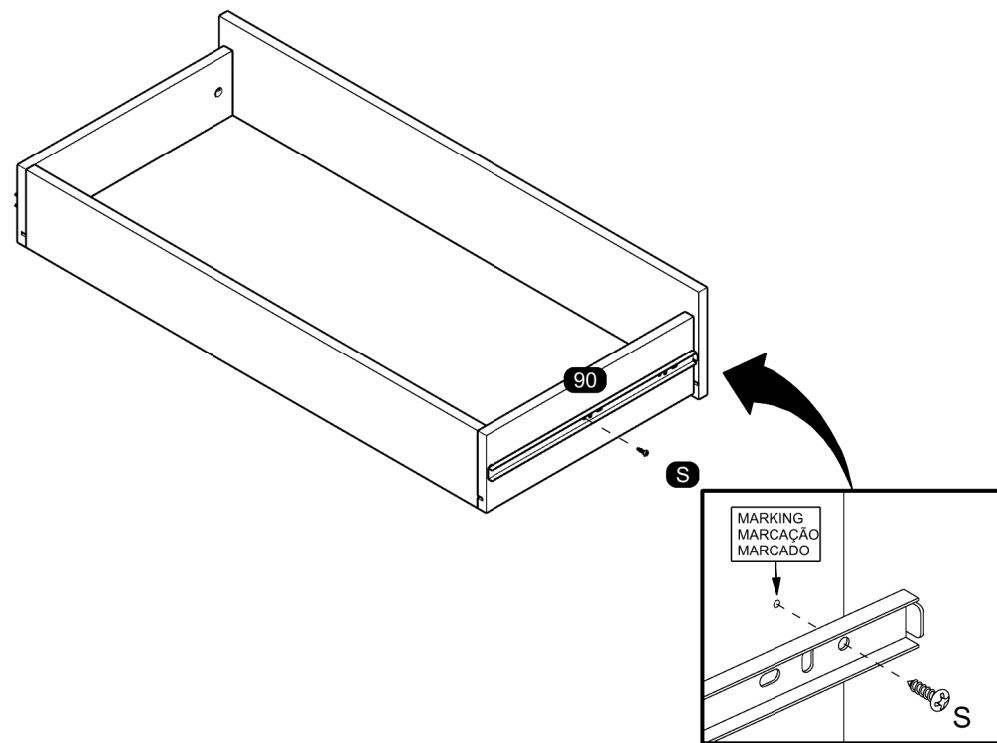

26

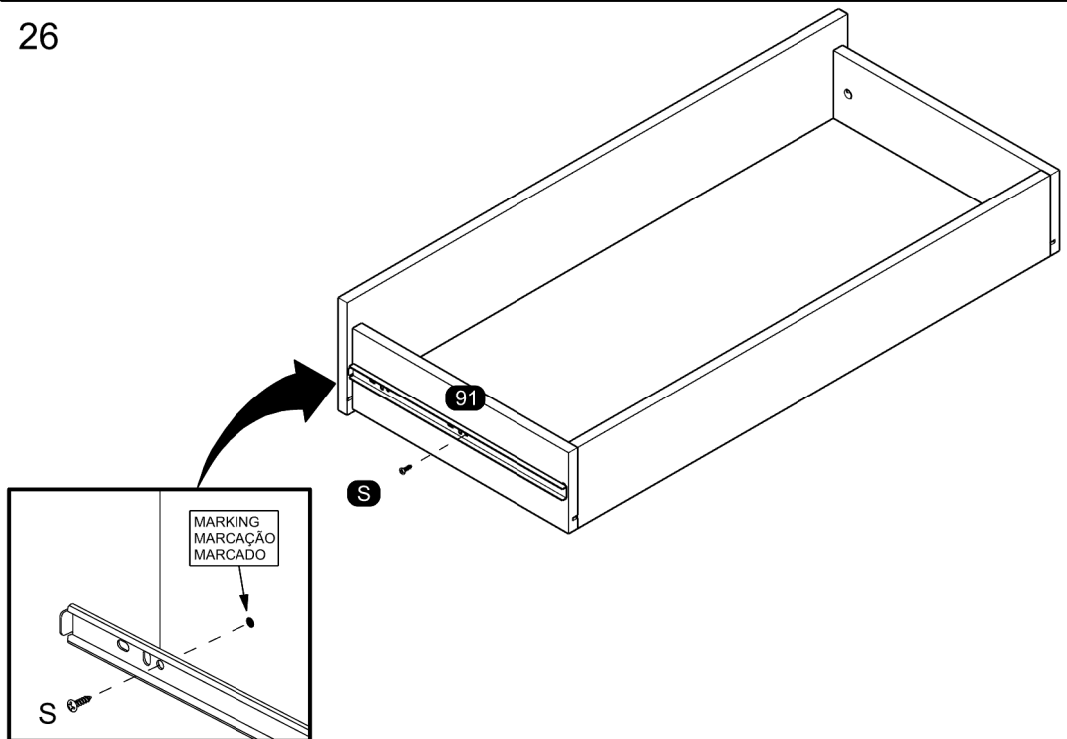

28

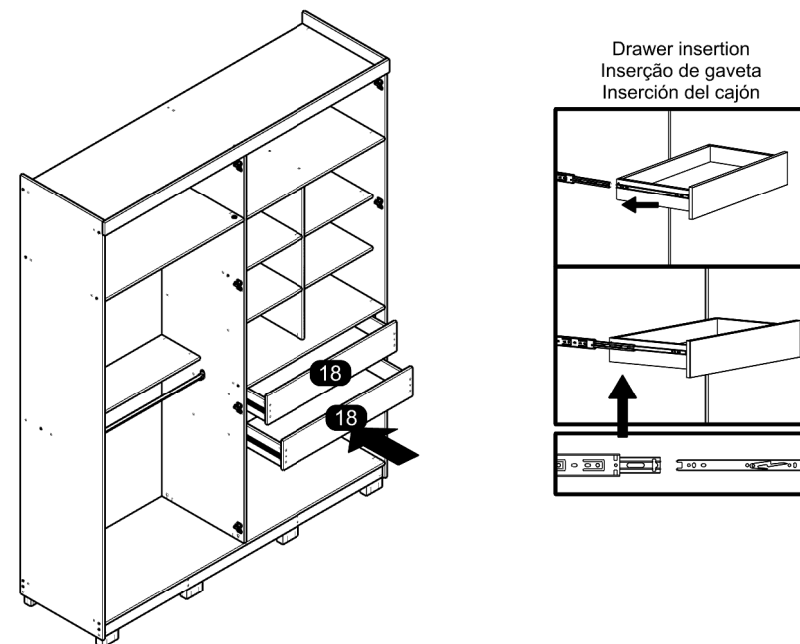

At the end of the assembly, insert the screw cover / hole plugs in the apparent holes.  
 Ao final da montagem, insira a(s) tampa(s) de parafuso / tapa furos nos furos que ficarem aparentes.  
 Al final del conjunto, coloque la tapa tornillo / tapón plástico en los agujeros que se hagan evidentes.

MOUNTING ON THE CHOSEN DOOR MODEL  
 MONTAGEM NO MODELO DE PORTA ESCOLHIDO / MONTAJE EN EL MODELO DE PUERTA ELEGIDO

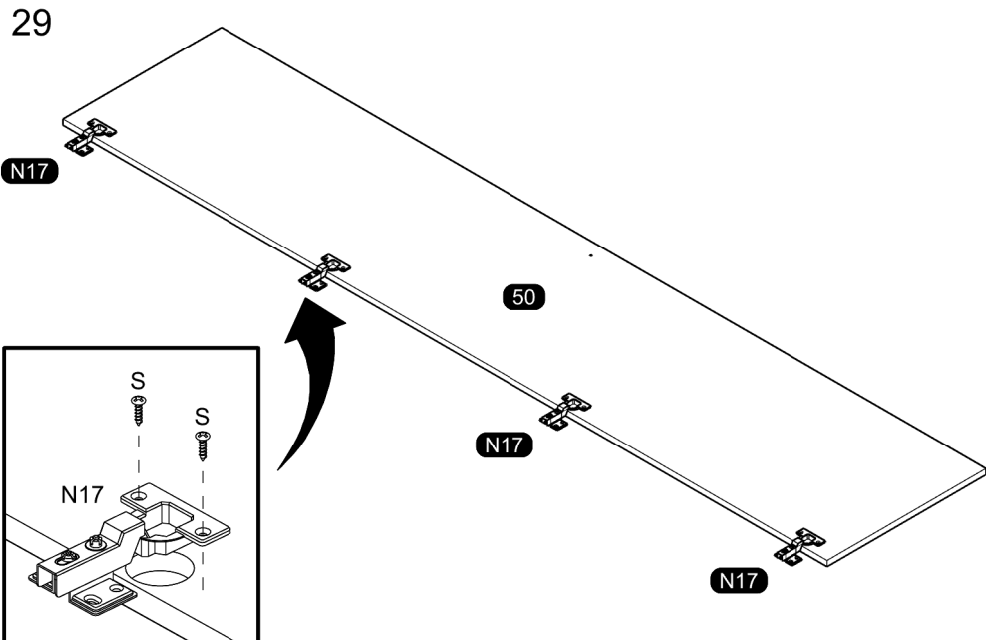

31

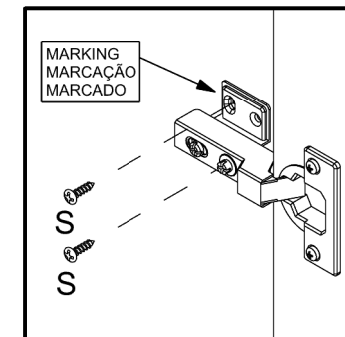
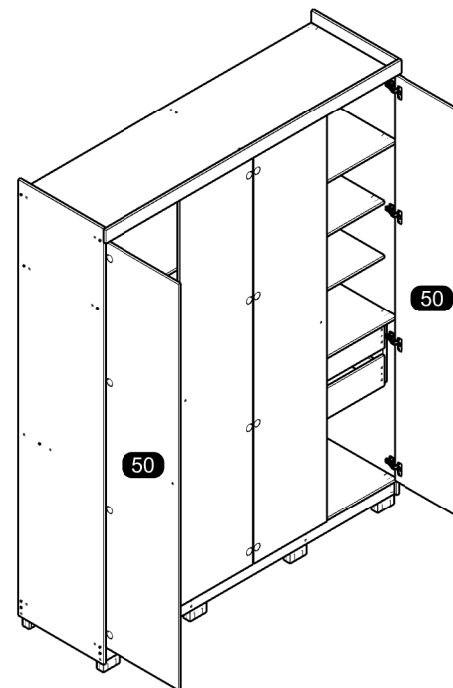

30

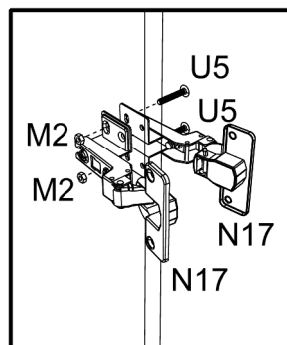
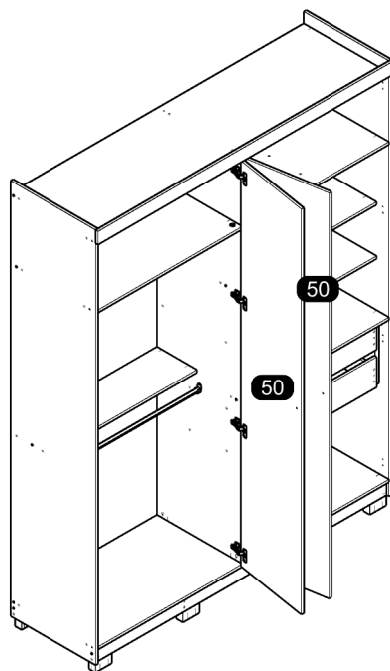

32

