

Item	Caixa Caja Box	Qtd Ctd Qty	Descrição   Descripción   Description	Medidas (mm)   Dimensions (mm)   Size (measurements) (mm)
01	2/2	01	Rodapé frontal   Rodapié frontal   Front footboards	1566x120x12
02	1/2	01	Travessa do Rodapé   Rodapié Bandeja   Footboard Platter	390x120x12
03	2/2	01	Rodapé traseiro   Rodapié trasero   Rear footboard	1566x120x12
04 = 08	1/2	01	Base   Base   Base	526x420x12
05	1/2	01	Divisão Esquerda   División izquierda   Left Division	1368x420x12
06	1/2	01	Lateral esquerda   Lateral izquierda   Left side	1950x420x12
07 = 12	1/2	02	Prateleira   Estante   Shelf	514x350x12
08 = 04	1/2	01	Base   Base   Base	526x420x12
09	1/2	01	Divisão Direita   División derecha   Right Division	1368x420x12
10	1/2	01	Travessa Frontal   Travesaño delantero   Front cross member	514x60x12
11	1/2	01	Tampo das gavetas   Tapa de los cajones   Drawers cover	514x420x12
12 = 07	1/2	01	Prateleira   Estante   Shelf	514x350x12
13	1/2	01	Chão do Maleiro   Piso Maleiro   Trunk floor	1566x420x12
14	1/2	02	Ripa do Maleiro   Ripa del Maleiro   Maleiro's Slat	350x73x12
15	1/2	01	Prateleira Menor   Estante más pequeño   Smaller Shelf	514x250x12
16	1/2	01	Lateral direita   Lateral derecha   Right side	1950x420x12
17	1/2	01	Tampo   Tapa   Top	1566x420x12
18	2/2	01	Chapéu   Sombrero   Hat	1588x80x15
19	1/2	01	Fundo Superior   Fondo Superior   Upper Fund	1584x367x3
20	2/2	03	Fundo   Fondo   Background	1386x527x3
21	2/2	03	Frente de Gaveta   Frente del Cajón   Drawer Front	524x152x15
22	1/2	06	Lado de gaveta   Lado del cajón   Drawer side	350x100x12
23	1/2	03	Ripa de trás   Listón trasero   Back slat	489x100x12
24	1/2	03	Fundo de gaveta   Fondo de cajón   Drawer bottom	488x367x3
25	2/2	02	Porta Maior   Puerta Mayor   Greater Door	1740x300x15
26	2/2	02	Porta   Puerta   Door	1740x220x15
27	2/2	06	Aplique   Aplicar   Apply	1740x30x12
28	2/2	02	Porta Menor   Puerta menor   Smaller Door	1215x260x15

FERRAGENS | HERRAJES | HARDWARE

<b>A</b> 36x  Parafuso 3,5x40mm CHT. Tornillo 3,5x40mm CHT. Screw 3,5x40mm CHT.	<b>B</b> 30x  Parafuso 4,0x25mm CHT. Tornillo 4,0x25mm CHT. Screw 4,0x25mm CHT.	<b>C</b> 04x  Parafuso 4,0x22mm MET. FLA. Tornillo 4,0x22mm MET.FLA. Screw 4,0x22mm MET. FLA.	<b>D</b> 14x  Parafuso 3,5x25mm FLA. Tornillo 3,5x25mm FLA. Screw 3,5x25mm FLA.	<b>E</b> 134x  Parafuso 3,5x12mm CHT. Tornillo 3,5x12mm CHT. Screw 3,5x12mm CHT.
<b>F</b> 24x  Parafuso 3,0x16mm CHT. Tornillo 3,0x16mm CHT. Screw 3,0x16mm CHT.	<b>G</b> 80x  Cavilha Plástica 5x25mm Pasador de plástico de 5 x 25 mm Plastic Dowel 5x25mm	<b>H</b> 06x  Prego 12x12mm Anelado Clavo 12x12 mm Anillado Ringed Nails 12x12mm	<b>I</b> 103x  Prego 10x10mm Clavo 10x10mm Nail 10x10mm	<b>J</b> 32x  Fixador de fundos Fijador de fondos Bottom fixer
<b>K</b> 04x  Suporte cabideiro Soporte de percha Coat hanger support	<b>L</b> 17x  Cantoneira plástica Cantenera plástica Plastic angle brackets	<b>M</b> 04x  Porca sextavada Tuerca hexagonal Hexagon nuts	<b>N</b> 03x PAR  Corrediça metal 350mm Corredera metal 350mm Sliding metal 350mm	<b>O</b> 06x  Pé "U" 50x40x100mm Pie "U" 50x40x100mm 50x40x100mm "U" feet
<b>P</b> 07x  Perfil Puxador Revestido MDF 250mm Perfil Tirador Revestido MDF 250mm Profile MDF 250mm Coated Handle	<b>Q</b> 18x  Dobradiça metal 26mm Bisagra de metal 26mm 26 mm metal hinge	<b>R</b> 18x  Calço metal 5mm Calzado metálico 5mm 5 mm metal shim	<b>S</b> 02x  Cabideiro Madeira 508mm Cabezal Madera 508mm 508mm wooden hanger	<b>T</b> 01x  Sachê de cola Bolsa de pegamento Glue bag
<b>U</b> 60x  Adesivo tapa parafuso 10mm Adhesivo tapón de tornillo 10mm Bolt cover adhesive 10mm	<b>V</b> 03x  Giz de correção Tiza de corrección Chalk of correction	<b>W</b> 01x  Etiqueta resinada Briz Etiqueta resinada Briz Briz resin label		



Ind. e Com. de Móveis Henn  
Mondai - SC - Brasil

+55 49 3674.3500

@moveishenn  
www.henn.com.br

INSTRUÇÕES DE MONTAGEM

INSTRUCCIONES DE MONTAJE  
ASSEMBLY INSTRUCTIONS

Roupeiro 06 Portas 03 Gavetas / Armario 06 Puertas 03 Cajones / Wardrobe with 06 doors and 3 drawers

B375-127 Nature/Off White  
B375-215 Nature/Preto HP  
B375-222 Nature/Avelã

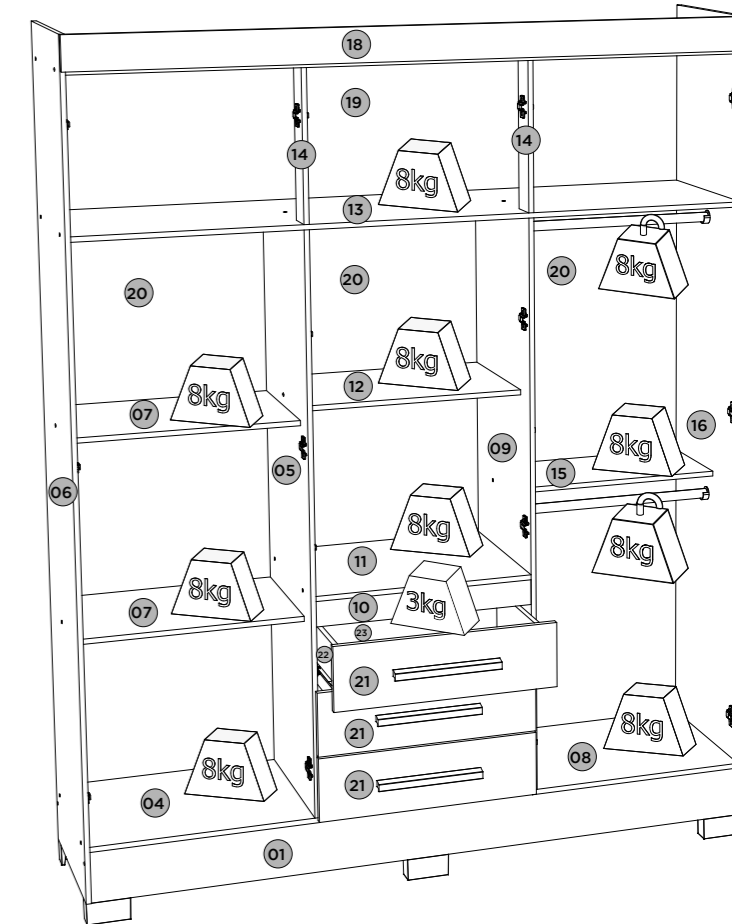
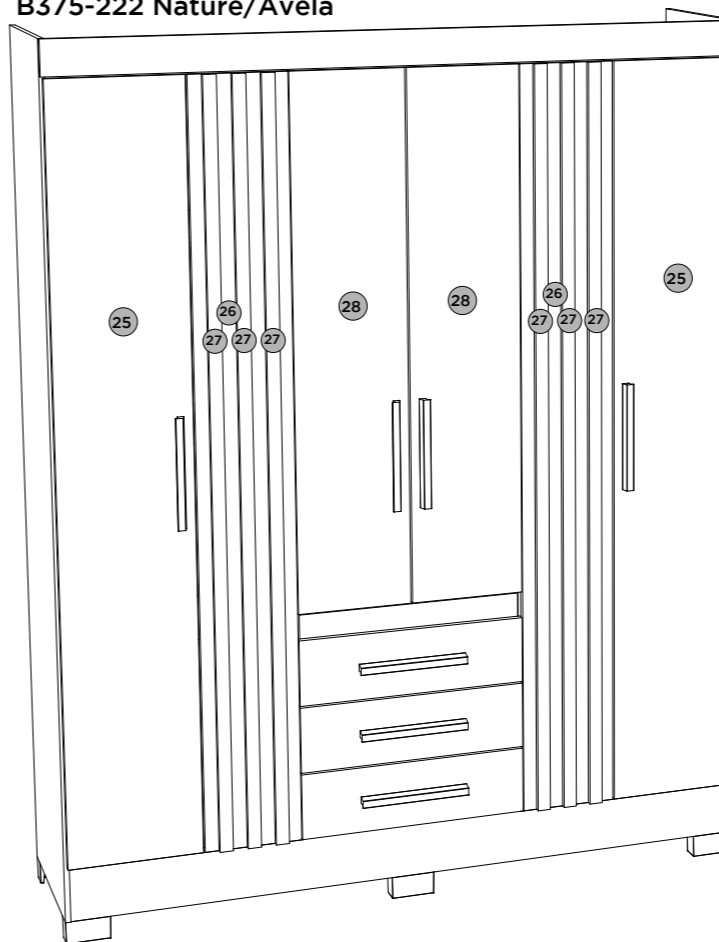

Pesos máximos recomendados com carga distribuída  
Peso máximo recomendado con la carga distribuida  
Recommended maximum weights with evenly distributed.

Requisitos para montagem  
Requisitos para la montaje  
Assembly Requirements

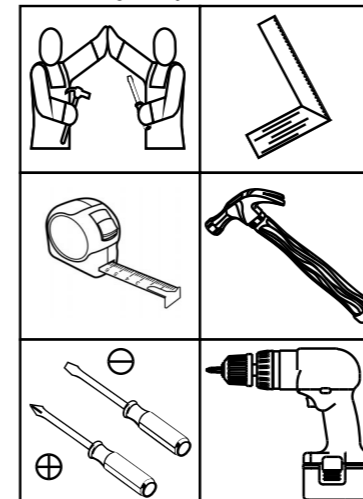

Imagens meramente ilustrativas,  
não acompanha o produto.  
Imágenes ilustrativas, no incluidas  
con el producto.  
Illustrative images, not included  
with the product.

AVISO

Para limpeza de seu móvel, use uma flanela seca ou umedecida, e não utilize produtos químicos que possam danificar seu produto.

SISTEMA DE MONTAGEM

O sistema de montagem dos produtos, funciona de acordo com a ordem crescente dos números indicados no desenho. Ex: 01, 02, 03, 04... até a conclusão da montagem.

ASSISTÊNCIA TÉCNICA

Para solicitação de Assistência Técnica você consumidor deverá entrar em contato com o Lojista o qual você realizou a compra deste produto e solicitar a assistência técnica das peças avariadas. A garantia abrange todas as peças, partes e componentes que eventualmente venham apresentar defeito de fabricação no prazo de 03 (três) meses, contando a partir da entrega do produto ao consumidor, mediante nota fiscal de compra. Se houver qualquer alteração na estrutura do produto ou ocorrer defeito por negligência do montador/consumidor em relação a instrução de montagem e manuseio, não será fornecido assistência técnica gratuita.

ADVERTENCIA

Para limpieza de su móvil, use una franela seca o húmeda, y no utilice productos químicos que puedan dañar su producto.

SISTEMA DE MONTAJE

El sistema de montaje de los productos funciona de acuerdo con el orden creciente de los números indicados en el dibujo. Ej.: 01, 02, 03, 04... hasta la conclusión del montaje.

ASSISTENCIA TÉCNICA

Para solicitar Asistencia Técnica, el consumidor debe comunicarse con el Comercio que usted realizó la compra de este producto y solicita asistencia técnica para las partes dañadas. La garantía cubre todas las partes, piezas y componentes que eventualmente puedan presentar defecto de fabricación en el plazo de 03 (tres) meses, contados a partir de la entrega del producto al consumidor, mediante factura de compra. Si se produce algún cambio en la estructura del producto o se produce un defecto por negligencia del montador/consumidor en relación con las instrucciones de montaje y manipulación, no se prestará asistencia técnica gratuita.

NOTICE

To clean your furniture, use a dry or wet cloth, and do not use chemicals that may damage your product.

ASSEMBLY SYSTEM

The products' assembly system works according to the increasing order of the indicated numbers. For example: 01, 02, 03, 04 ... to the end of the assembly.

TECHNICAL ASSISTANCE

To request Technical Assistance, the consumer must contact the retailer from whom you purchased this product and request technical assistance for the damaged parts. The warranty covers all parts, parts and components that may eventually present a manufacturing defect within a period of 03 (three) months, counting from the delivery of the product to the consumer, by means of a purchase invoice. If there is any change in the structure of the product or defect occurs due to negligence of the assembler/consumer in relation to the assembly and handling instruction, free technical assistance will not be provided.

1

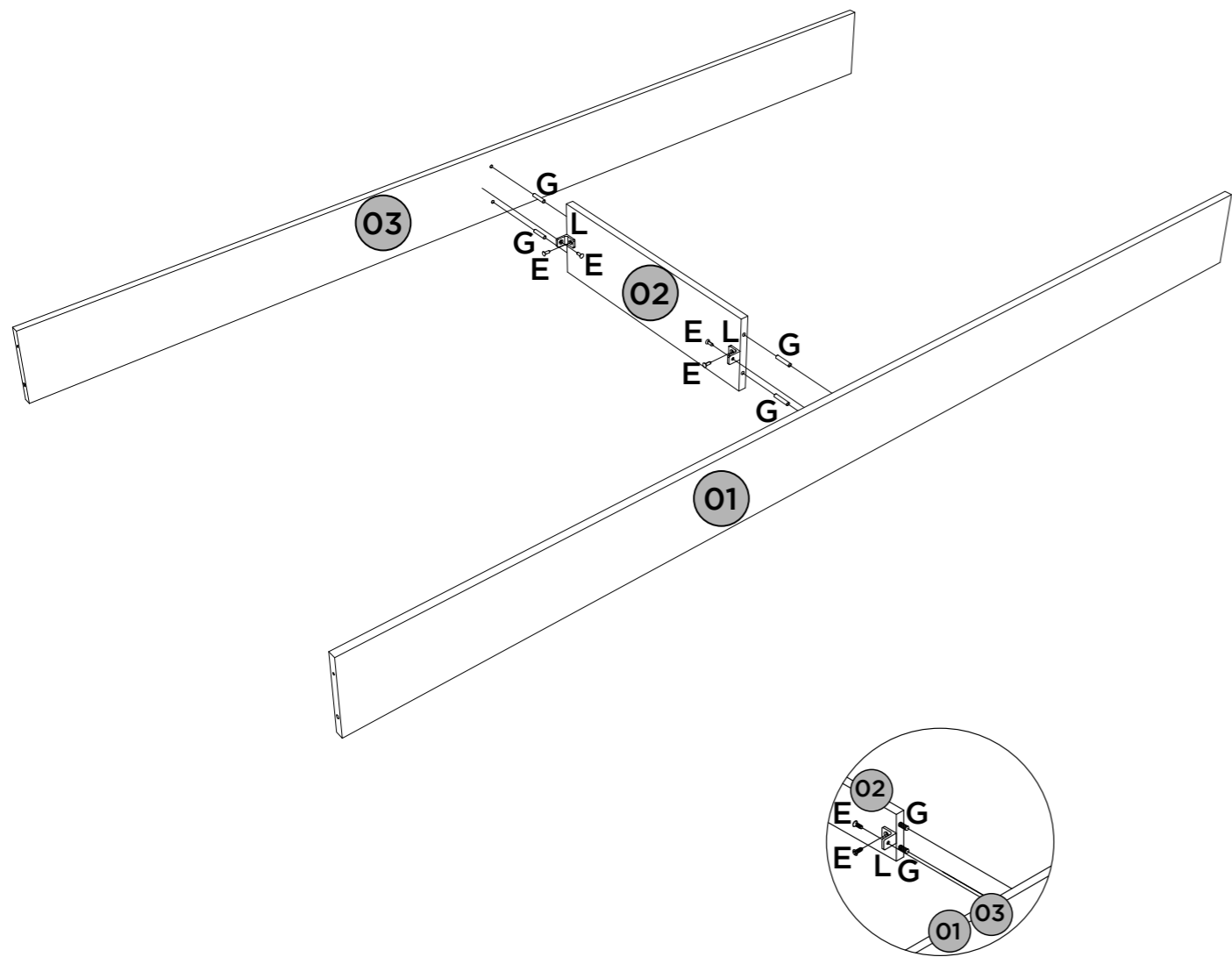

2

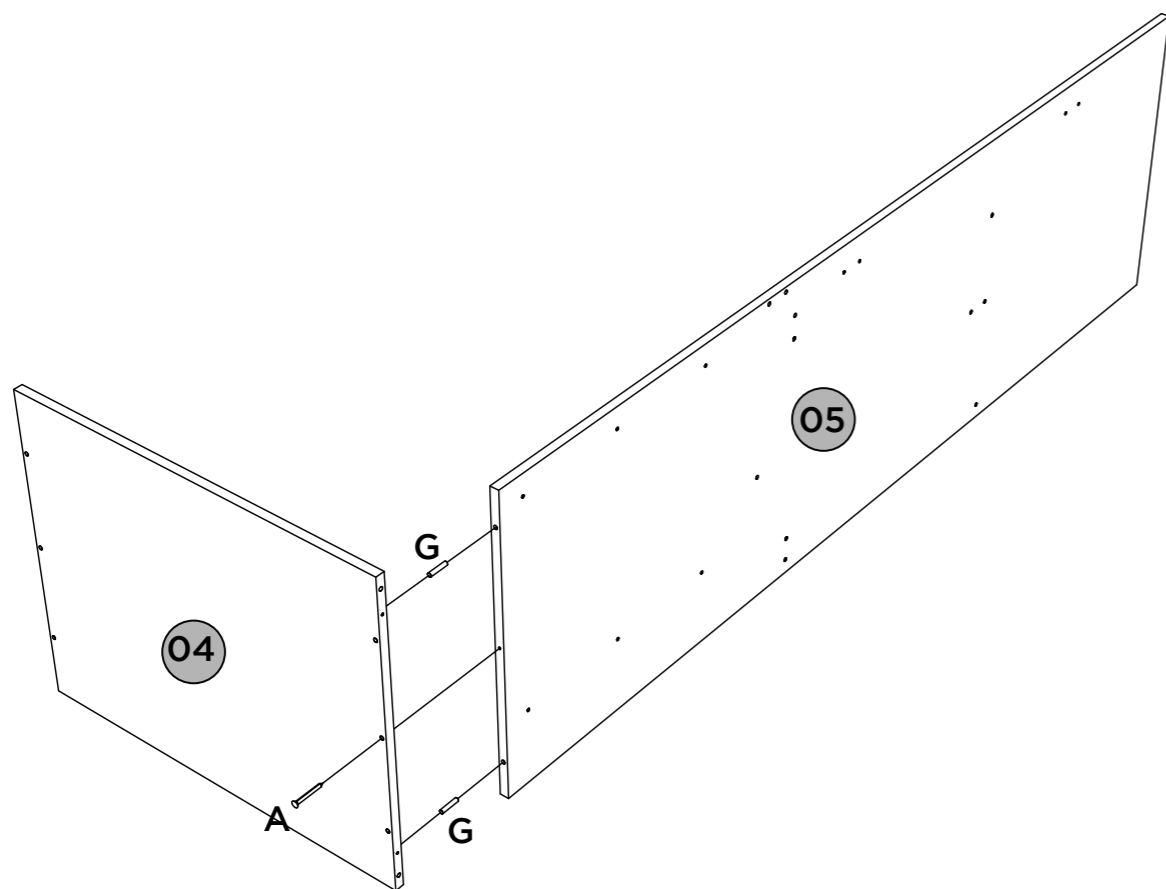

14

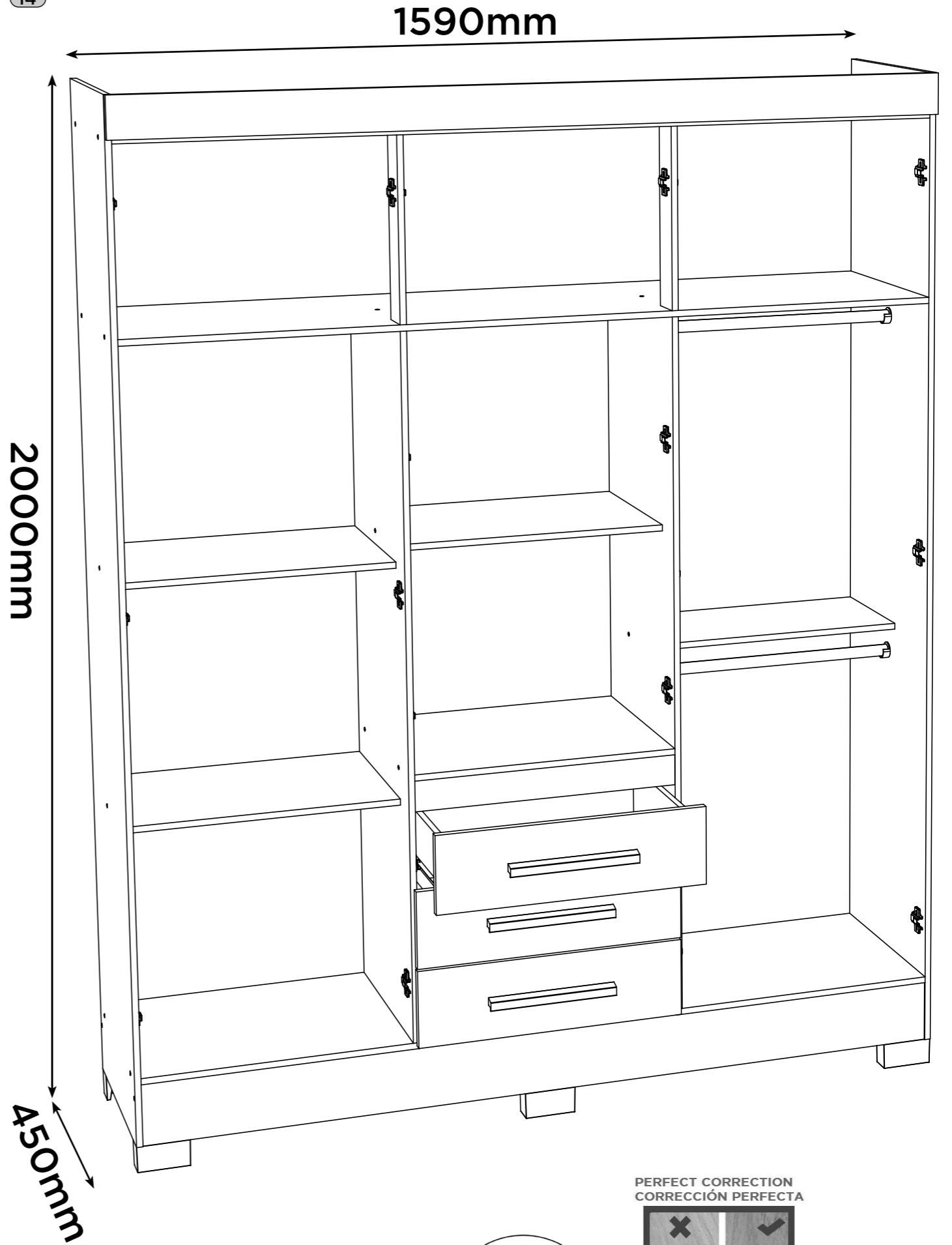

PERFECT CORRECTION  
CORRECCIÓN PERFECTA

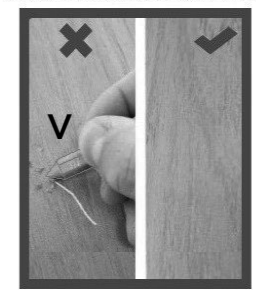
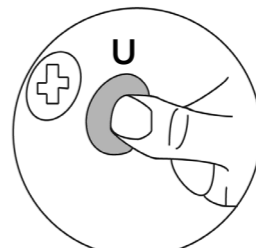

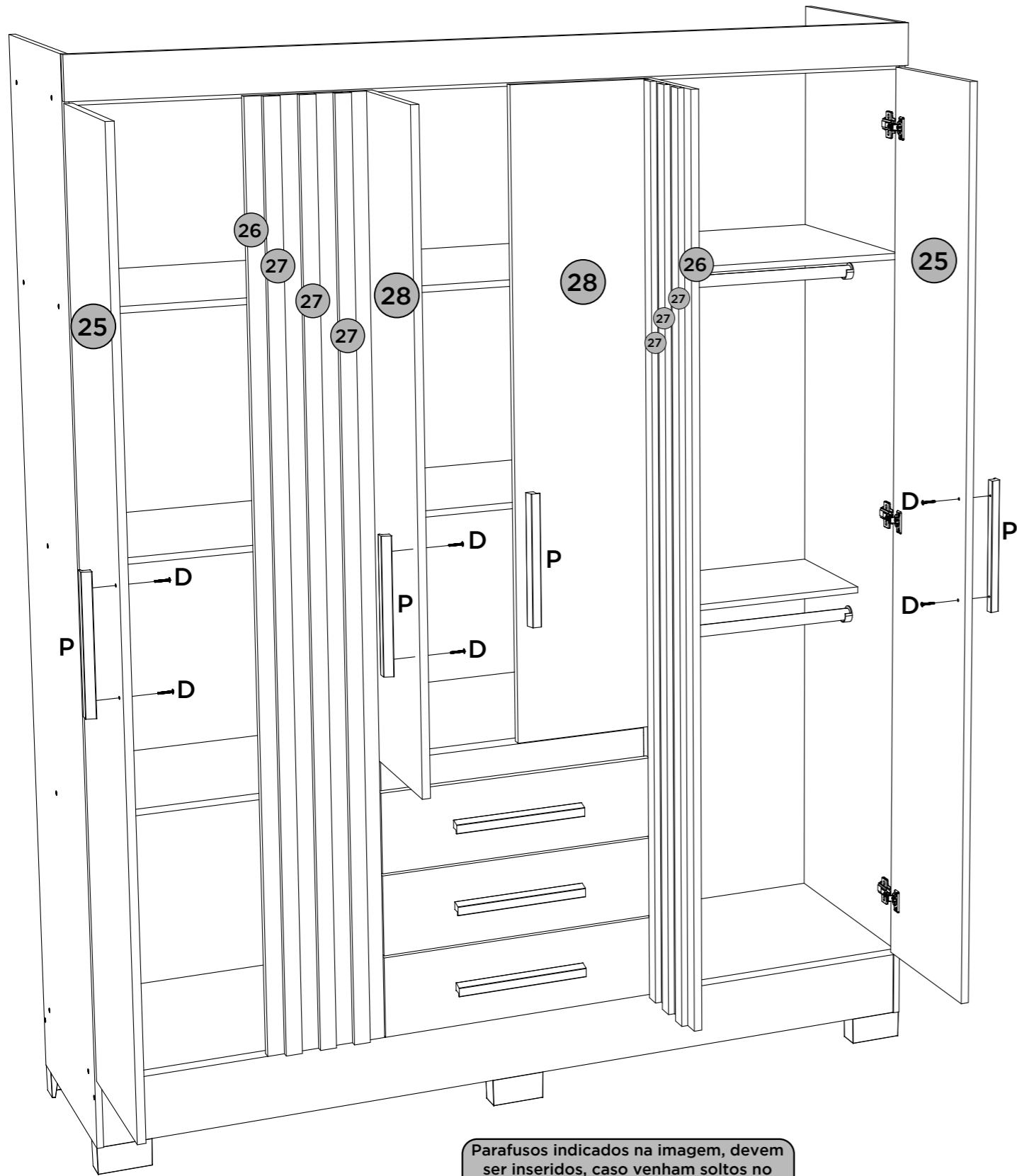

Parafusos indicados na imagem, devem ser inseridos, caso venham soltos no pacote.

Los tornillos indicados en la imagen deben ser insertados, si se sueltan en el paquete.

Screws indicated in the image must be inserted if they are loose in the package.

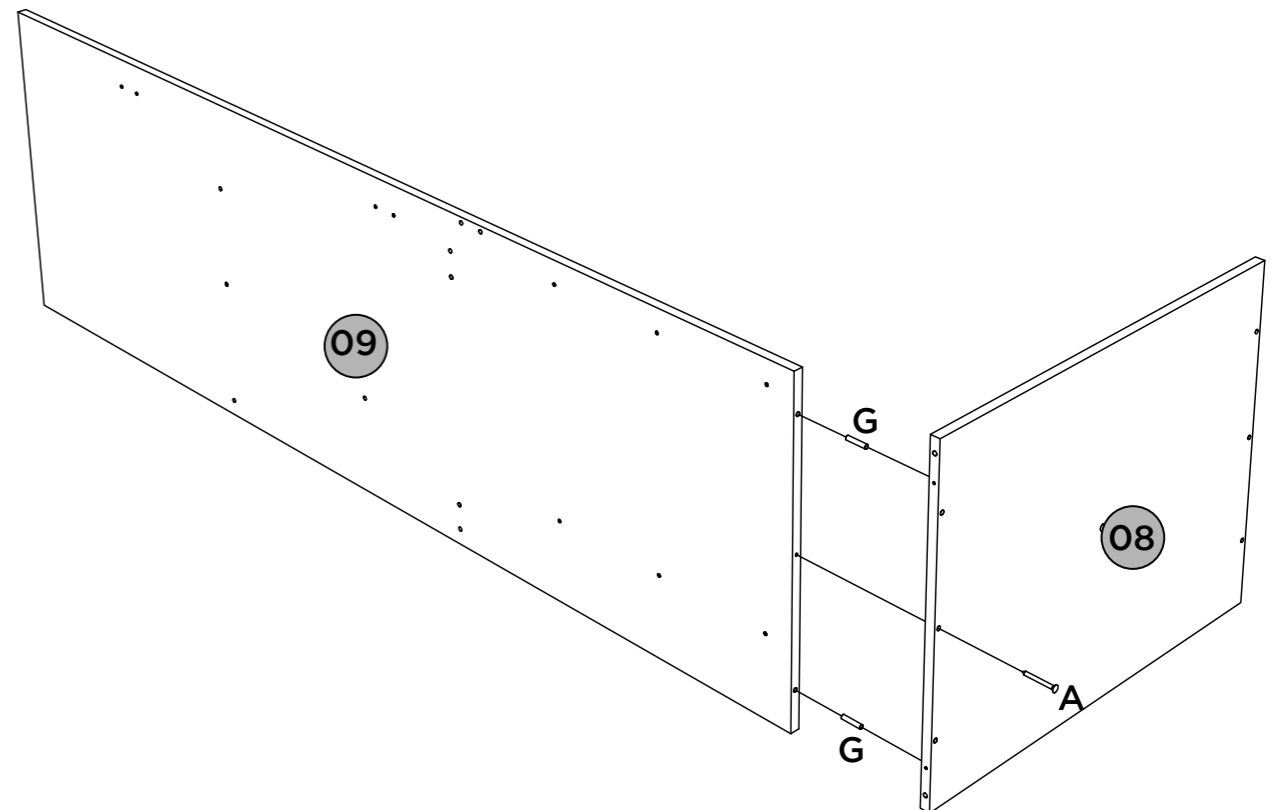
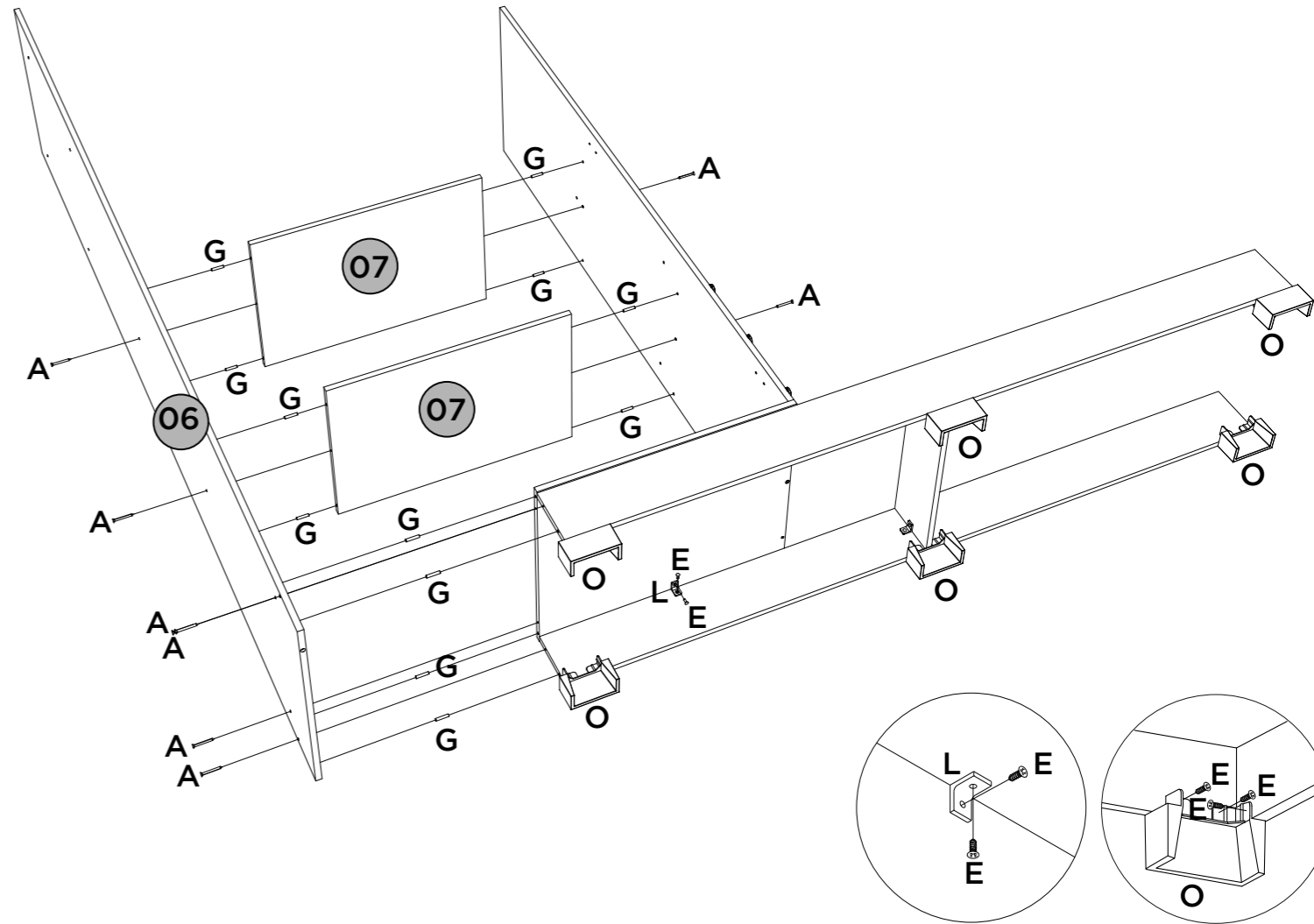
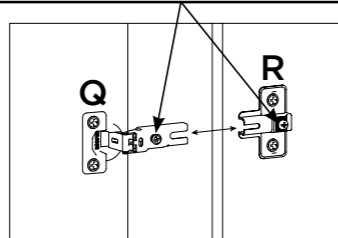

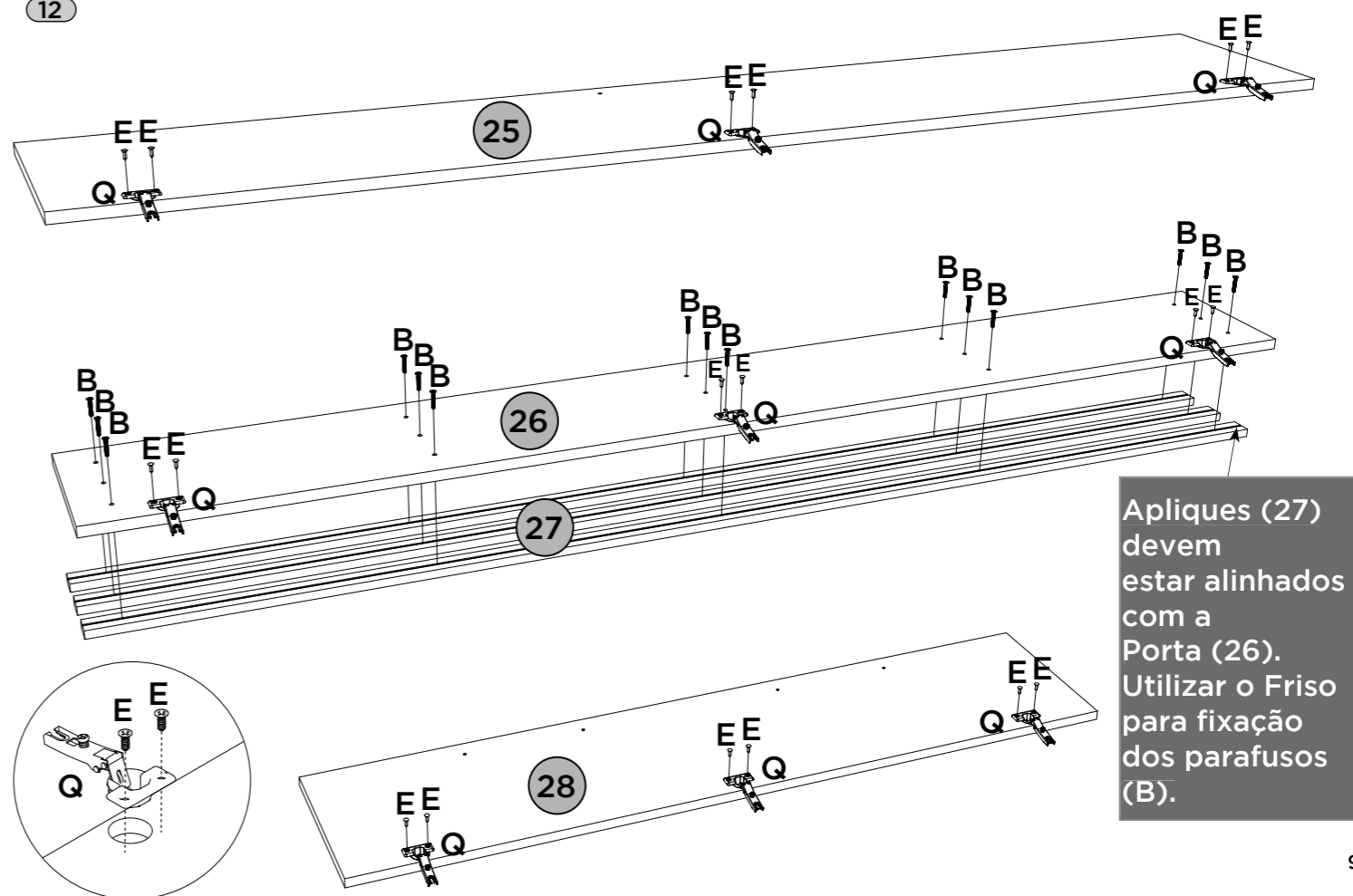
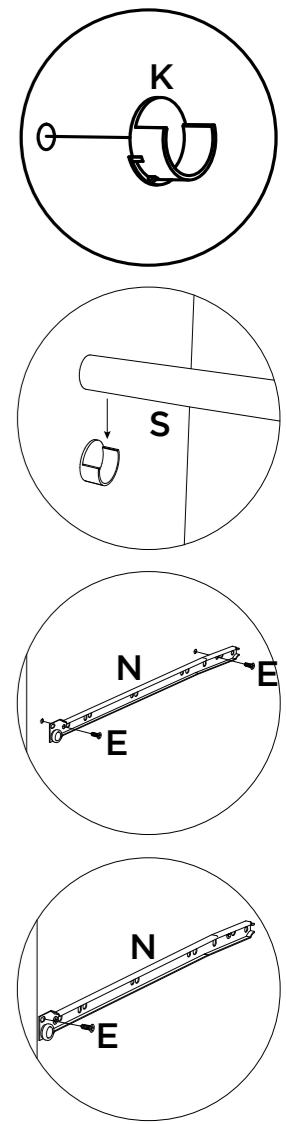
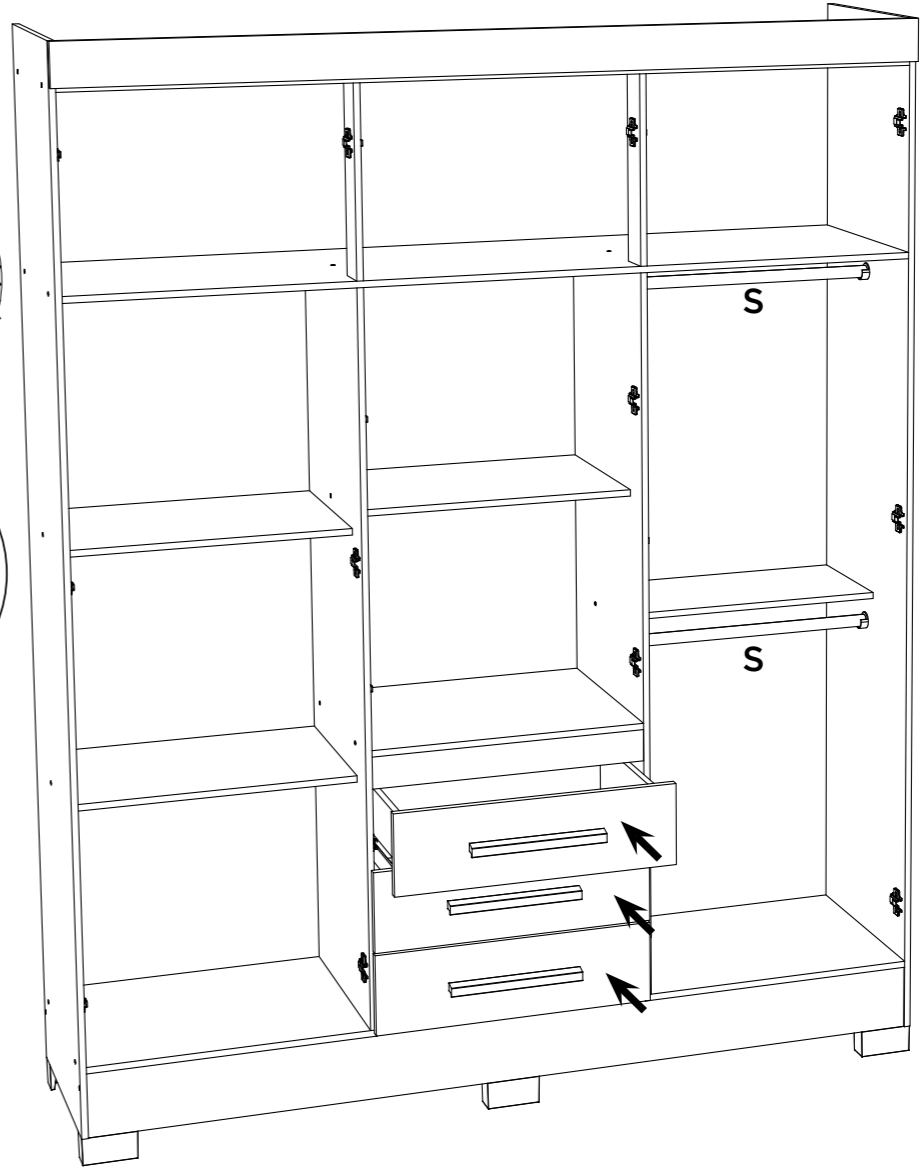
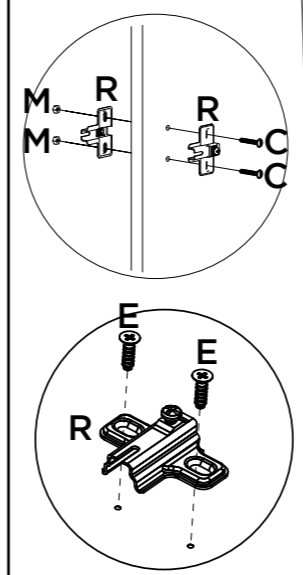
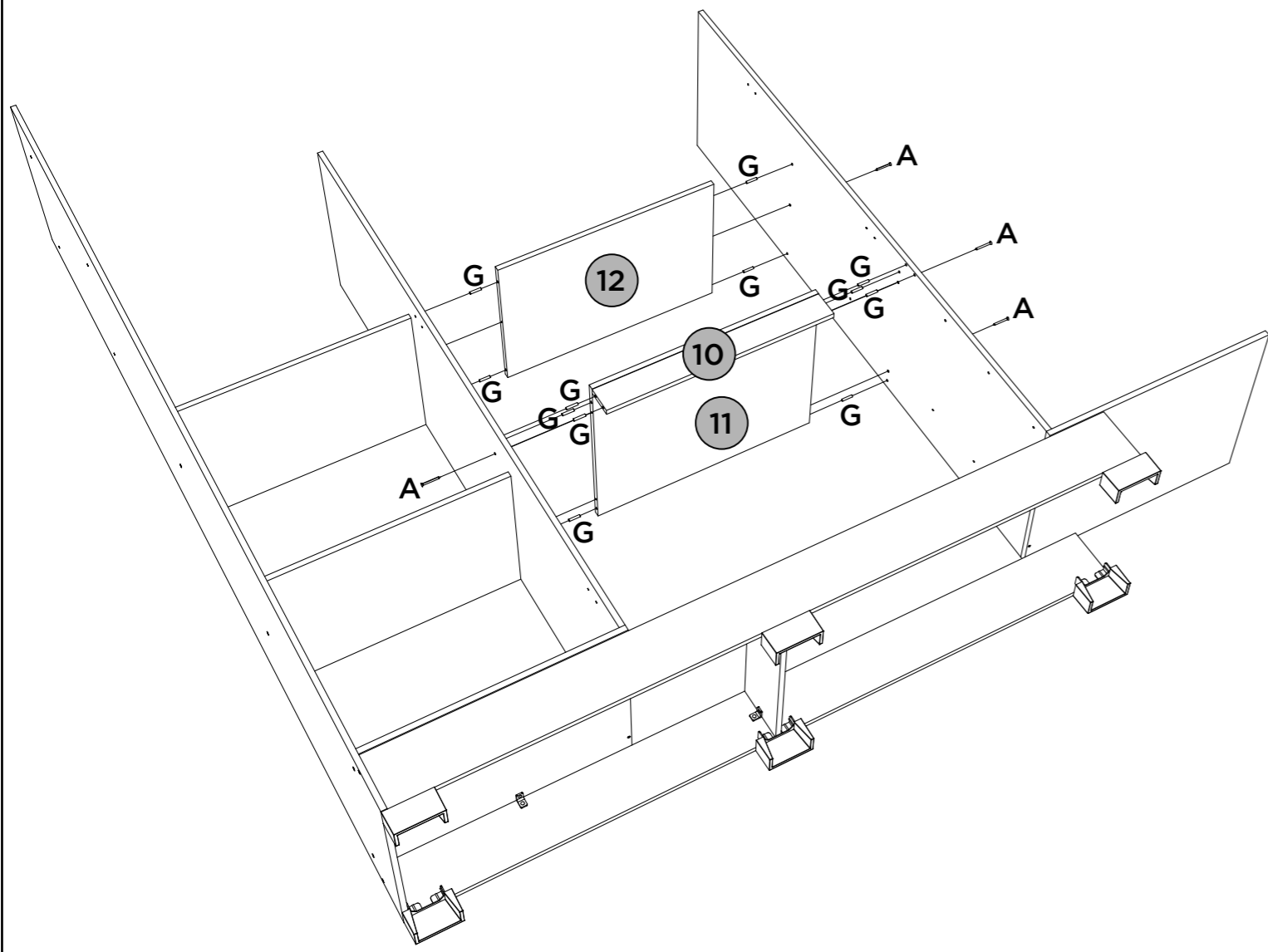

Apliques (27) devem estar alinhados com a Porta (26). Utilizar o Friso para fixação dos parafusos (B).

3X

1°

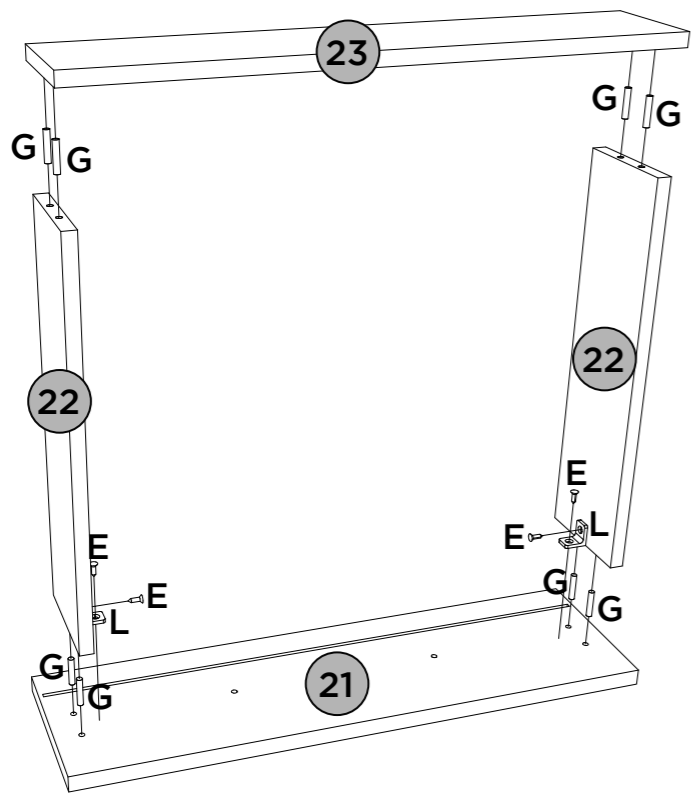

3X

2°

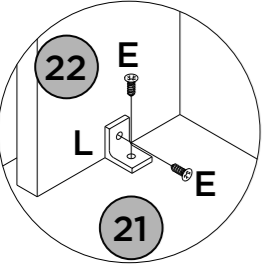
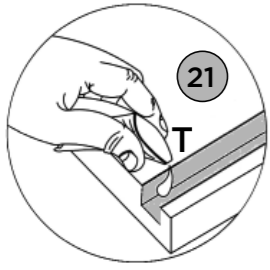
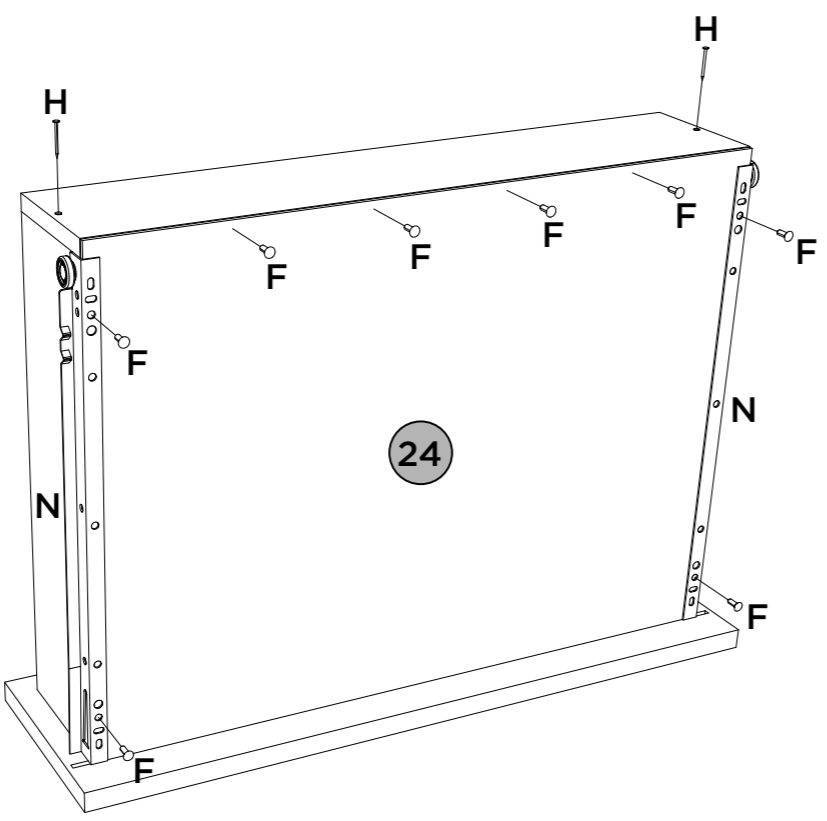

3X

3°

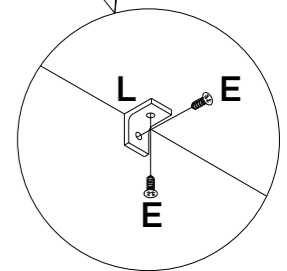
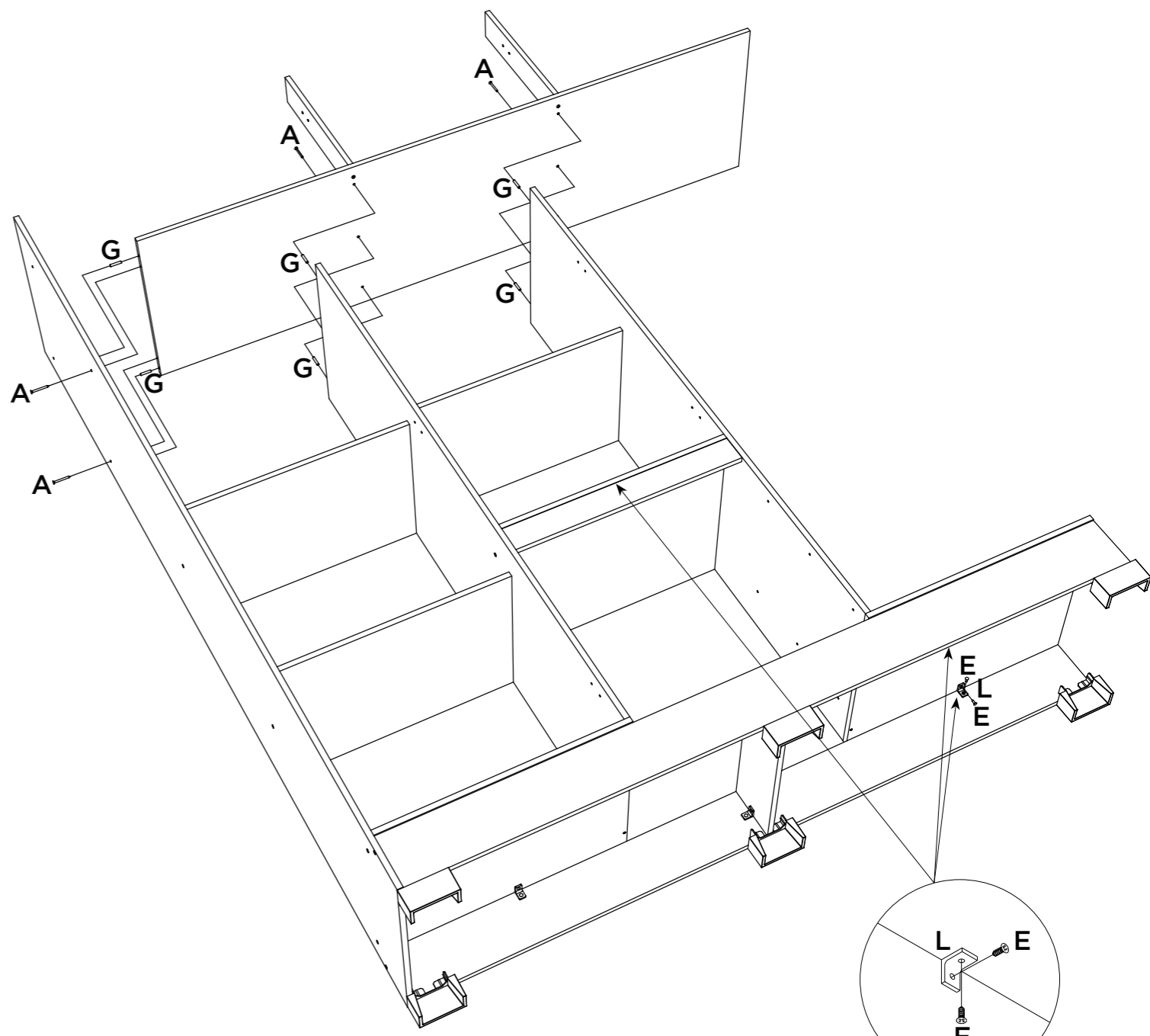
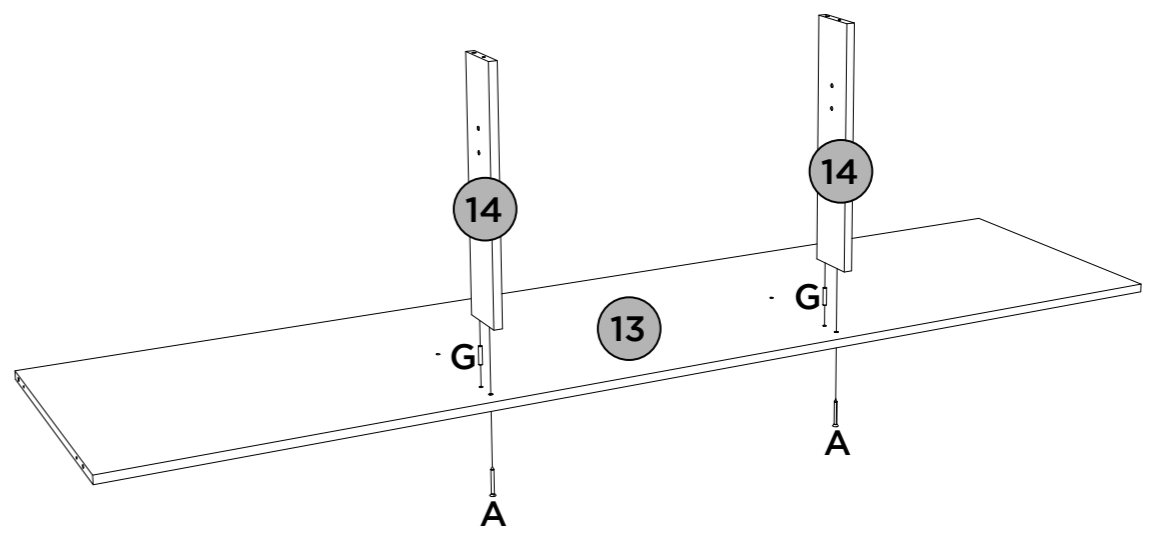
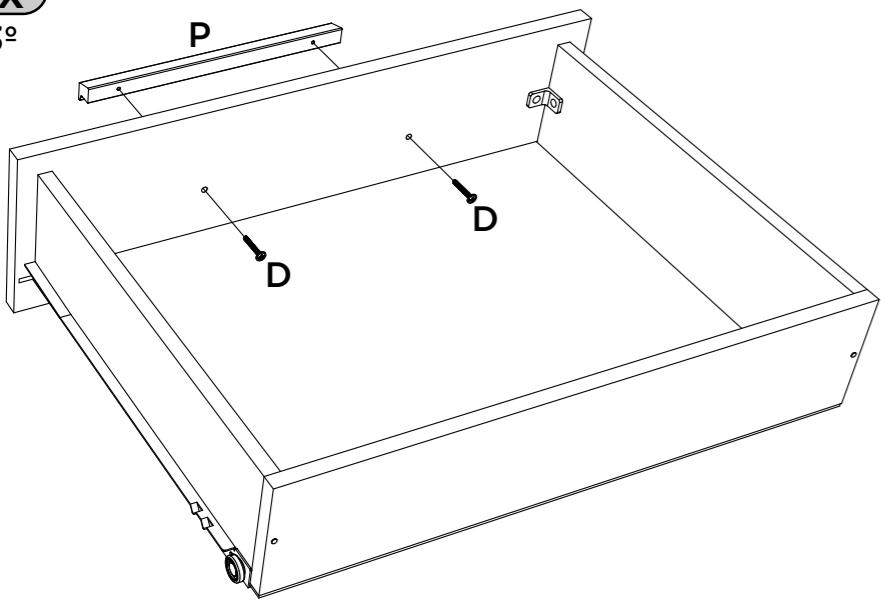

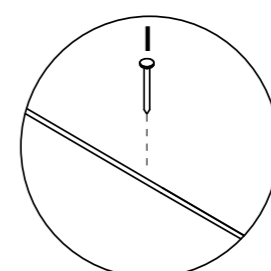
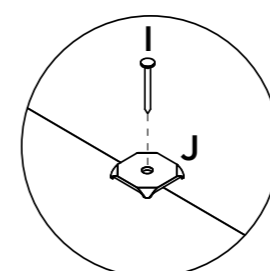
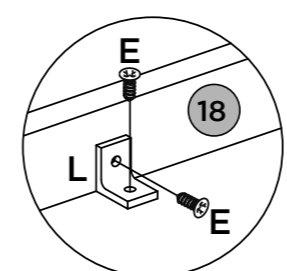
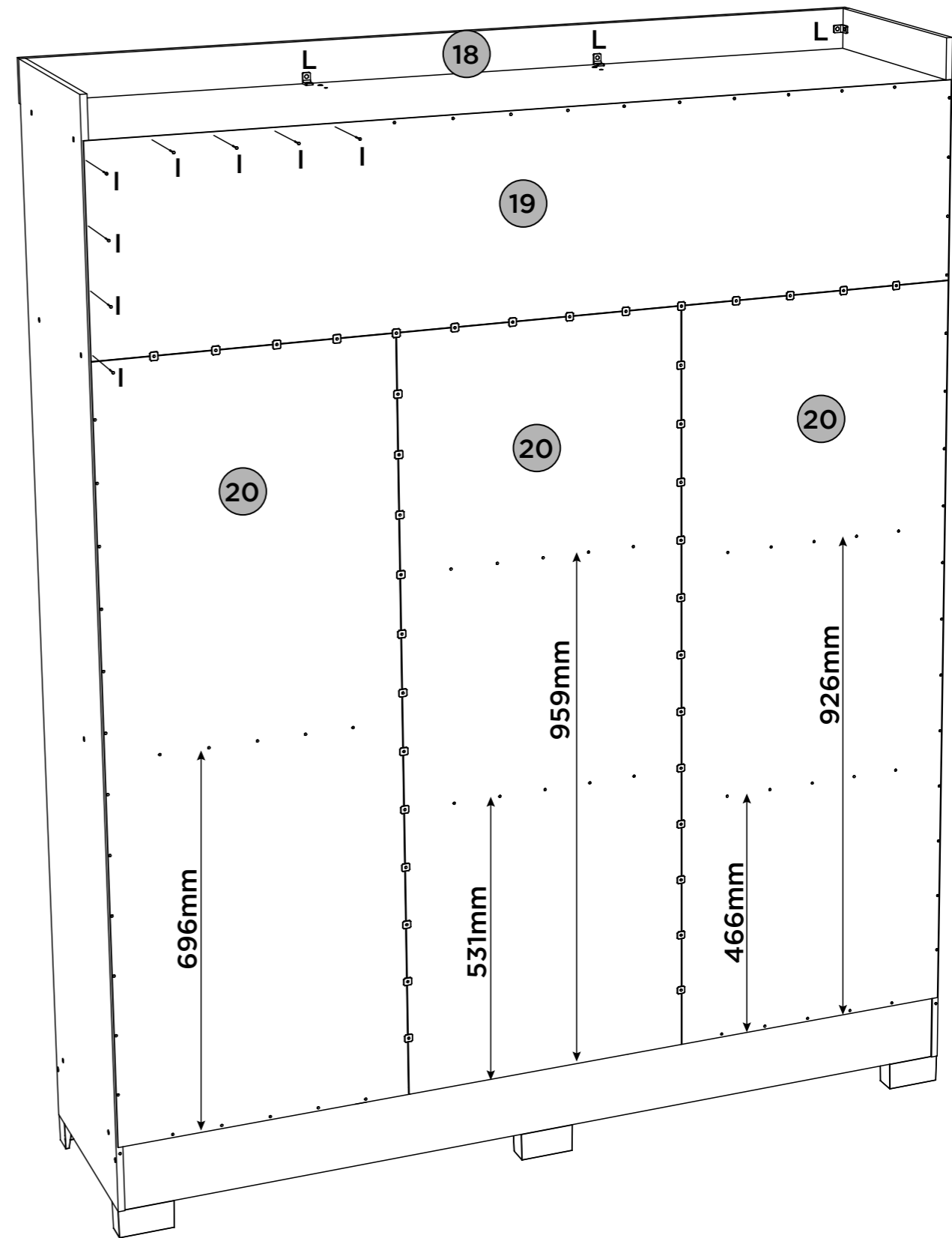
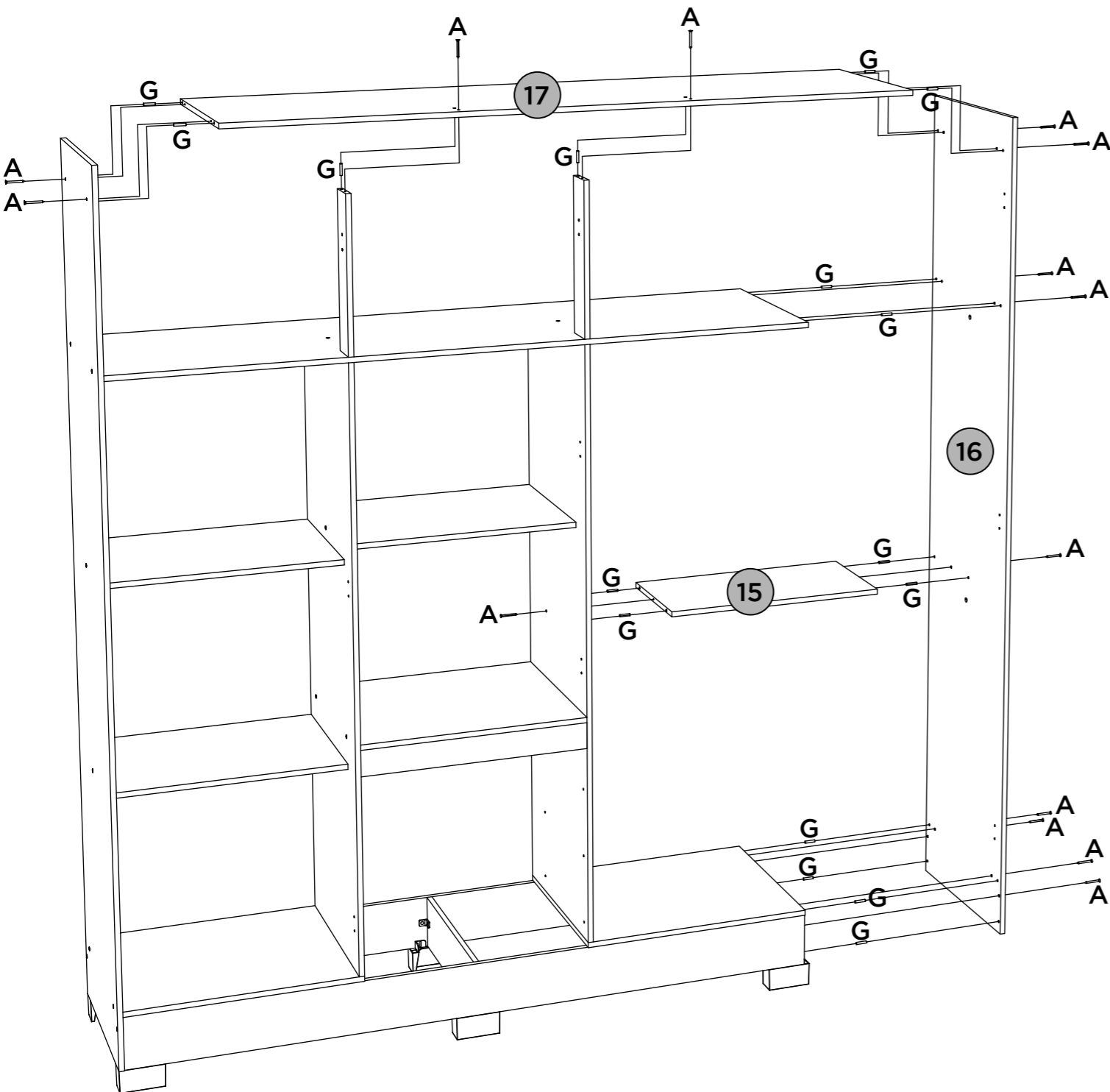

Fixar os pregos a uma distância de 120mm de um para outro.

Fijar las uñas a un distancia de 120 mm uno a otro.

Fix the nails at a distance of 120mm from one to the other