

GARANTIA / GARANTIA / WARRANTY

Nossos produtos são garantidos por 90 dias contra defeitos de fabricação. Ao constatar um problema coberto pela garantia, entre em contato com a loja onde o produto foi comprado. Ela estará capacitada para atendê-lo da melhor forma diante de cada caso. Reclamações de garantia somente poderão ser atendidas se o termo de garantia for apresentado no ato de reivindicação, acompanhado de sua nota fiscal de compra.

Nuestros productos están garantidos contra defectos de fabricación por 90 días, a partir de la compra. Ao constatar un problema protegido por la garantía, póngase en contacto con la tienda donde se adquirió el producto. Ella estará capacitada para atenderlo de la mejor manera de acuerdo con cada caso.

Our products are guaranteed against manufacturing defects for 90 days from the date of purchase. When you find a problem covered by the warranty, please contact the store where the product was purchased. The store be able to serve you in the best way in each case.

Exclusões

- Desgaste natural ou danos causados por água, maresia, ferrugem, incêndio, calor, cupins e pragas em geral.
- Montagem, manutenção e uso inadequado.
- Não cumprimento das recomendações técnicas do esquema.
- Montagens e desmontagens após a primeira instalação.
- Instalações elétricas e outras afins.

Exclusiones

- Desgaste natural o daños causados por agua, mares, maresia, incendios, calor, termitas y plagas en general.
- Montaje, mantenimiento y uso inadecuado.
- No cumplimiento de las recomendaciones técnicas del esquema.

Exclusions

- Natural wear or damage caused by water, sea, rust, fire, heat, termites and plagues in general.
- Assembly, maintenance and improper use.
- Failure to comply with the technical recommendations of the assembly instructions.

Importante

A não autoriza nenhuma pessoa, loja ou entidade assumir em seu nome qualquer outra garantia que não conste no certificado. O fabricante reserva-se no direito de efetuar nos produtos eventuais modificações que considerar necessárias, sem prejudicar as características essenciais. Os produtos terão peças de assistência para reposição no período de 1 ano a contar de sua retirada do mercado, desde que haja matéria-prima equivalente, observando o dispositivo no Art.32 da Lei 8.078/90 (Cód. Defesa do Consumidor). O atendimento para produtos fora de linha é feito por programação especial, através da loja revendedora sob aprovação de consulta prévia ao fabricante.

Importante

no autoriza a ninguna persona, tienda o entidad a asumir en su nombre cualquier otra garantía que no figure en el certificado. El fabricante se reserva el derecho de efectuar en los productos eventuales modificaciones que considere necesarias, sin perjudicar las características esenciales. Los productos tendrán piezas de asistencia para reposición en el período de 1 año a partir de su retirada del mercado. La atención para productos fuera de línea es hecha por programación especial, a través de la tienda revendedora bajo aprobación de consulta previa al fabricante.

Important

does not authorize any person, store or entity to assume on its behalf any other warranty that does not appear on the certificate. The manufacturer reserves the right to make in the products any modifications that it considers necessary without prejudice to the essential characteristics. The products will have replacement parts within one year of being withdrawn from the market. The service for off-line products is done by special programming, through the store reseller under prior consultation with the manufacturer.

INSTRUÇÕES DE LIMPEZA E CONSERVAÇÃO

INSTRUCCIONES PARA LA LIMPIEZA E CONSERVACION / CLEAN AND PRESERVATION INSTRUCTURE

Para retirar o pó, utilize um pano seco, espanador ou aspirador. Se necessário, para uma limpeza mais efetiva, utilize um pano levemente umedecido com água. Finalize com uma flanela limpa e seca.

Para eliminar el polvo, utilice un paño seco, mopa o la aspiradora. Si es necesario, para una limpieza más eficaz, utilice un paño ligeramente humedecido con agua. Terminar con un paño limpio y seco.

To take dirty, use a dry cloth, duster or vacuum. If necessary to take the dust, use a wet cloth. Finish with a clean and dry flannel.

IMPORTANTE / IMPORTANTE / IMPORTANT

 Não utilize produtos abrasivos como álcool e detergentes, como também esponjas rígidas ou palha de aço na limpeza dos móveis. No use limpiadores abrasivos como alcohol y detergentes, así como esponjas rígidas lana de acero para limpiar los muebles. Do not use abrasives such as alcohol and detergent, tough soaker also steel wool to clean the furniture.

 Proteja a superfície do móvel de objetos que transmitam calor ou umidade. Proteja la superficie del mueble de objetos que transmitan calor o humedad. Protect the surface of the furniture against objects that can pass heat and humidity.

 Evitar o contato de água e produto de limpeza com o rodapé do produto, pois poderá danificá-lo. Evitar el contacto con agua y producto de limpieza con el rodapé del producto, pues podrá dañarlo. Avoid the contact of water and cleaning products with baseboard, cause it should damage your product.

 Procure sempre utilizar flanela limpa e seca para a limpeza. Busque siempre utilizar flanela limpia y seca para la limpieza. Try always to use a clean and dry flannel to cleaning.

 Cuidado com objetos pontiagudos, eles podem arranhar a superfície das portas e tampo. Cuidado con objetos afilados, ellos pueden rayar la superficie de las puertas e la tapa. Take care with sharp objects, they can scratch the door lid surface.

Imagem Ilustrativa/ Illustrative Image/ Imagen Ilustrativa



Preste Atenção! ¡Preste atención! Attention!

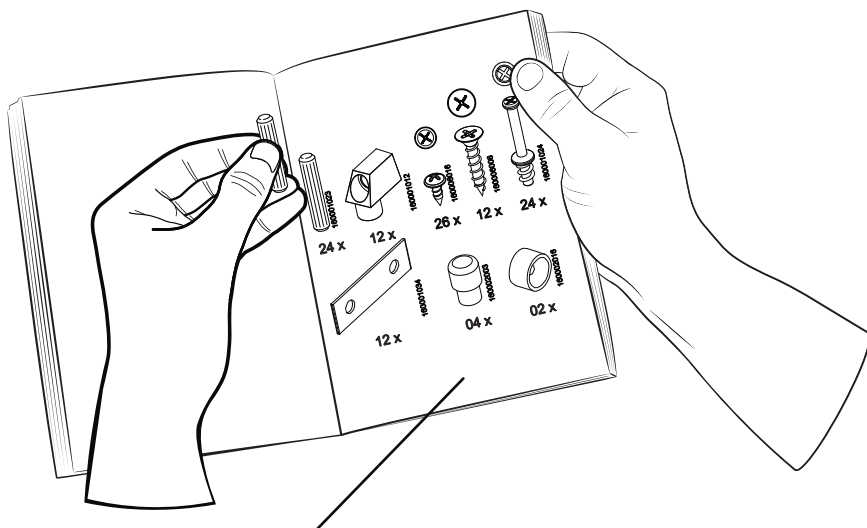

As ferragens dos nossos manuais são sempre apresentadas nas mesmas proporções da peça na vida real.
Caso apareça alguma dúvida no decorrer do processo de montagem, coloque a ferragem ao lado do desenho e faça a consulta :D

Los accesorios de nuestros manuales siempre se presentan en las mismas proporciones que la pieza en la vida real.
Si tiene alguna duda durante el proceso de montaje, coloque los accesorios junto al dibujo y haga una consulta :D

The accessories in our manuals are always presented in the same proportions as the spare part in real life.
If you have any questions during the assembly process, place the accessory next to the drawing and make an inquiry :D

Símbolos: Símbolos: Symbols:



- + Parafuso Phillips
- Parafuso Fenda
- ⊗ Parafuso Allen

- + Tomillo Philips
- Tomillo Ranurado
- ⊗ Tomillo Allen

- + Phillips screw
- Slotted Screw
- ⊗ Allenscrew

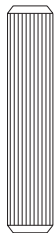

160001023

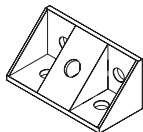

160001018

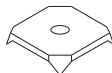

160001002



160001022

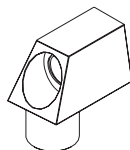

160001012

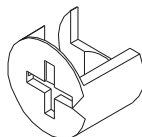

160001025

48 x

33x

08x

04x

06x

51x

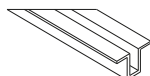

1600012025



160002003



160002012



160001016



160002002



160009006

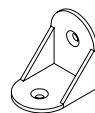

160001032

02x

04x

02x

08x

25x

08x

08x

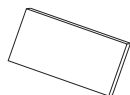

180001030



160002015

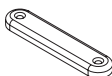

160002004

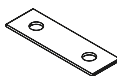

160001034

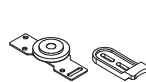

160003004



160010028

02x

08x

08x

28x

02x

01x



160002005

03x



160006010

04x

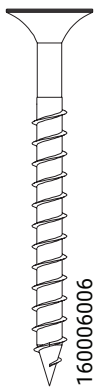

160006006

11x



160006008

06x



160006018

34x



160006016

208x



160006011

80x



160001024

51x

1:1

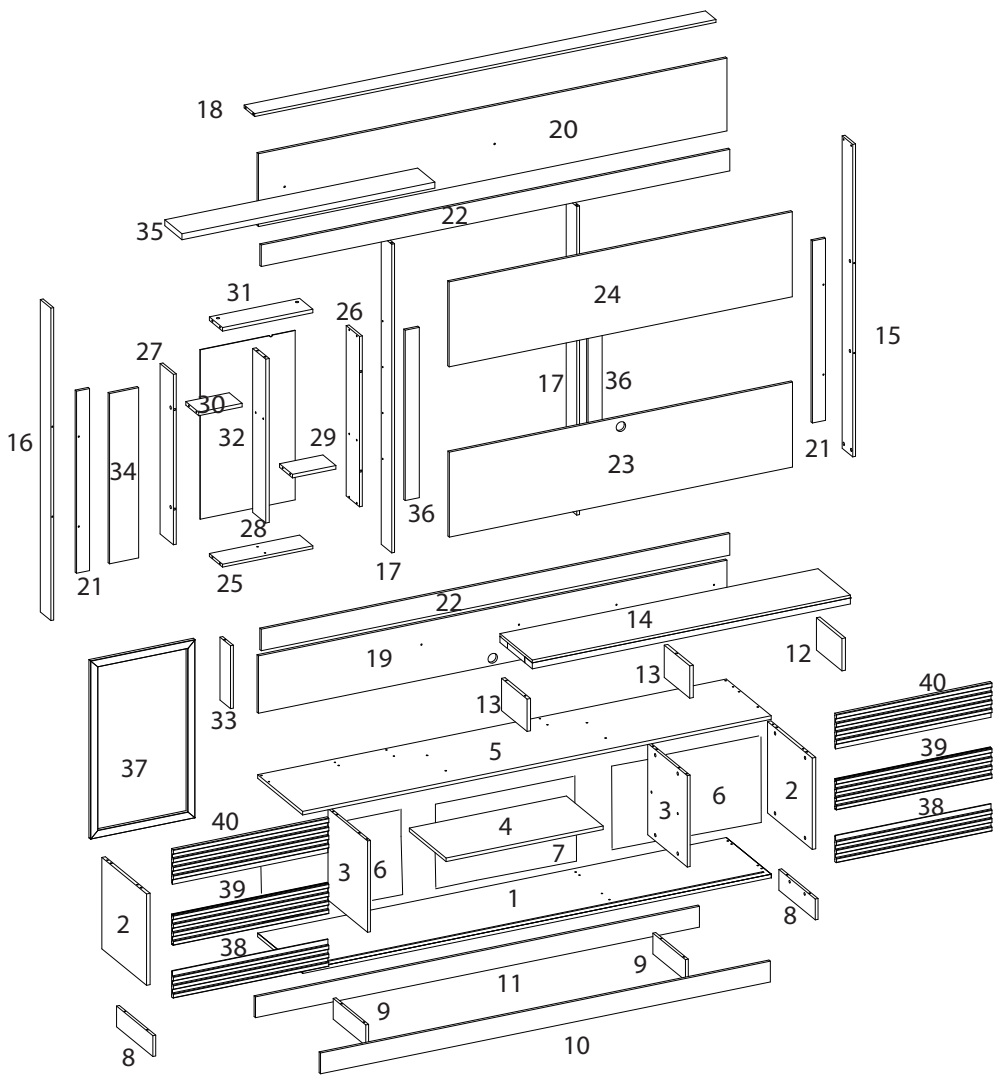

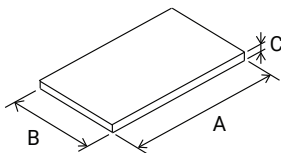

Volume	Peça	Código	Descrição	Comprimento	Largura	Espessura	Quantidade	Material
Caja	Artículo	Fleza	Descripción	A	Dimension	X	Lan	
Box	tem	Part	Description		B		The	
							amount	
1	1	510379001	BASE	2000	384	15	1	MDP
1	2	510379002	LATERAL INFERIOR	383	382	15	2	MDP
1	3	510379003	DIVISAO INFERIOR	382	338	12	2	MDP
2	4	510379004	PRATELEIRA MOVEL	670	314	15	1	MDP
1	5	510379005	TAMPO INFERIOR	2000	384	15	1	MDP
2	6	510379006	FUNDO LATERAL	653	407	2.8	2	MDF
2	7	510379007	FUNDO CENTRAL	682	407	2.8	1	MDF
2	8	510379008	RODAPE LATERAL	311	87	12	2	MDP
2	9	510379009	RODAPE CENTRAL	279	87	12	2	MDP
1	10	510379010	RODAPE FRONTAL	1920	87	12	1	MDP
1	11	510379011	RODAPE TRASEIRO	1894	87	12	1	MDP
1	12	510379012	DIVISAO DIREITA	218	135	15	1	MDP
1	13	510379013	DIVISAO CENTRAL/ESQUERDA	218	135	15	2	MDP
2	14	510379014	TAMPO TV	1358	277	37	1	MDP
1	15	510379015	TRAVESSA LATERAL DIREITA	1306	90	12	1	MDP
1	16	510379016	TRAVESSA LATERAL ESQUERDA	1306	90	12	1	MDP
1	17	510379017	TRAVESSA CENTRAL	1290	90	12	2	MDP
1	18	510379018	TRAVESSA SUPERIOR	1968	90	12	1	MDP
1	19	510379019	PAINEL INFERIOR	2000	240	12	1	MDP
1	20	510379020	PAINEL SUPERIOR	2000	305	12	1	MDP
1	21	510379021	TRAVESSA APOIO LATERAL	761	56	12	2	MDP
1	22	510379022	VISTA FRONTAL	2000	91	12	2	MDP
2	23	510379023	PAINEL INFERIOR TV	1465	356	12	1	MDP
2	24	510379024	PAINEL SUPERIOR TV	1465	356	12	1	MDP
2	25	510379025	BASE NICH0	385	113	12	1	MDP
2	26	510379026	LATERAL DIREITA NICH0	712	114	12	1	MDP
2	27	510379027	LATERAL ESQUERDA NICH0	712	114	12	1	MDP
1	28	510379028	DIVISAO NICH0	685	112	15	1	MDP
1	29	510379029	PRATELEIRA DIREITA NICH0	185	111	15	1	MDP
1	30	510379030	PRATELEIRA ESQUERDA NICH0	185	111	15	1	MDP
2	31	510379031	TAMPO NICH0	385	113	15	1	MDP
2	32	510379032	FUNDO NICH0	708	406	2.8	1	MDF
2	33	510379033	APOIO NICH0	263	90	12	1	MDP
2	34	510379034	PAINEL ESQUERDO	712	125	12	1	MDP
2	35	510379035	PRATELEIRA SUPERIOR	1080	147	25	1	MDP
1	36	510379036	TRAVESSA APOIO CENTRAL	712	60	12	2	MDP
2	37	510379037	QUADRO ENCABEÇAMENTO NICH0	745	446	15	1	MDF
1/2	38	510379038	MOLDURA INFERIOR PORTA	663	111	15	2	MDF
2	39	510379039	MOLDURA CENTRAL PORTA	663	126	15	2	MDF
2	40	510379040	MOLDURA SUPERIOR PORTA	663	147	15	2	MDF

Item	Description
1	BASIS
2	LOWER SIDE
3	LOWER DIVISION
4	MOBILE SHELF
5	LOWER TOP
6	SIDE BOTTOM
7	CENTRAL FUND
8	SIDE FOOTING
9	CENTRAL FOOTING
10	FRONT FOOTING
11	REAR FOOTER
12	RIGHT DIVISION
13	CENTER/LEFT DIVISION
14	TV TOP
15	RIGHT SIDE TRAVEL
16	LEFT SIDE TRAVEL
17	CENTER TRAY
18	TOP TRAY
19	BOTTOM PANEL
20	TOP PANEL
21	SIDE SUPPORT TRAY
22	FRONT VIEW
23	TV LOWER PANEL
24	TV TOP PANEL
25	NICHE BASE
26	NICHE RIGHT SIDE
27	NICHE LEFT SIDE
28	NICHE DIVISION
29	NICHE RIGHT SHELF
30	LEFT SHELF NICHE
31	NICHE TOP
32	NICHE FUND
33	NICHE SUPPORT
34	LEFT PANEL
35	TOP SHELF
36	CENTRAL SUPPORT PLATE
37	NICHE HEADER FRAME
38	LOWER DOOR FRAME
39	CENTRAL DOOR FRAME
40	DOOR TOP FRAME

Item	Description
1	BASE
2	LADO INFERIOR
3	DIVISION INFERIOR
4	ESTANTE MÓVIL
5	SUPERIOR INFERIOR
6	LATERAL FONDO
7	FONDO CENTRAL
8	PIE LATERAL
9	PIE CENTRAL
10	PIE DELANTERA
11	PIE TRASERO
12	DIVISION DERECHA
13	DIVISION CENTRO/IZQUIERDA
14	TV ARRIBA
15	RECORRIDO DEL LADO DERECHO
16	VIAJE DEL LADO IZQUIERDO
17	BANDEJA CENTRAL
18	BANDEJA SUPERIOR
19	PANEL INFERIOR
20	PANEL SUPERIOR
21	BANDEJA DE SOPORTE LATERAL
22	VISTA FRONTAL
23	PANEL INFERIOR DEL TELEVISOR
24	PANEL SUPERIOR DEL TELEVISOR
25	BASE DE NICHO
26	NICHO LADO DERECHO
27	NICHO LADO IZQUIERDO
28	DIVISION DE NICHO
29	NICHO ESTANTE DERECHO
30	NICHO ESTANTE IZQUIERDO
31	NICHO SUPERIOR
32	FONDO DE NICHO
33	SOPORTE DE NICHO
34	PANEL IZQUIERDO
35	ESTANTE SUPERIOR
36	PLACA DE SOPORTE CENTRAL
37	MARCO DE CABEZAL DE NICHO
38	MARCO DE LA PUERTA INFERIOR
39	MARCO DE PUERTA CENTRAL
40	MARCO SUPERIOR DE LA PUERTA

01

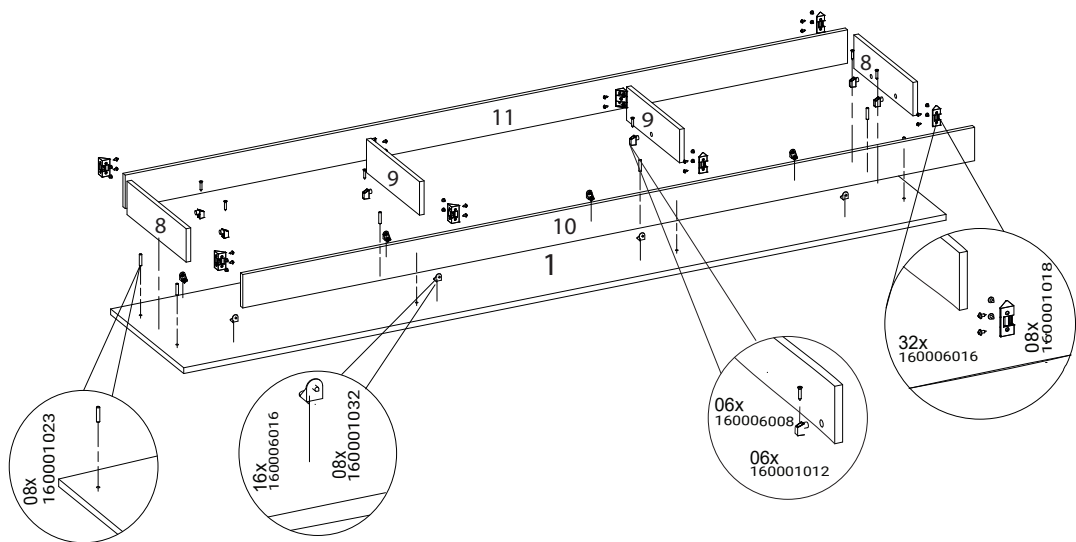
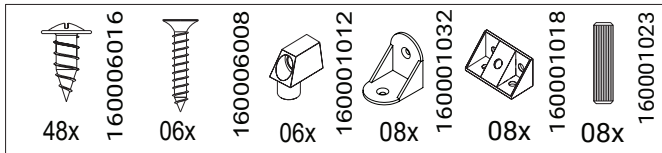

02

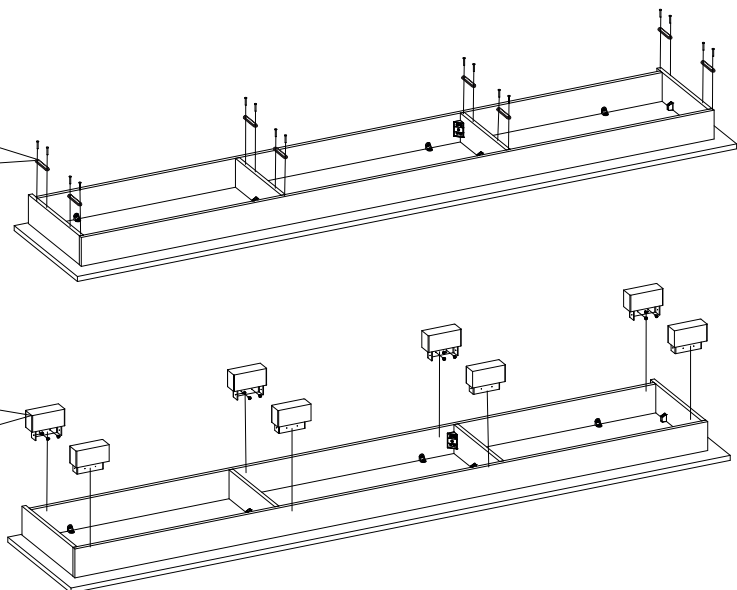
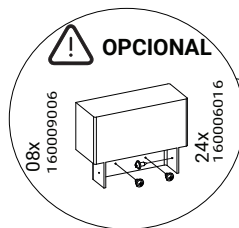
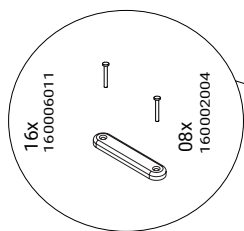
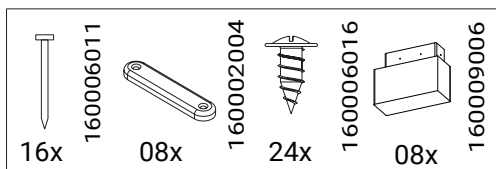

03

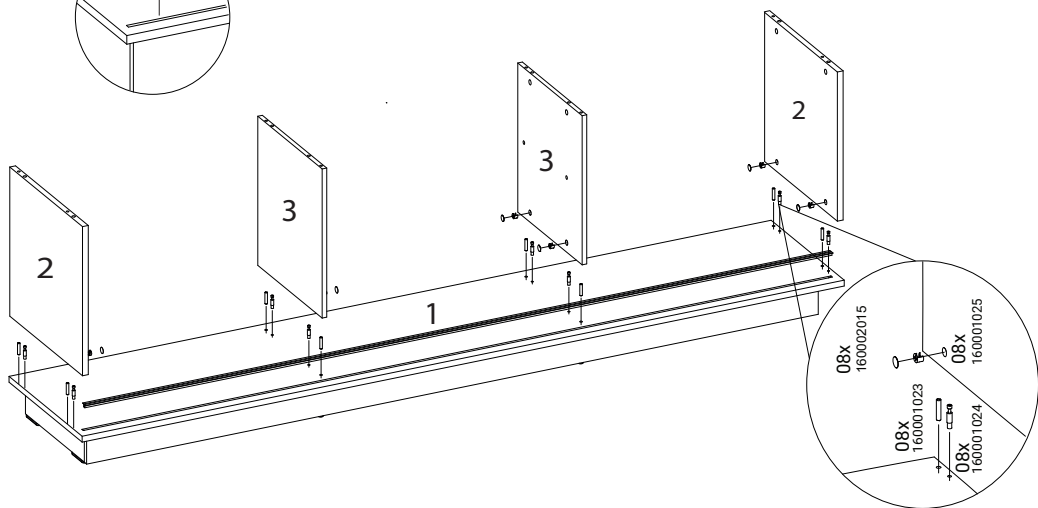
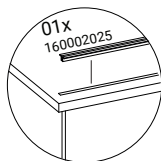
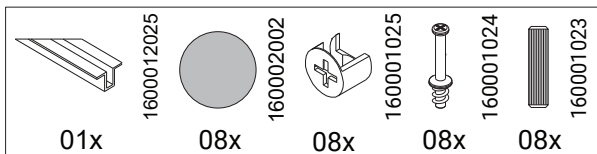

04

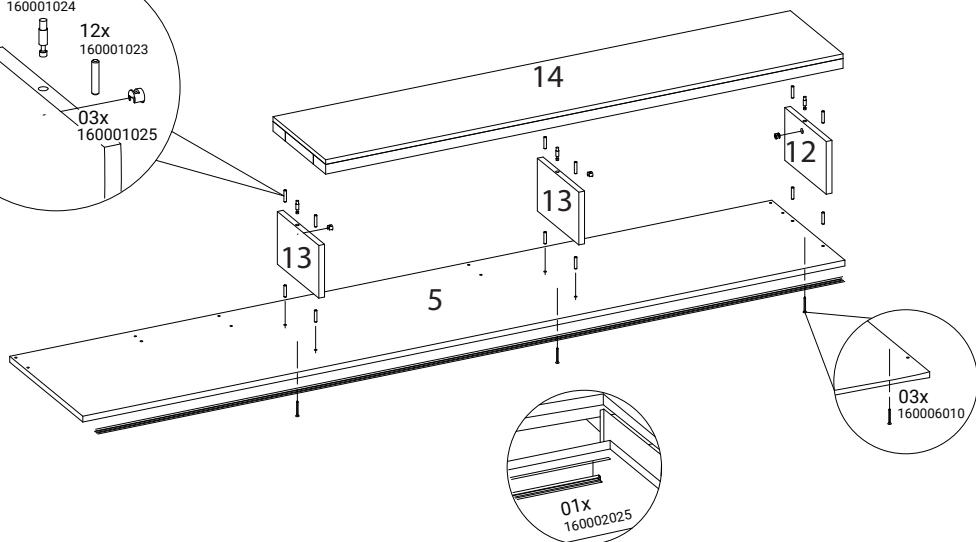
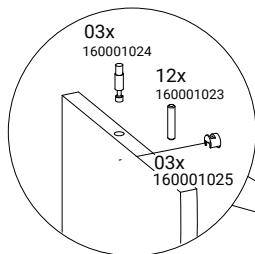
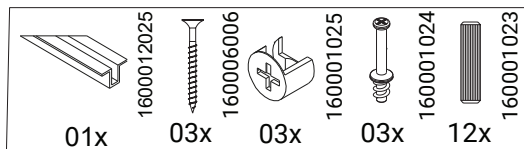

05

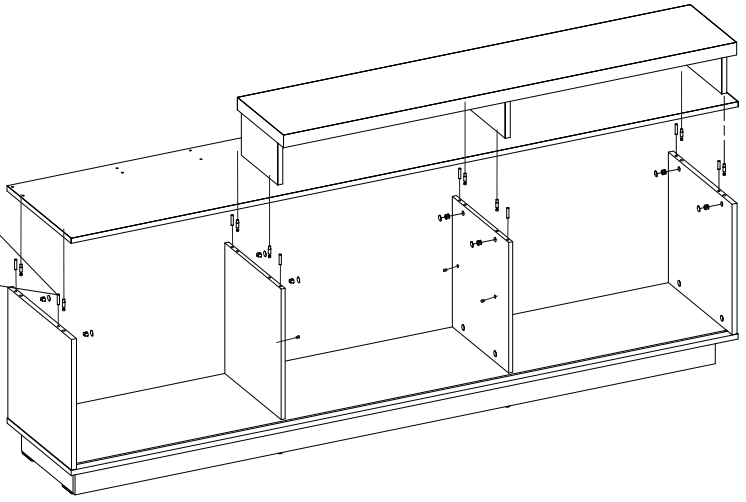
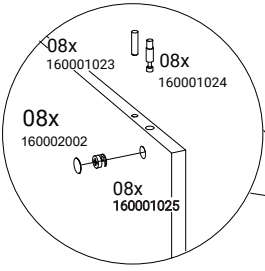
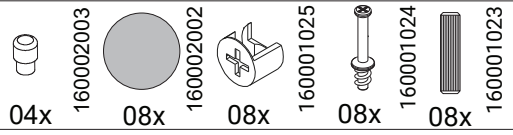

06

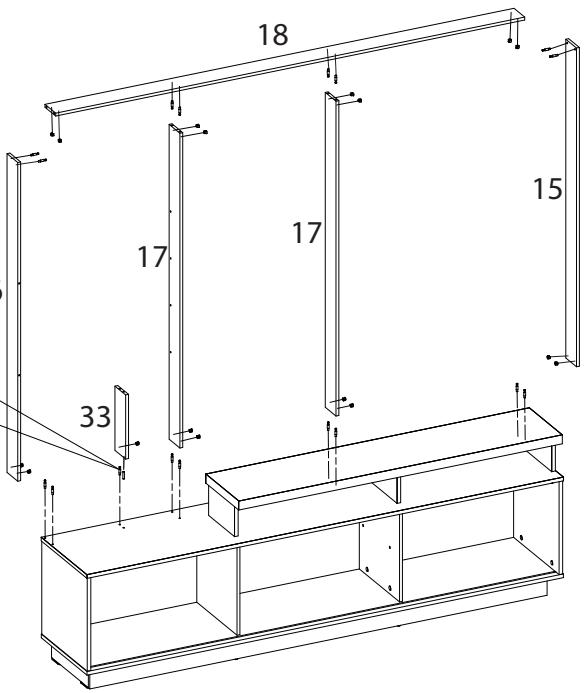
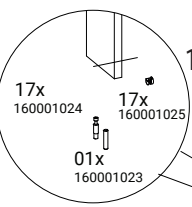
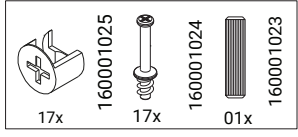

07

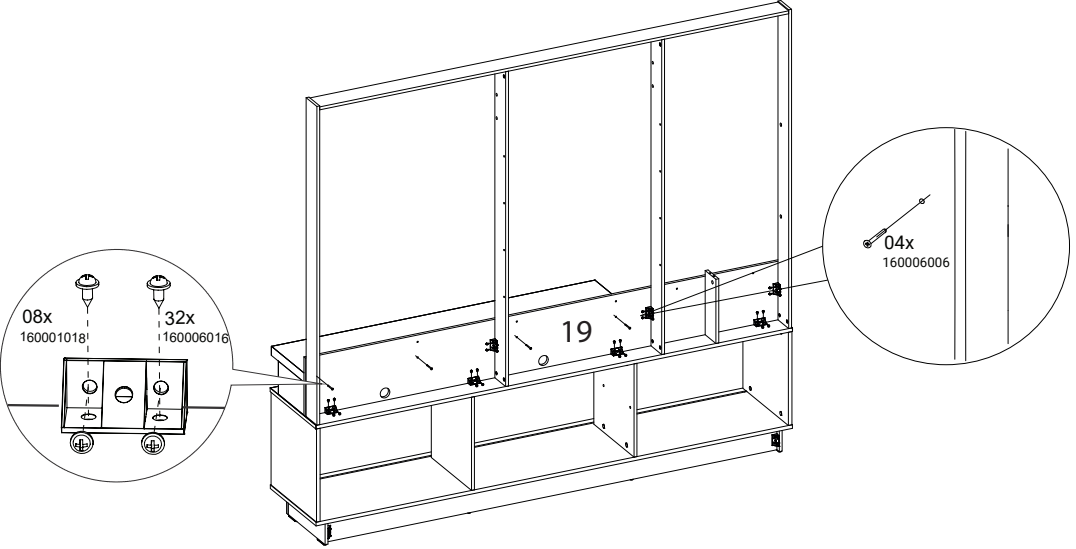
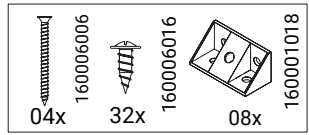

08

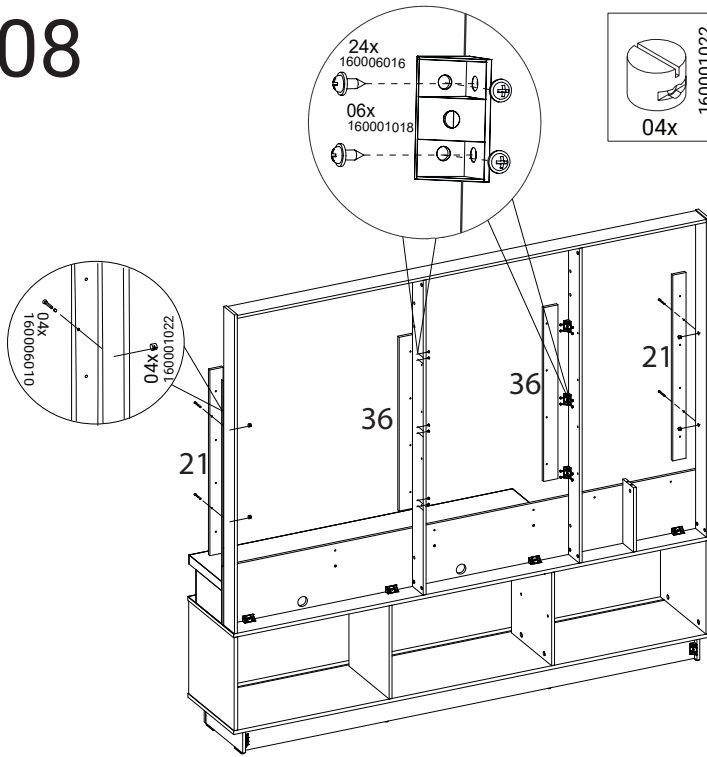
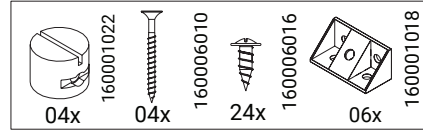

09

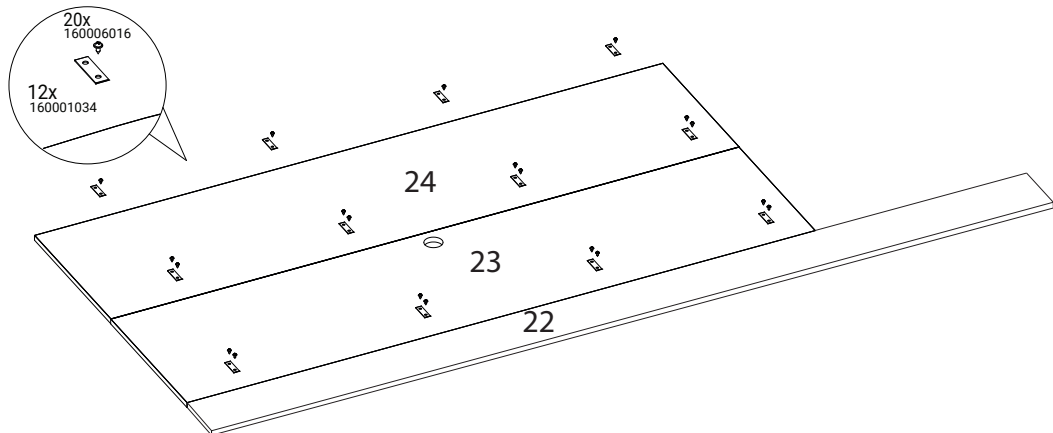
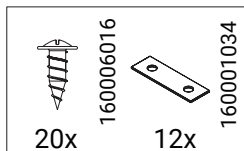

10

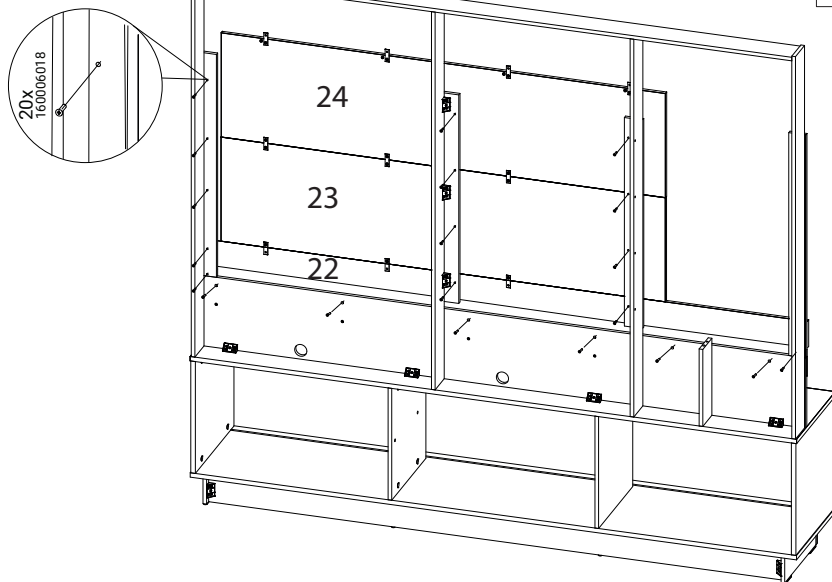
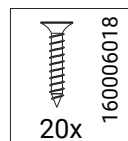

11

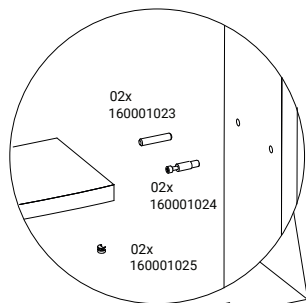

30

28

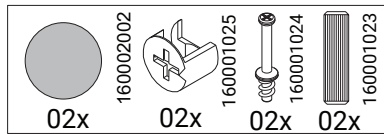

02x
160002002

02x
160001025

02x
160001024

02x
160001023

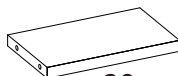

29

12

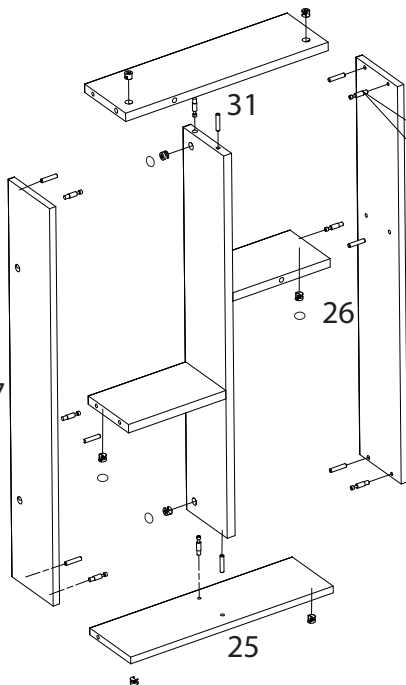

27

31

26

25

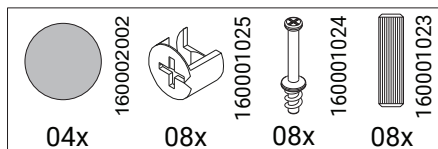

04x
160002002

08x
160001025

08x
160001024

08x
160001023

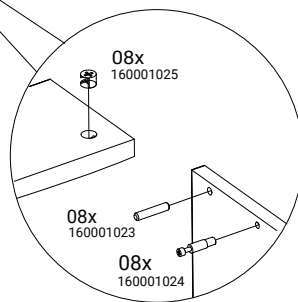

08x
160001025

08x
160001023

08x
160001024

13

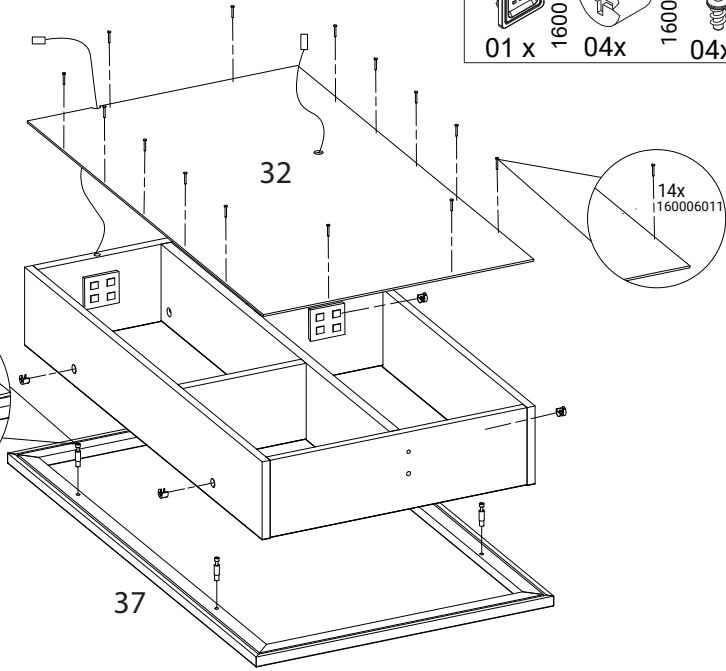
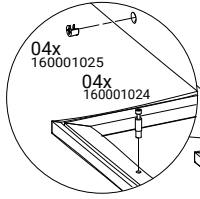
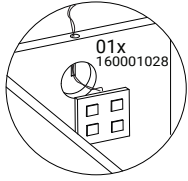

- 01 x 160001028
- 04 x 160001025
- 04 x 160001024
- 14 x 160006011

14

- 04 x 160006018
- 01 x 160001025
- 01 x 160001024
- 01 x 160001023

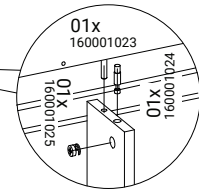
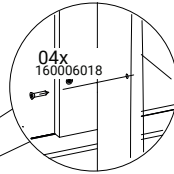
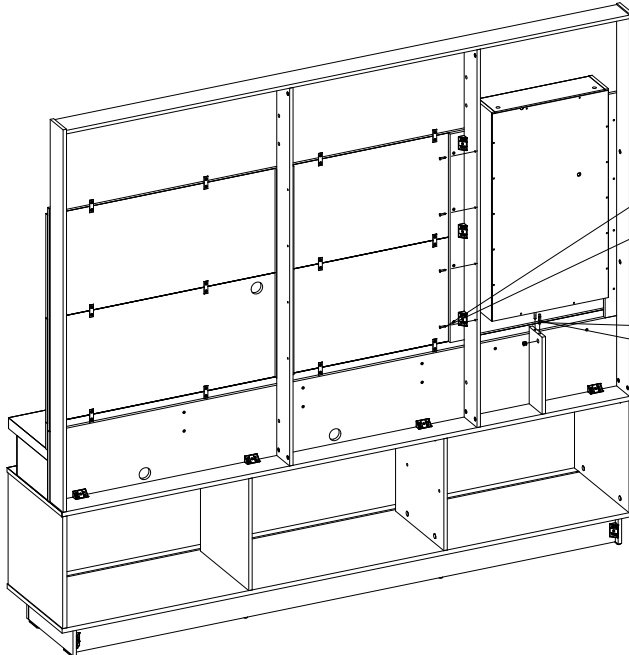

15

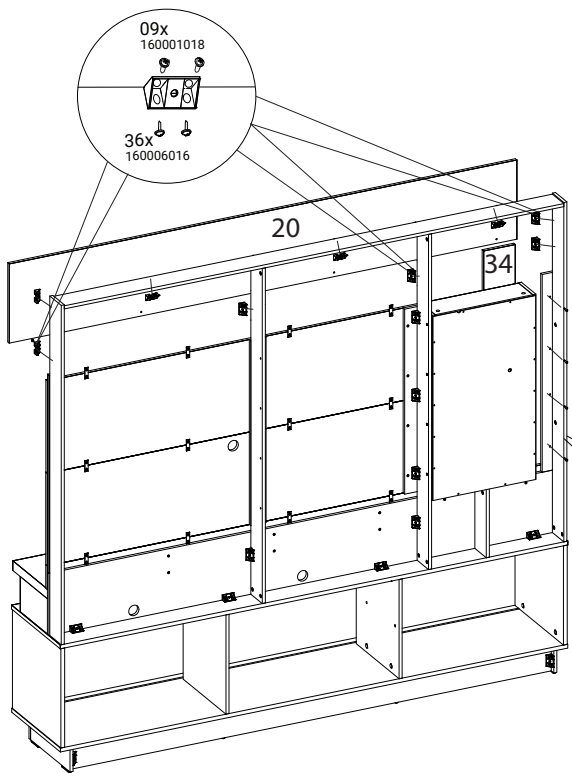

09x
160001018

36x
160006016

04x
160006018

36x
160006016

09x
160001018

04x
160006018

16

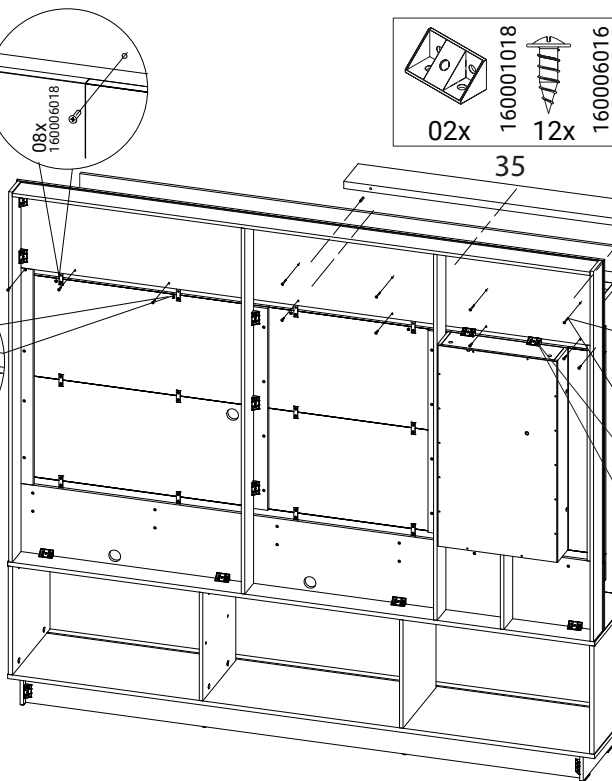

08x
160006018

02x
160001018

12x
160006016

08x
160006018

04x
160006006

02x
160001023

02x
160001023

04x
160006016

04x
160006006

08x
160006016

02x
160001018

17

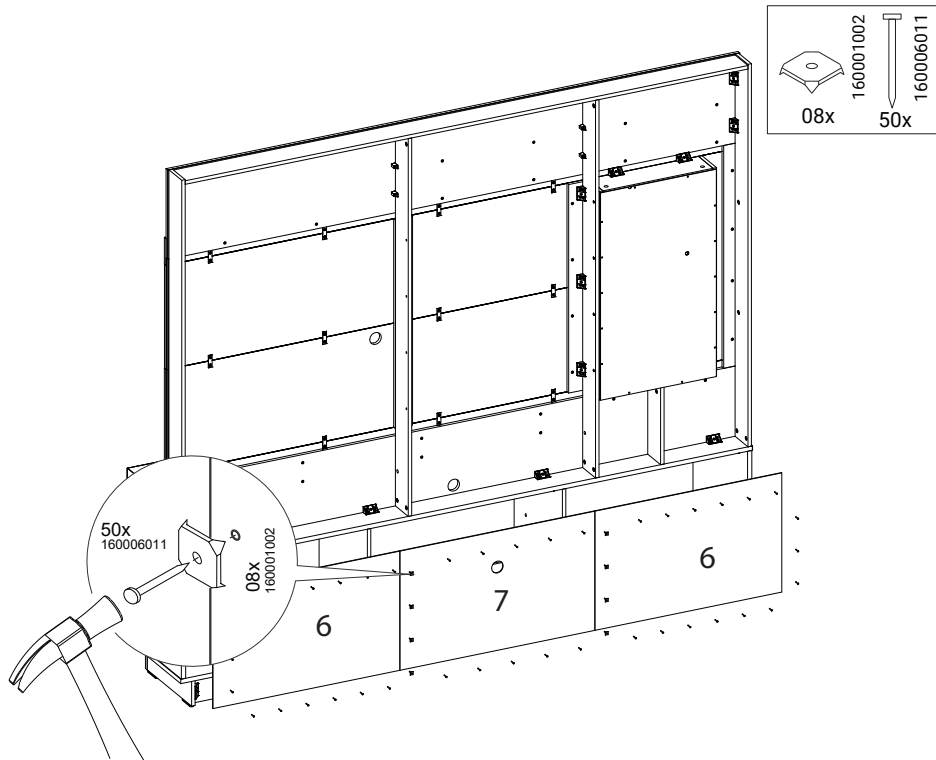

18

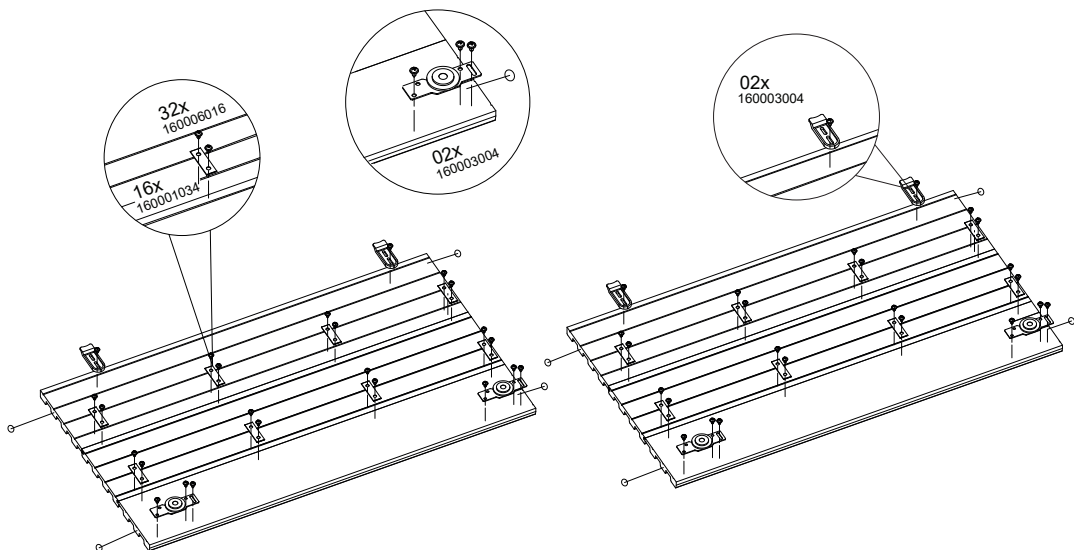
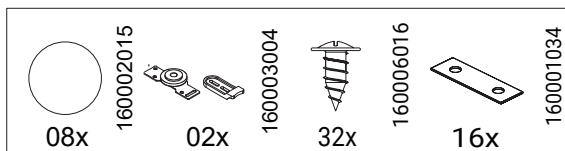

19

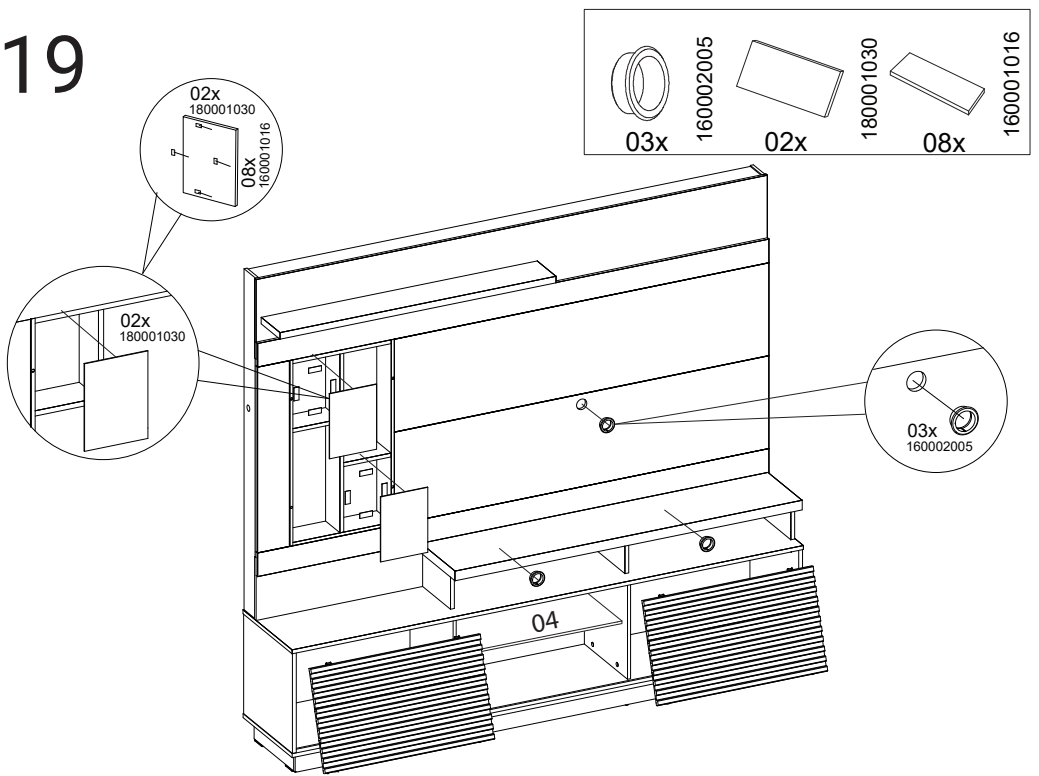

20

