

- Siga atentamente todas as instruções de montagem;
- Monte seu produto no local ou próximo de onde será colocado. Movimentações do produto já montado, podem avariá-lo;
- Faça a montagem em uma superfície limpa e plana. Aconselhamos usar a própria embalagem de papelão para forrar o chão;
- Verifique se as quantidades de peças e acessórios estão de acordo com o manual de montagem;
- Compare atentamente os furos de cada peça com a ilustração do manual;
- Utilize as ferramentas indicadas. Só utilize parafusadeira se tiver conhecimento e habilidade. O uso inapropriado pode danificar peças e/ou acessórios;
- Se o produto necessitar fixação na parede, tenha cuidado para não atingir fios e canos ao furar a parede.

**Obs:** Caso necessite solicitar peças de reposição, por favor, utilize os códigos dos mesmos.

- Siga con atención todas las instrucciones de armado.
- Arme su mueble en un lugar cerca donde será instalado. Mover el producto ya montado puede perjudicarlo.
- Haga el montaje en una superficie limpia y plana. Aconsejamos usar el propio embalaje de cartón para forrar el suelo.
- Asegúrese de que las cantidades de piezas y accesorios coincidan con el manual de montaje.
- Compare cuidadosamente los agujeros de cada pieza con la ilustración del manual.
- Utilice las herramientas indicadas. Sólo utilice atornillador automático si tiene conocimiento y habilidad. El uso inapropiado puede dañar piezas y/o accesorios.
- Si el producto necesita fijación en la pared, tenga cuidado de no alcanzar cables y tuberías al perforar la pared.

**OBS:** Si necesita solicitar piezas y / o accesorios de repuesto, por favor, utilice los códigos de los mismos.

- Follow carefully the assembly instructions.
- Assemble your furniture in a place near where it will be installed. Moving the assembled product can harm it.
- Make the assembly on a clean and flat surface. We recommend using the cardboard box to cover the floor.
- Make sure the quantities of parts and accessories match the assembly manual.
- Carefully compare the holes in each piece with the illustration in the manual.
- Use the indicated tools. Only use an automatic screwdriver if you have knowledge and skill. Improper use can damage parts and/or accessories.
- If the product needs fixing on the wall, be careful and don't reach cables and pipes when drilling the wall.

**NOTE:** If you need to request spare parts and/or accessories, please use the codes according of this instruction manual.

## CONSERVAÇÃO E LIMPEZA

MANTENIMIENTO Y LIMPIEZA / MAINTENANCE AND CLEANING

Não expor o produto ao sol, altas temperaturas e umidade, mantendo-o em local seco e arejado. Para a limpeza, utilizar um pano seco e macio. Não é necessário o uso de materiais abrasivos ou álcool.

*No exponga el producto al sol, altas temperaturas y la humedad. Mantener en local seco y ventilado. Para limpiar, utilice un paño suave y seco. No es necesario el uso de materiales abrasivos o alcohol.*

*Do not expose the product to sunlight, high temperatures and humidity. Keep it in a dry and ventilated place. To clean it, use a soft and dry cloth. It is not necessary to use abrasive materials or alcohol.*

## Garantia

Este certificado de Garantia é uma vantagem adicional oferecida ao consumidor, porém para que o mesmo tenha validade é imprescindível que seja apresentada a NOTA FISCAL de compra do produto e o número do lote (ver etiqueta).

Com este produto, a \_\_\_\_\_ tem como objetivo atender plenamente o proprietário-consumidor, proporcionando a garantia na forma aqui estabelecida, pelo período de 2 anos a partir da data da nota fiscal de compra. A \_\_\_\_\_ restringe a sua responsabilidade à substituição gratuita das peças defeituosas, em caso de defeitos ou avarias devidamente constatados como sendo de fabricação, durante a vigência desta garantia.

\_\_\_\_\_ declara a garantia nula e sem efeito se o produto for alterado, adulterado, molhado ou consertado e ainda pela prática de montagem inadequada. Também será considerada nula em casos de força maior, como aqueles causados por agentes da Natureza (chuvas, incêndios, excesso de umidade...).

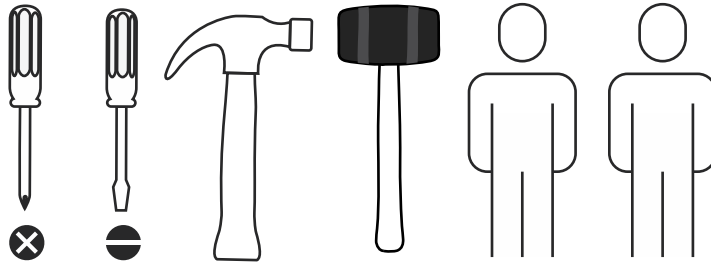

Para exercer seus direitos de comprador é importante que antes de montar seu produto você leia com atenção as instruções de cada passo do manual de montagem que acompanha o móvel.



**Dificuldade | Dificultad | Difficulty**

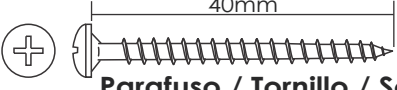
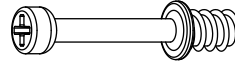
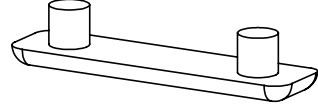
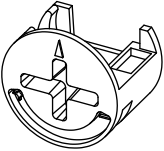
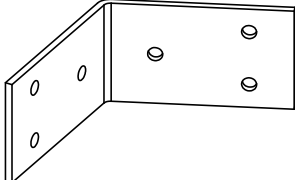
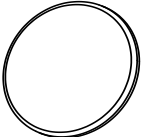

**Lista de materiais | Lista de materiales | Hardware list**

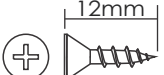
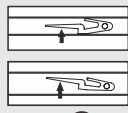
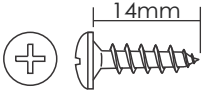
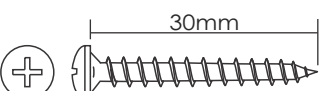
A	1:1 	Cavilha Tarugo Dowel Ø6x30mm	16	H	1:1 	Parafuso / Tornillo / Screw Ø3,5x40mm CP	08
B	1:1 	Minifix Minifix Minifix Ø7x30mm	04	I		Sapata Pata Foot	04
C	1:1 	Tambor Tambor Minifix cam Ø15x12mm	04	J		Cantoneira Cantonera Corner brace 115°	04
D	1:1 	Tapa furo adesivo Adhesivo Hole cover Ø18mm	04	K		Corrediça telescópica Corrediza telescópica Telescopic slide 350mm	02
E	1:1 	Parafuso Tornillo Screw Ø3,5x12mm CC	12	<div style="border: 1px solid black; padding: 5px;"> <p>.1</p>  <p style="text-align: center;">K</p> <p style="text-align: right;"><b>2x</b></p> </div>			
F	1:1 	Parafuso Tornillo Screw Ø4,0x14mm CP	24				
G	1:1 	Parafuso Tornillo Screw Ø4,0x30mm CP	07				

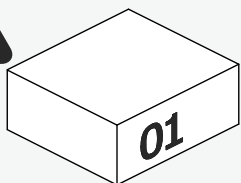

O número na borda da peça corresponde ao manual.  
Para remover, use um pano com álcool em gel ou álcool 70%.

El número que aparece en el borde de la pieza corresponde al manual.  
Para retirarlo, utilice un paño con alcohol en gel o alcohol al 70%.

The number on the edge of the piece corresponds to the assembly guide.  
To remove it, use a cloth with alcohol gel or 70% alcohol.

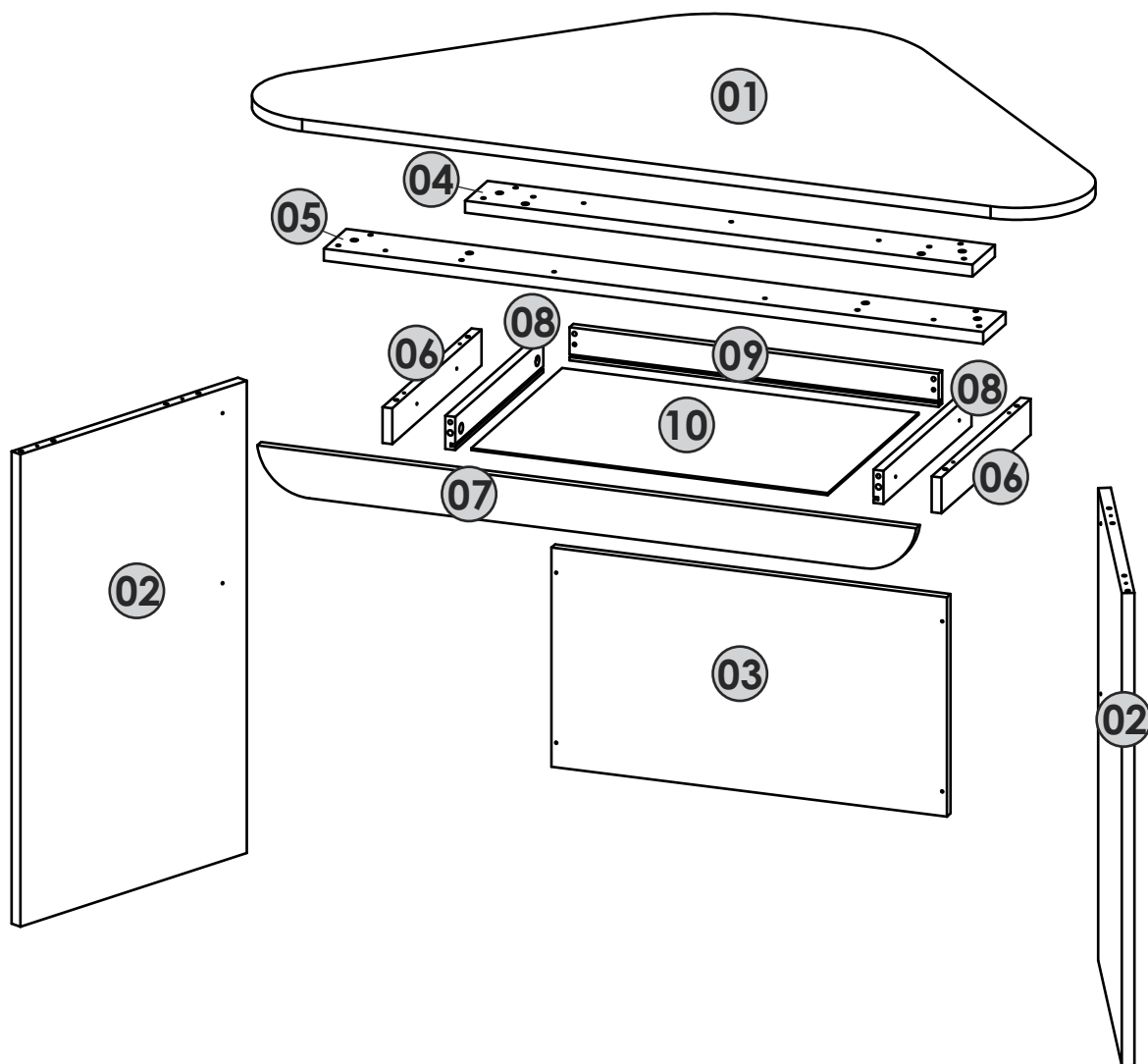

Item	Descrição   Description   Description			Dimensões Dimensiones   Dimensions mm			Qty Ctd Qty	Volume Volumen Volume
	Português	Español	English	Comp. Largo Length	Larg. Ancho Width	Esp. Grosor Thickness		
01	Tampo	Tapa	Top	1265	640	18	1	1/1
02	Lateral mesa	Lateral mesa	Side table	711	449	18	2	1/1
03	Travessa	Travesaño	Crosspiece	600	330	15	1	1/1
04	Apoio menor	Soporte más pequeño	Smaller support	90	770	18	1	1/1
05	Apoio	Soporte	Support	90	1001	18	1	1/1
06	Lateral gaveteiro	Lado cajonera	Drawer cabinet side	358	54	15	2	1/1
07	Frente gaveta	Frente cajón	Drawer front	1000	73	15	1	1/1
08	Lateral gaveta	Lado cajón	Drawer side	354	50	15	2	1/1
09	Traseira gaveta	Trasero del cajón	Drawer back	560	50	15	1	1/1
10	Fundo gaveta	Fundo del cajón	Drawer bottom	541	365	3	1	1/1

# 01

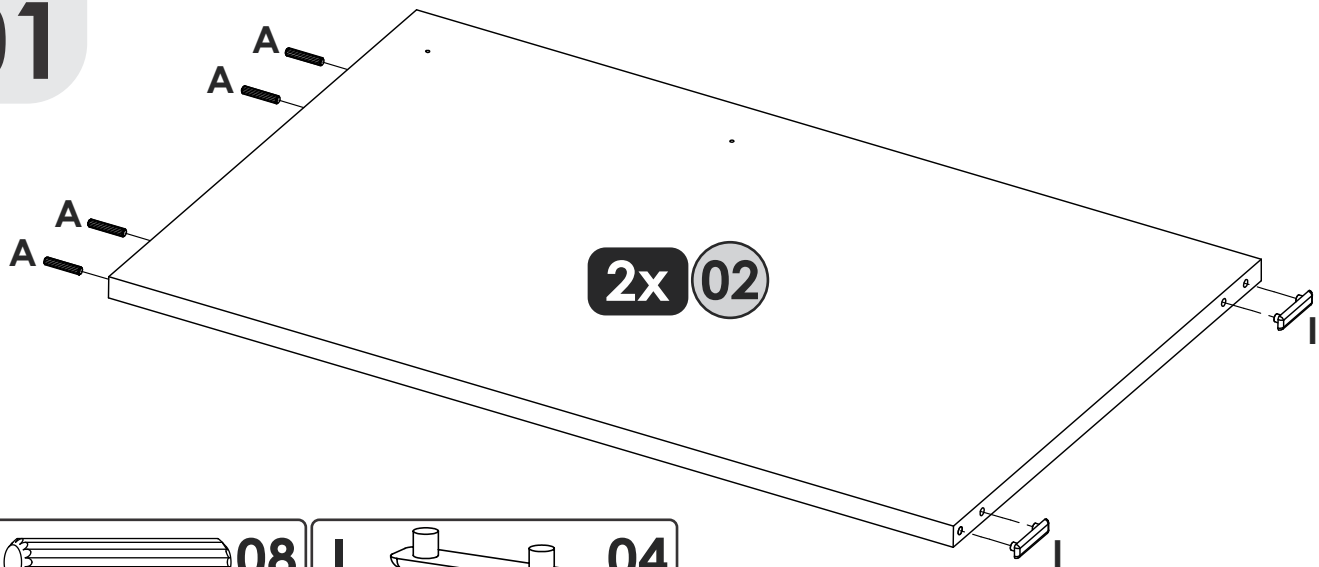

2x 02

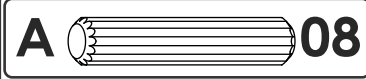

08

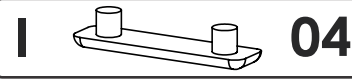

04

# 02

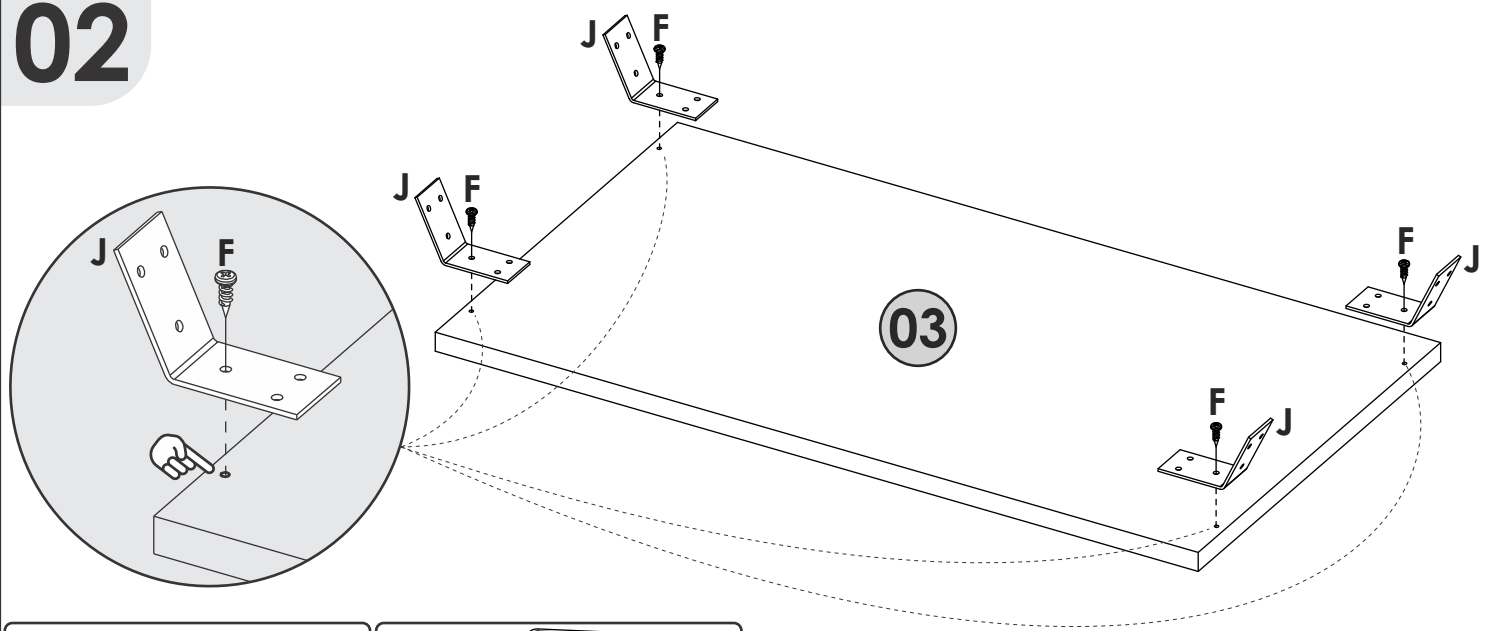

03

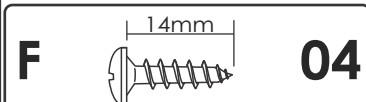

14mm

04

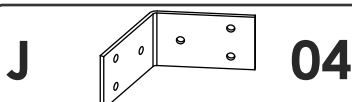

04

# 03

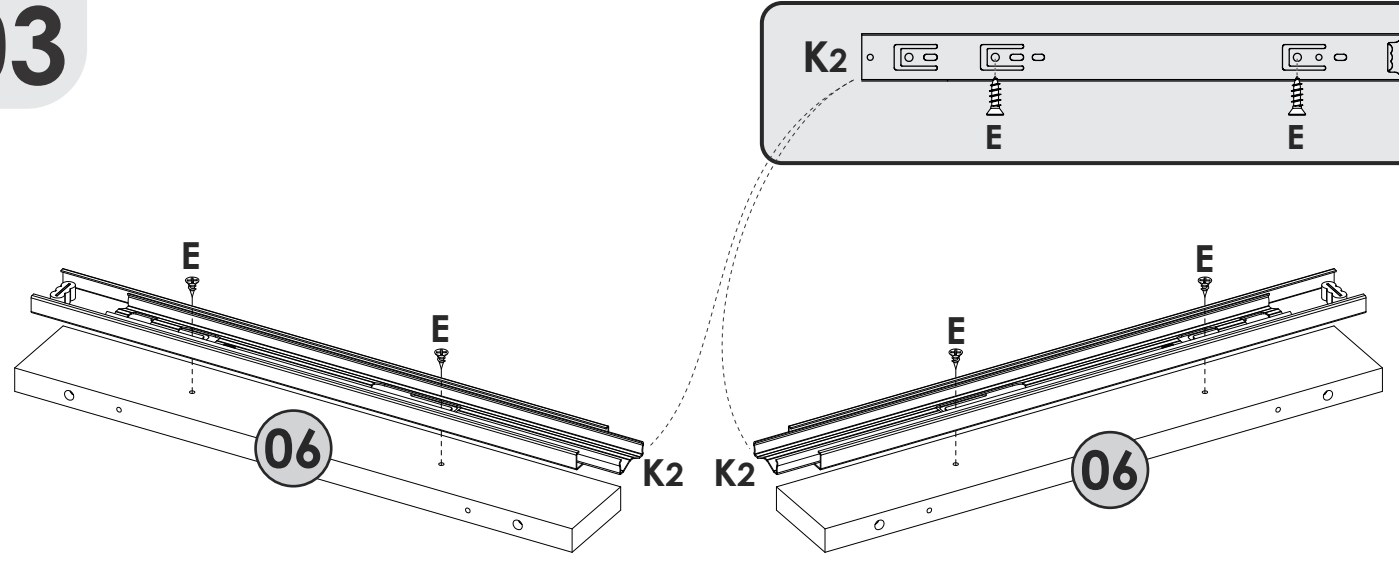

K2

E

E

06

K2

K2

06

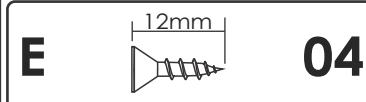

12mm

04



02

# 04

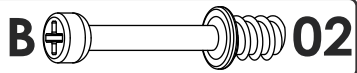
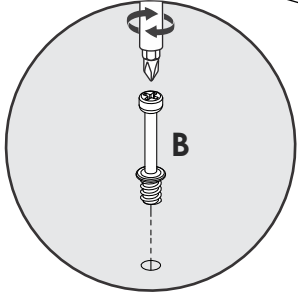
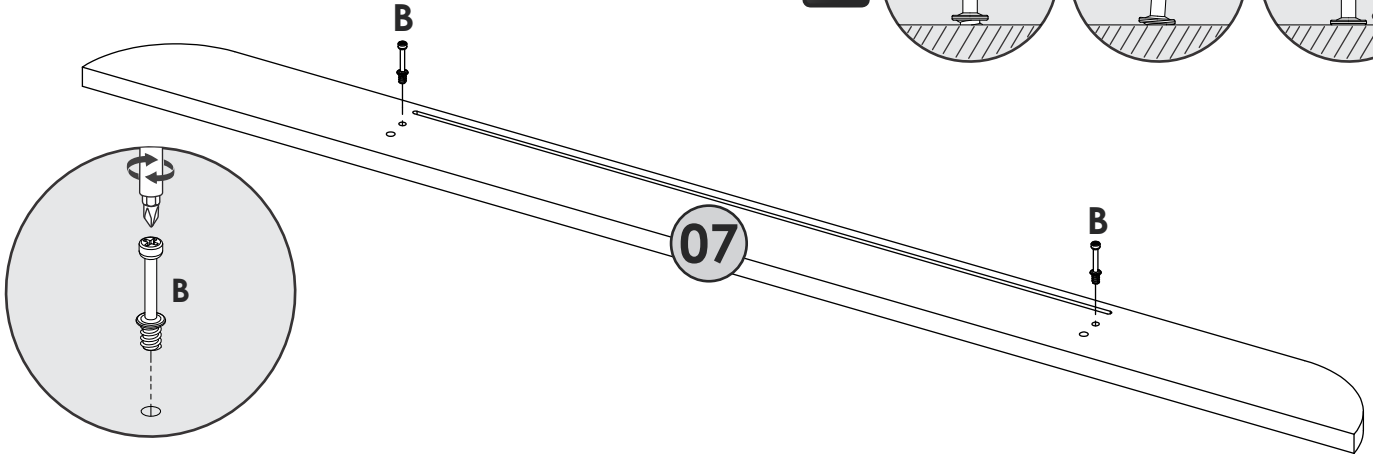
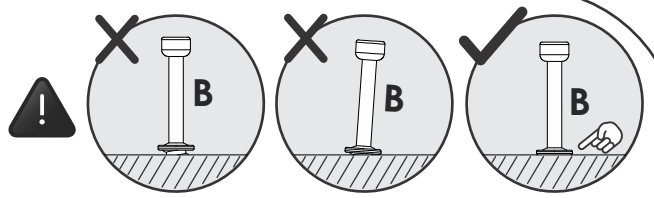

# 05

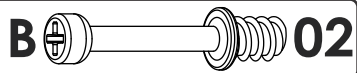
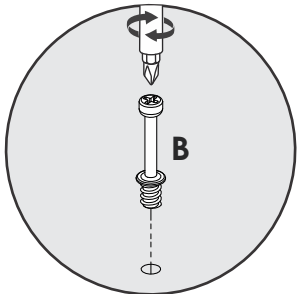
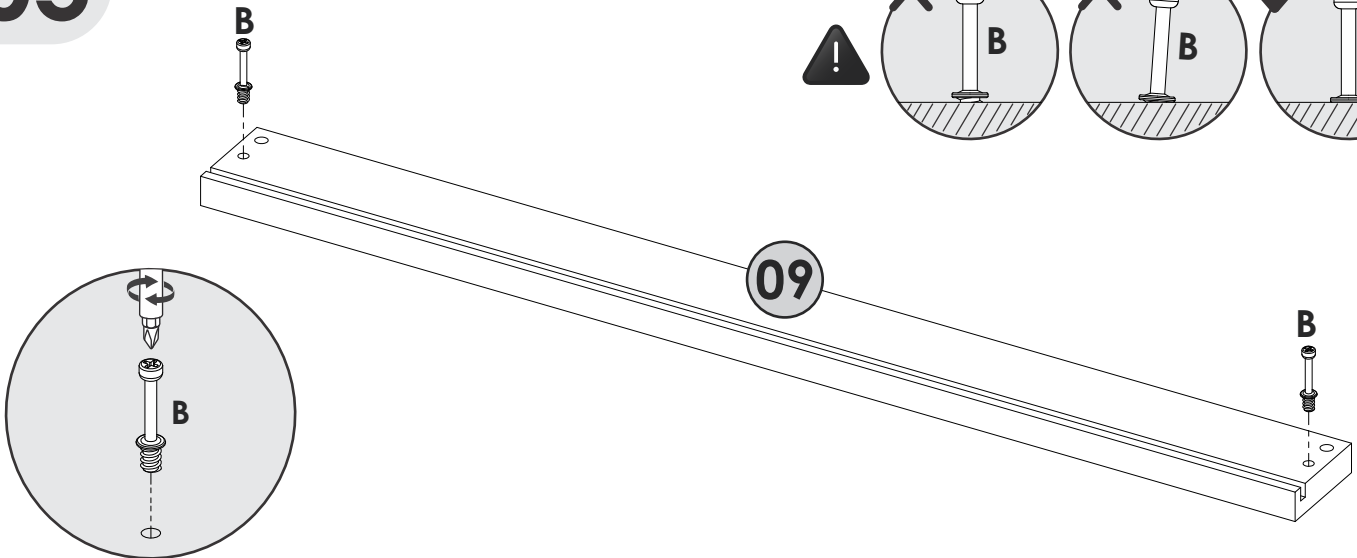
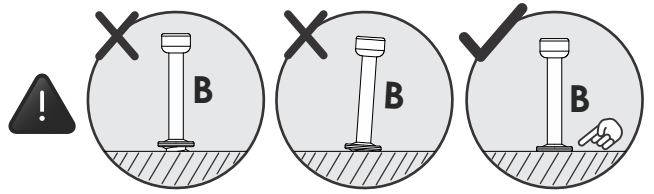

# 06

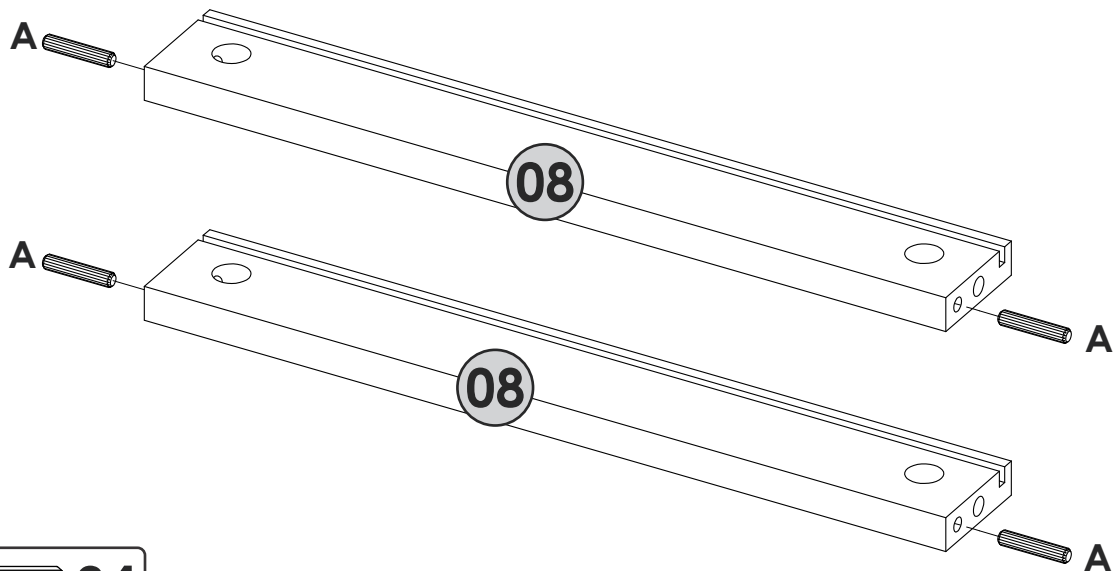

# 07

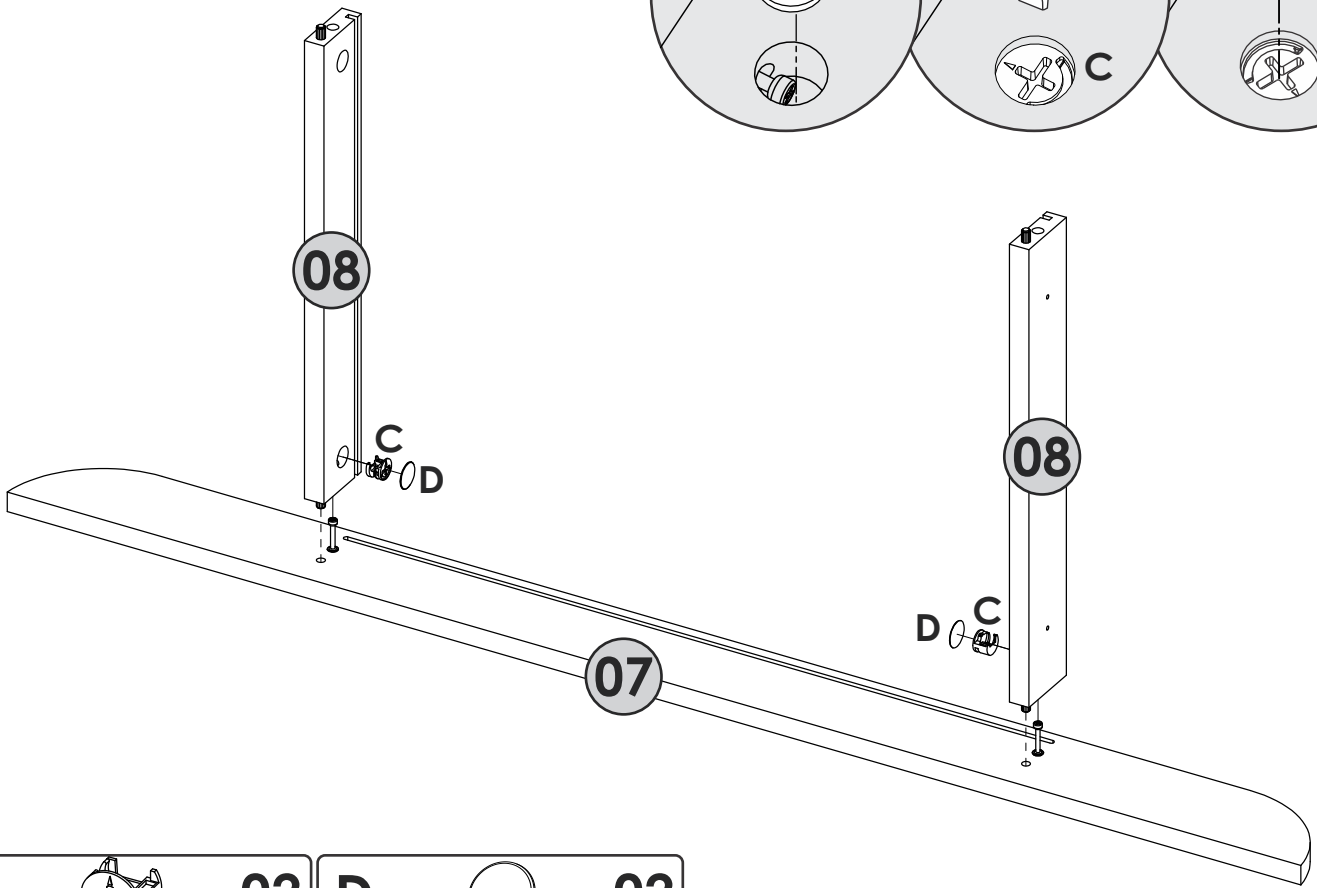
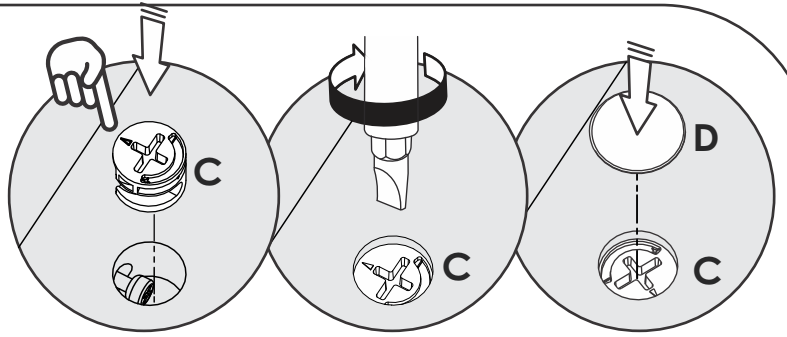

C  02    D  02

# 08

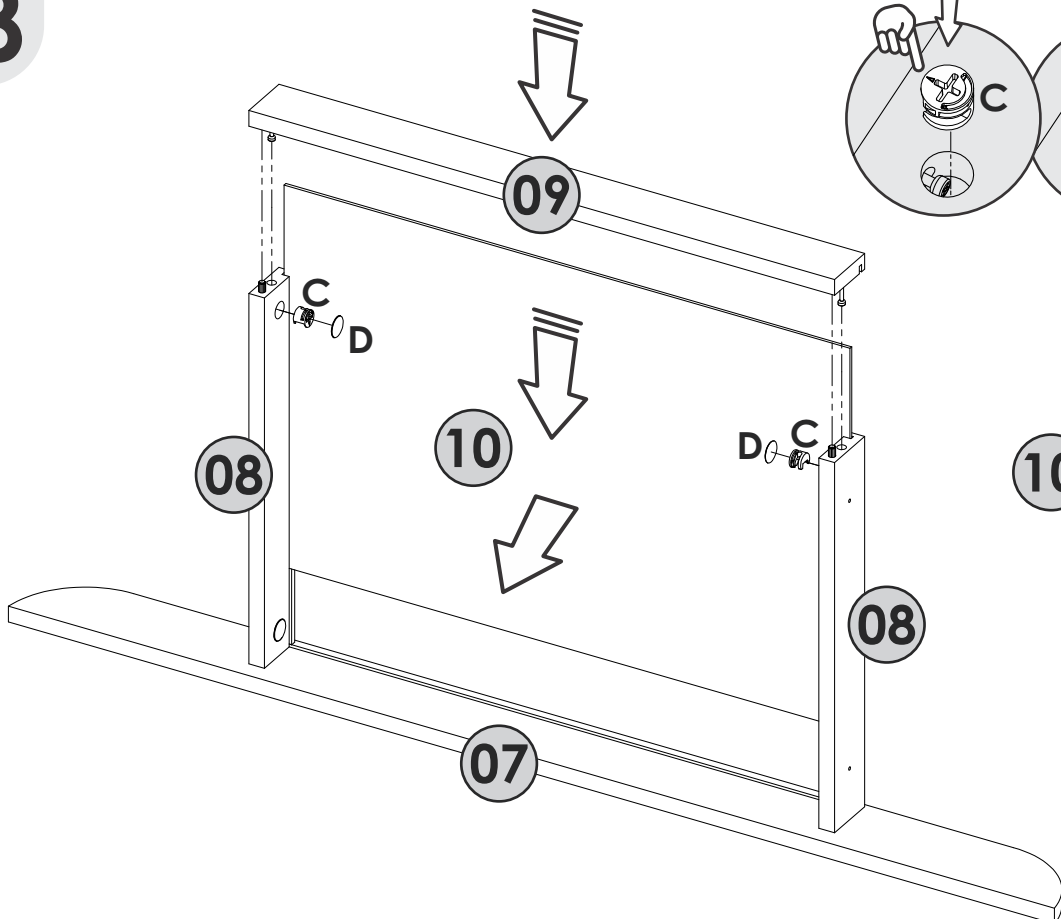
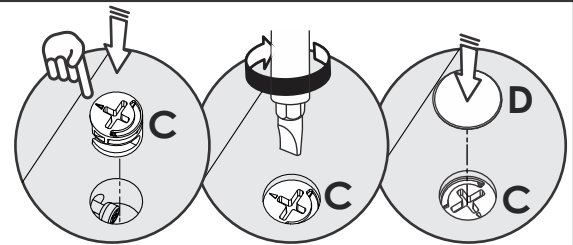

**Lado do acabamento virado para dentro**  
**Lado recubierto para dentro**  
**Revested side turned inside**

C  02    D  02

# 09

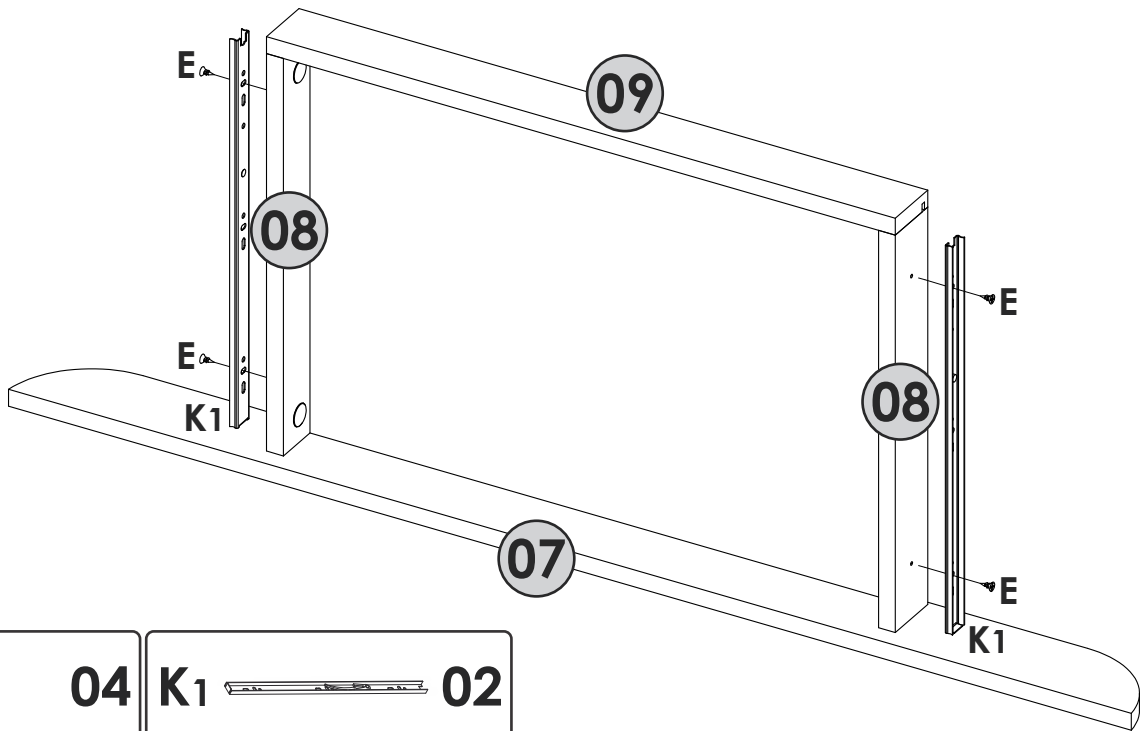
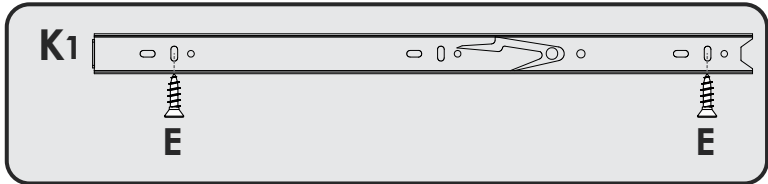

# 10

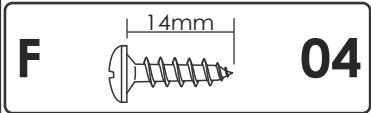
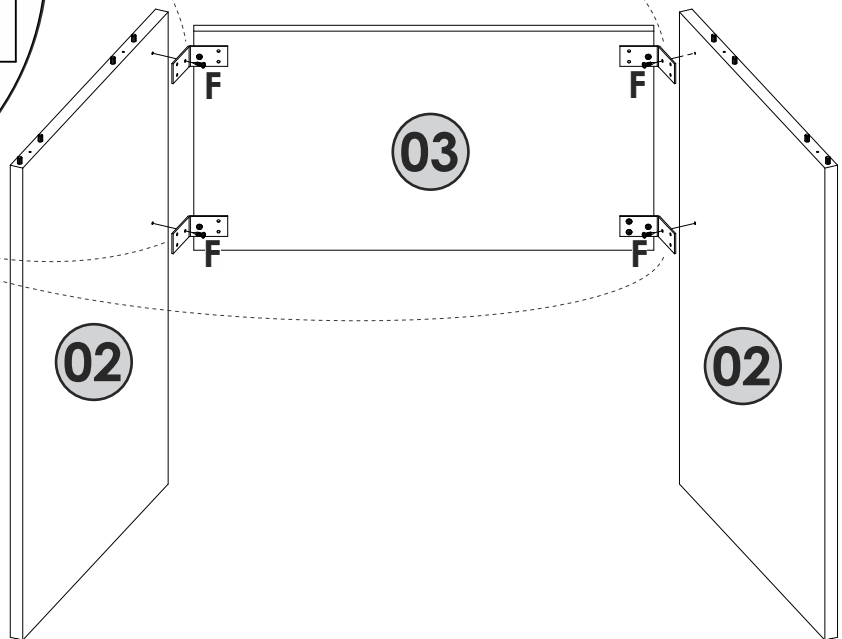
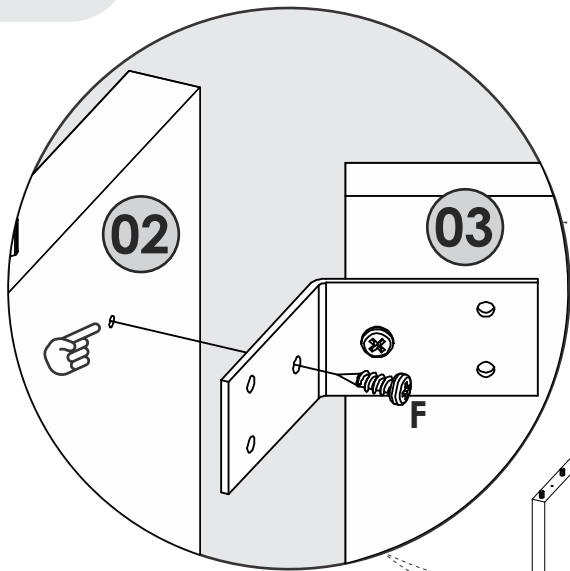
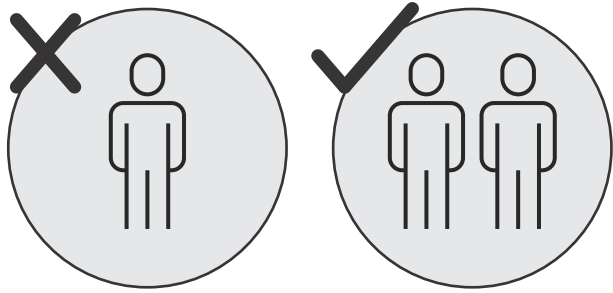

# 11

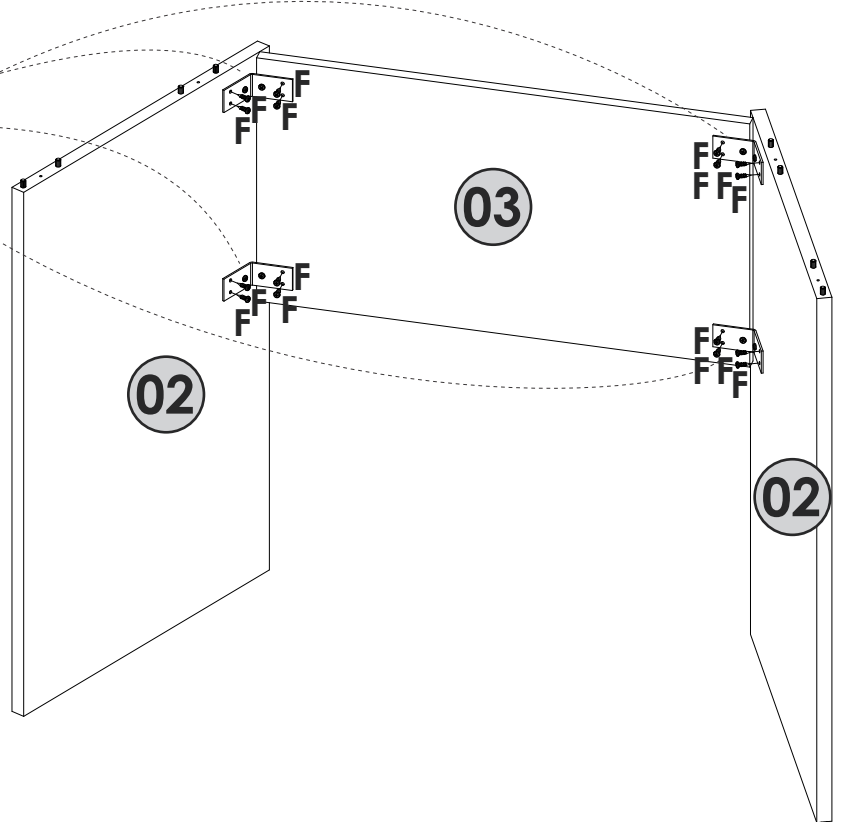
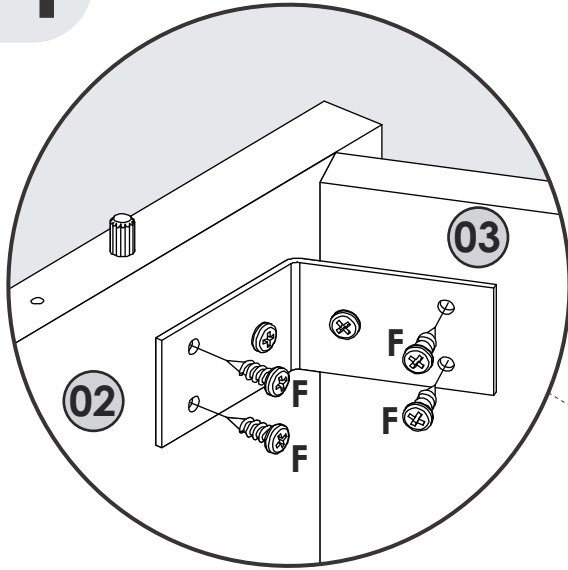

F

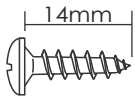

16

# 12

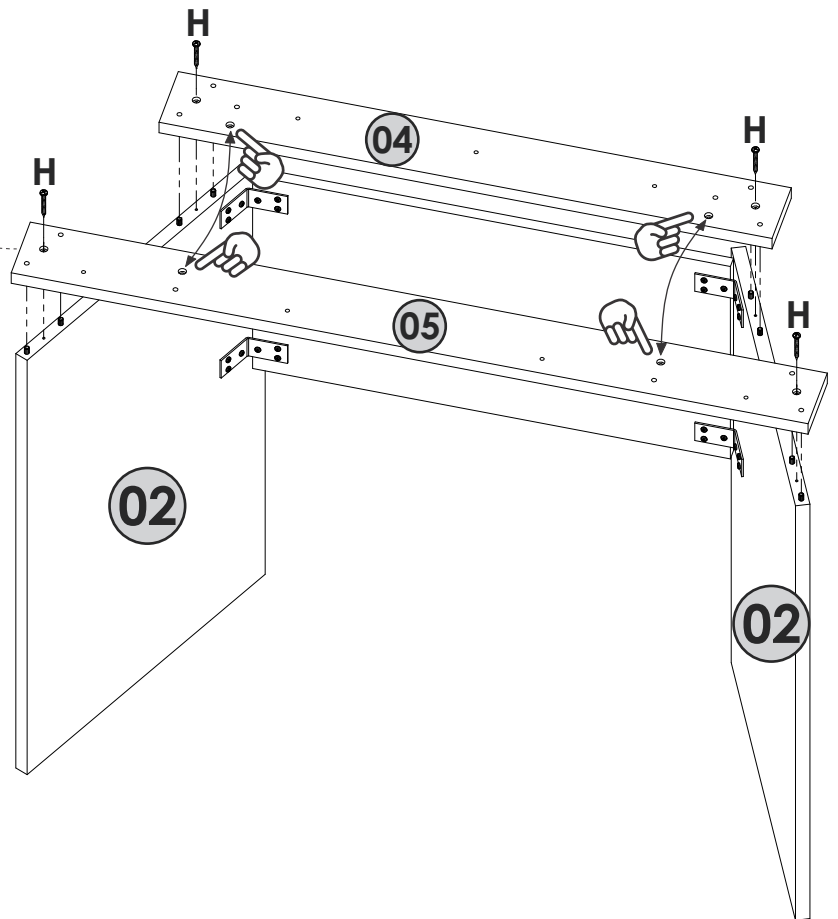
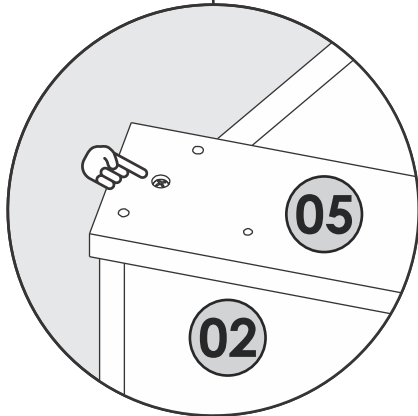
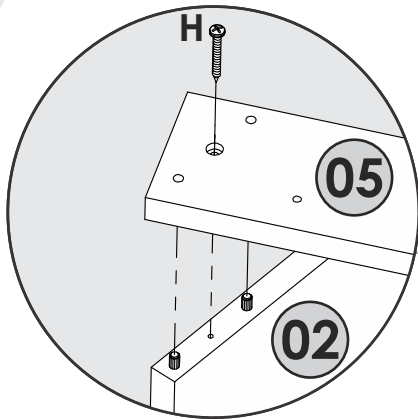

H

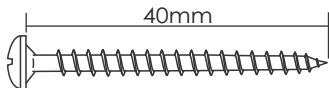

04

# 13

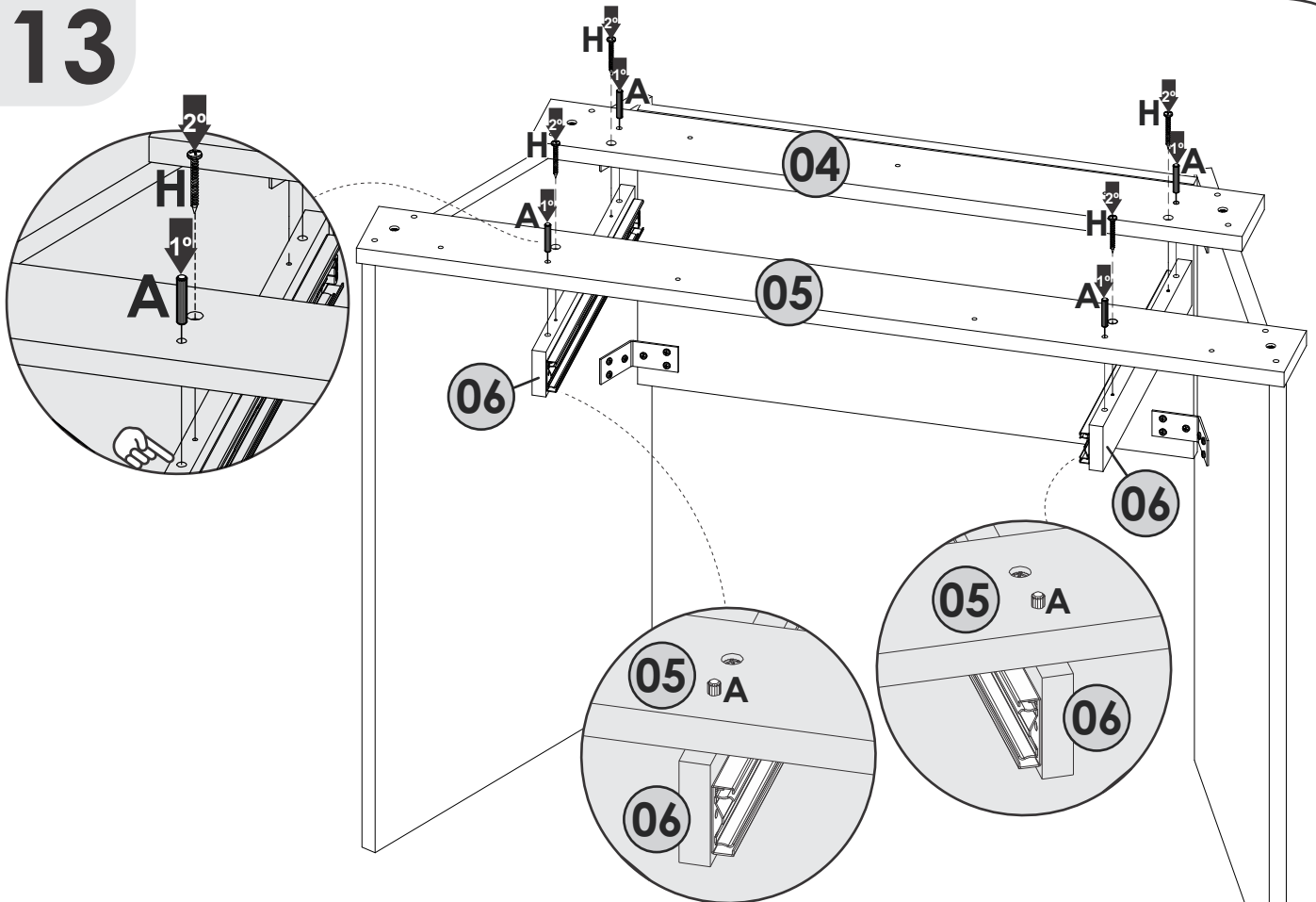

04

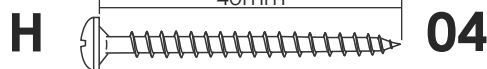

04

# 14

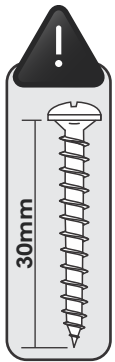

30mm

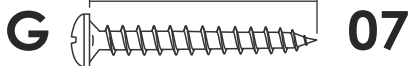
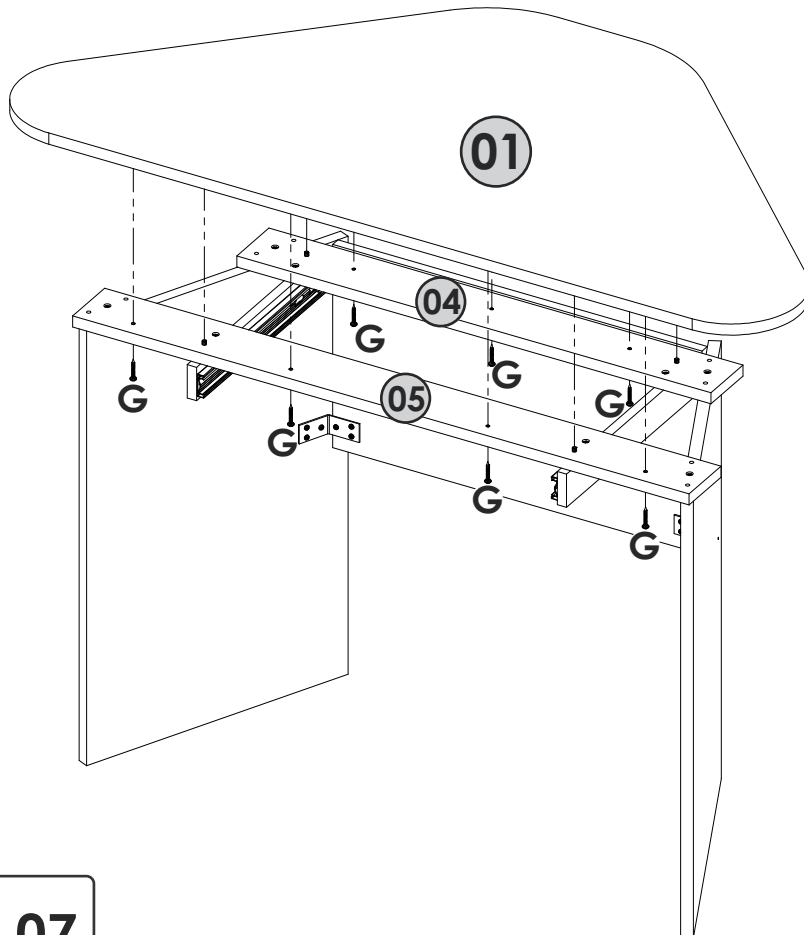

07

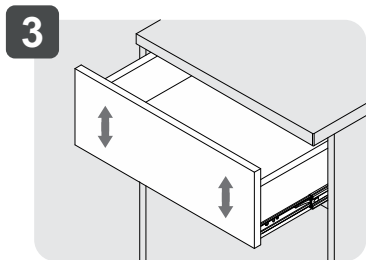
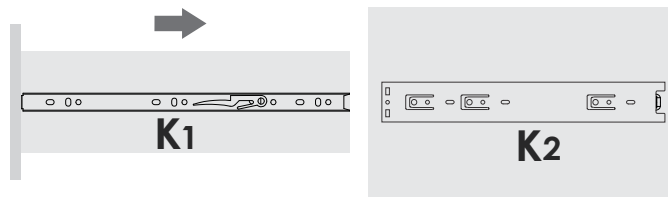
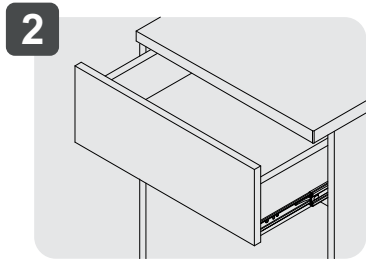
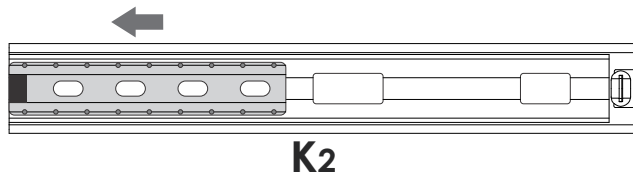
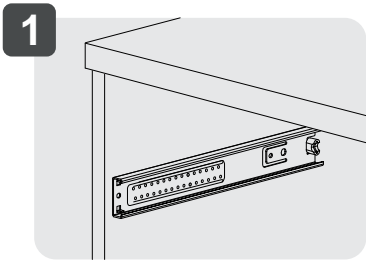
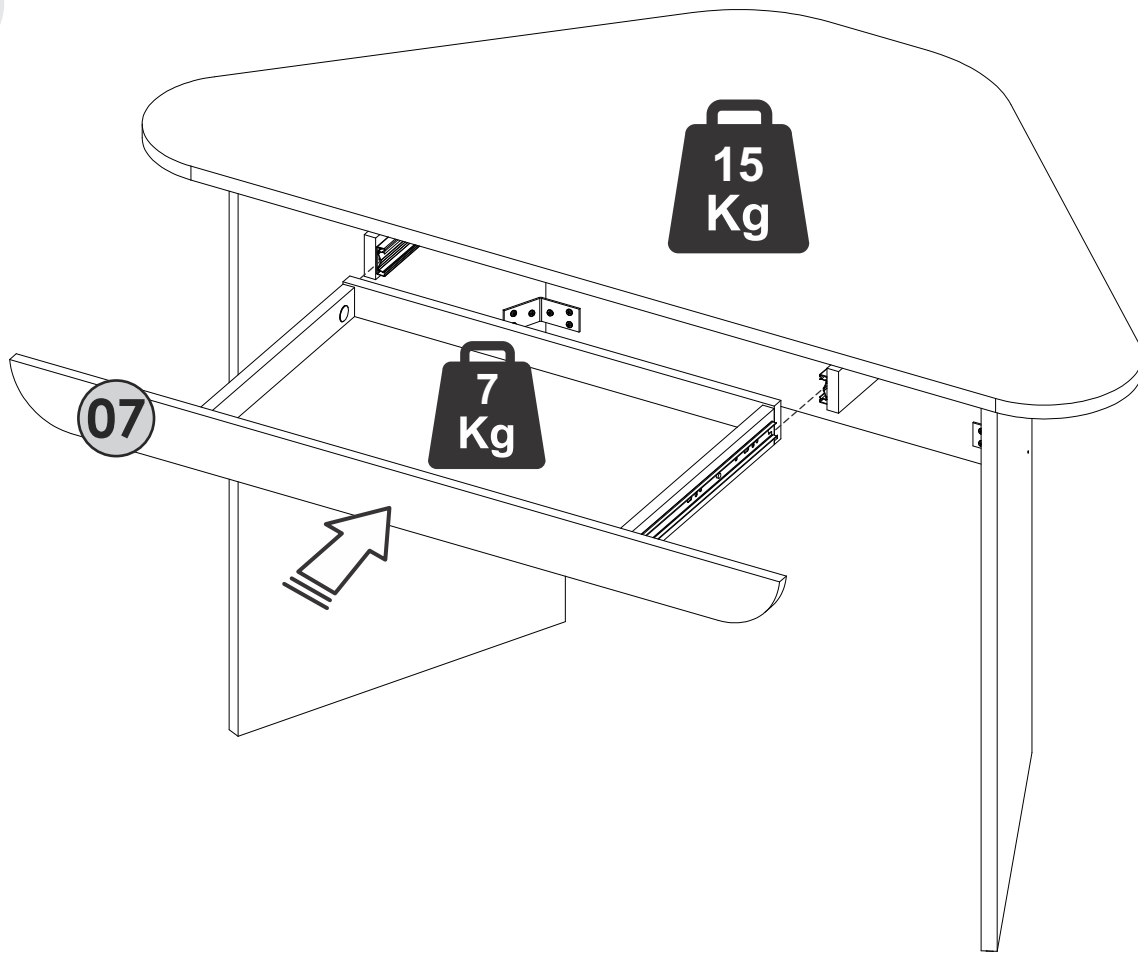

**.1**

**Ajustar a gaveta e colocar os parafusos**  
 Ajustar el cajón y poner los tornillos  
 Adjust the drawer and put the screws

**K1**

**.2**

**K1**      **E**      **E**

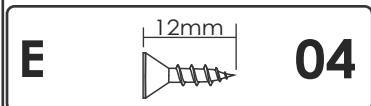

# Obrigado

POR SUA CONFIANÇA EM NOSSO TRABALHO!



Esperamos que sua experiência de compra, montagem e instalação tenha sido perfeita!

Desejamos que seu móvel possa tornar seu Home Office, casa ou escritório, um ambiente muito mais agradável e organizado, fazendo seu trabalho, estudo ou descanso ser muito mais proveitoso!

## APROVEITE SEU MÓVEL ARTANY!

Se tiver alguma dúvida, sugestão ou comentário, pode entrar em contato no nosso WhatsApp (41) 99242-8497, telefone (41)3556-1550, ou email [artany@artany.com.br](mailto:artany@artany.com.br)



Gostou? Compartilhe este momento e marque a gente!



@artanymoveis



# ARTANY®

Arte em Home Office