

# MANUAL DE MONTAGEM / ASSEMBLY INSTRUCTIONS \ PLANO DE ARMADO

**Antes de montar o móvel, leia com atenção o manual de montagem!**

**Before assembling the furniture, carefully read the assembly instructions**

**Antes de armar el mueble, lea con atención el manual de ensamble!**

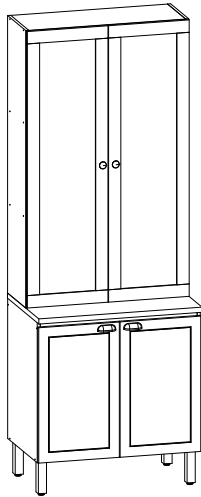

**genialflex**

**Ref.: 1358**

Parabéns! Você comprou um produto de excelente qualidade, fabricado com chapa de madeira de MDP ou MDF, extraída de florestas renováveis. Possui alta resistência e design atual.

Congratulations! You have purchased a product of excellent quality, made from MDP or MDF wood veneer, extracted from renewable forests. It has high strength and current design.

Felicitaciones! Usted compró a un producto de excelente calidad, fabricado con placa de madera de MDP o MDF, proveniente de florestas renovables. Tiene alta resistencia y diseño actual.



**ATENÇÃO  
ATTENTION  
ATENCIÓN**

**1)** Verifique todas as peças antes de começar a montagem.

Check all parts before starting assembly.

Verifique todas las partes antes de empezar el armado.

**2)** Ao começar a montagem, não apoie as peças na parede.

When starting the assembly, do not support the parts on the wall.

Al empezar el armado, no apoyes las partes en la pared.

**3)** Ao colocar as peças e ferragens de lado, cuidado para não perde-las.

When placing parts and hardware aside, be careful not to lose them.

Al poner las piezas y herrajes a parte, cuidado para no dañarlas.

**4)** O móvel deve ser montado no chão, para isso, use a própria caixa para proteger e não danificar o piso.

The furniture must be mounted on the floor, to do this, use the box it self to protect and not damage the floor.

El mueble suele ser armado al piso, para eso, use la propia caja para protegerlo y no dañar al piso.

**5)** Comece a montagem seguindo as instruções passo a passo.

Begin assembly by following the step-by-step.

Comience el armado siguiendo las instrucciones paso a paso.

**6)** É de responsabilidade do montador seguir as instruções desse manual, que são fundamentais para a estrutura do móvel.

It's the assembler's responsibility to follow the instructions in this manual, which are fundamental to the structure of the furniture.

Es de responsabilidad del armador seguir las instrucciones de este manual, que son fundamentales para la estructura del mueble.

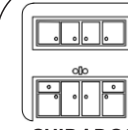

**CUIDADOS  
CARE  
CUIDADO**

**1)** A conservação e limpeza deve ser feita com um pano levemente umedecido com água.

Care and cleaning should be done with a cloth slightly moistened with water.

La conservación y limpieza debe ser hecha con un trapo levemente humedecido en agua.

**2)** Não use produtos abrasivos, como saponáceo, detergentes e esponja de aço.

Do not use abrasive products, such as soap, detergents and steel sponge.

No use productos abrasivos, como saponáceo, detergentes y esponja de acero.

**3)** Não use cera ou óleo para dar brilho ao móvel.

Do not use wax or oil to shine the furniture.

No use cera o aceites para darle brillo al mueble.

**4)** Não exponha o móvel a intempéries e nem ao calor excessivo.

Do not expose the furniture to weather or excessive heat.

No exponer el mueble a intemperies ni al calor excesivo.

**5)** Ao terminar a montagem, limpe o ambiente e o móvel.

When the assembly is finished, clean the room and the furniture.

Al terminar el armado, limpie al ambiente y al mueble.

## FERRAMENTAS / TOOLS / HERRAMIENTAS



MARTELO  
HAMMER  
MARTILLO



MARTELO DE BORRACHA  
RUBBER HAMMER  
MARTILLO GOMA



NÃO RECOMENDÁVEL  
NOT ADVISABLE  
NO RECOMENDABLE



CHAVE PHILLIPS  
PHILLIPS SCREWDRIVER  
LLAVE PHILLIPS







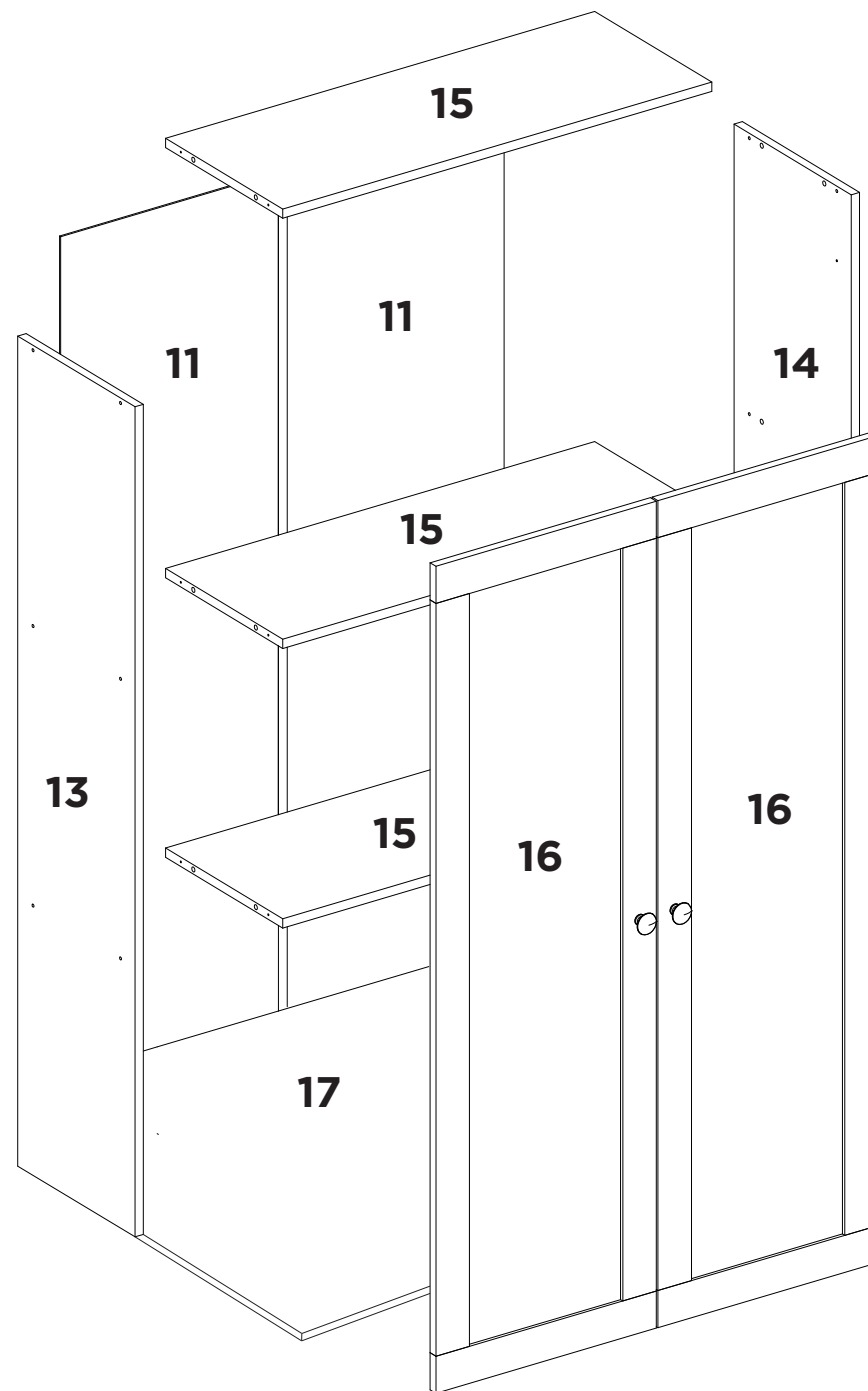

TRENA  
MEASURING TAPE  
CINTA MÉTRICA

## PEÇAS / PARTS / PIEZAS

Nº No Num	DESCRIÇÃO DESCRIPTION DESCRIPCIÓN	QTD QTY CANT
11	TAMPO TOP ARRIBA	02
13	LATERAL ESQUERDA LEFT SIDE PANEL LATERAL IZQUIERDA	01
14	LATERAL DIREITA RIGHT SIDE PANEL LATERAL DERECHAA	01
15	PRATELEIRA PLATE PANEL REPISA	03
16	PORTA - PRATELEIRA DOOR - SHELF ESTANTE - PUERTA	02
17	COSTA BACK PANEL TRASERO	

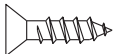
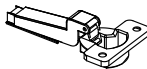

## FERRAGENS / HARDWARE / HERRAJES

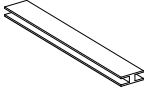
Nº No Num	DESCRIÇÃO DESCRIPTION DESCRIPCIÓN	QTD QTY CANT
A	 CAVILHA 6X30MM WOODEN DOWEL 6X30MM TARUGO 6X30MM	16
B	 PARAFUSO 3,5X40MM SCREW 3,5X40MM TORNILLO 3,5X40MM	16
C	 PREGO ANELADO RINGED NAIL CLAVO ANILLADO	29
D	 PARAFUSO 3,5X25MM SCREW 3,5X25MM TORNILLO 3,5X25MM	34
E	 DOBRADIÇA HINGE BIZAGRA	06
F	 CALÇO PARA DOBRADIÇA HINGE SHED CALZO DE BISAGRA	06
G	 OU  PUXADOR HANDLE TIRADOR	02
H	 CANTONEIRA DE 2 FUROS METALLIC ANGLE CANTONERA 2 AGUJEROS	04
I	 PERFIL PROFILE PERFIL	01

UTILIZE A RÉGUA PARA IDENTIFICAR OS PARAFUSOS.  
USE THE RULER TO IDENTIFY THE SCREWS  
UTILICE LA REGLA PARA IDENTIFICAR LOS TORNILLOS

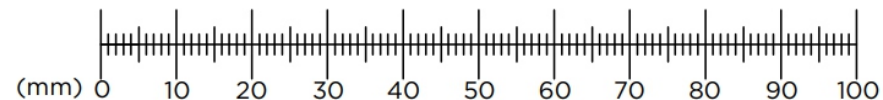

**PESO SUPORTADO / WEIGHT SUPPORTED / PESO SOPORTADO**

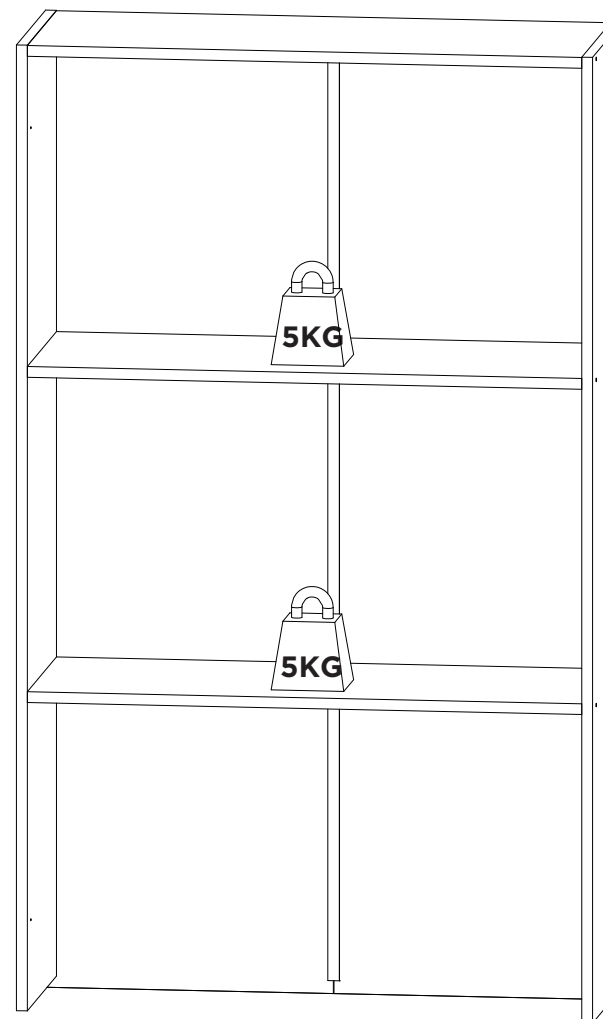

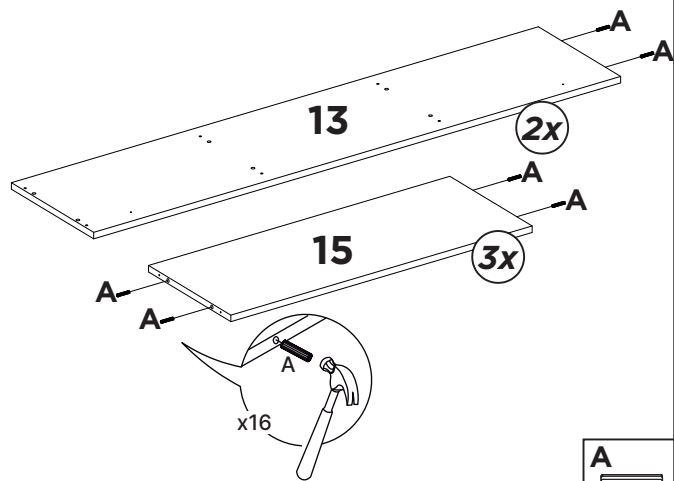
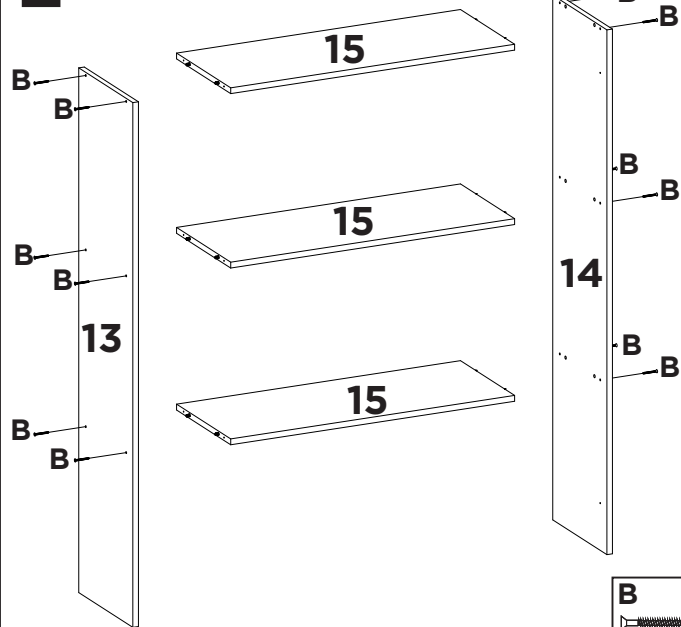
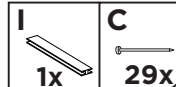
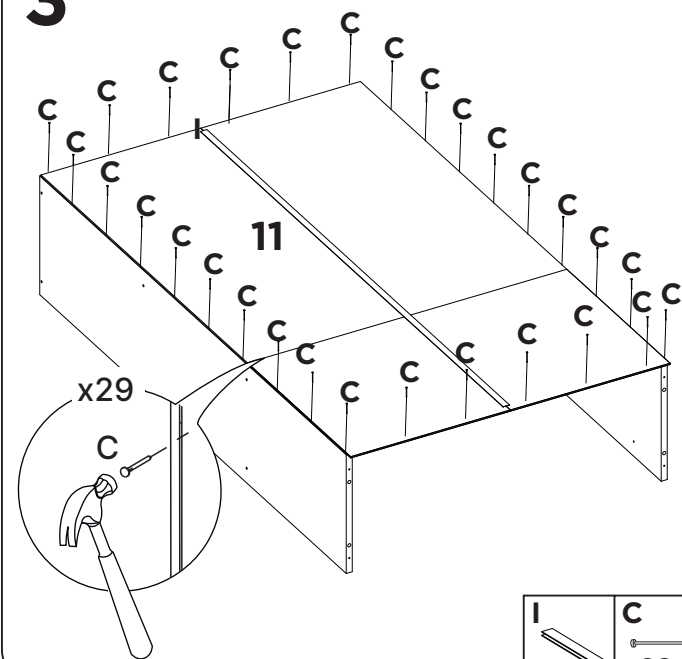
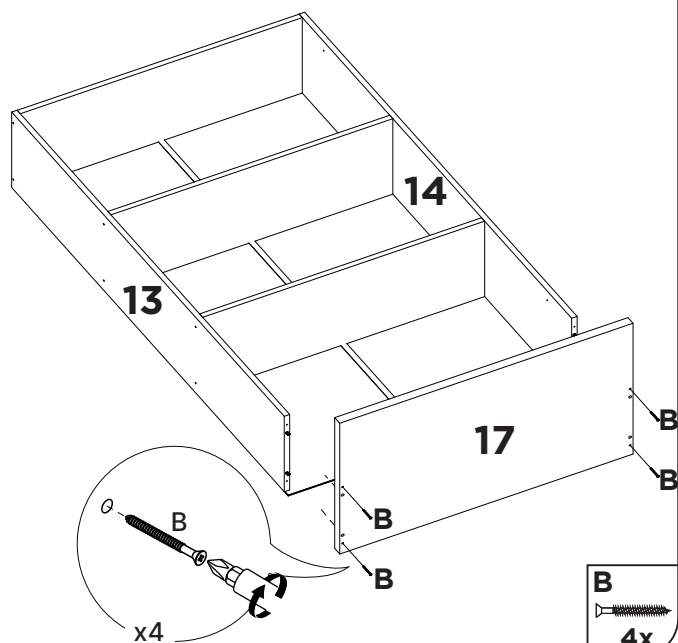
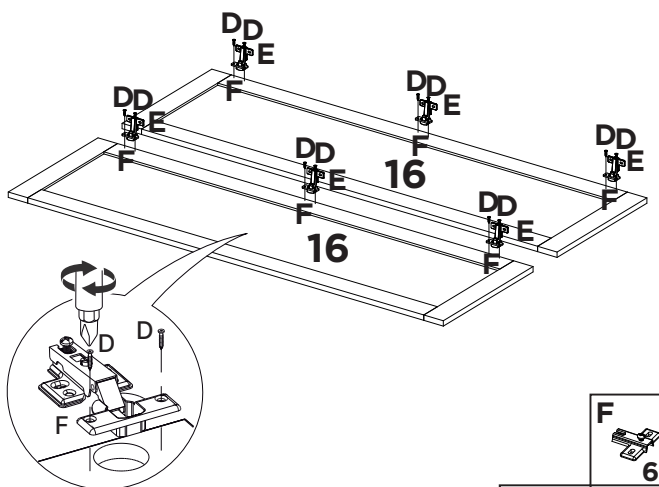
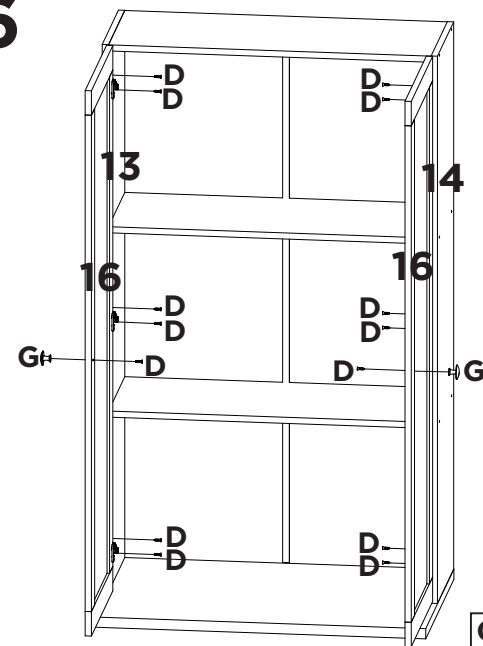
**1****2****3****4****5****6**

7

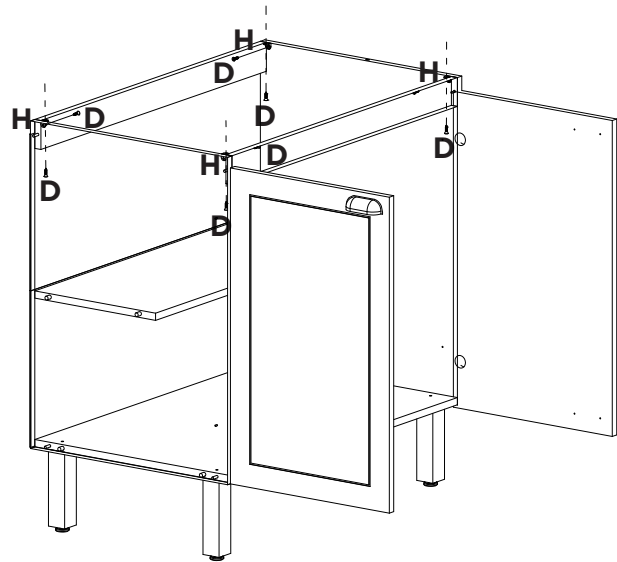
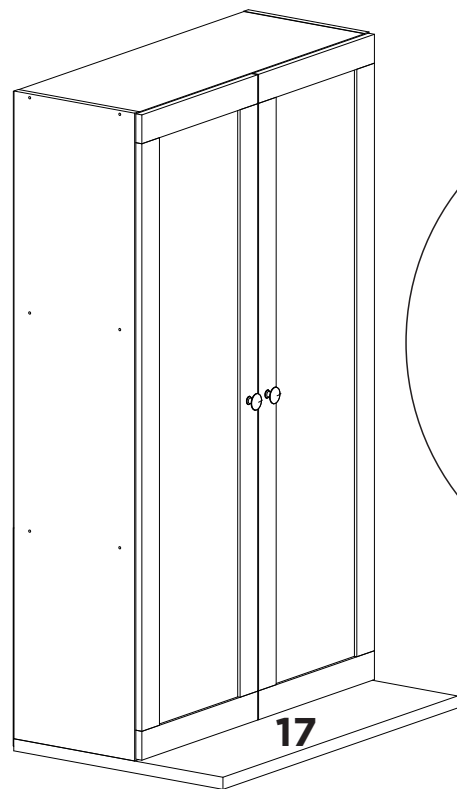

8

