

ASSEMBLY INSTRUCTIONS MANUAL DE MONTAGEM / INSTRUCCIONES DE ARMADO

Reference
Referência
Referencia

Revise
Revisão
Revisión **00**

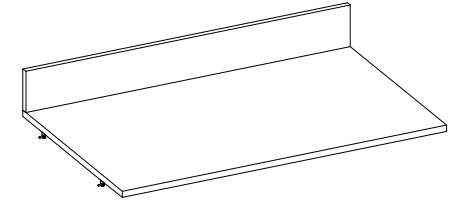

YOU WILL NEED VOCÊ VAI PRECISAR DE / USTED NECESITARÁ

Tools not supplied
Ferramentas não fornecidas / Herramientas no incluidas

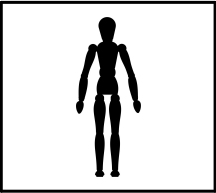

1 Person
1 Pessoa
1 Persona

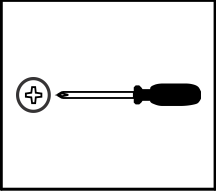

Screwdriver Phillips
Chave Phillips
Destornillador cruz

PARTS IDENTIFICATION IDENTIFICAÇÃO DAS PEÇAS / IDENTIFICACIÓN DE LAS PIEZAS

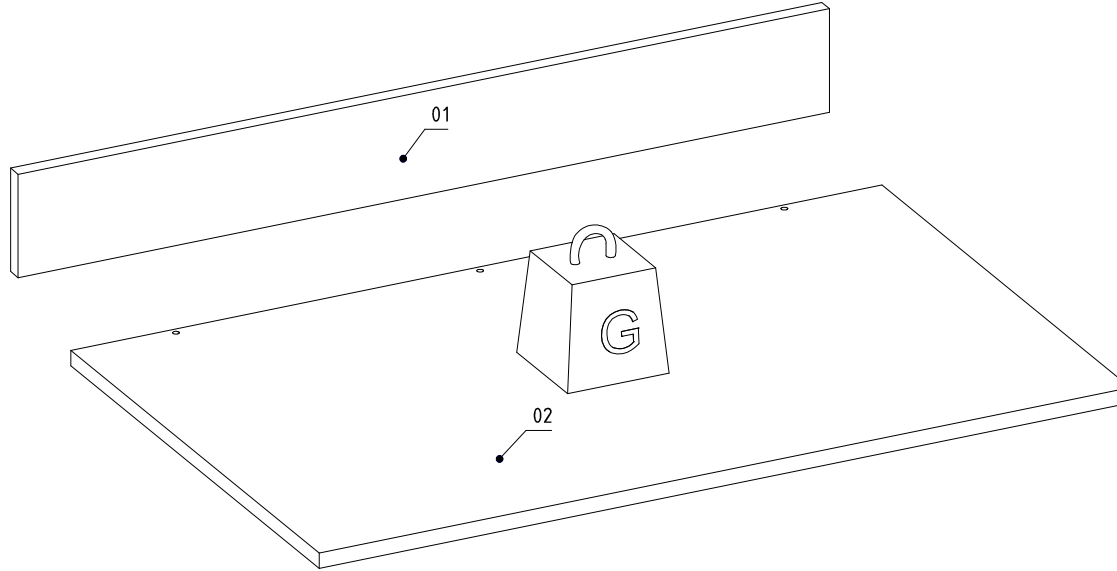

Nº	Measures_Inches	Medidas_cm	Qty./Qtd.
01	31 1/2 x 3 7/8 x 5/8	80.0 x 10.0 x 1.5	1
02	31 1/2 x 19 1/4 x 5/8	80.0 x 49.0 x 1.5	1



MAXIMUM RECOMMENDED WEIGHT
BEING THIS EVENLY DISTRIBUTED.

PESO MÁXIMO RECOMENDADO SENDO
ESTE DISTRIBUÍDO UNIFORMEMENTE.

PESO MÁXIMO RECOMENDADO SIENDO
ESTE UNIFORMEMENTE DISTRIBUIDO.

	LB	KG
G	33	15

IDENTIFICATION OF ACCESSORIES IDENTIFICAÇÃO DOS ACESSÓRIOS/ IDENTIFICACIÓN DE ACCESORIOS



The separation of the accessories before you start the assembly will facilitate the same. In case of doubt on the size of the screws and bolts, use the ruler to bottom of page.
 A separação dos acessórios antes de iniciar a montagem facilitará a mesma. Em caso de dúvida no tamanho dos parafusos e cavilhas, utilize a régua ao final da página.
 La separación de los accesorios antes de comenzar el armado facilitará el mismo. En caso de duda sobre el tamaño de los tornillos y taquetes, utilice la regla al pie de página.

D		Flat head screw Parafuso chato / Tornillo de cabeza plana	4,0x40 mm	3
S		Pan head screw Parafuso panela / Tornillo de pan	3,5x14 mm	8
Y18		Zamac bracket Cantoneira zamac/ Suporte de zamac	13x13 mm	4

ASSEMBLY MONTAGEM / ARMADO

01

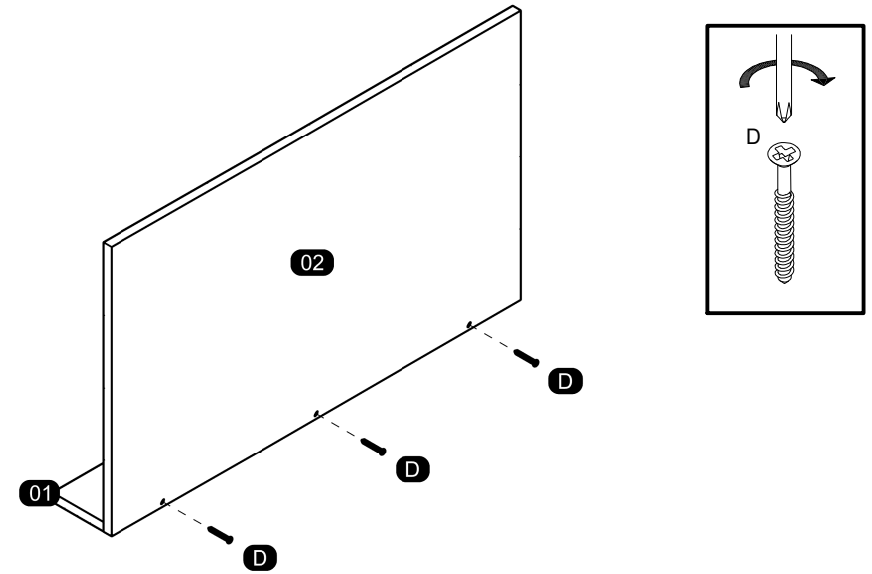

02

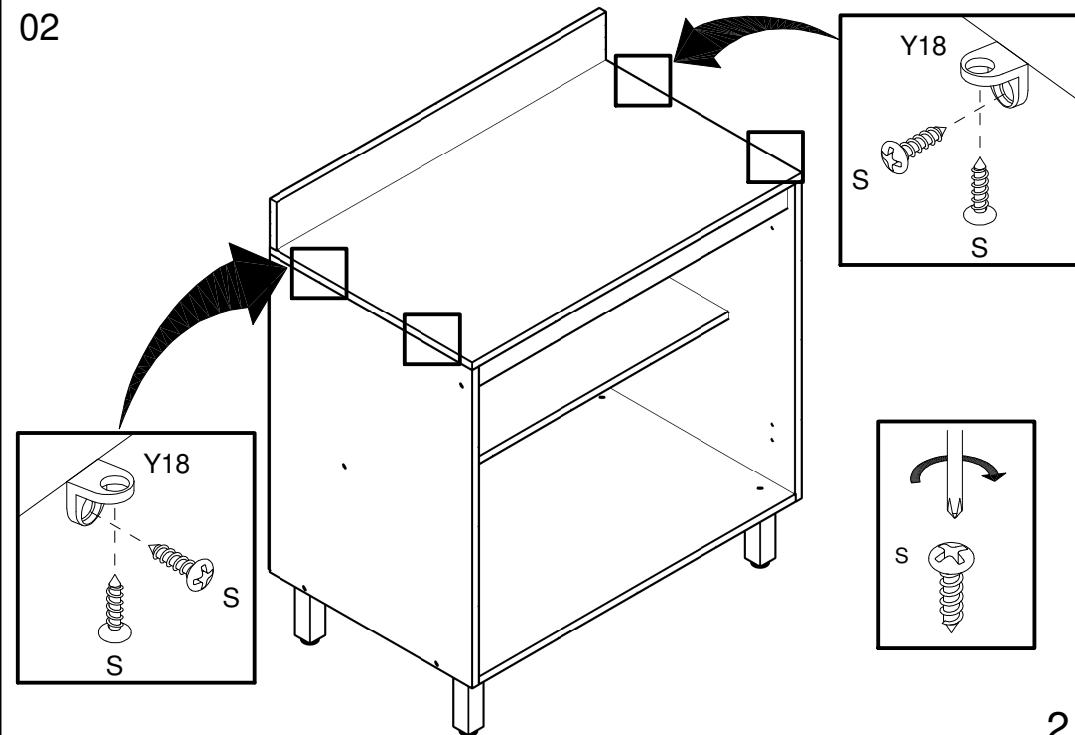

ASSEMBLY INSTRUCTIONS MANUAL DE MONTAGEM / INSTRUCCIONES DE ARMADO

2 DOORS BASE CABINET
BALCAO 2P
BALCÓN 2 PUERTAS

Reference
Referência
Referencia **240601** | Revise
| Revisão
| Revisión **00**

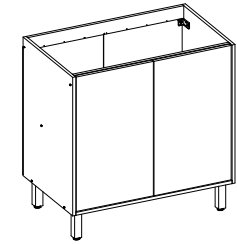

**YOU WILL NEED
VOCÊ VAI PRECISAR DE / USTED NECESITARÁ**

Tools not supplied
Ferramentas não fornecidas / Herramientas no incluidas

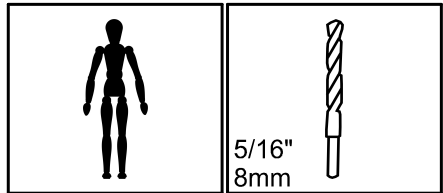

1 Person
1 Pessoa
1 Persona

Drill bit
Broca
Taladro

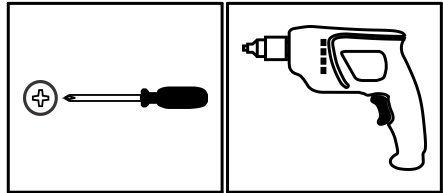

Screwdriver Phillips
Chave Phillips
Destornillador cruz

Drill machine
Furadeira
Taladro

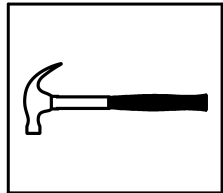

Hammer
Martelo
Martillo

 MAXIMUM RECOMMENDED WEIGHT
BEING THIS EVENLY DISTRIBUTED.
PESO MÁXIMO RECOMENDADO SENDO
ESTE DISTRIBUÍDO UNIFORMEMENTE.
PESO MÁXIMO RECOMENDADO SIENDO
ESTE UNIFORMEMENTE DISTRIBUIDO.

—	LB	KG
F	22	10

**PARTS IDENTIFICATION
IDENTIFICAÇÃO DAS PEÇAS / IDENTIFICACIÓN DE LAS PIEZAS**

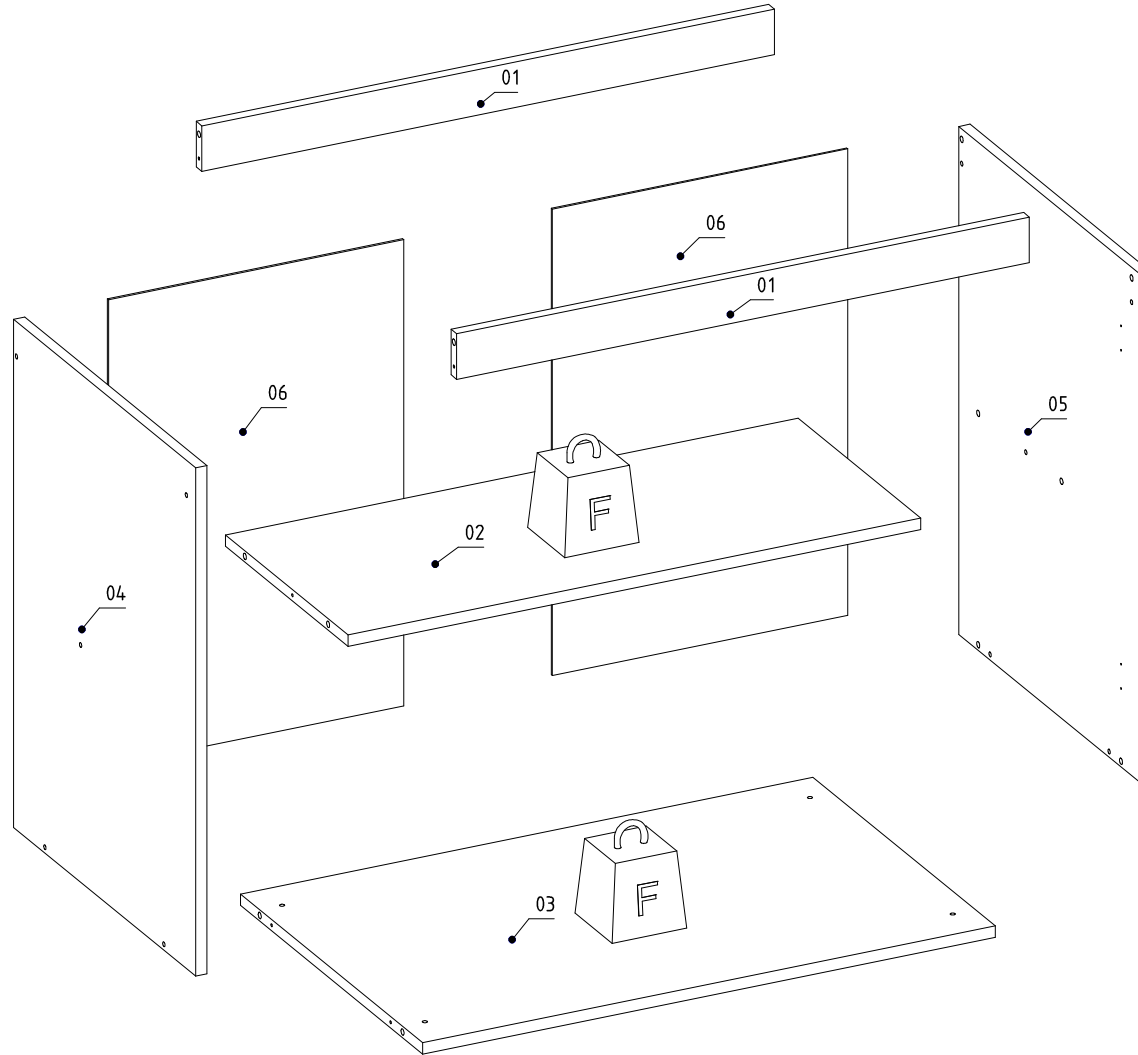

Nº	Measures_Inches	Medidas_cm	Qty./Qtd.
01	30 3/8 x 2 3/8 x 5/8	77.0 x 6.0 x 1.5	2
02	30 3/8 x 13 x 5/8	77.0 x 33.0 x 1.5	1
03	30 3/8 x 19 1/4 x 5/8	77.0 x 49.0 x 1.5	1
04	26 3/8 x 19 1/4 x 5/8	67.0 x 49.0 x 1.5	1
05	26 3/8 x 19 1/4 x 5/8	67.0 x 49.0 x 1.5	1
06	24 1/4 x 15 5/8 x 1/8	61.5 x 39.7 x 0.3	2

IDENTIFICATION OF ACCESSORIES IDENTIFICAÇÃO DOS ACESSÓRIOS/ IDENTIFICACIÓN DE ACCESORIOS



The separation of the accessories before you start the assembly will facilitate the same. In case of doubt on the size of the screws and bolts, use the ruler to bottom of page.
 A separação dos acessórios antes de iniciar a montagem facilitará a mesma. Em caso de dúvida no tamanho dos parafusos e cavilhas, utilize a régua ao final da página.
 La separación de los accesorios antes de comenzar el armado facilitará el mismo. En caso de duda sobre el tamaño de los tornillos y taquetes, utilice la regla al pie de página.

A		Flanged head screw Parafuso flangeado / Tornillo de cabeza flangeada	5,0x60 mm	2
A23		Foot Pé Quadrado FP / Pie	140 mm	4
B3		Bushing Bucha expansiva / Tapón	8x50 mm	2
C		Flanged head screw Parafuso flangeado / Tornillo de cabeza flangeada	4,5x45 mm	4
C1		Metal claw Garra de metal / Garra metal	-	1
D5		Hinge shim Calço dobradiça / Bisagra de calce	-	4
D6		Metal hinge super hight Dobradiça super alta / Bisagra alta	26mm	4
E		Wooden dowel Cavilha / Taquete	8x30 mm	12
N		Nail Prego / Clavo	10x10	31
N5		Support "L" Suporte "L" / Soporte "L"	-	2
O		Flat head screw Parafuso chato / Tornillo de cabeza plana	4,5x45 mm	10
S		Pan head screw Parafuso panela / Tornillo de pan	3,5x14 mm	20



PRE-ASSEMBLE PRÉ-MONTAGEM / PRE ARMADO

01

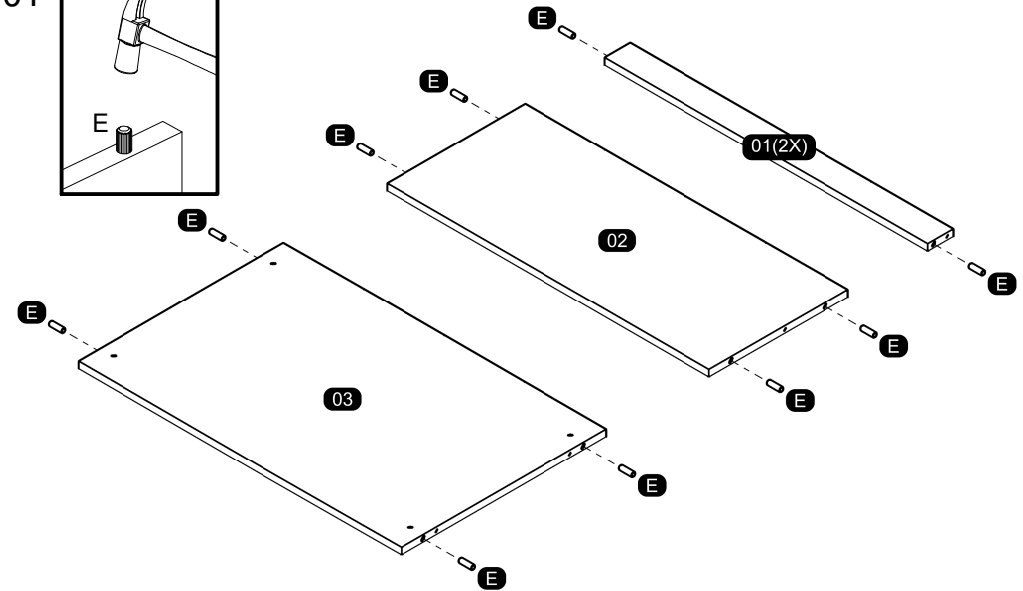
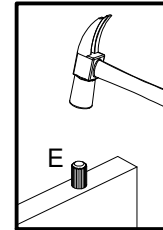

ASSEMBLY MONTAGEM / ARMADO

02

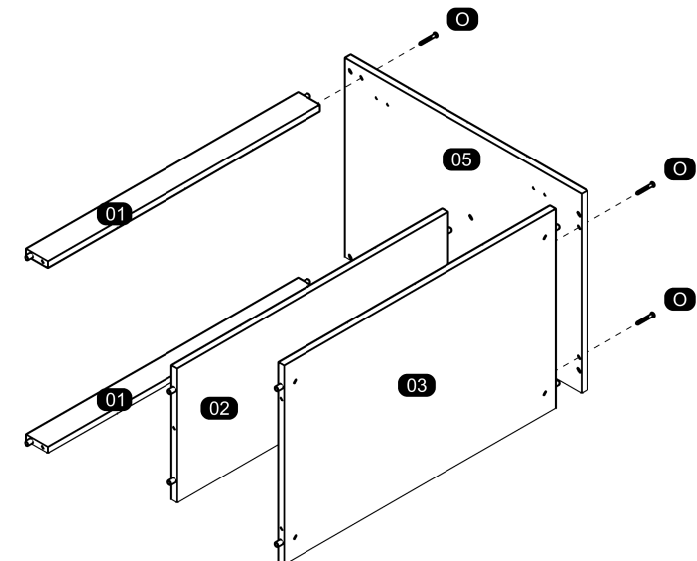
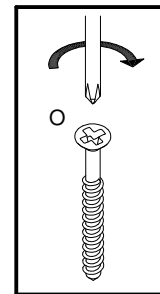

03

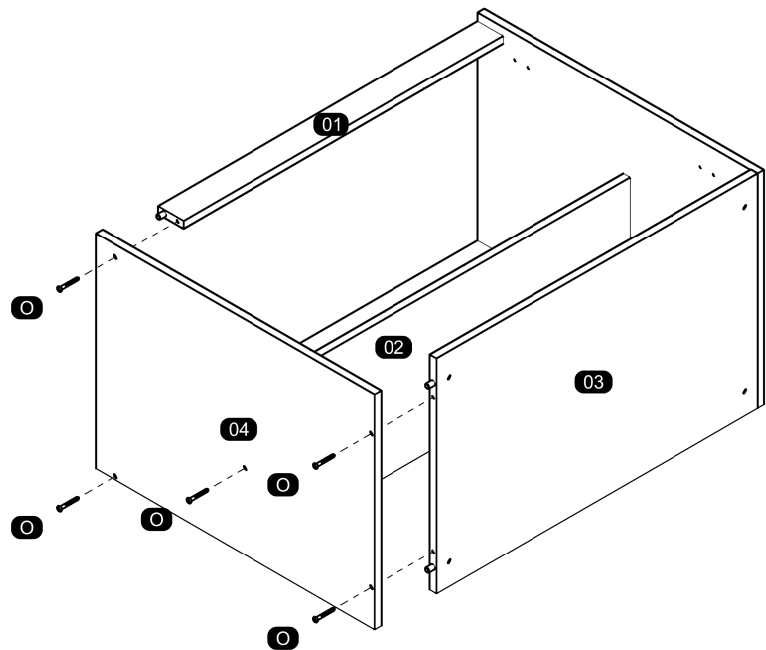

05

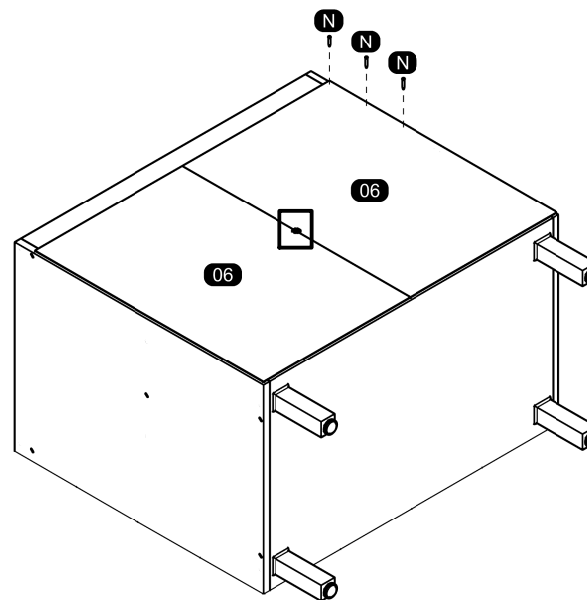
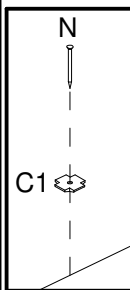

Furniture back
Parte traseira do móvel
Trasero del mueble

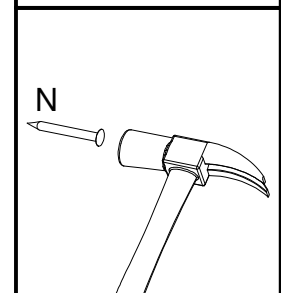
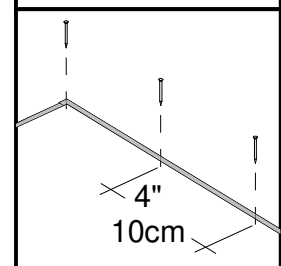

04

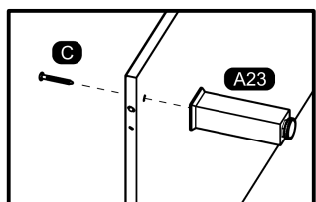
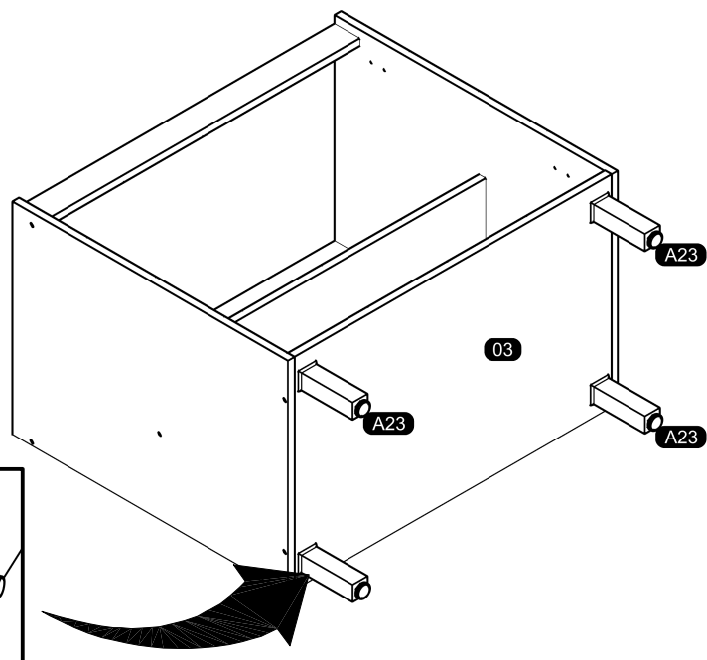

06

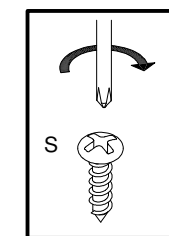
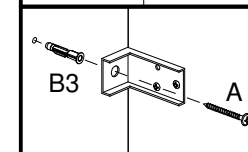
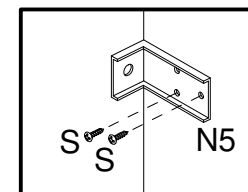
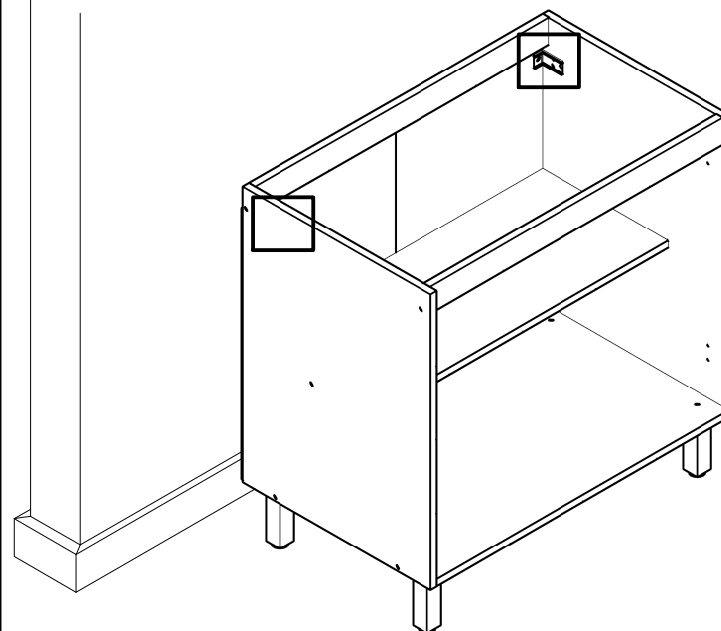

ASSEMBLY INSTRUCTIONS MANUAL DE MONTAGEM / INSTRUCCIONES DE ARMADO

Reference
Referência
Referencia

| Revise
| Revisão
| Revisión

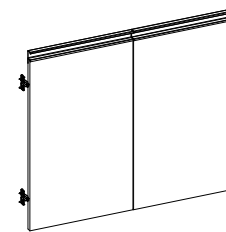

YOU WILL NEED VOCÊ VAI PRECISAR DE / USTED NECESITARÁ

Tools not supplied
Ferramentas não fornecidas / Herramientas no incluidas

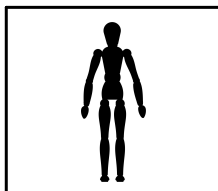

1 Person
1 Pessoa
1 Persona

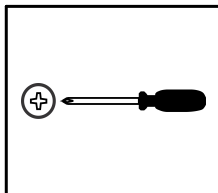

Screwdriver Phillips
Chave Phillips
Destornillador cruz



MAXIMUM RECOMMENDED WEIGHT
BEING THIS EVENLY DISTRIBUTED.

PESO MÁXIMO RECOMENDADO SENDO
ESTE DISTRIBUÍDO UNIFORMEMENTE.

PESO MÁXIMO RECOMENDADO SIENDO
ESTE UNIFORMEMENTE DISTRIBUIDO.

—	LB	KG
---	----	----

PARTS IDENTIFICATION IDENTIFICAÇÃO DAS PEÇAS / IDENTIFICACIÓN DE LAS PIEZAS

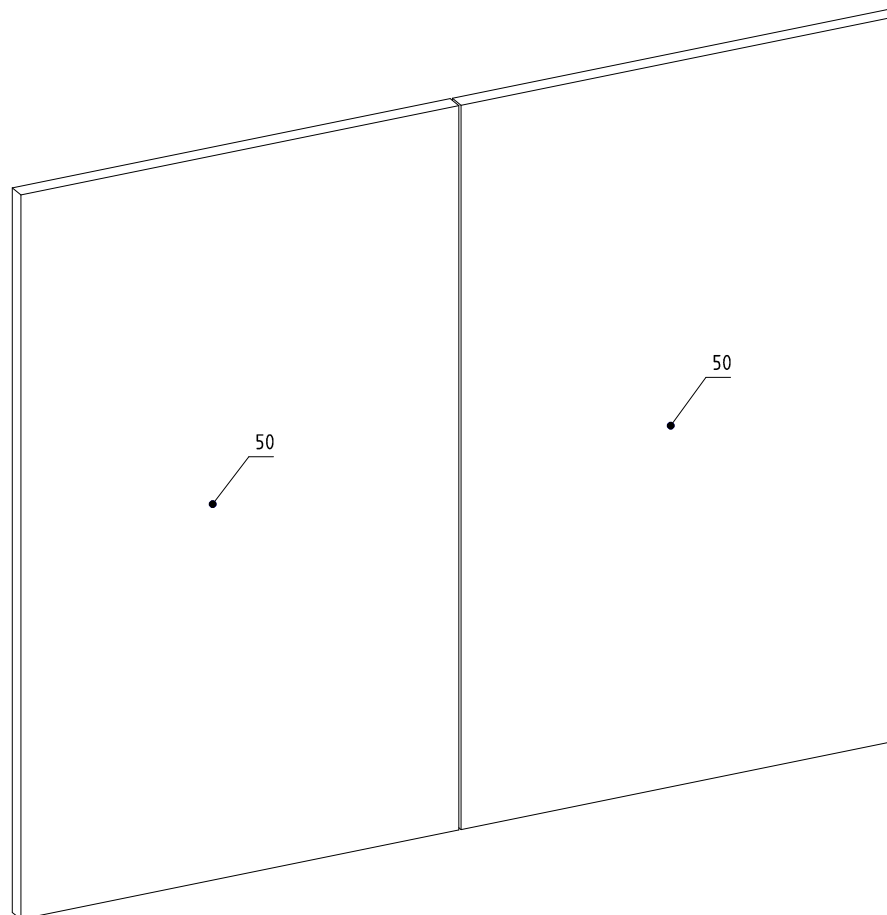

Nº	Measures_Inches	Medidas_cm	Qty./Qtd.
50	24 3/8 x 15 x 5/8	61.8 x 38.1 x 1.5	2

IDENTIFICATION OF ACCESSORIES IDENTIFICAÇÃO DOS ACESSÓRIOS/ IDENTIFICACIÓN DE ACCESORIOS



The separation of the accessories before you start the assembly will facilitate the same. In case of doubt on the size of the screws and bolts, use the ruler at the bottom of the page.
 A separação dos acessórios antes de iniciar a montagem facilitará a mesma. Em caso de dúvida no tamanho dos parafusos e cavilhas, utilize a régua ao final da página.
 La separación de los accesorios antes de comenzar el armado facilitará el mismo. En caso de duda sobre el tamaño de los tornillos y taquetes, utilice la regla al pie de página.

K23		Handle Puxador Gola 15mm / Tirador	381 mm	2
o5		Flanged head screw Parafuso flangeado / Tornillo de cabeza flangeada	3,5x14 mm	6



ASSEMBLY MONTAGEM / ARMADO

02

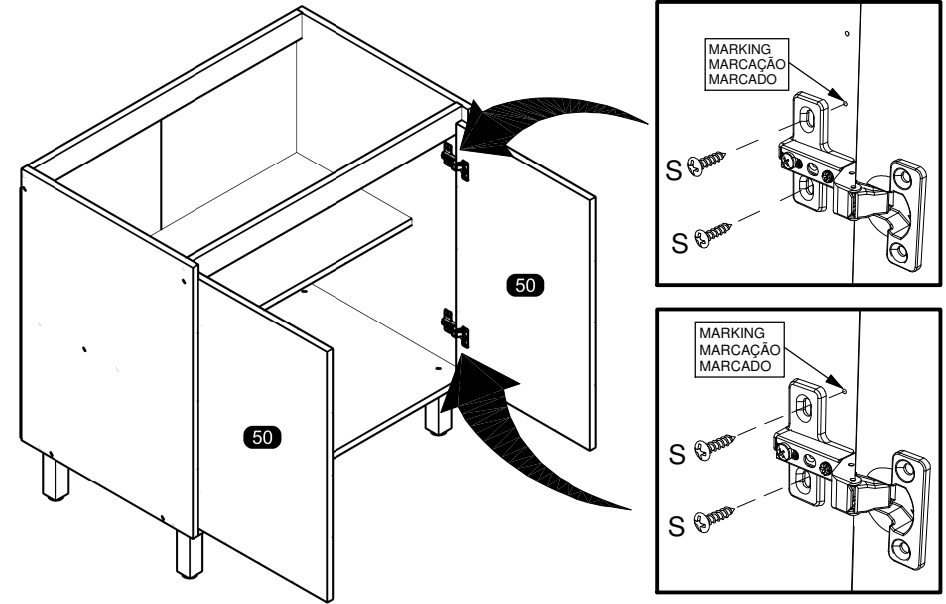

PRE-ASSEMBLY PRÉ-MONTAGEM / PRE ARMADO

01

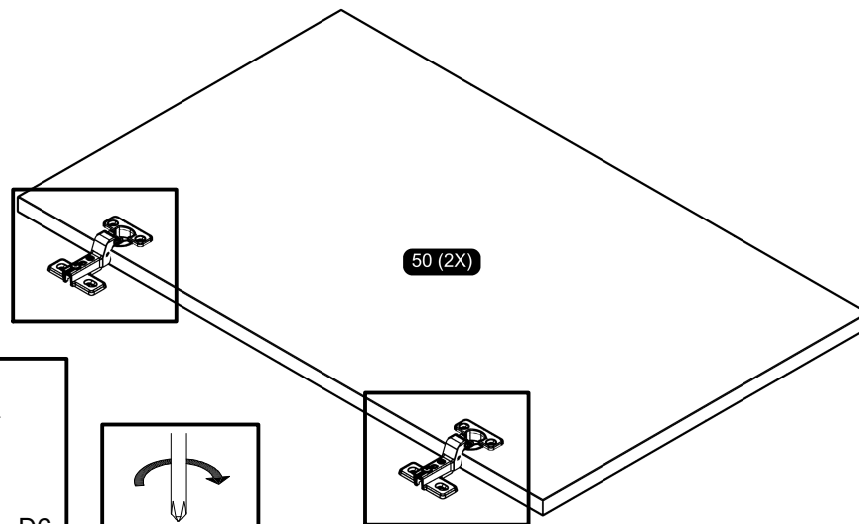

03

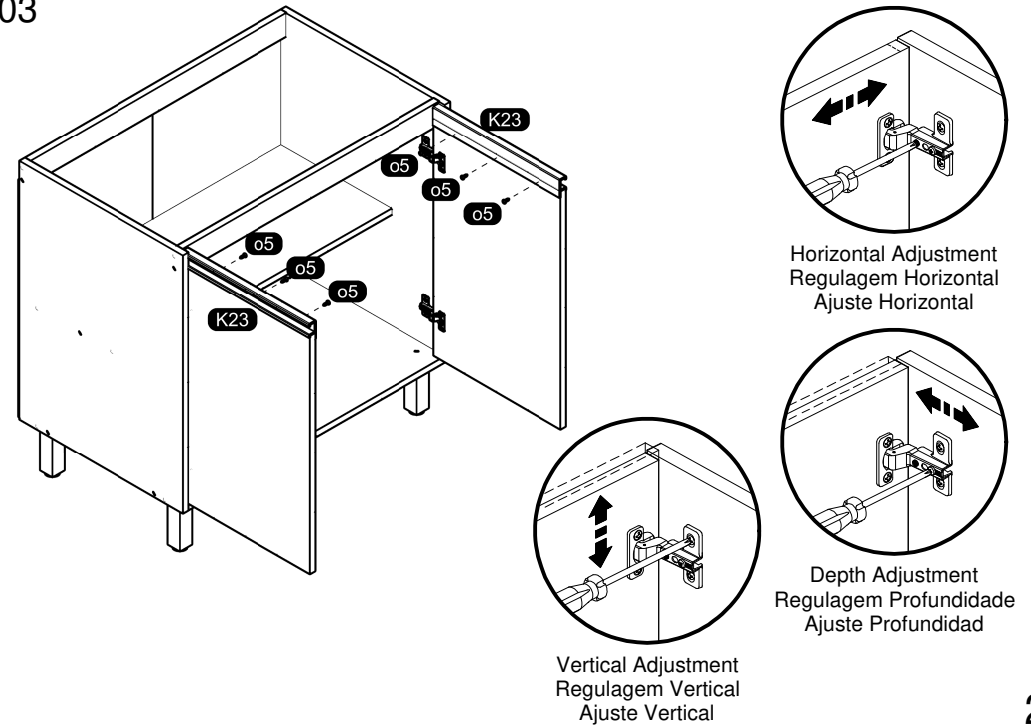

ASSEMBLY INSTRUCTIONS MANUAL DE MONTAGEM / INSTRUCCIONES DE ARMADO

| Revise
| Revisão
| Revisión

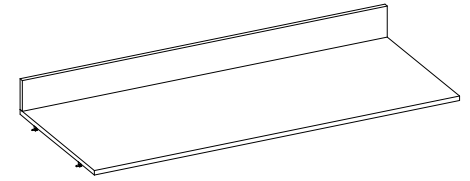

YOU WILL NEED VOCÊ VAI PRECISAR DE / USTED NECESITARÁ

Tools not supplied
Ferramentas não fornecidas / Herramientas no incluidas

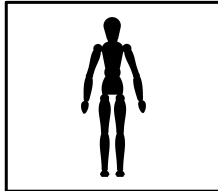

1 Person
1 Pessoa
1 Persona

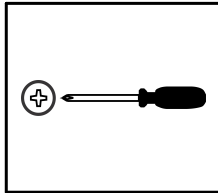

Screwdriver Phillips
Chave Phillips
Destornillador cruz

PARTS IDENTIFICATION IDENTIFICAÇÃO DAS PEÇAS / IDENTIFICACIÓN DE LAS PIEZAS

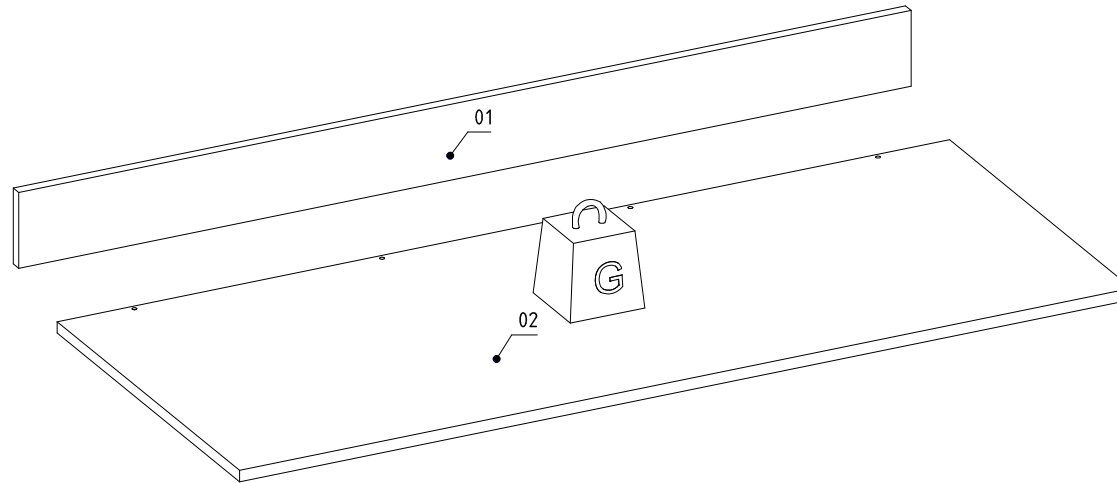

Nº	Measures_Inches	Medidas_cm	Qty./Qtd.
01	47 1/4 x 3 7/8 x 5/8	120.0 x 10.0 x 1.5	1
02	47 1/4 x 19 1/4 x 5/8	120.0 x 49.0 x 1.5	1



MAXIMUM RECOMMENDED WEIGHT
BEING THIS EVENLY DISTRIBUTED.

PESO MÁXIMO RECOMENDADO SENDO
ESTE DISTRIBUÍDO UNIFORMEMENTE.



PESO MÁXIMO RECOMENDADO SIENDO
ESTE UNIFORMEMENTE DISTRIBUIDO.

	LB	KG
G	33	15

IDENTIFICATION OF ACCESSORIES IDENTIFICAÇÃO DOS ACESSÓRIOS/ IDENTIFICACIÓN DE ACCESORIOS



The separation of the accessories before you start the assembly will facilitate the same. In case of doubt on the size of the screws and bolts, use the ruler to bottom of page.
 A separação dos acessórios antes de iniciar a montagem facilitará a mesma. Em caso de dúvida no tamanho dos parafusos e cavilhas, utilize a régua ao final da página.
 La separación de los accesorios antes de comenzar el armado facilitará el mismo. En caso de duda sobre el tamaño de los tornillos y taquetes, utilice la regla al pie de página.

D		Flat head screw Parafuso chato / Tornillo de cabeza plana	4,0x40 mm	4
S		Pan head screw Parafuso panela / Tornillo de pan	3,5x14 mm	8
Y18		Zamac bracket Cantoneira zamac/ Suporte de zamac	13x13 mm	4

PRE-ASSEMBLE PRÉ-MONTAGEM / PRE ARMADO

01

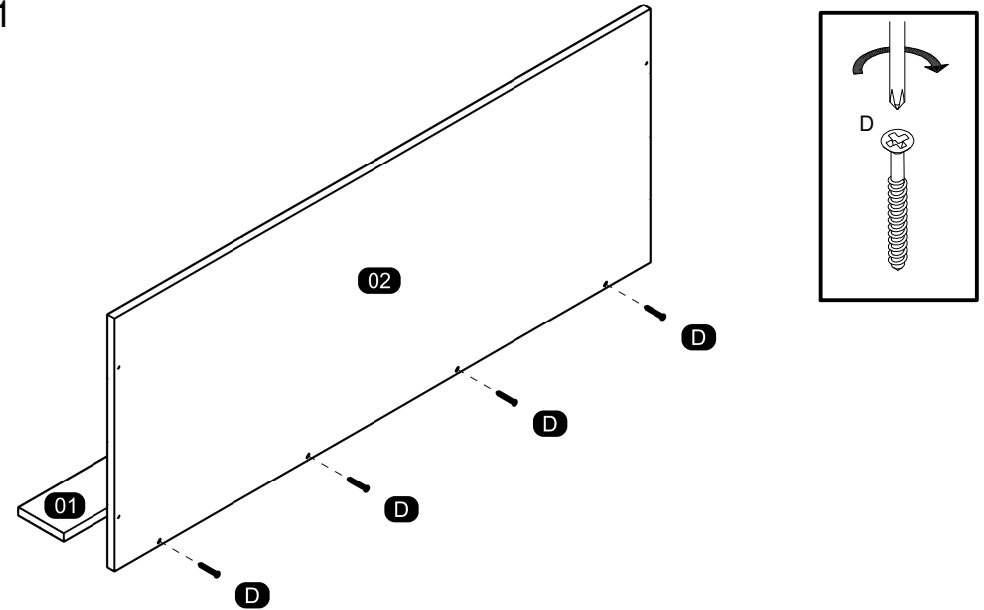

02

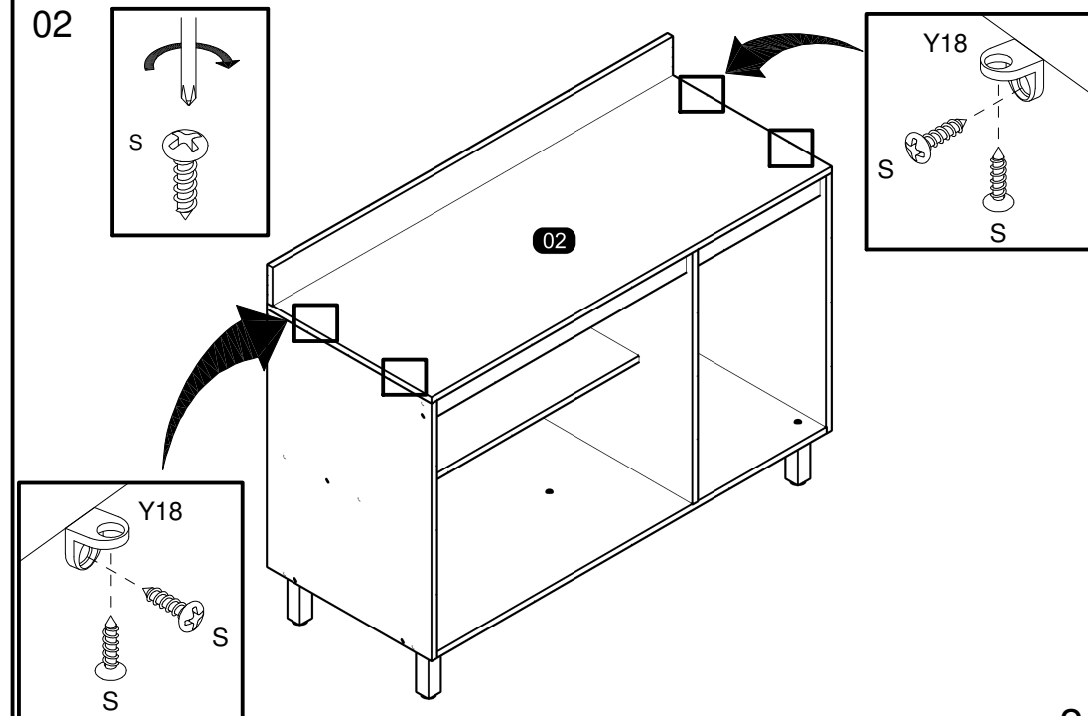

ASSEMBLY INSTRUCTIONS MANUAL DE MONTAGEM / INSTRUCCIONES DE ARMADO

Reference
Referência
Referencia

Revise
Revisão
Revisión

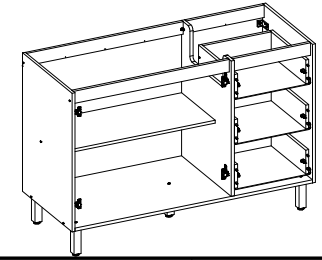

YOU WILL NEED VOCÊ VAI PRECISAR DE / USTED NECESITARÁ

Tools not supplied
Ferramentas não fornecidas / Herramientas no incluidas

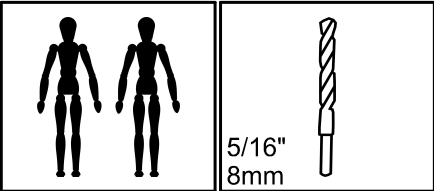

2 People
2 Pessoas
2 Personas

Drill bit
Broca
Taladro

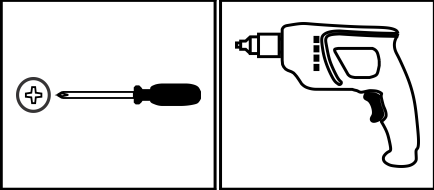

Screwdriver Phillips
Chave Phillips
Destornillador cruz

Drill machine
Furadeira
Taladro

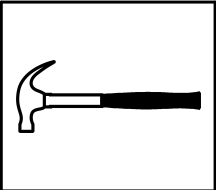

Hammer
Martelo
Martillo

 MAXIMUM RECOMMENDED WEIGHT BEING THIS EVENLY DISTRIBUTED.
PESO MÁXIMO RECOMENDADO SENDO ESTE DISTRIBUÍDO UNIFORMEMENTE.
PESO MÁXIMO RECOMENDADO SIENDO ESTE UNIFORMEMENTE DISTRIBUIDO.

	LB	KG
C	6	3
D	11	5
F	22	10

PARTS IDENTIFICATION IDENTIFICAÇÃO DAS PEÇAS / IDENTIFICACIÓN DE LAS PIEZAS

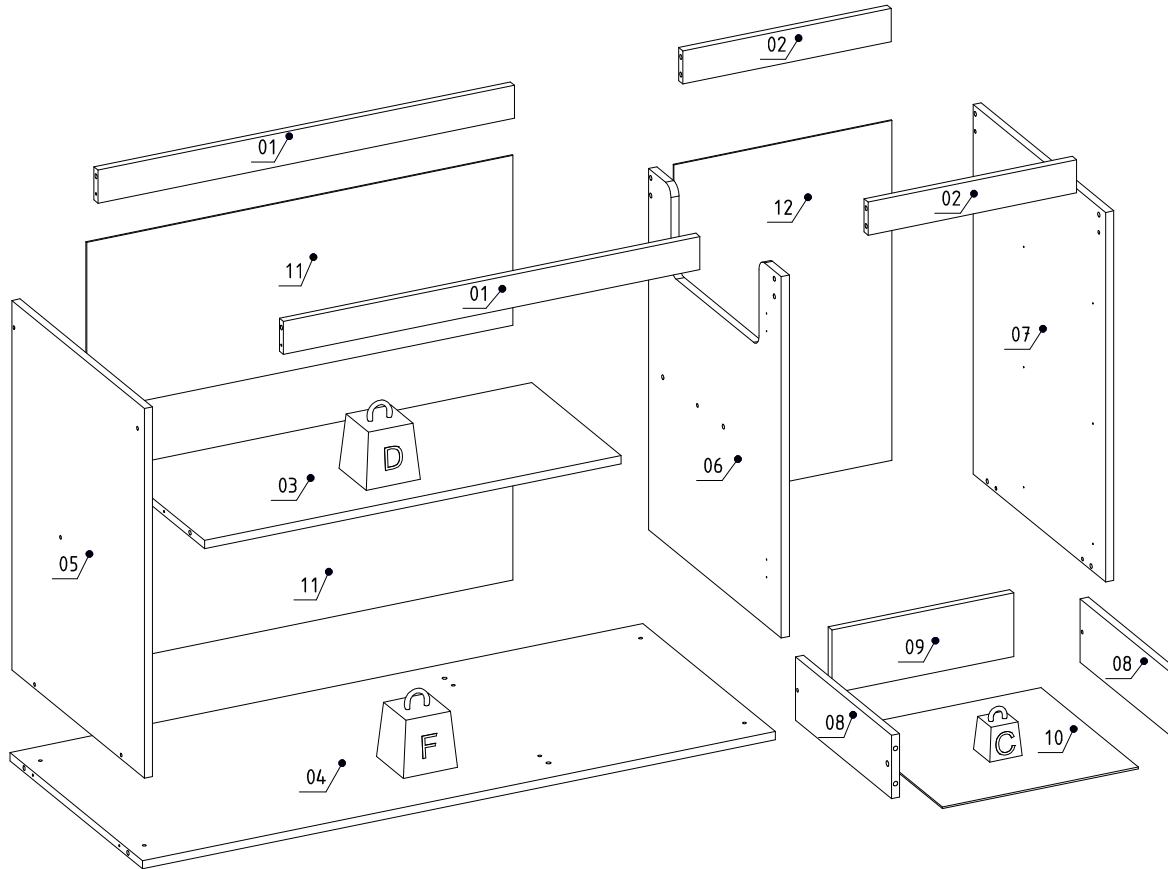

Nº	Measures_Inches	Medidas_cm	Qty./Qtd.
01	30 3/8 x 2 3/8 x 5/8	77.0 x 6.0 x 1.5	2
02	15 1/8 x 2 3/8 x 5/8	38.5 x 6.0 x 1.5	2
03	30 3/8 x 13 x 5/8	77.0 x 33.0 x 1.5	1
04	46 1/8 x 19 1/4 x 5/8	117.0 x 49.0 x 1.5	1
05	26 3/8 x 19 1/4 x 5/8	67.0 x 49.0 x 1.5	1
06	25 3/4 x 19 1/4 x 5/8	65.5 x 49.0 x 1.5	1
07	26 3/8 x 19 1/4 x 5/8	67.0 x 49.0 x 1.5	1
08	14 x 4 1/2 x 5/8	35.5 x 11.5 x 1.5	6
09	13 1/4 x 4 1/2 x 5/8	33.6 x 11.5 x 1.5	3
10	14 1/4 x 14 1/8 x 1/8	36.2 x 36.0 x 0.3	3
11	31 x 12 1/8 x 1/8	78.8 x 30.8 x 0.3	2
12	24 1/4 x 15 7/8 x 1/8	61.6 x 40.3 x 0.3	1

IDENTIFICATION OF ACCESSORIES IDENTIFICAÇÃO DOS ACESSÓRIOS/ IDENTIFICACIÓN DE ACCESORIOS



The separation of the accessories before you start the assembly will facilitate the same. In case of doubt on the size of the screws and bolts, use the ruler at the bottom of the page.
 A separação dos acessórios antes de iniciar a montagem facilitará a mesma. Em caso de dúvida no tamanho dos parafusos e cavilhas, utilize a régua ao final da página.
 La separación de los accesorios antes de comenzar el armado facilitará el mismo. En caso de duda sobre el tamaño de los tornillos y taquetes, utilice la regla al pie de página.

A		Flanged head screw Parafuso flangeado / Tornillo de cabeza flangeada	5,0x60 mm	2
A3		Trapeze Trapézio / Trapecio	-	6
A23		Foot Pé Quadrado FP / Pie	140 mm	5
B3		Bushing Bucha expansiva / Tapón	8x50 mm	2
C		Flanged head screw Parafuso flangeado / Tornillo de cabeza flangeada	4,5x45 mm	5
C1		Metal claw Garra de metal / Garra metal	-	8
D		Flat head screw Parafuso chato / Tornillo de cabeza plana	4,0x40 mm	6
D5		Hinge shim Calço dobradiça / Bisagra de calce	-	4
D6		Metal hinge super high Dobradiça super alta / Bisagra alta	26mm	4
E		Wooden dowel Cavilha / Taquete	8x30 mm	26
F		Wooden dowel Cavilha / Taquete	8x50 mm	4
L9		Flat head screw Parafuso chato / Tornillo de cabeza plana	3,5x12 mm	30
L17		Telescopic slide Corrediça telescópica / Corredera telescópica	350 mm	6
M		Bore patch adhesive Tapa furo adesivo / Tapones adhesivo	-	20
N		Nail Prego / Clavo	10x10	66
N5		Support "L" Suporte "L" / Soporte "L"	-	2
O		Flat head screw Parafuso chato / Tornillo de cabeza plana	4,5x45 mm	12
P		Pan head screw Parafuso panela / Tornillo de pan	4,5x25 mm	6
S		Pan head screw Parafuso panela / Tornillo de pan	3,5x14 mm	28
Y18		Zamac bracket Cantoneira zamac/ Suporte de zamac	13x13 mm	4

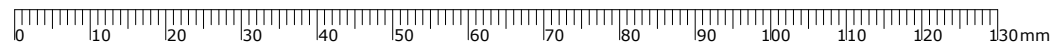

PRE-ASSEMBLE PRÉ-MONTAGEM / PRE ARMADO

01

SEPARATE THE TWO PARTS OF THE METAL SLIDE TO THE ASSEMBLY FOLLOWING THE INSTRUCTIONS BELOW.
 SEPARAR AS DUAS PARTES DA CORREDIÇA METÁLICA PARA A MONTAGEM SEGUINDO AS INSTRUÇÕES ABAIXO.
 SEPARAR LAS DOS PARTES DE LA CORREDERA DE METAL PARA EL ARMADO Y SEGUIR LAS INSTRUCCIONES ABAJO.

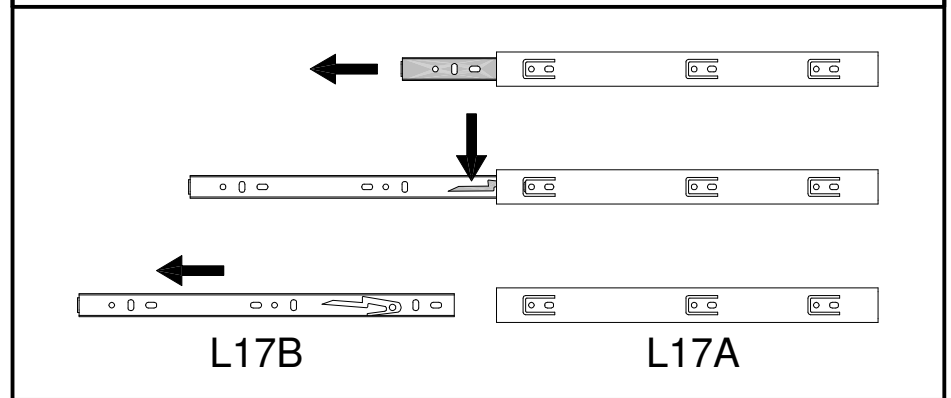

02

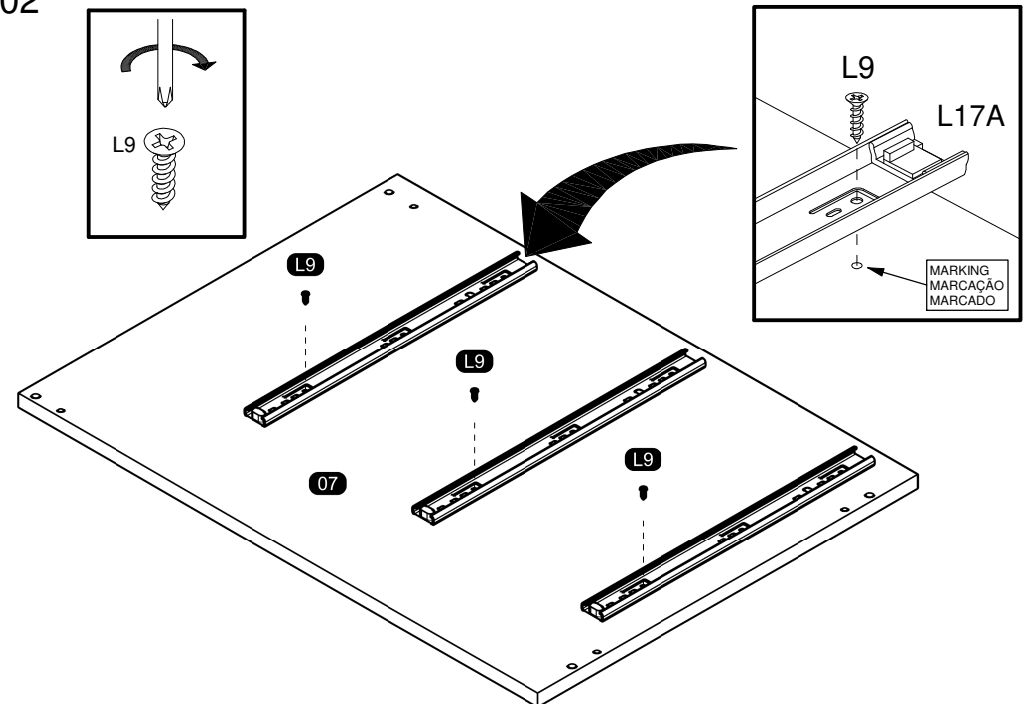

03

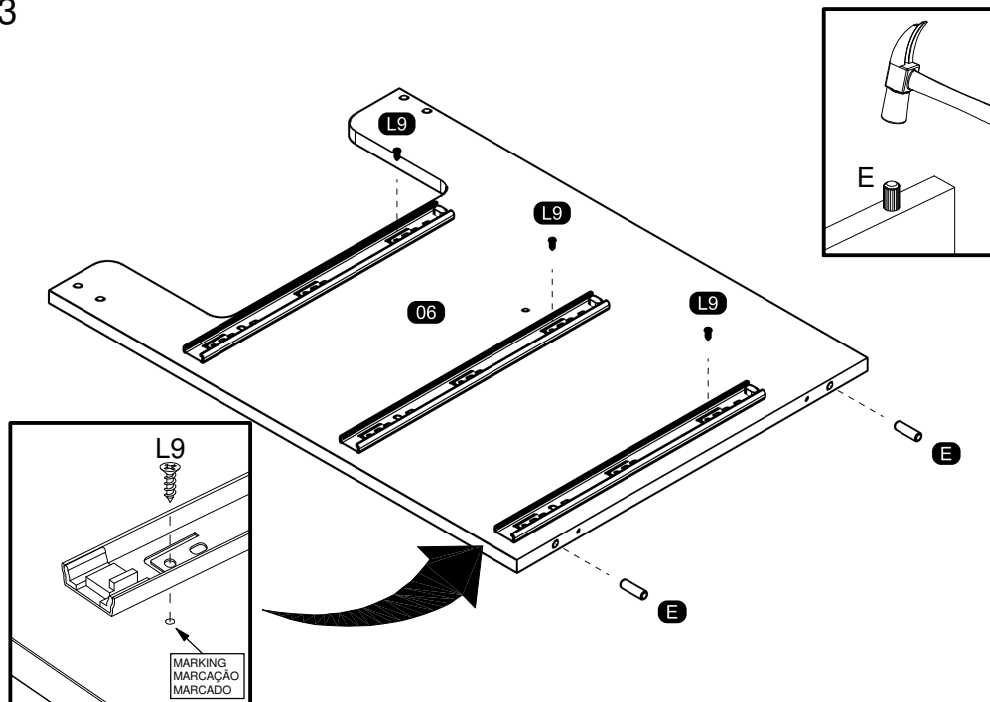

05

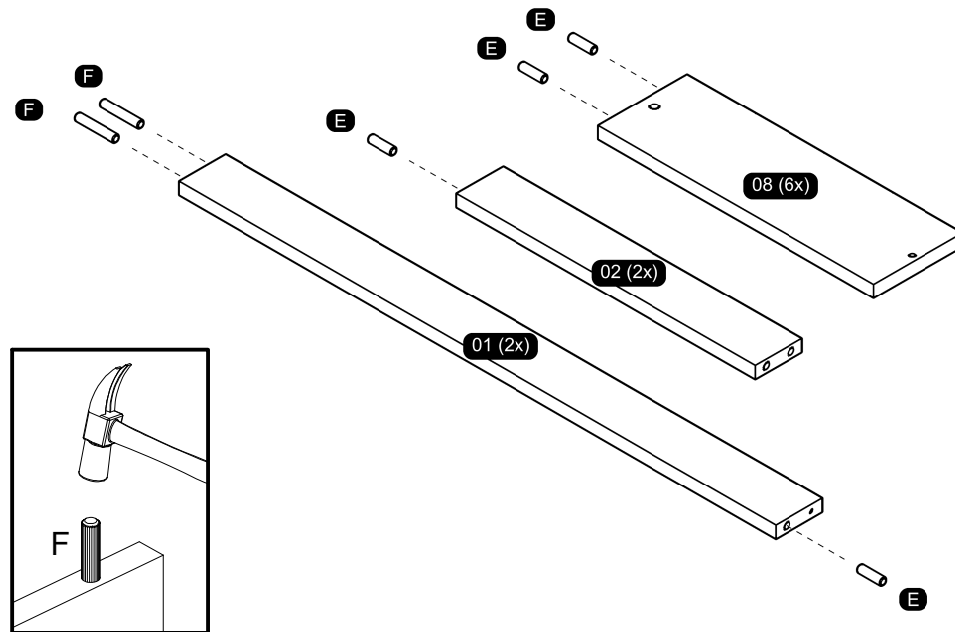

04

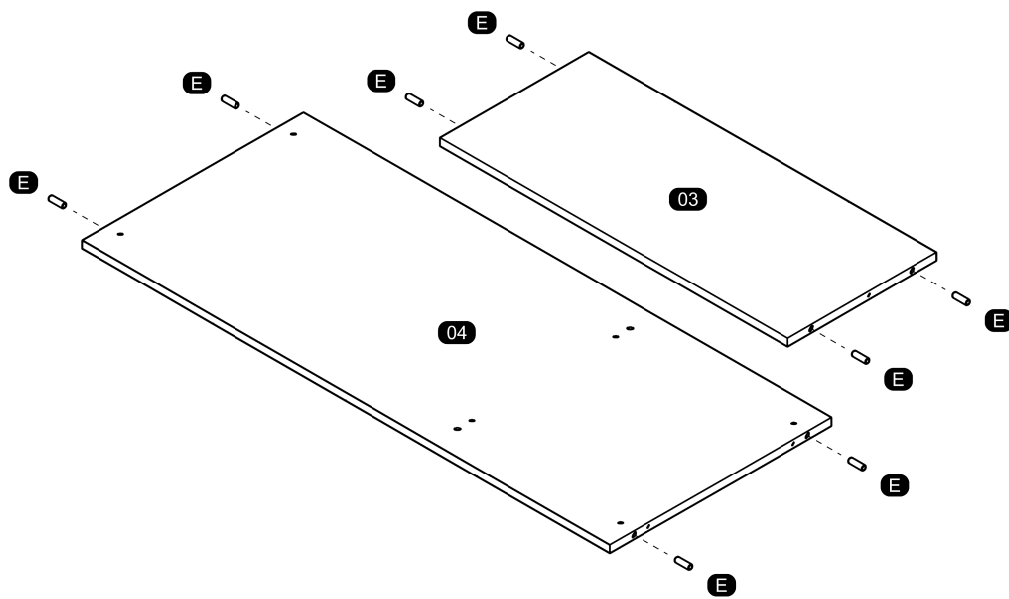

**ASSEMBLY
MONTAGEM / ARMADO**

06

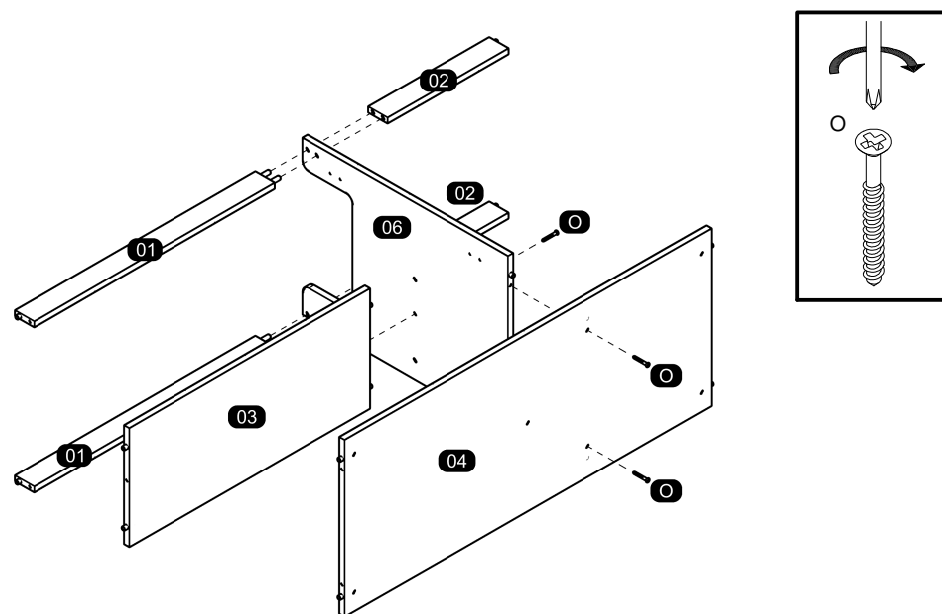

07

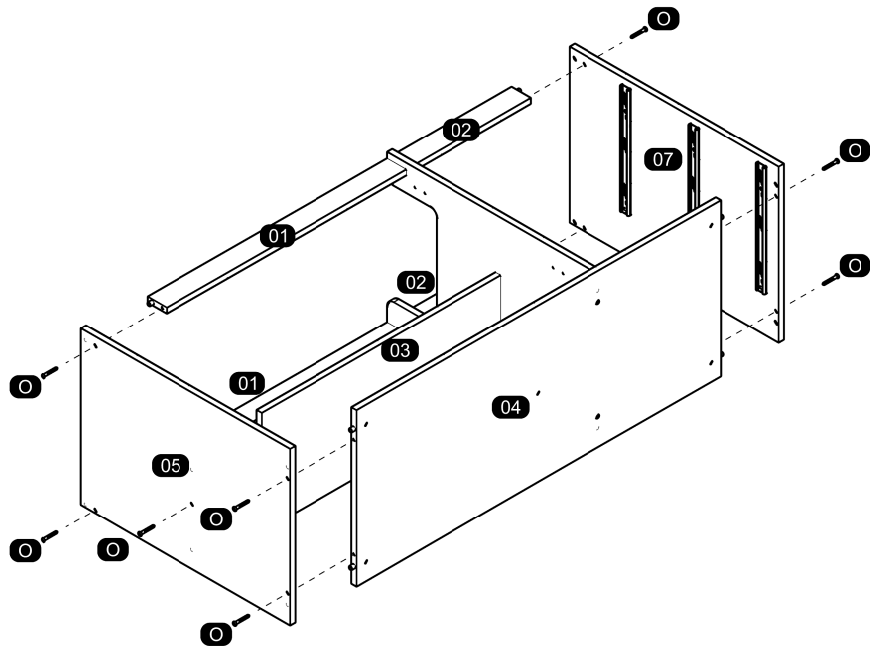

09

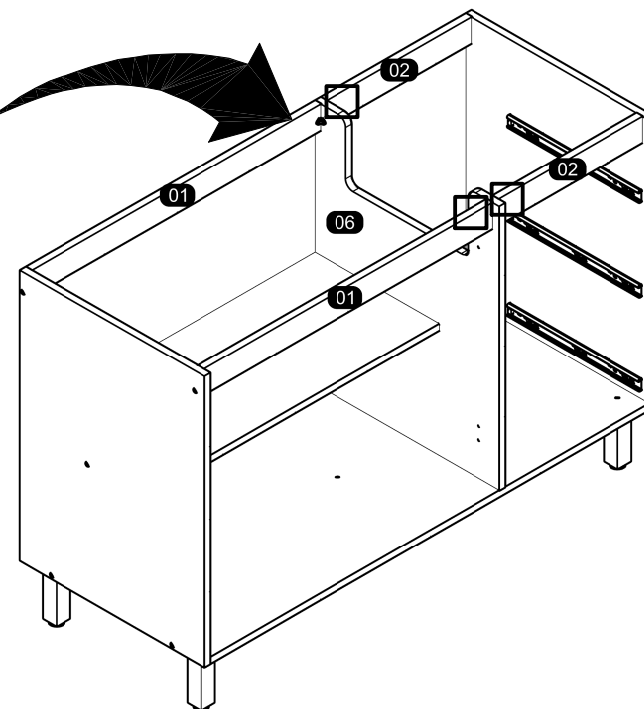
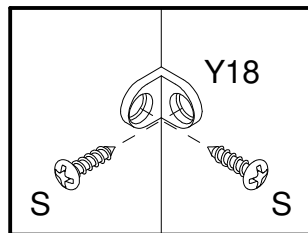

08

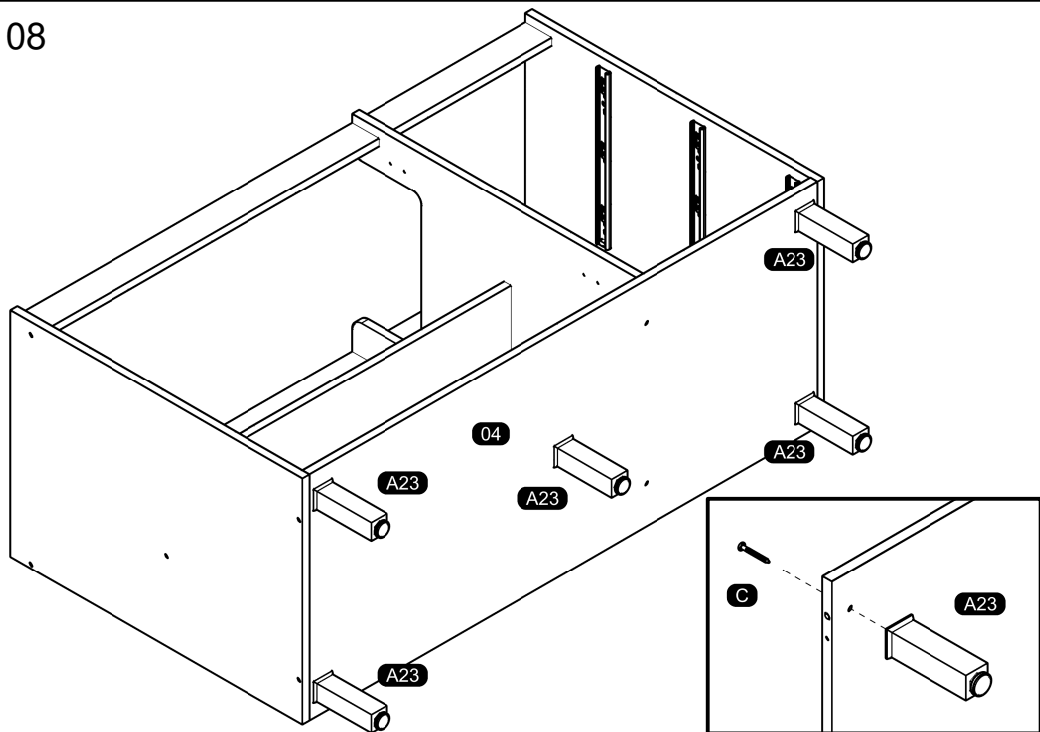

10

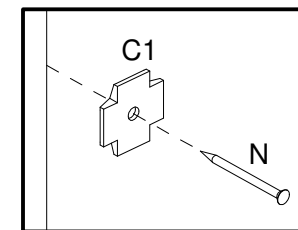
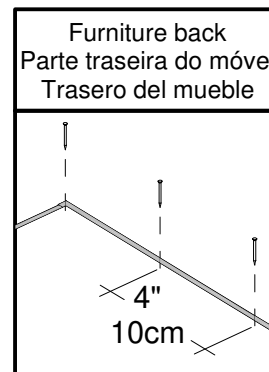
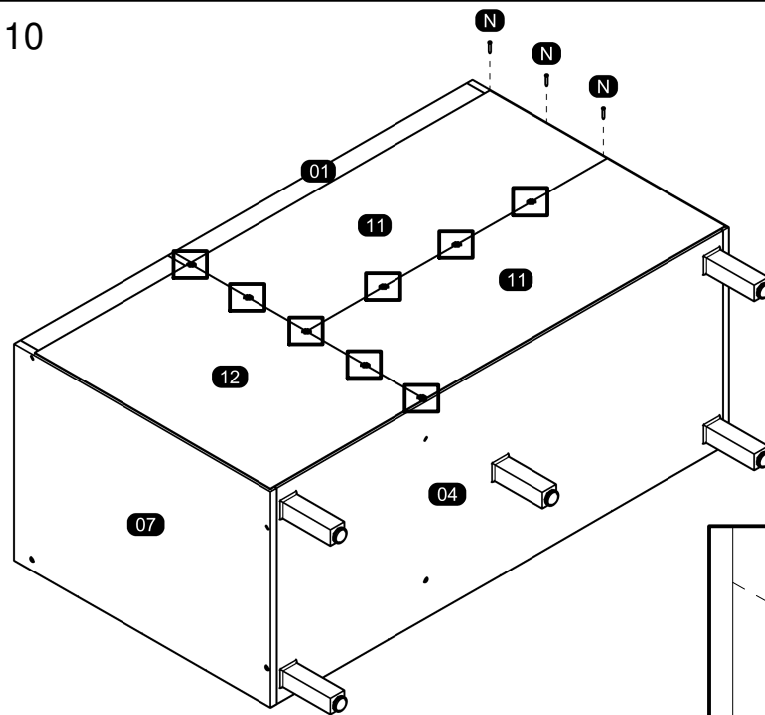

11

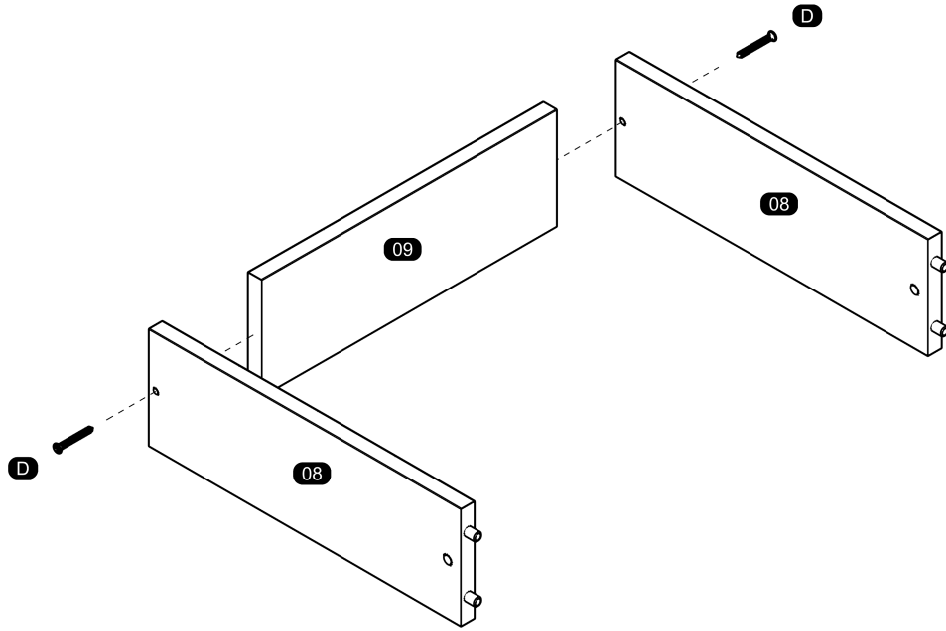

13

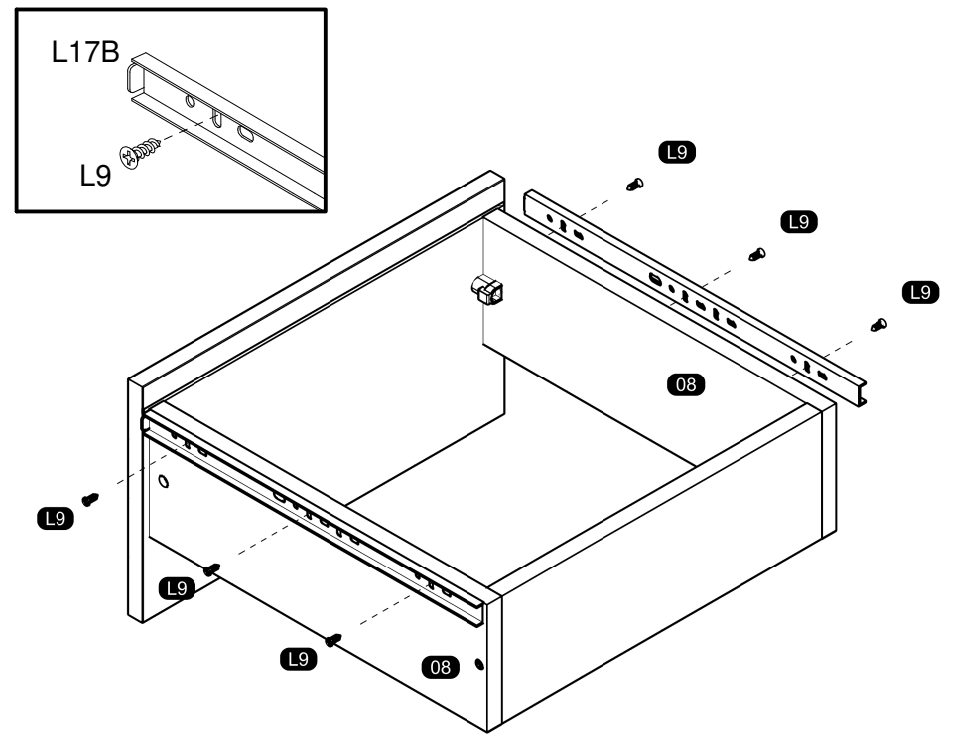

MOUNTING ON THE CHOSEN DRAWER FRONT MODEL
 MONTAGEM NO MODELO DE FRENTE DE GAVETA ESCOLHIDO / MONTAJE EN EL MODELO DE FRENTE DE CAJÓN ELEGIDO

12

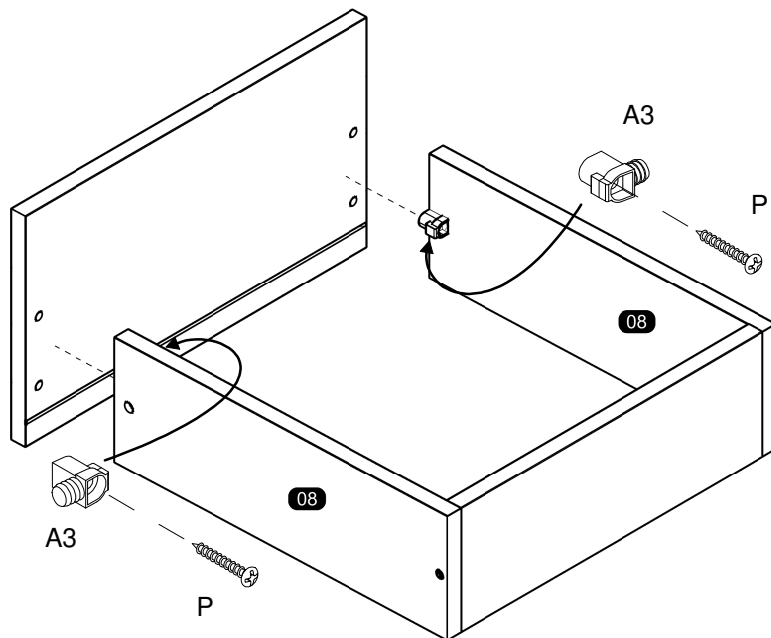

14

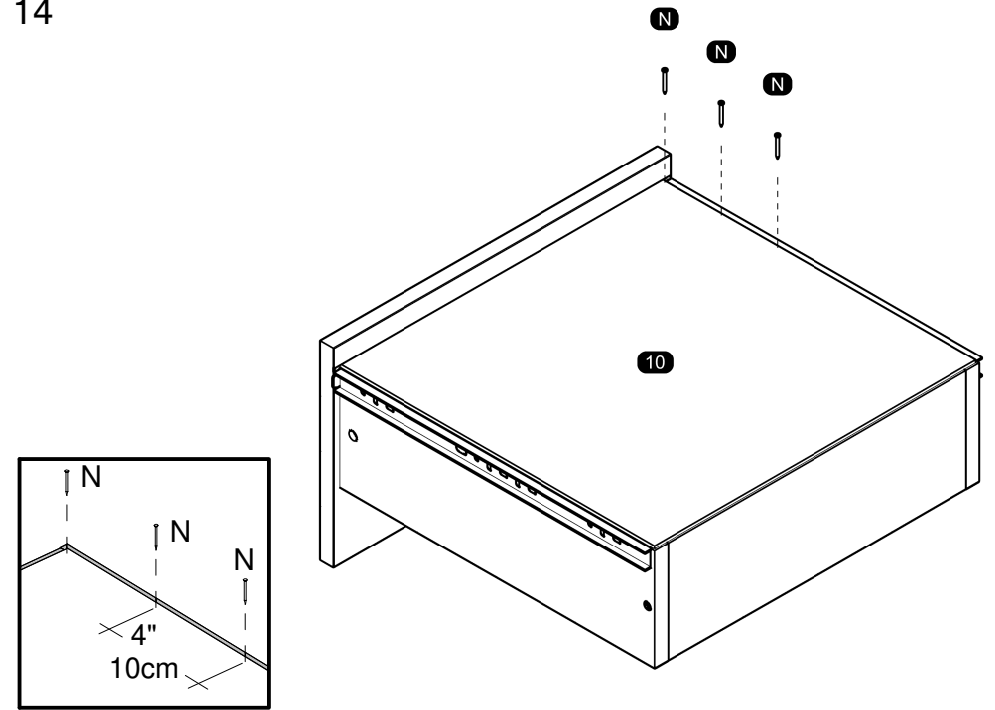

15

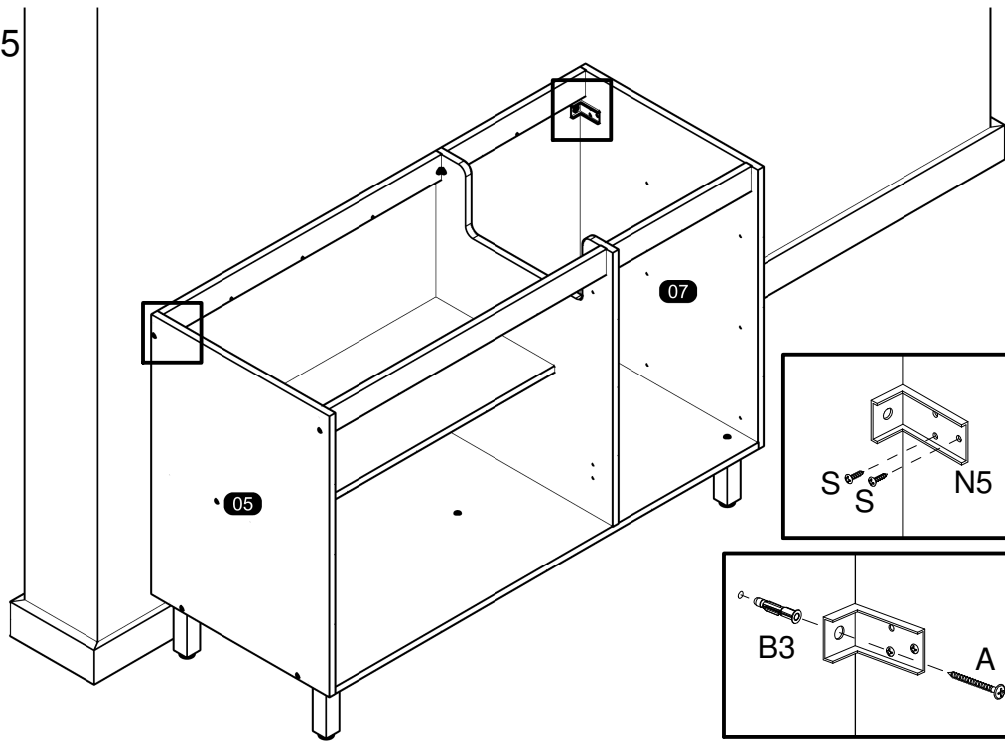

At the end of the assembly, insert the screw cover / hole plugs in the apparent holes.
 Ao final da montagem, insira a(s) tampa(s) de parafuso / tapa furos nos furos que ficarem aparentes.
 Al final del conjunto, coloque la tapa tornillo / tapón plástico en los agujeros que se hagan evidentes.

17

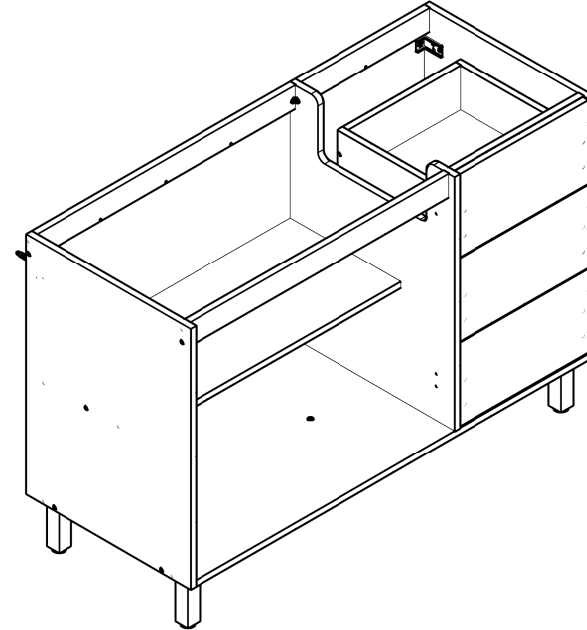

16

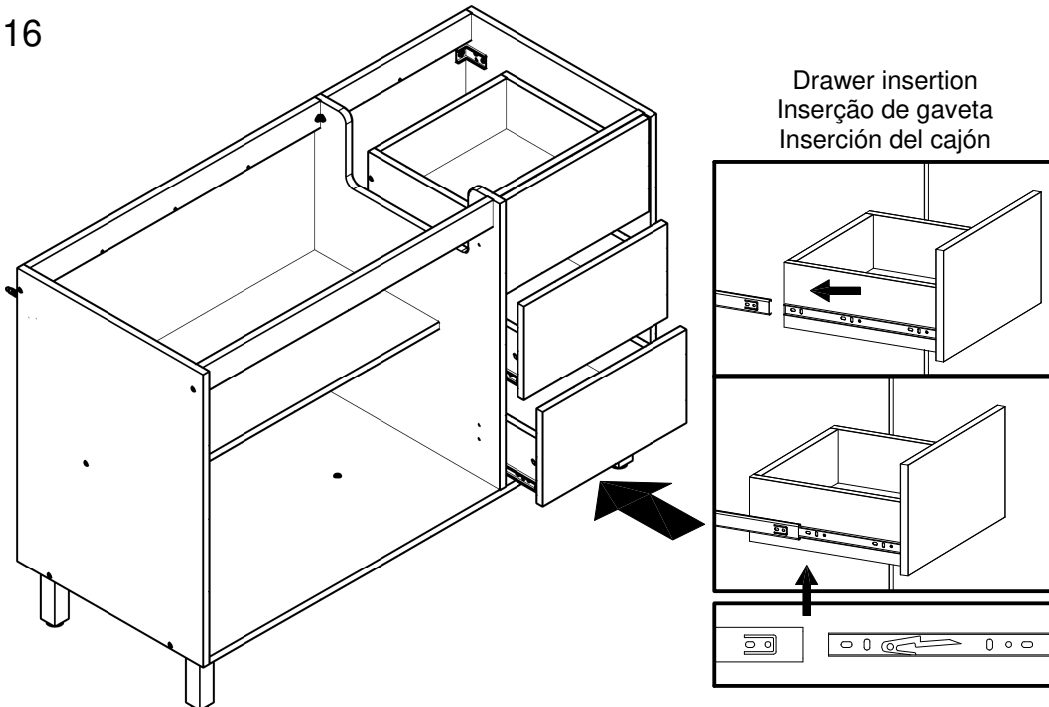

ASSEMBLY INSTRUCTIONS MANUAL DE MONTAGEM / INSTRUCCIONES DE ARMADO

Reference
Referência
Referencia

Revise
Revisão
Revisión

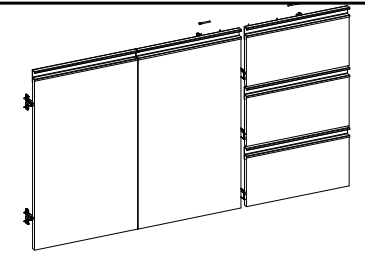

YOU WILL NEED VOCÊ VAI PRECISAR DE / USTED NECESITARÁ

Tools not supplied
Ferramentas não fornecidas / Herramientas no incluidas

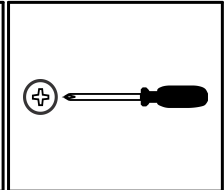
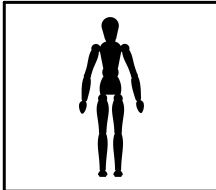

1 Person
1 Pessoa
1 Persona

Screwdriver Phillips
Chave Phillips
Destornillador cruz

PARTS IDENTIFICATION IDENTIFICAÇÃO DAS PEÇAS / IDENTIFICACIÓN DE LAS PIEZAS

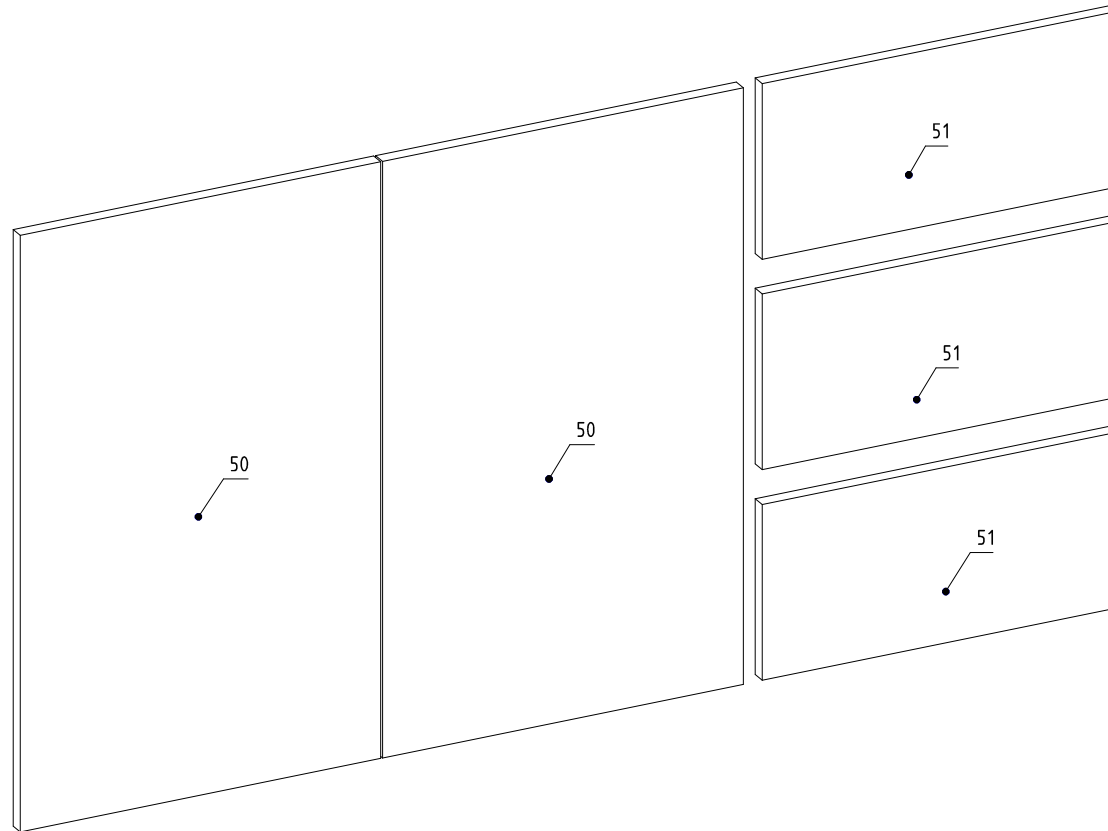

Nº	Measures_Inches	Medidas_cm	Qty./Qtd.
50	24 3/8 x 15 x 5/8	61.8 x 38.1 x 1.5	2
51	15 x 7 1/8 x 5/8	38.0 x 18.2 x 1.5	3



MAXIMUM RECOMMENDED WEIGHT
BEING THIS EVENLY DISTRIBUTED.

PESO MÁXIMO RECOMENDADO SENDO
ESTE DISTRIBUÍDO UNIFORMEMENTE.

PESO MÁXIMO RECOMENDADO SIENDO
ESTE UNIFORMEMENTE DISTRIBUIDO.

—

LB

KG

IDENTIFICATION OF ACCESSORIES IDENTIFICAÇÃO DOS ACESSÓRIOS/ IDENTIFICACIÓN DE ACCESORIOS



The separation of the accessories before you start the assembly will facilitate the same. In case of doubt on the size of the screws and bolts, use the ruler to bottom of page.
 A separação dos acessórios antes de iniciar a montagem facilitará a mesma. Em caso de dúvida no tamanho dos parafusos e cavilhas, utilize a régua ao final da página.
 La separación de los accesorios antes de comenzar el armado facilitará el mismo. En caso de duda sobre el tamaño de los tornillos y taquetes, utilice la regla al pie de página.

K23		Handle Puxador Gola / Tirador	381 mm	5
o5		Flanged head screw Parafuso flangeado / Tornillo de cabeza flangeada	3,5x14 mm	15



PRE-ASSEMBLE PRÉ-MONTAGEM / PRE ARMADO

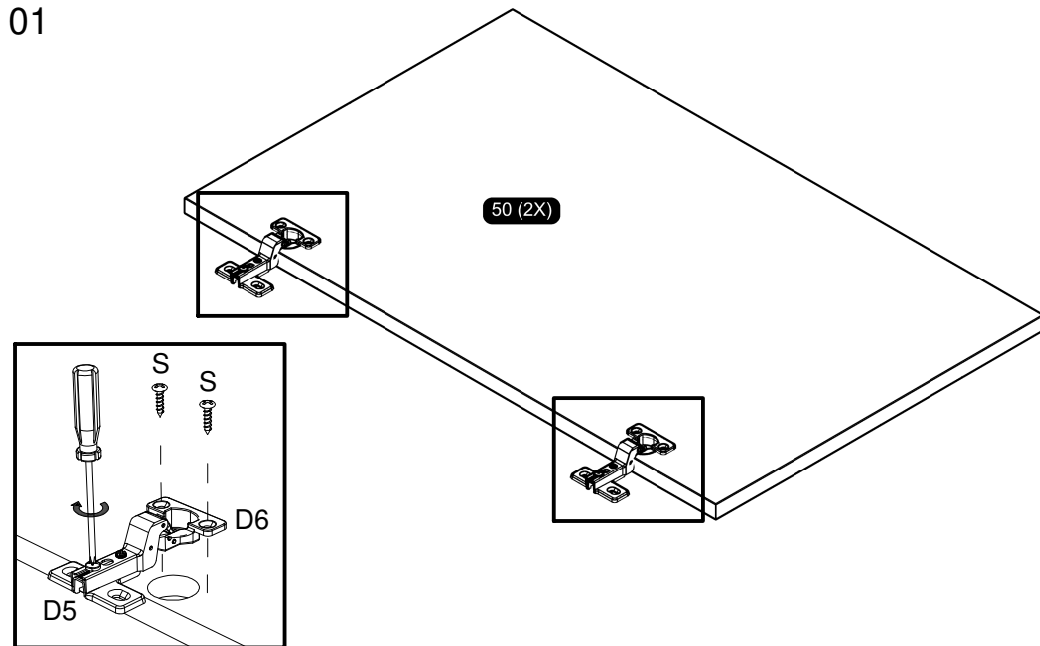

ASSEMBLY MONTAGEM / ARMADO

02

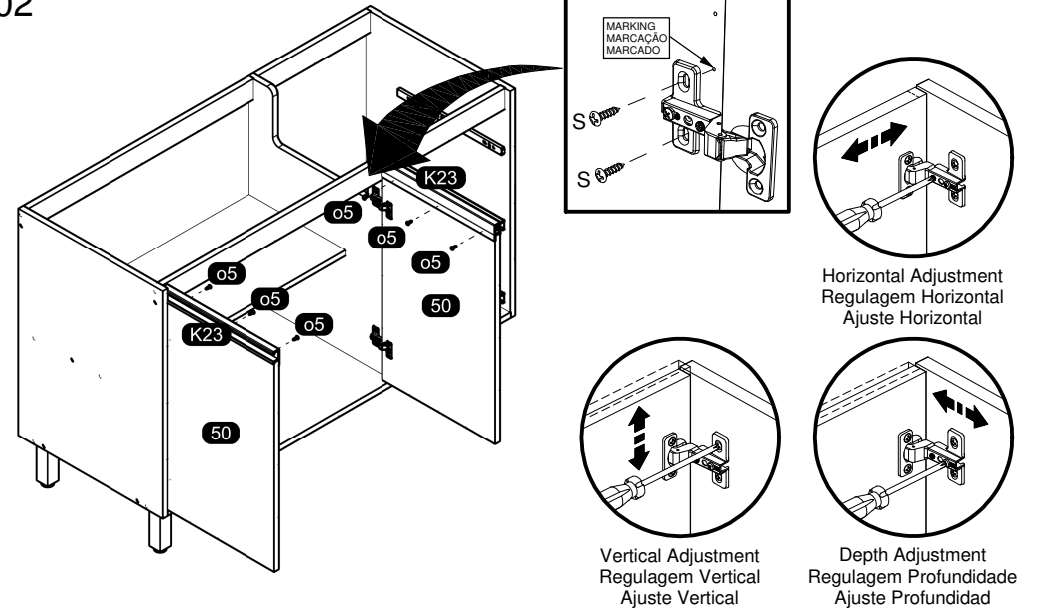

03

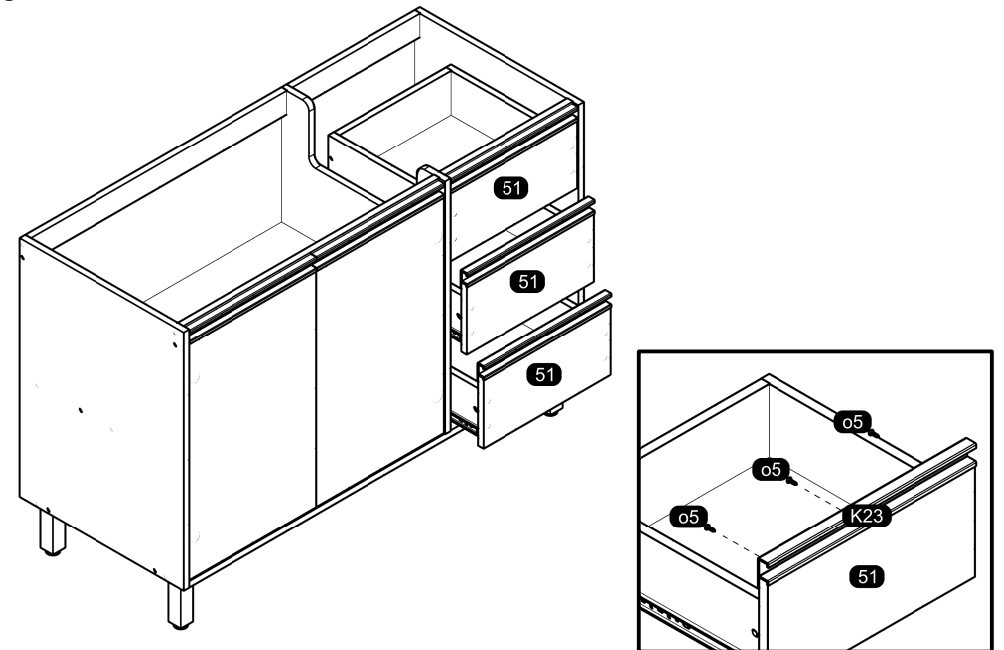

ASSEMBLY INSTRUCTIONS MANUAL DE MONTAGEM / INSTRUCCIONES DE ARMADO

Reference
Referência
Referencia

Revise
Revisão
Revisión

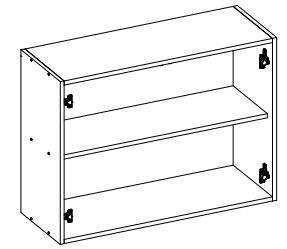

YOU WILL NEED VOCÊ VAI PRECISAR DE / USTED NECESITARÁ

Tools not supplied
Ferramentas não fornecidas / Herramientas no incluidas

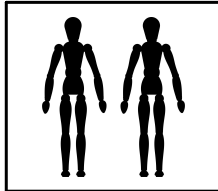

2 People
2 Pessoas
2 Personas

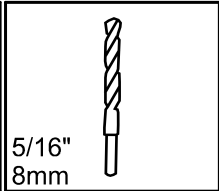

Drill bit
Broca
Taladro

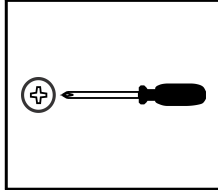

Screwdriver Phillips
Chave Phillips
Destornillador cruz

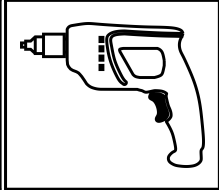

Drill machine
Furadeira
Taladro

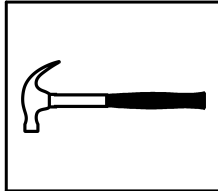

Hammer
Martelo
Martillo



MAXIMUM RECOMMENDED WEIGHT
BEING THIS EVENLY DISTRIBUTED.

PESO MÁXIMO RECOMENDADO SENDO
ESTE DISTRIBUÍDO UNIFORMEMENTE.

PESO MÁXIMO RECOMENDADO SIENDO
ESTE UNIFORMEMENTE DISTRIBUIDO.

	LB	KG
—		
F	22	10

PARTS IDENTIFICATION IDENTIFICAÇÃO DAS PEÇAS / IDENTIFICACIÓN DE LAS PIEZAS

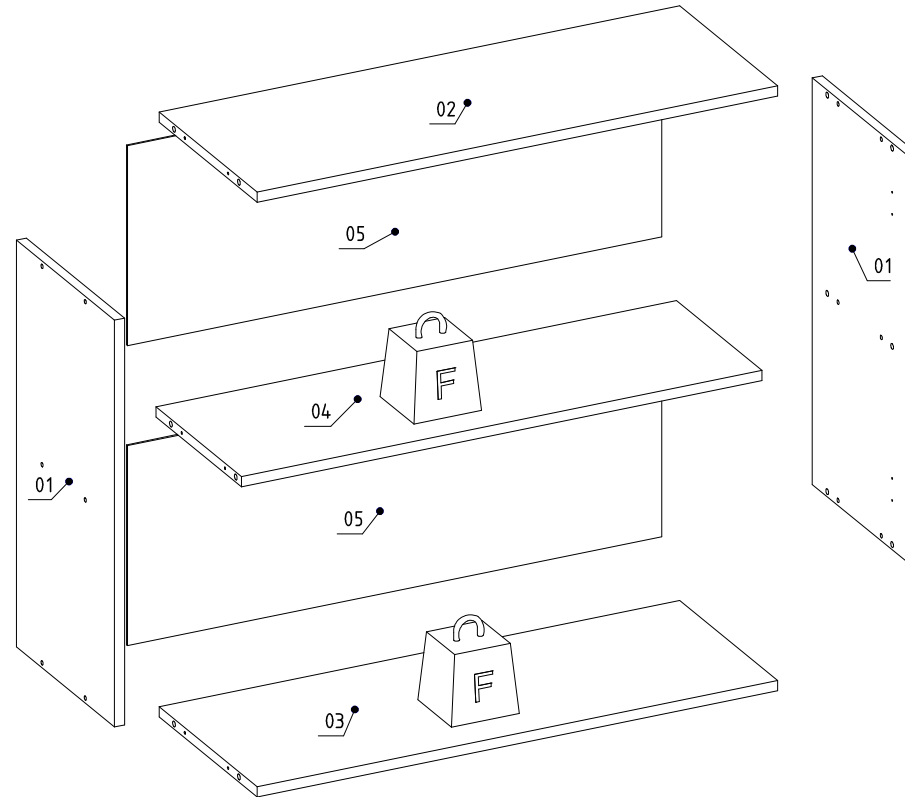

Nº	Measures_Inches	Medidas_cm	Qty./Qtd.
01	11 3/8 x 23 1/4 x 5/8	29.0 x 59.0 x 1.5	2
02	30 3/8 x 11 3/8 x 5/8	77.0 x 29.0 x 1.5	1
03	30 3/8 x 11 3/8 x 5/8	77.0 x 29.0 x 1.5	1
04	30 3/8 x 10 x 5/8	77.0 x 25.3 x 1.5	1
05	31 1/8 x 11 3/8 x 1/8	79.0 x 29.0 x 0.3	2

IDENTIFICATION OF ACCESSORIES IDENTIFICAÇÃO DOS ACESSÓRIOS/ IDENTIFICACIÓN DE ACCESORIOS



The separation of the accessories before you start the assembly will facilitate the same. In case of doubt on the size of the screws and bolts, use the ruler to bottom of page.
 A separação dos acessórios antes de iniciar a montagem facilitará a mesma. Em caso de dúvida no tamanho dos parafusos e cavilhas, utilize a régua ao final da página.
 La separación de los accesorios antes de comenzar el armado facilitará el mismo. En caso de duda sobre el tamaño de los tornillos y taquetes, utilice la regla al pie de página.

A		Flanged head screw Parafuso flangeado / Tornillo de cabeza flangeada	5,0x60 mm	2
B3		Bushing Bucha expansiva / Tapón	8x50 mm	2
B8		Shelf bracket Suporte de prateleira / Soporte de repisa	10x15 mm	2
C1		Metal claw Garra de metal / Garra metal	-	4
D5		Hinge shim Calço dobradiça / Bisagra de calce	-	4
D6		Metal hinge super high Dobradiça super alta / Bisagra alta	26mm	4
E		Wooden dowel Cavilha / Taquete	8x30 mm	12
N		Nail Prego / Clavo	10x10	32
N5		Support "L" Suporte "L" / Soporte "L"	-	2
O		Flat head screw Parafuso chato / Tornillo de cabeza plana	4,5x45 mm	12
S		Pan head screw Parafuso panela / Tornillo de pan	3,5x14 mm	22

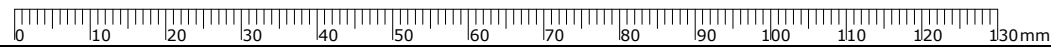

PRE-ASSEMBLE PRÉ-MONTAGEM / PRE ARMADO

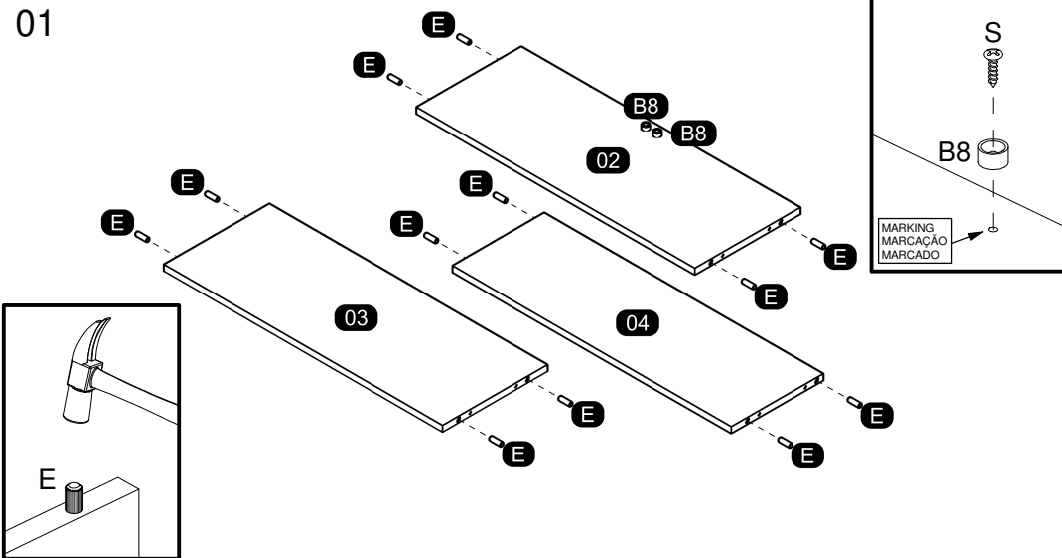

ASSEMBLY MONTAGEM / ARMADO

02

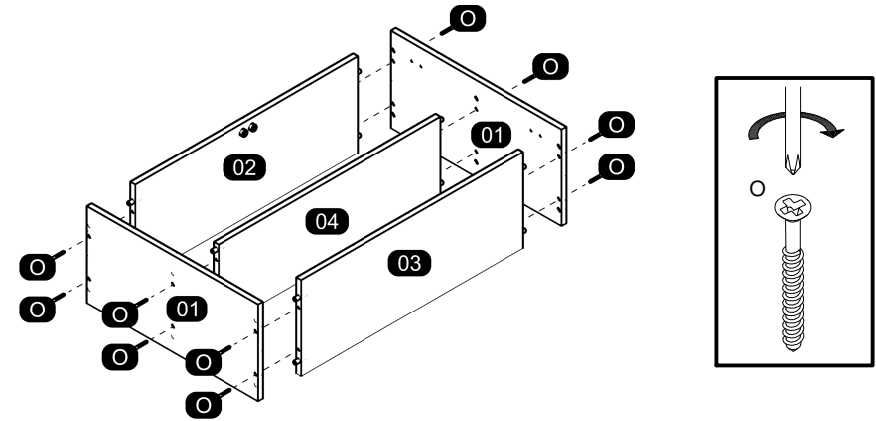

03

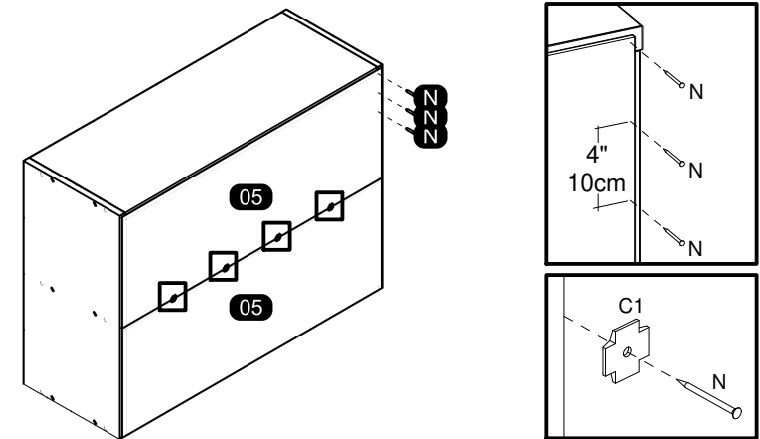

04

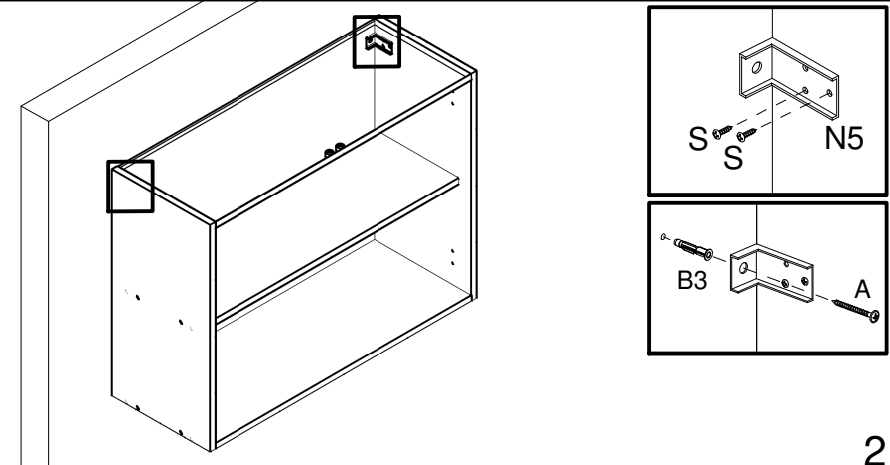

ASSEMBLY INSTRUCTIONS MANUAL DE MONTAGEM / INSTRUCCIONES DE ARMADO

Reference
Referência
Referencia

Revise
Revisão
Revisión

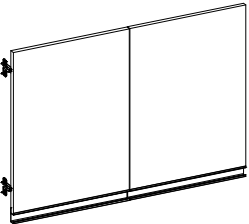

**YOU WILL NEED
VOCÊ VAI PRECISAR DE / USTED NECESITARÁ**

Tools not supplied
Ferramentas não fornecidas / Herramientas no incluidas

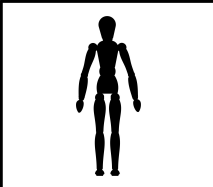

1 Person
1 Pessoa
1 Persona

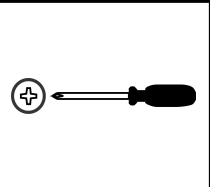

Screwdriver Phillips
Chave Phillips
Destornillador cruz

**PARTS IDENTIFICATION
IDENTIFICAÇÃO DAS PEÇAS / IDENTIFICACIÓN DE LAS PIEZAS**

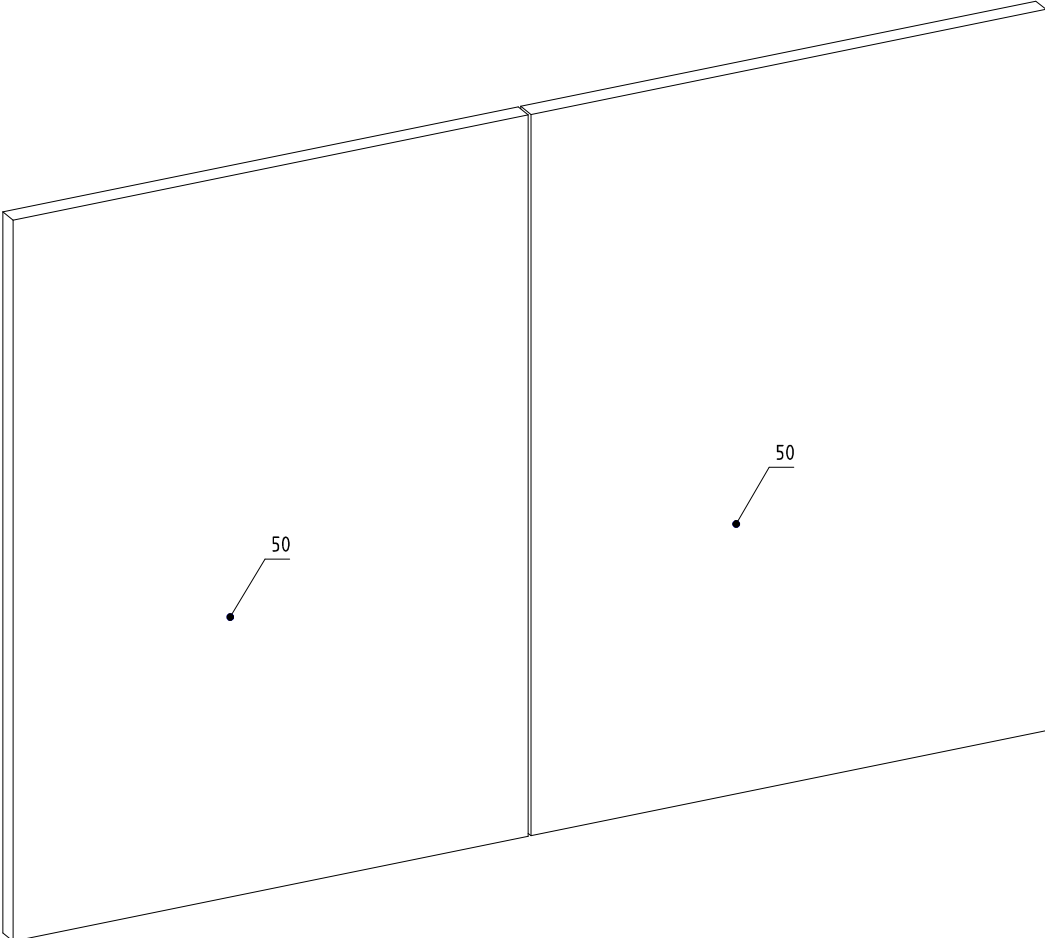

Nº	Measures_Inches	Medidas_cm	Qty./Qtd.
50	20 5/8 x 15 x 5/8	52.3 x 38.1 x 1.5	2

 MAXIMUM RECOMMENDED WEIGHT BEING THIS EVENLY DISTRIBUTED.
PESO MÁXIMO RECOMENDADO SENDO ESTE DISTRIBUÍDO UNIFORMEMENTE.
PESO MÁXIMO RECOMENDADO SIENDO ESTE UNIFORMEMENTE DISTRIBUIDO.

—	LB	KG
---	----	----

IDENTIFICATION OF ACCESSORIES IDENTIFICAÇÃO DOS ACESSÓRIOS/ IDENTIFICACIÓN DE ACCESORIOS



The separation of the accessories before you start the assembly will facilitate the same. In case of doubt on the size of the screws and bolts, use the ruler to bottom of page.
 A separação dos acessórios antes de iniciar a montagem facilitará a mesma. Em caso de dúvida no tamanho dos parafusos e cavilhas, utilize a régua ao final da página.
 La separación de los accesorios antes de comenzar el armado facilitará el mismo. En caso de duda sobre el tamaño de los tornillos y taquetes, utilice la regla al pie de página.

K23		Handle Puxador Gola / Tirador	381 mm	2
o5		Flanged head screw Parafuso flangeado / Tornillo de cabeza flangeada	3,5x14 mm	6



PRE-ASSEMBLE PRÉ-MONTAGEM / PRE ARMADO

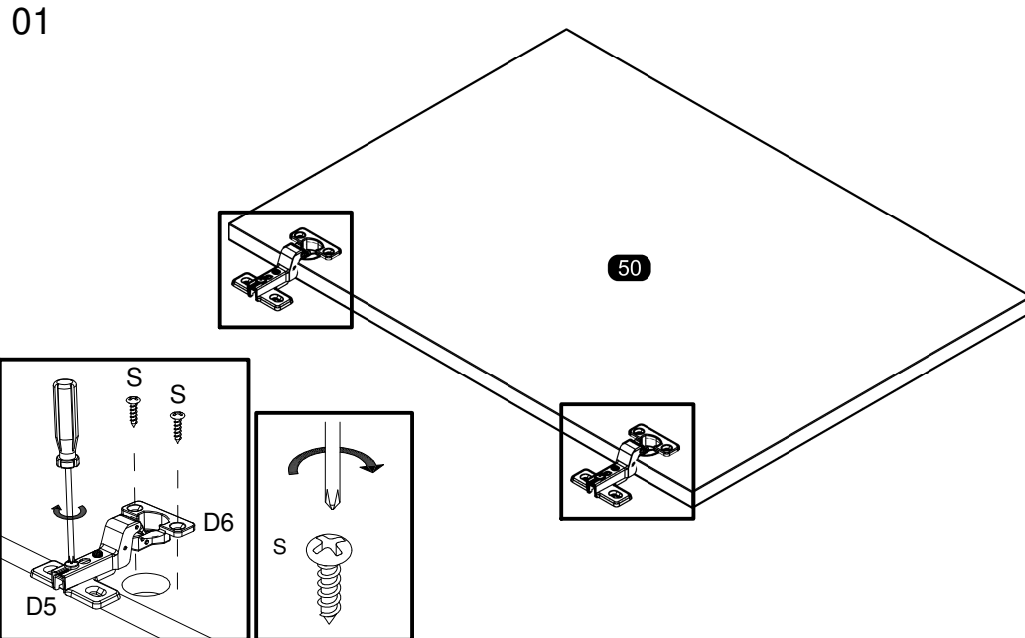

ASSEMBLY MONTAGEM / ARMADO

02

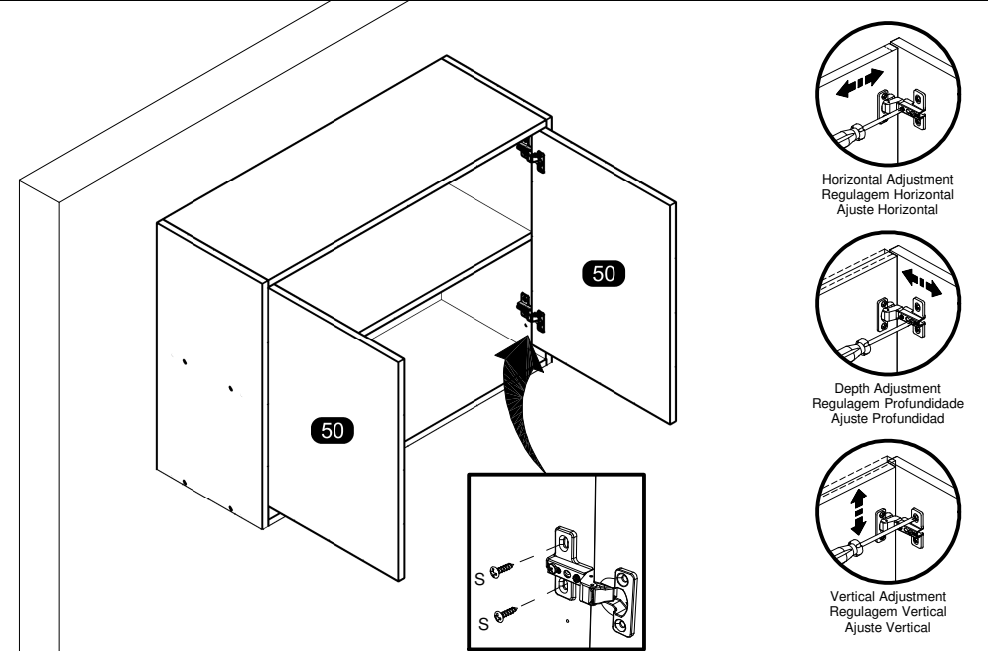

03

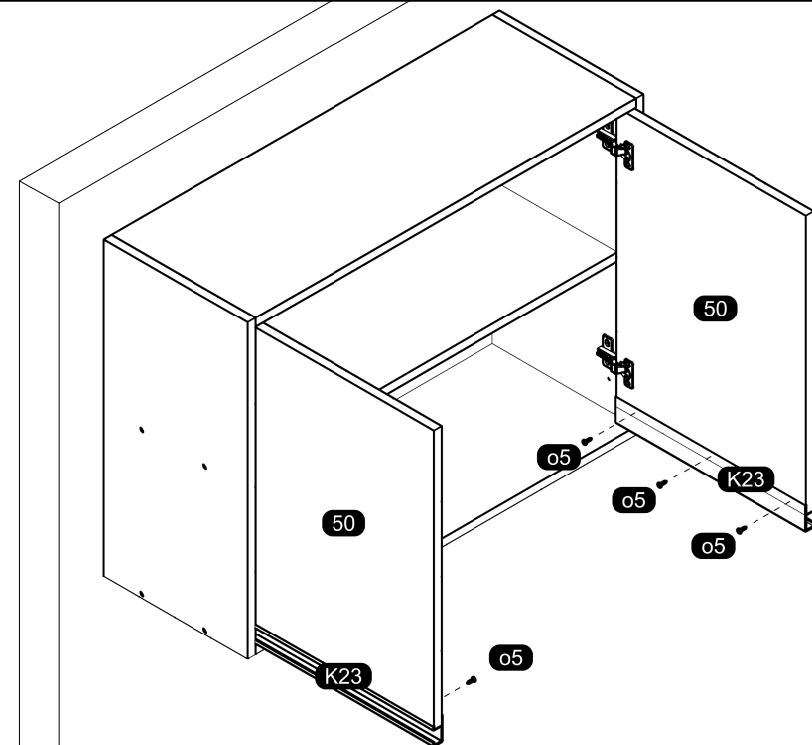

ASSEMBLY INSTRUCTIONS MANUAL DE MONTAGEM / INSTRUCCIONES DE ARMADO

Reference
Referência
Referencia

Revise
Revisão
Revisión

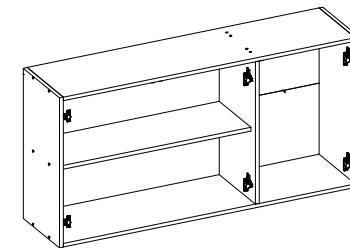

YOU WILL NEED VOCÊ VAI PRECISAR DE / USTED NECESITARÁ

Tools not supplied
Ferramentas não fornecidas / Herramientas no incluidas

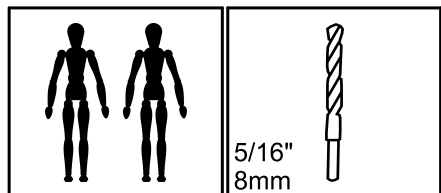

2 People
2 Pessoas
2 Personas

Drill bit
Broca
Taladro

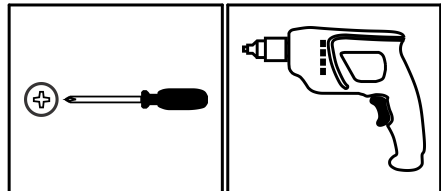

Screwdriver Phillips
Chave Phillips
Destornillador cruz

Drill machine
Furadeira
Taladro

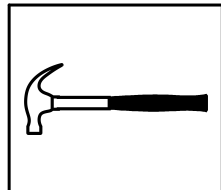

Hammer
Martelo
Martillo

 MAXIMUM RECOMMENDED WEIGHT BEING THIS EVENLY DISTRIBUTED.
PESO MÁXIMO RECOMENDADO SENDO ESTE DISTRIBUÍDO UNIFORMEMENTE.
PESO MÁXIMO RECOMENDADO SIENDO ESTE UNIFORMEMENTE DISTRIBUIDO.

	LB	KG
D	11	5
F	22	10

PARTS IDENTIFICATION IDENTIFICAÇÃO DAS PEÇAS / IDENTIFICACIÓN DE LAS PIEZAS

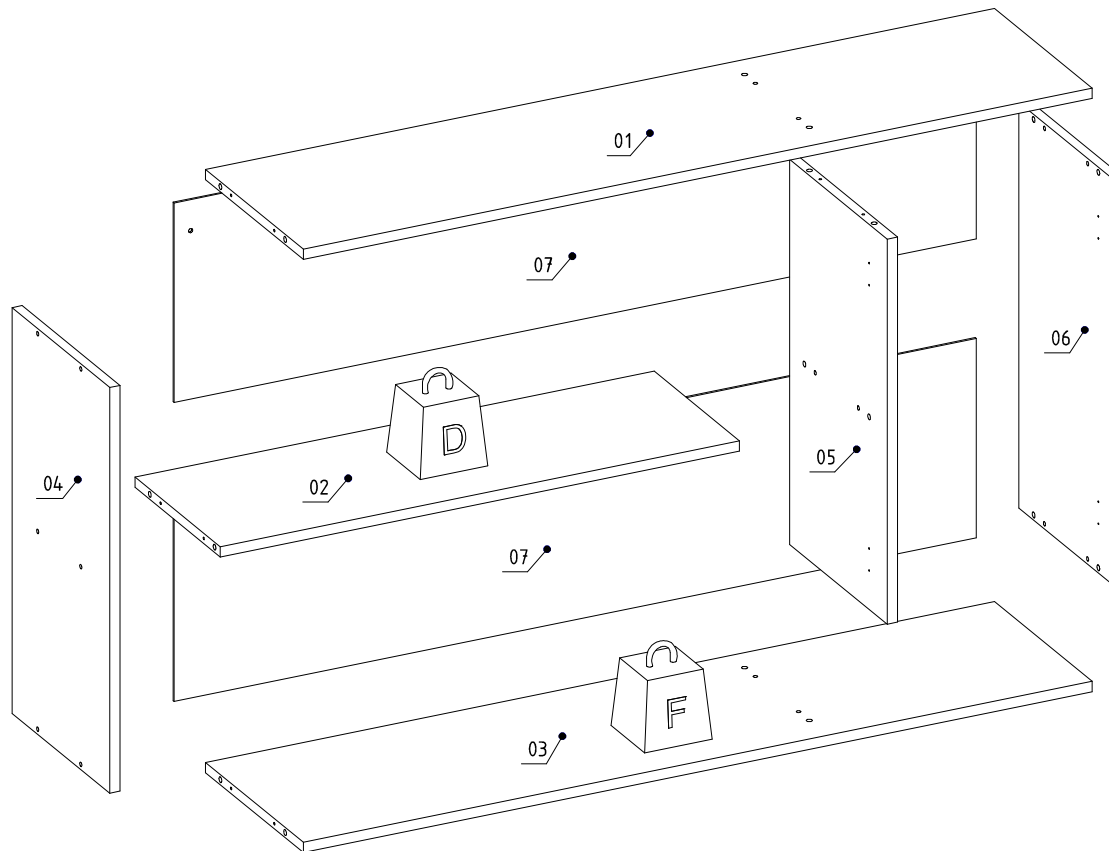

Nº	Measures_Inches	Medidas_cm	Qty./Qtd.
01	46 1/8 x 11 3/8 x 5/8	117.0 x 29.0 x 1.5	1
02	30 3/8 x 10 x 5/8	77.0 x 25.3 x 1.5	1
03	46 1/8 x 11 3/8 x 5/8	117.0 x 29.0 x 1.5	1
04	11 3/8 x 23 1/4 x 5/8	29.0 x 59.0 x 1.5	1
05	11 3/8 x 22 x 5/8	29.0 x 56.0 x 1.5	1
06	11 3/8 x 23 1/4 x 5/8	29.0 x 59.0 x 1.5	1
07	46 7/8 x 11 3/8 x 1/8	119.0 x 29.0 x 0.3	2

IDENTIFICATION OF ACCESSORIES IDENTIFICAÇÃO DOS ACESSÓRIOS/ IDENTIFICACIÓN DE ACCESORIOS



The separation of the accessories before you start the assembly will facilitate the same. In case of doubt on the size of the screws and bolts, use the ruler at bottom of page.
 A separação dos acessórios antes de iniciar a montagem facilitará a mesma. Em caso de dúvida no tamanho dos parafusos e cavilhas, utilize a régua ao final da página.
 La separación de los accesorios antes de comenzar el armado facilitará el mismo. En caso de duda sobre el tamaño de los tornillos y taquetes, utilice la regla al pie de página.

A		Flanged head screw Parafuso flangeado / Tornillo de cabeza flangeada	5,0x60 mm	3
B3		Bushing Bucha expansiva / Tapón	8x50 mm	3
B8		Shelf bracket Suporte de prateleira / Suporte de repisa	10x15 mm	3
C1		Metal claw Garra de metal / Garra metal	-	4
D5		Hinge shim Calço dobradiça / Bisagra de calce	-	6
D6		Metal hinge super high Dobradiça super alta / Bisagra alta	26mm	6
E		Wooden dowel Cavilha / Taquete	8x30 mm	16
N		Nail Prego / Clavo	10x10	40
N5		Support "L" Suporte "L" / Soporte "L"	-	3
O		Flat head screw Parafuso chato / Tornillo de cabeza plana	4,5x45 mm	16
S		Pan head screw Parafuso panela / Tornillo de pan	3,5x14 mm	33



PRE-ASSEMBLE PRÉ-MONTAGEM / PRE ARMADO

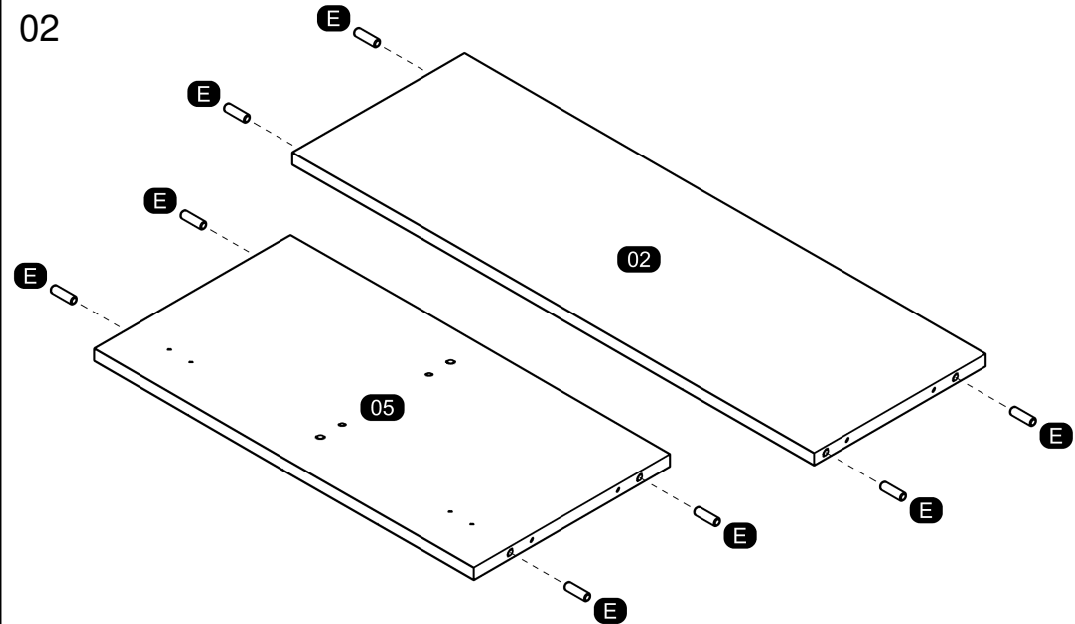
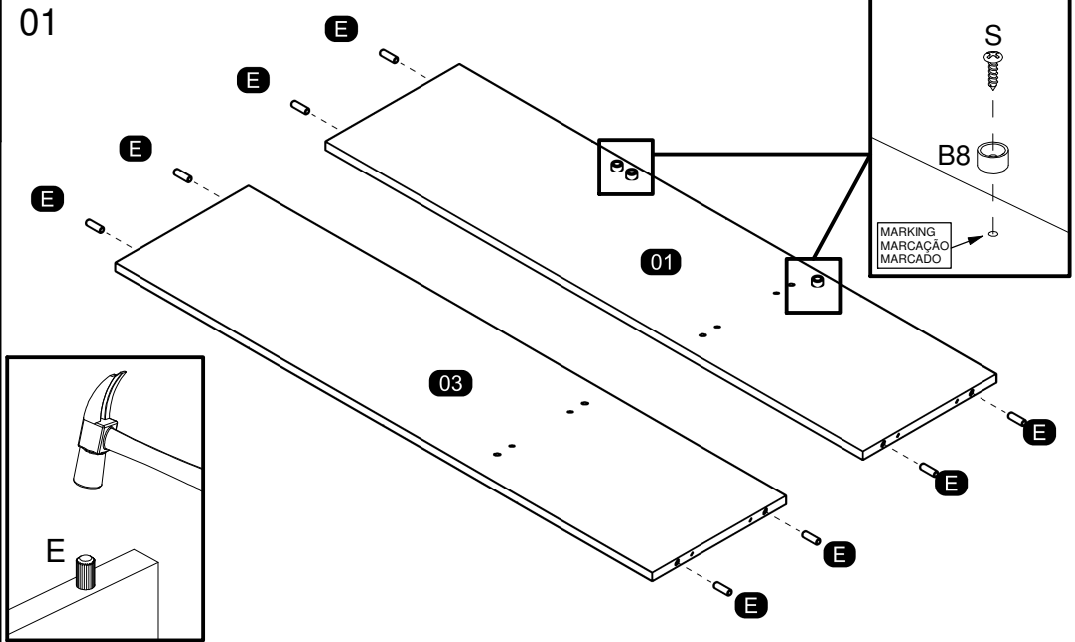

**ASSEMBLY
MONTAGEM / ARMADO**

03

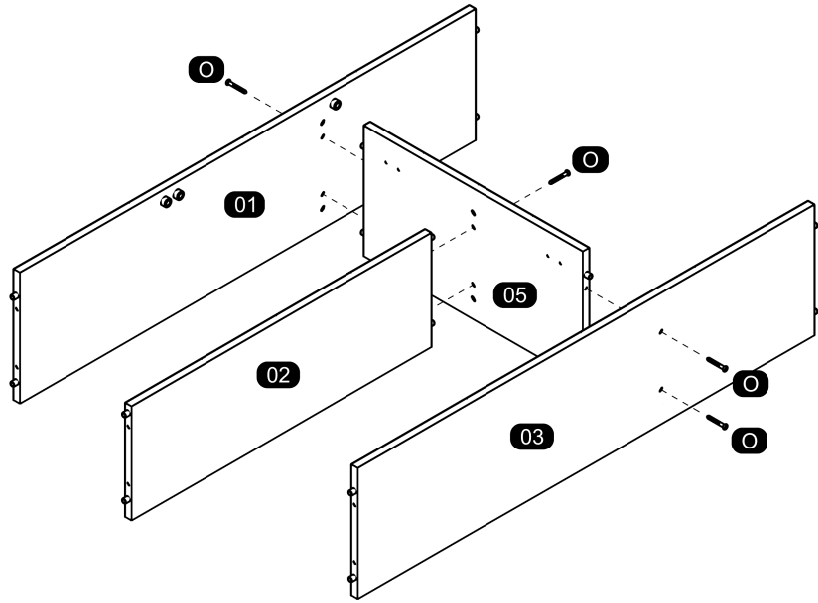

05

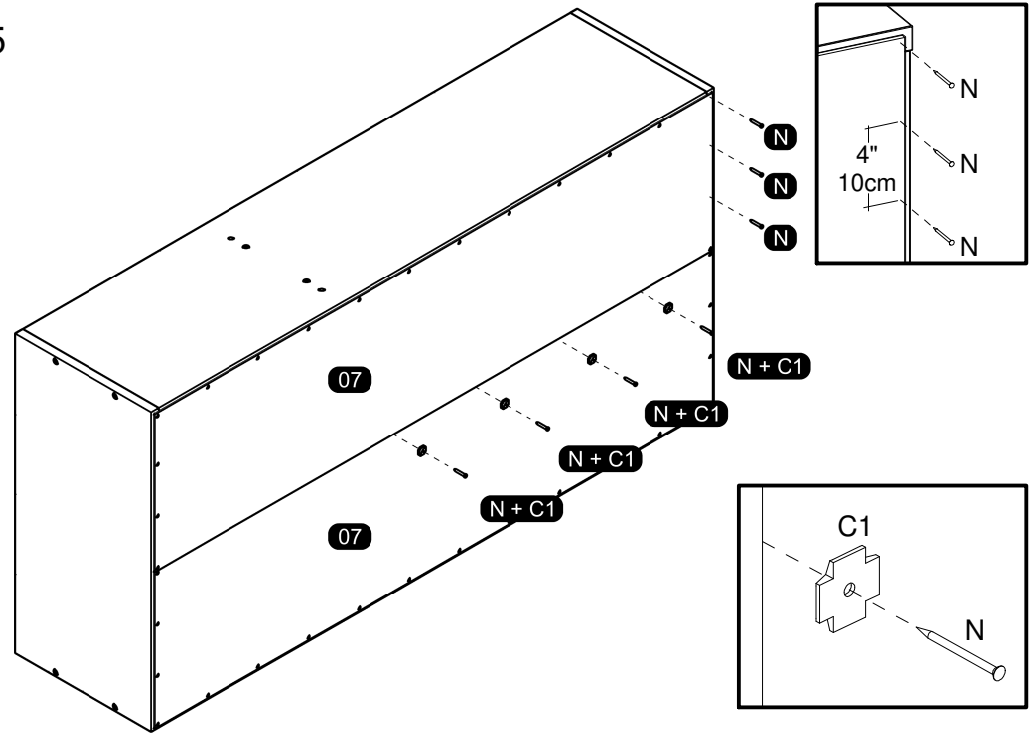

04

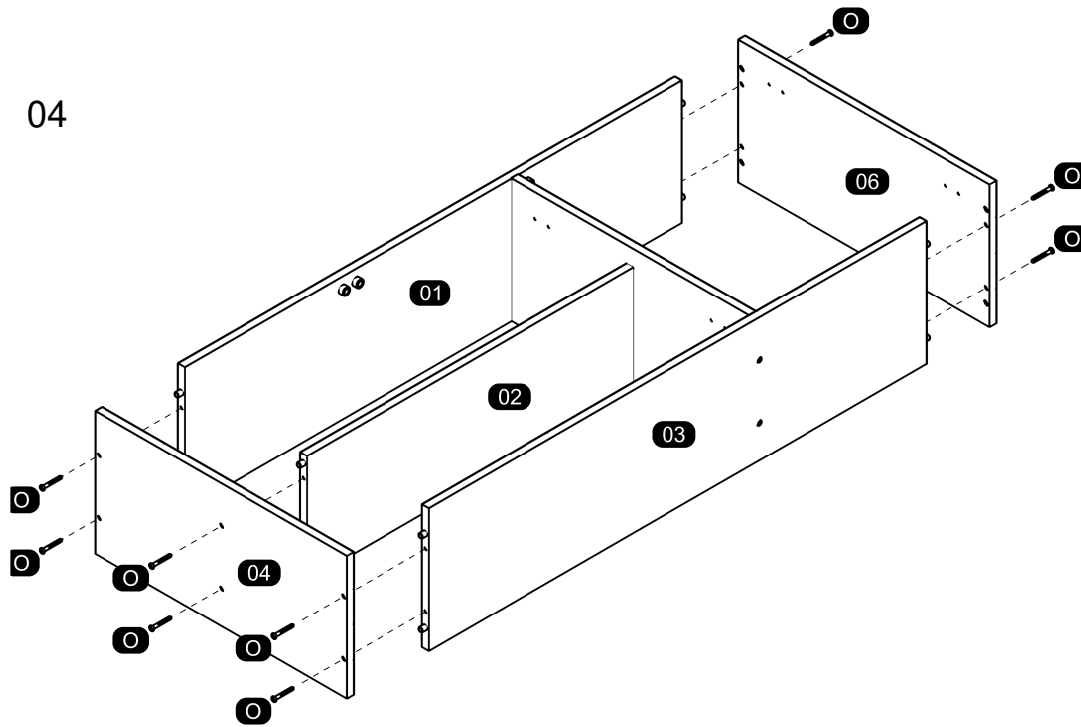

06

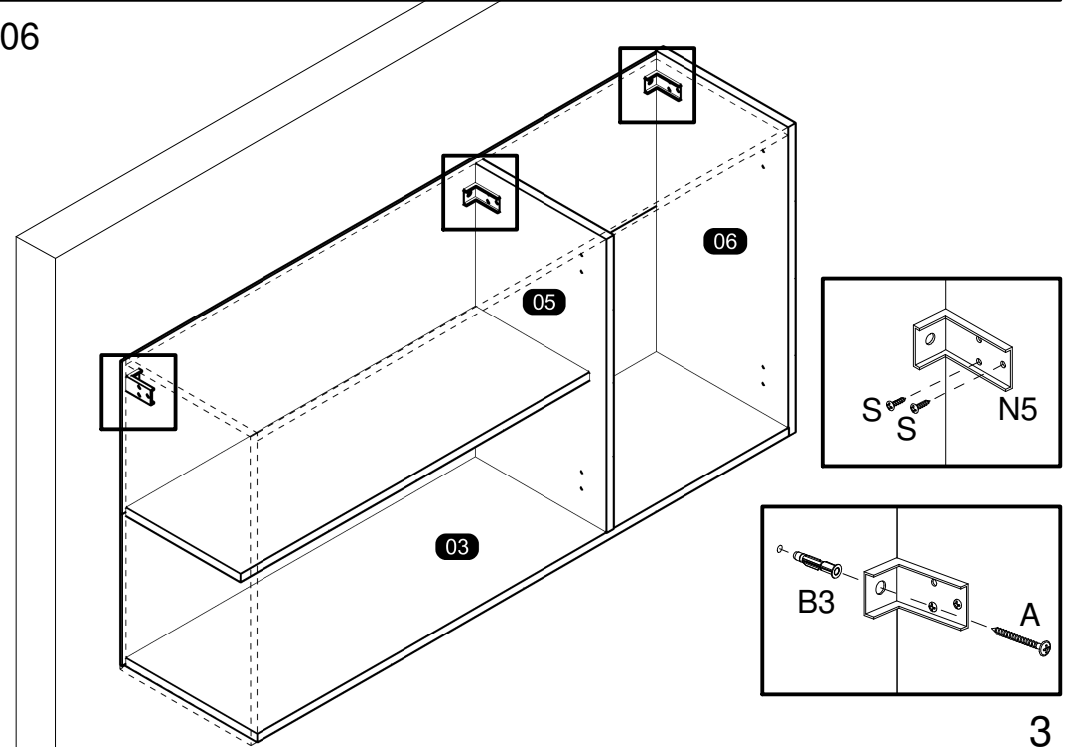

MOUNTING ON THE CHOSEN DOOR MODEL
 MONTAGEM NO MODELO DE PORTA ESCOLHIDO / MONTAJE EN EL MODELO DE PUERTA ELEGIDO

07

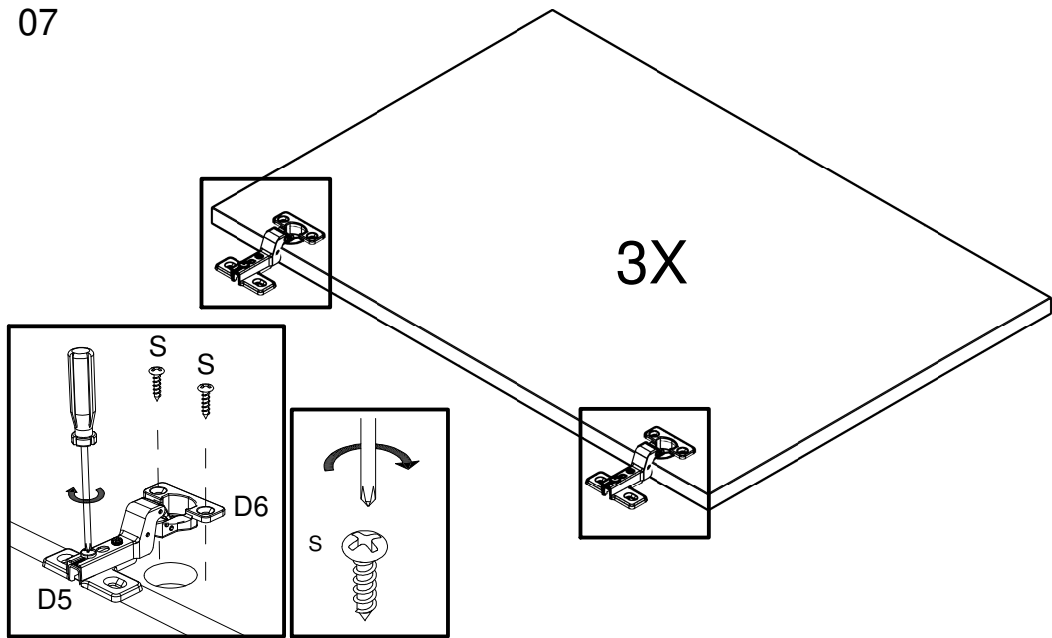

08

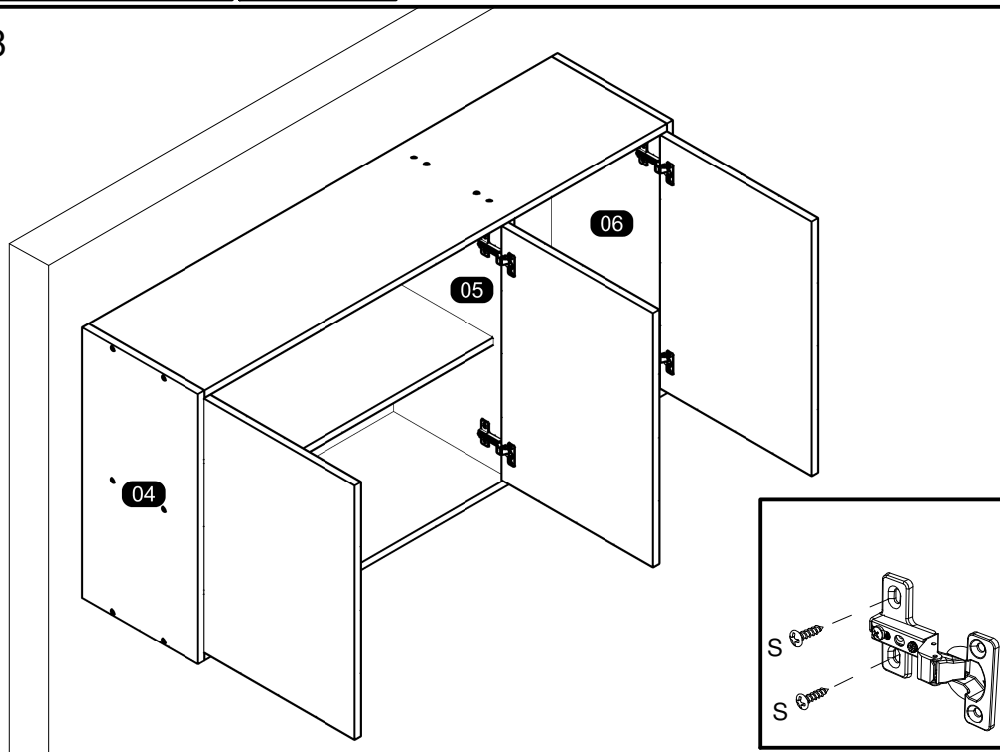

09

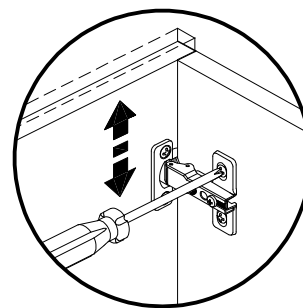
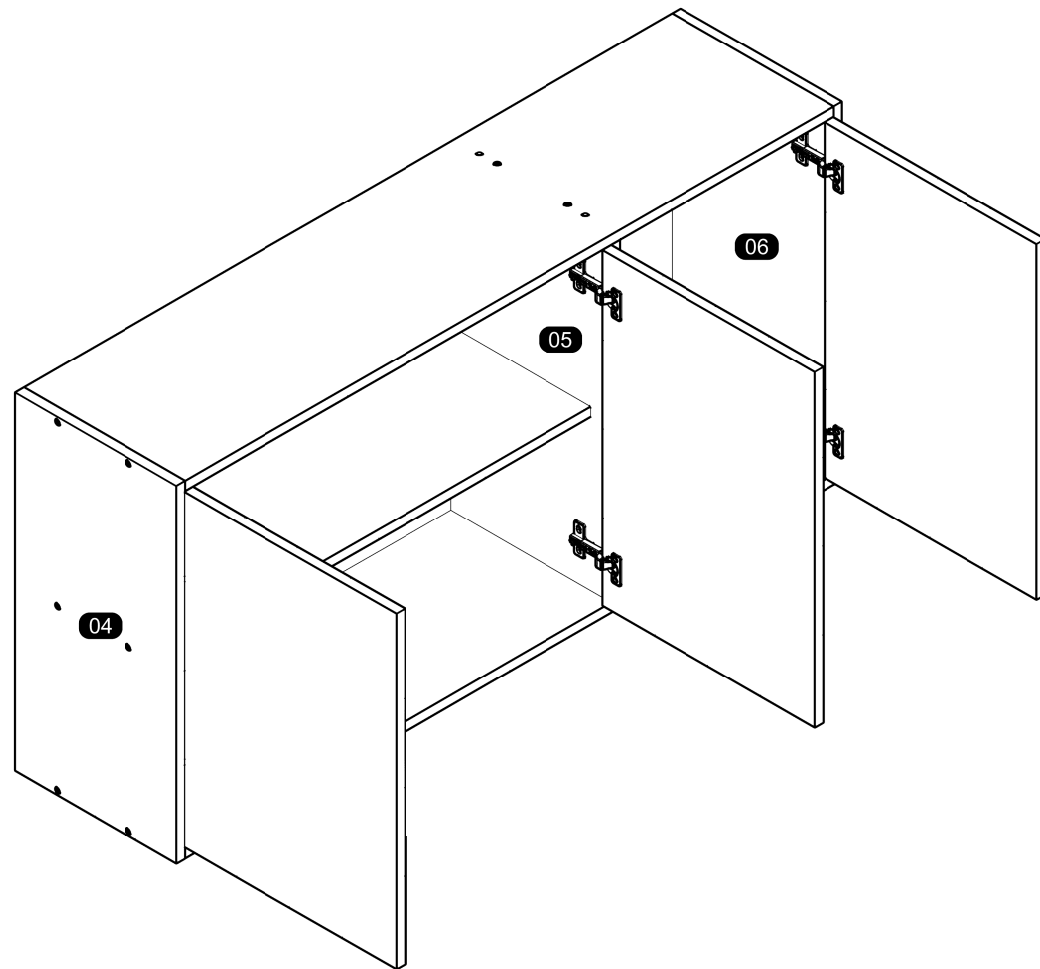

Vertical Adjustment
 Regulagem Vertical
 Ajuste Vertical

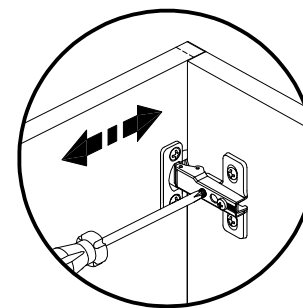

Horizontal Adjustment
 Regulagem Horizontal
 Ajuste Horizontal

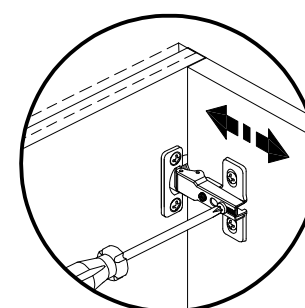

Depth Adjustment
 Regulagem Profundidade
 Ajuste Profundidad

ASSEMBLY INSTRUCTIONS MANUAL DE MONTAGEM / INSTRUCCIONES DE ARMADO

| Revise
| Revisão
| Revisión

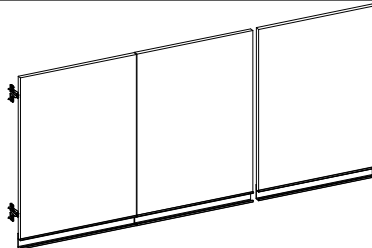

**YOU WILL NEED
VOCÊ VAI PRECISAR DE / USTED NECESITARÁ**

Tools not supplied
Ferramentas não fornecidas / Herramientas no incluidas

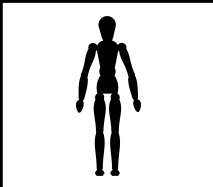

1 Person
1 Pessoa
1 Persona

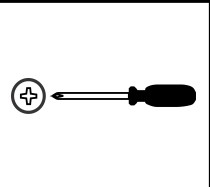

Screwdriver Phillips
Chave Phillips
Destornillador cruz

**PARTS IDENTIFICATION
IDENTIFICAÇÃO DAS PEÇAS / IDENTIFICACIÓN DE LAS PIEZAS**

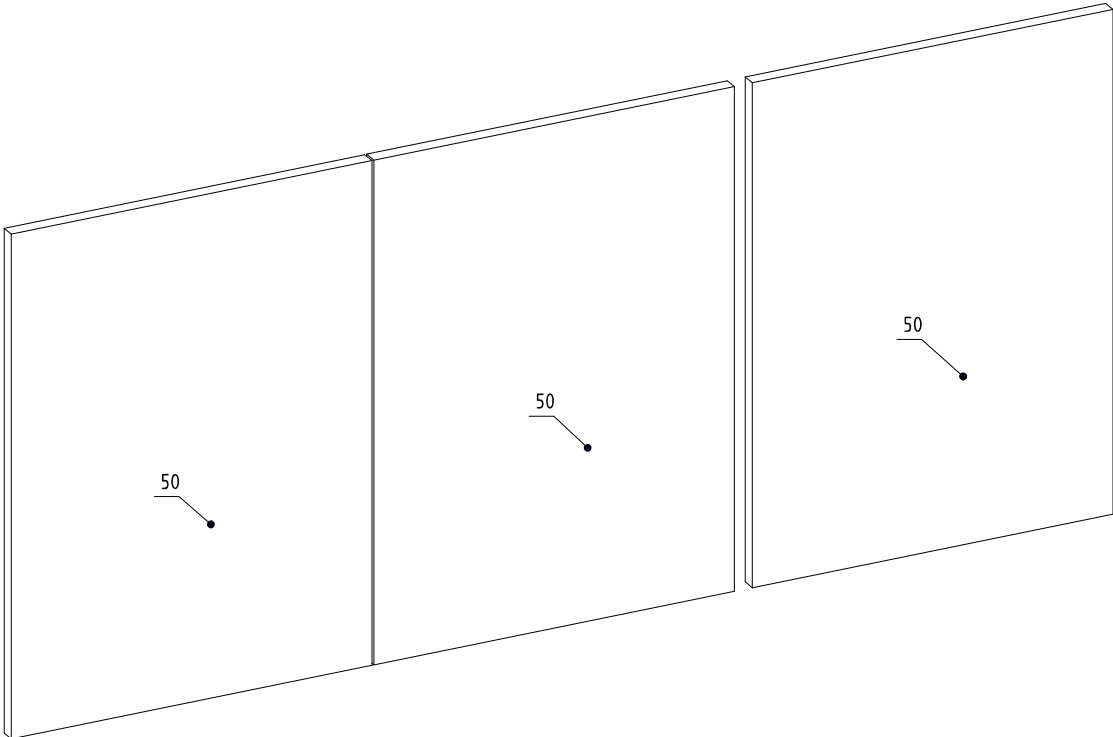

Nº	Measures_Inches	Medidas_cm	Qty./Qtd.
50	20 5/8 x 15 x 5/8	52.3 x 38.1 x 1.5	3

MAXIMUM RECOMMENDED WEIGHT BEING THIS EVENLY DISTRIBUTED.
PESO MÁXIMO RECOMENDADO SENDO ESTE DISTRIBUÍDO UNIFORMEMENTE.
PESO MÁXIMO RECOMENDADO SIENDO ESTE UNIFORMEMENTE DISTRIBUIDO.

—	LB	KG
---	----	----

IDENTIFICATION OF ACCESSORIES IDENTIFICAÇÃO DOS ACESSÓRIOS/ IDENTIFICACIÓN DE ACCESORIOS



The separation of the accessories before you start the assembly will facilitate the same. In case of doubt on the size of the screws and bolts, use the ruler at the bottom of the page.
 A separação dos acessórios antes de iniciar a montagem facilitará a mesma. Em caso de dúvida no tamanho dos parafusos e cavilhas, utilize a régua ao final da página.
 La separación de los accesorios antes de comenzar el armado facilitará el mismo. En caso de duda sobre el tamaño de los tornillos y taquetes, utilice la regla al pie de página.

K23		Handle Puxador Gola / Tirador	381 mm	3
o5		Flanged head screw Parafuso flangeado / Tornillo de cabeza flangeada	3,5x14 mm	9



ASSEMBLY MONTAGEM / ARMADO

02

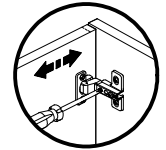
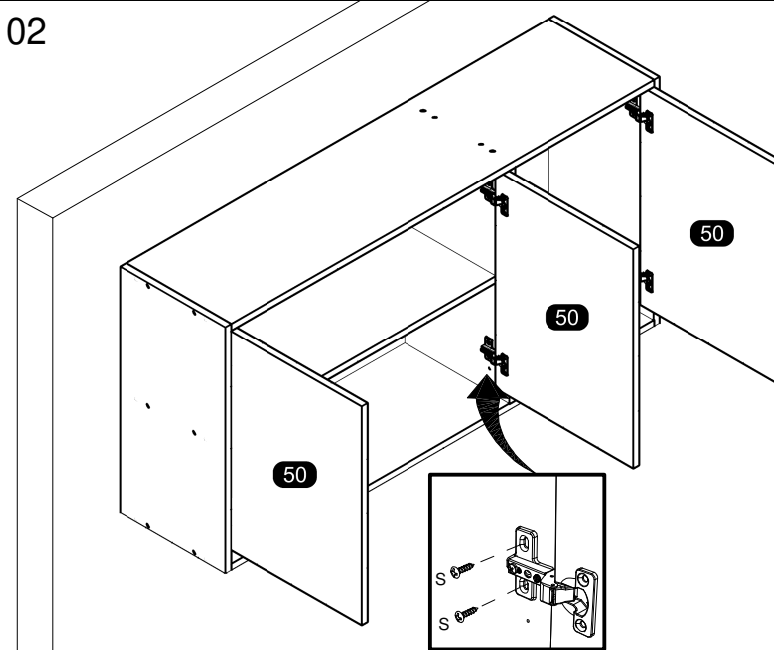

Horizontal Adjustment
Regulagem Horizontal
Ajuste Horizontal

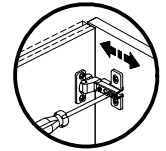

Depth Adjustment
Regulagem Profundidade
Ajuste Profundidad

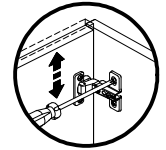

Vertical Adjustment
Regulagem Vertical
Ajuste Vertical

PRE-ASSEMBLY PRÉ-MONTAGEM / PRE ARMADO

01

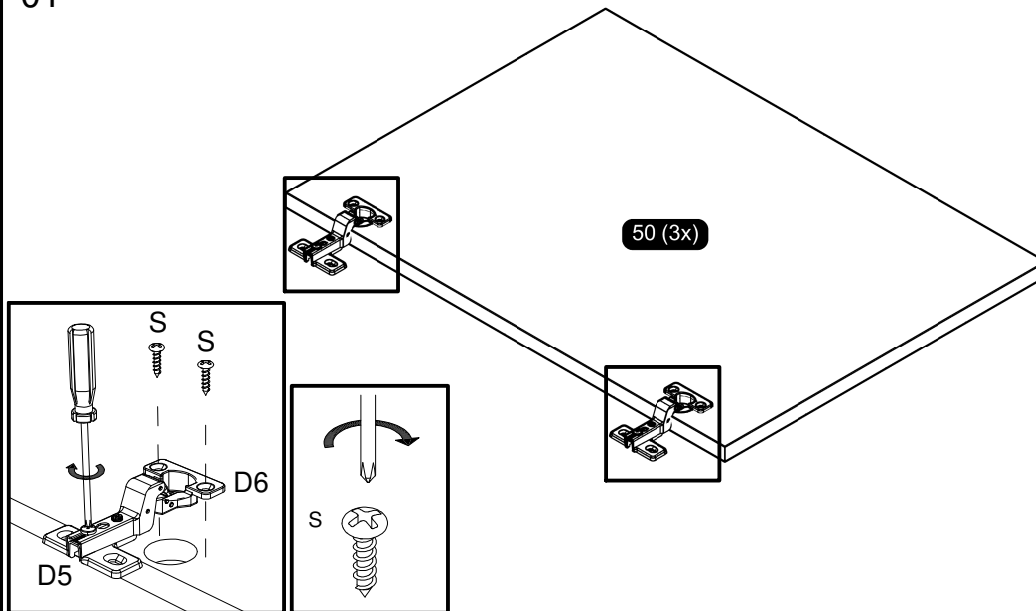

03

