

MANUAL DE MONTAGEM / ASSEMBLY INSTRUCTIONS / PLANO DE ARMADO

Antes de montar o móvel, leia com atenção o manual de montagem!
Before assembling the furniture, carefully read the assembly instructions!
Antes de armar el mueble, lea con atención el manual de ensamble!

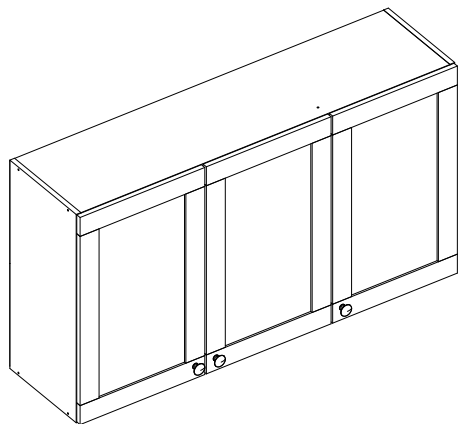

Ref.: 1355

genialflex
ambientes incríveis para todos

Parabéns! Você comprou um produto de excelente qualidade, fabricado com chapa de madeira de MDP ou MDF, extraída de florestas renováveis. Possui alta resistência e design atual.

Congratulations! You have purchased a product of excellent quality, made from MDP or MDF wood veneer, extracted from renewable forests. It has high strength and current design.

Felicitaciones! Usted compró a un producto de excelente calidad, fabricado con placa de madera de MDP o MDF, proveniente de florestas renovables. Tiene alta resistencia y diseño actual.



ATENÇÃO
ATTENTION
ATENCIÓN

- 1)** Verifique todas as peças antes de começar a montagem.
Check all parts before starting assembly.
Verifique todas las partes antes de empezar el armado.
- 2)** Ao começar a montagem, não apoie as peças na parede.
When starting the assembly, do not support the parts on the wall.
Al empezar el armado, no apoyes las partes en la pared.
- 3)** Ao colocar as peças e ferragens de lado, cuidado para não perde-las.
When placing parts and hardware aside, be careful not to lose them.
Al poner las piezas y herrages a parte, cuidado para no dañarlas.
- 4)** O móvel deve ser montado no chão, para isso, use a própria caixa para proteger e não danificar o piso.
The furniture must be mounted on the floor, to do this, use the box itself to protect and not damage the floor.
El mueble suele ser armando al piso, para eso, use la propia caja para protegerlo y no dañar al piso.
- 5)** Comece a montagem seguindo as instruções passo a passo.
Begin assembly by following the step-by-step instructions.
Comience el armado siguiendo la instrucciones paso a paso.
- 6)** É de responsabilidade do montador seguir as intruções desse manual, que são fundamentais para a estrutura do móvel.
It's the assembler's responsibility to follow the instructions in this manual, which are fundamental to the structure of the furniture.
Es de responsabilidad del armador seguir las instrucciones de este manual, que son fundamentales para la estructura del mueble.

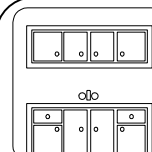

CUIDADOS
CARE
CUIDADO

- 1)** A conservação e limpeza deve ser feita com um pano levemente umedecido com água.
Care and cleaning should be done with a cloth slightly moistened with water.
La conservación y limpieza debe ser hecha con un trapo levemente humedecido en agua.
- 2)** Não use produtos abrasivos, como saponáceo, detergentes e esponja de aço.
Do not use abrasive products, such as soap, detergents and steel sponge.
No use productos abrasivos, como saponáceo, detergentes y esponja de acero.
- 3)** Não use cera ou óleo para dar brilho ao móvel.
Do not use wax or oil to shine the furniture.
No use cera o aceites para darle brillo al mueble.
- 4)** Não expor o móvel a interpéries e nem ao calor excessivo.
Do not expose the furniture to weather or excessive heat.
No exponer el mueble a interperies ni al calor excesivo.
- 5)** Ao terminar a montagem, limpe o ambiente e o móvel.
When the assembly is finished, clean the room and the furniture.
Al terminar el armado, limpie al ambiente y al mueble.

FERRAMENTAS / TOOLS / HERRAMIENTAS



MARTELO
HAMMER
MARTILLO



CHAVE PHILLIPS
PHILLIPS SCREWDRIVER
LLAVE PHILLIPS



NAO RECOMENDAVEL
NOT ADVISABLE
NO RECOMENDABLE



MARTELO DE BORRACHA
RUBBER HAMMER
MARTILLO GOMA









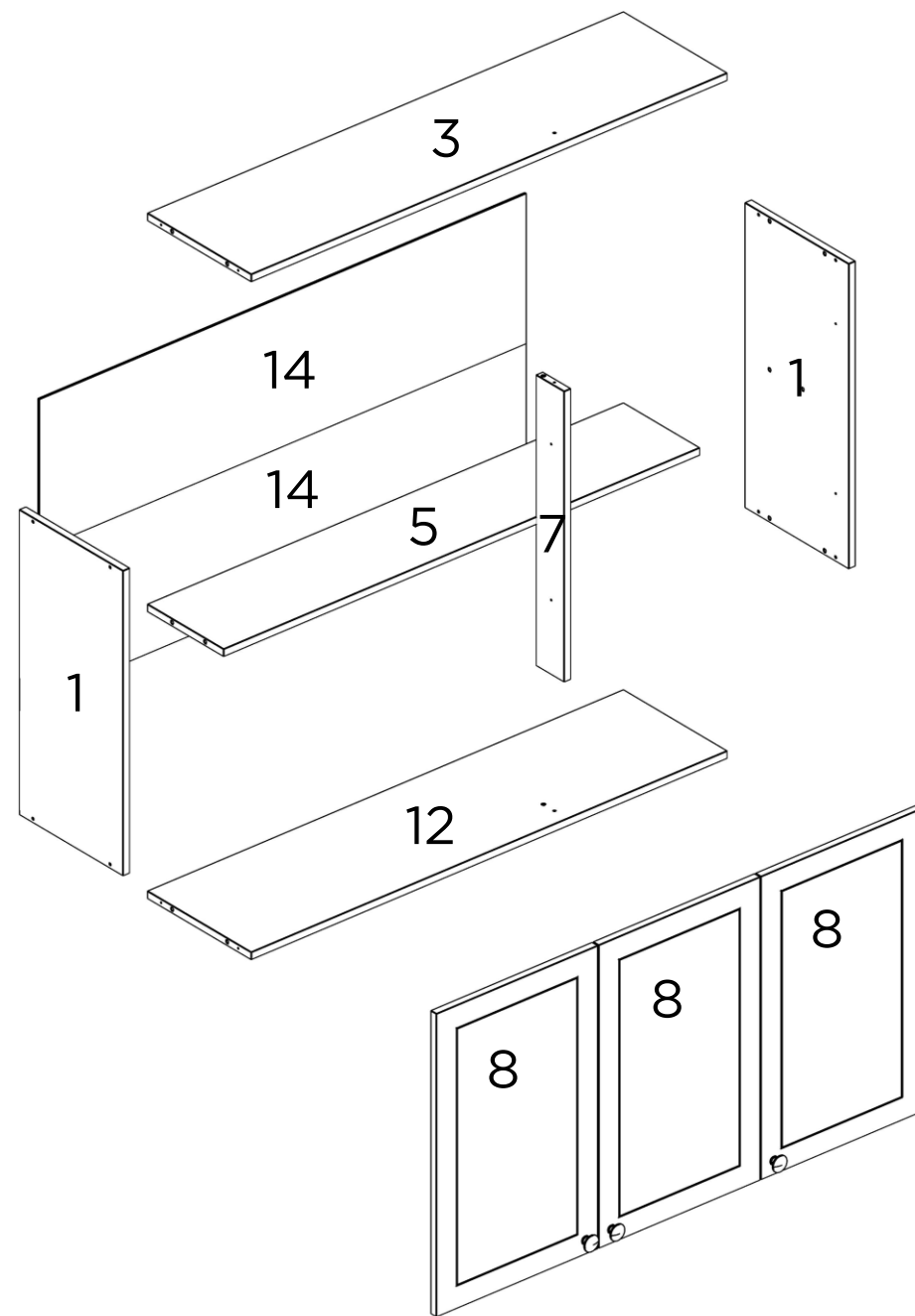

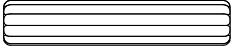

TRENA
MEASURING TAP
CINTA MÉTRICA

PEÇAS / PARTS / PIEZAS

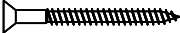
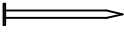
Nº No Num	DESCRIÇÃO DESCRIPTION DESCRIPCIÓN	QTD QTY CANT
1	LATERAL ESQUERDA LEFT SIDE LATERAL IZQUIERDA	2
3	TAMPO TOP TABLERO	1
5	PRATELEIRA SHELF PLATE REPISA	1
7	PILASTRA PILLAR PILAR	1
8	PORTA DOOR PUERTA	3
12	BASE BOTTOM BASE	1
14	COSTA BACK PANEL TRASERO	2

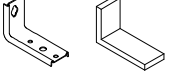

FERRAGENS / HARDWARE / HERRAJES

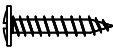
CÓD CODE COD	DESCRIÇÃO DESCRIPTION DESCRIPCIÓN	QTD QTY CANT
A	 CAVILHA WOODEN DOWEL TARUGO	14
B	 PARAFUSO 4X14mm SCREW 4X14mm TORNILLO 4X14mm	34
C	 DOBRADIÇA HINGE BIZAGRA	6
D	 CALÇO PARA DOBRADIÇA HINGE SHED CALZO DE BISAGRA	6
E	 PUXADOR HANDLE TIRADOR	3
F	 PARAFUSO 3,5X40mm SCREW 3,5X40mm TORNILLO 3,5X40mm	10
G	 PREGO NAIL CLAVO	50
H	 GARRA METÁLICA METALLIC CLAW GRAB METALICA	5
I	 SUPORTE DE FIXAÇÃO MOUNTING SUPPORT SOPORTE DE MONTAJE	2
J	 PARAFUSO 5X50mm SCREW 5X50mm TORNILLO 5X50mm	2
K	 BUCHA PLÁSTICA PLASTIC BUSHING CASQUILLO PLÁSTICO	2
L	 PARAFUSO 3,5X25mm SCREW 3,5X25mm TORNILLO 3,5X25mm	2
M	 PARAFUSO 3,5X25mm SCREW 3,5X25mm TORNILLO 3,5X25mm	6

UTILIZE A RÉGUA PARA IDENTIFICAR OS PARAFUSOS
UTILICE LA REGLA PARA IDENTIFICAR LOS TORNILLOS

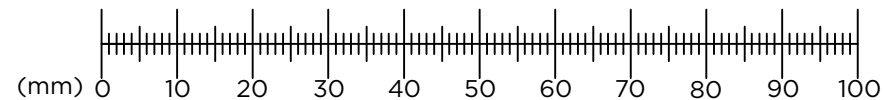

PESO SUPORTADO / PESO SOPORTADO

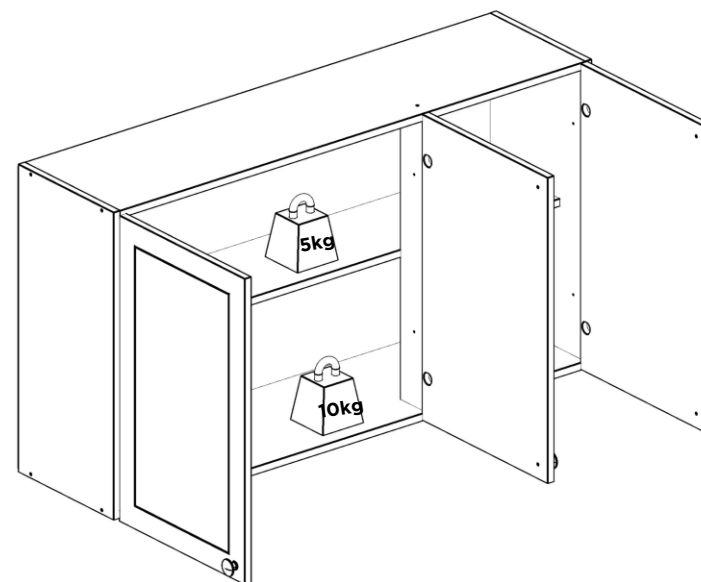

7

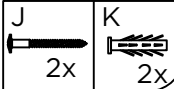
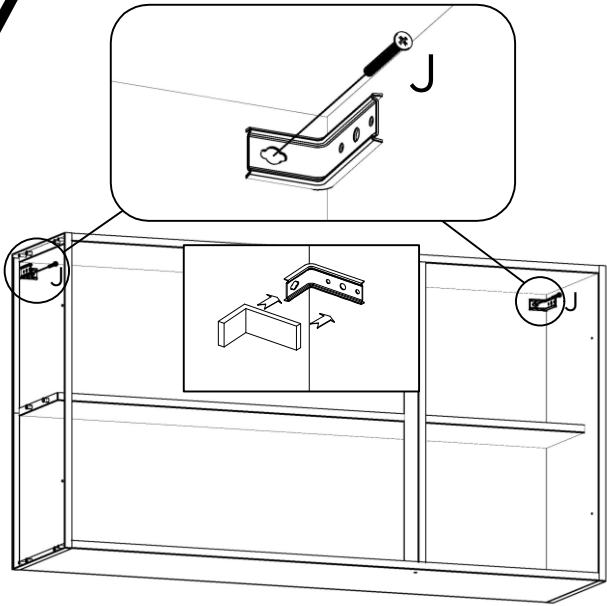

8

União de módulos.
Joining modules.
Unir módulos.

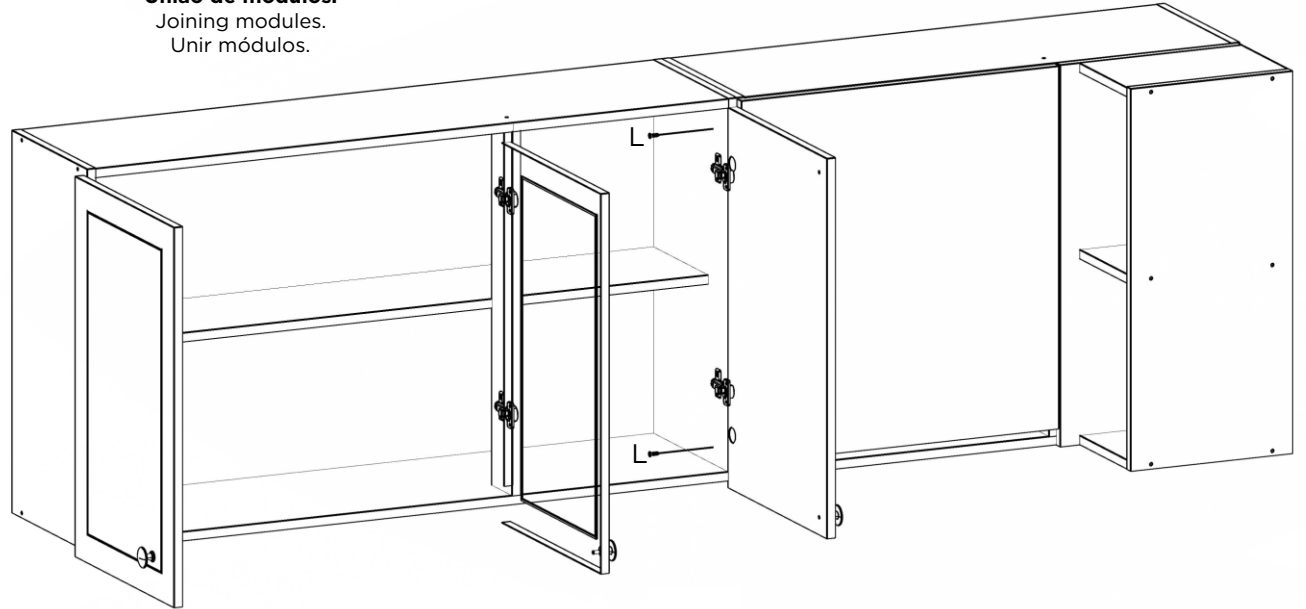

10

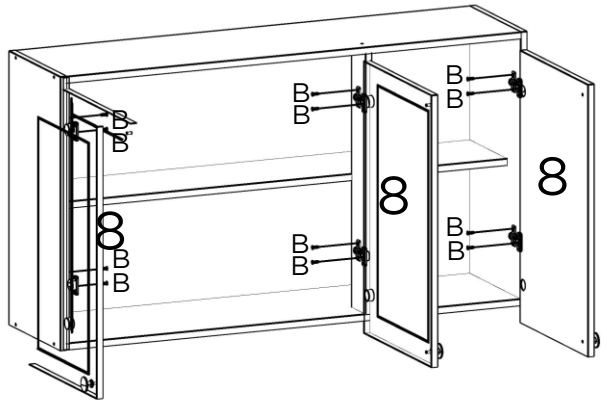

P



Parafuso 3,5x25mm

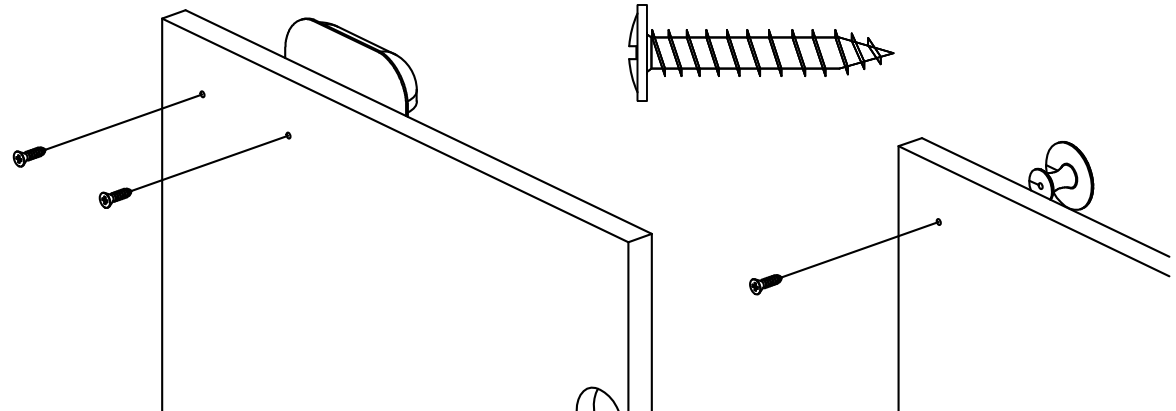

MANUAL DE MONTAGEM / ASSEMBLY INSTRUCTIONS / PLANO DE ARMADO

Antes de montar o móvel, leia com atenção o manual de montagem!
Before assembling the furniture, carefully read the assembly instructions!
Antes de armar el mueble, lea con atención el manual de ensamble!

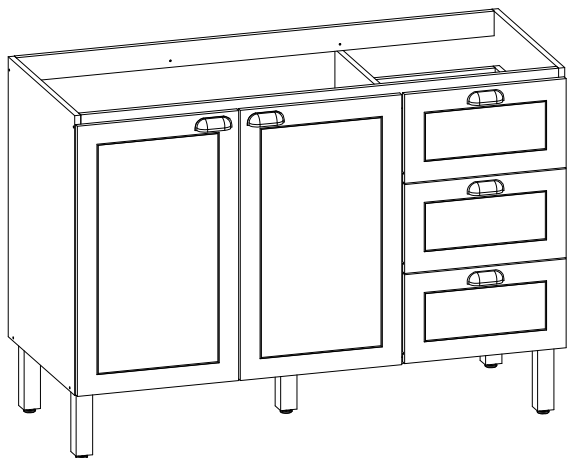

Ref.: 1353

geniaflex
ambientes incríveis para todos

Parabéns! Você comprou um produto de excelente qualidade, fabricado com chapa de madeira de MDP ou MDF, extraída de florestas renováveis. Possui alta resistência e design atual.

Congratulations! You have purchased a product of excellent quality, made from MDP or MDF wood veneer, extracted from renewable forests. It has high strength and current design.

Felicitaciones! Usted compró a un producto de excelente calidad, fabricado con placa de madera de MDP o MDF, proveniente de florestas renovables. Tiene alta resistencia y diseño actual.



ATENÇÃO
ATTENTION
ATENCIÓN

1) Verifique todas as peças antes de começar a montagem.

Check all parts before starting assembly.

Verifique todas las partes antes de empezar el armado.

2) Ao começar a montagem, não apoie as peças na parede.

When starting the assembly, do not support the parts on the wall.

Al empezar el armado, no apoyes las partes en la pared.

3) Ao colocar as peças e ferragens de lado, cuidado para não perde-las.

When placing parts and hardware aside, be careful not to lose them.

Al poner las piezas y herrages a parte, cuidado para no dañarlas.

4) O móvel deve ser montado no chão, para isso, use a própria caixa para proteger e não danificar o piso.

The furniture must be mounted on the floor, to do this, use the box itself to protect and not damage the floor.

El mueble suele ser armado al piso, para eso, use la propia caja para protegerlo y no dañar al piso.

5) Comece a montagem seguindo as instruções passo a passo.

Begin assembly by following the step-by-step instructions.

Comience el armado siguiendo la instrucciones paso a paso.

6) É de responsabilidade do montador seguir as intruções desse manual, que são fundamentais para a estrutura do móvel.

It's the assembler's responsibility to follow the instructions in this manual, which are fundamental to the structure of the furniture.

Es de responsabilidad del armador seguir las instrucciones de este manual, que son fundamentales para la estructura del mueble.

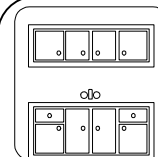

CUIDADOS
CARE
CUIDADO

1) A conservação e limpeza deve ser feita com um pano levemente umedecido com água.

Care and cleaning should be done with a cloth slightly moistened with water.

La conservación y limpieza debe ser hecha con un trapo levemente humedecido en agua.

2) Não use produtos abrasivos, como saponáceo, detergentes e esponja de aço.

Do not use abrasive products, such as soap, detergents and steel sponge.

No use productos abrasivos, como saponáceo, detergentes y esponja de acero.

3) Não use cera ou óleo para dar brilho ao móvel.

Do not use wax or oil to shine the furniture.

No use cera o aceites para darle brillo al mueble.

4) Não expor o móvel a interpéries e nem ao calor excessivo.

Do not expose the furniture to weather or excessive heat.

No exponer el mueble a interperies ni al calor excesivo.

5) Ao terminar a montagem, limpe o ambiente e o móvel.

When the assembly is finished, clean the room and the furniture.

Al terminar el armado, limpie al ambiente y al mueble.

FERRAMENTAS / TOOLS / HERRAMIENTAS



MARTELO
HAMMER
MARTILLO



CHAVE PHILLIPS
PHILLIPS SCREWDRIVER
LLAVE PHILLIPS



NAO RECOMENDAVEL
NOT ADVISABLE
NO RECOMENDABLE



MARTELO DE BORRACHA
RUBBER HAMMER
MARTILLO GOMA



TRENA
MEASURING TAP
CINTA MÉTRICA

PEÇAS / PARTS / PIEZAS

Nº No Num	DESCRIÇÃO DESCRIPTION DESCRIPCIÓN	QTD QTY CANT
1	LATERAL DIREITA RIGHT SIDE LATERAL DERECHA	1
2	LATERAL ESQUERDA LEFT SIDE LATERAL IZQUIERDA	1
3	PRATELEIRA SHELF ESTANTE	1
4	DIVISÃO DIVISION DIVISIÓN	1
5	TRAVESSA FRONTAL FRONT CROSS TRAVESAÑO FRONTAL	1
6	TRAVESSA TRASEIRA BACK CROSS TRAVESAÑO TRASERO	1
7	PILASTRA PILASTER PILASTRA	1
8	PORTA PERFIL PROFILE DOOR PUERTA	2
10	FRENTE DE GAVETA DRAWER FRONT FRENTE DEL CAJÓN	3
11	LATERAL DE GAVETA DRAWER SIDE LATERAL DEL CAJÓN	6
12	COSTA DE GAVETA DRAWER BACK TRASERO DEL CAJÓN	3
13	BASE LOWER TOP TAPA INFERIOR	1
14	COSTA BACK PANEL DORSO TRASERO	2
15	FUNDO DE GAVETA DRAWER BOTTOM FONDO DEL CAJÓN	3

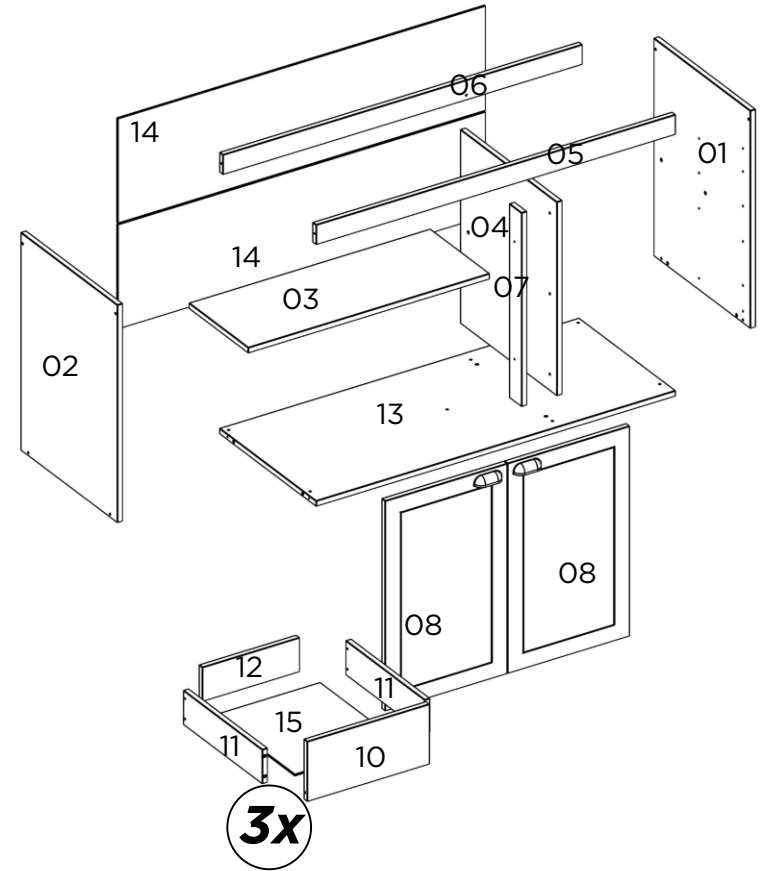

FERRAGENS / HARDWARE / HERRAJES

CÓD CODE COD	DESCRIÇÃO DESCRIPTION DESCRIPCIÓN	QTD QTY CANT
A	CAVILHA 8X30 WOODEN DOWEL 8X30 TARUGO 8X30	18
B	PARAFUSO 4X14mm SCREW 4X14mm TORNILLO 4X14mm	100
C	CORREDIÇA SLIDE CORREDERA	3
D	PARAFUSO 5X50mm SCREW 5X50mm TORNILLO 5X50mm	5
E	PÉ LEG PATA	5
F	PARAFUSO 3,5X40mm SCREW 3,5X40mm TORNILLO 3,5X40mm	10
G	PARAFUSO 3,5X25mm SCREW 3,5X25mm TORNILLO 3,5X25mm	16
H	PREGO NAIL CLAVO	30
L	PREGO ANELADO RINGED NAIL CLAVO ANILLADO	42
N	SUPORTE PRATELEIRA SUPPORT SHELF SOPORTE DE REPISA	4
O	PERFIL H PROFILE H PERFIL H	4
Q	CALÇO PARA DOBRADIÇA HINGE SHED CALZO DE BISAGRA	4
R	DOBRADIÇA HINGE BIZAGRA	4
T	CANTONEIRA DE 2 FUROS METALLIC ANGLE CANTONERA 2 AGUJEROS	2
U	CANTONEIRA DE 4 FUROS METALLIC ANGLE CANTONERA 4 AGUJEROS	10
V	PUXADOR HANDLE TIRADOR	5

UTILIZE A RÉGUA PARA IDENTIFICAR OS PARAFUSOS
USE THE RULER TO IDENTIFY THE SCREWS
UTILICE LA REGLA PARA IDENTIFICAR LOS TORNILLOS

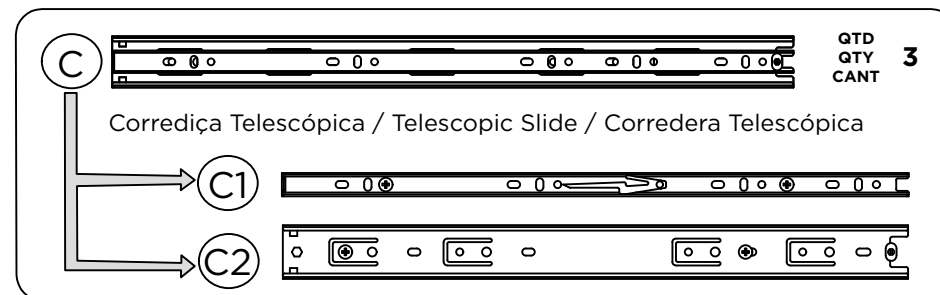

PESO SUPORTADO / WEIGHT SUPPORTED / PESO SOPORTADO

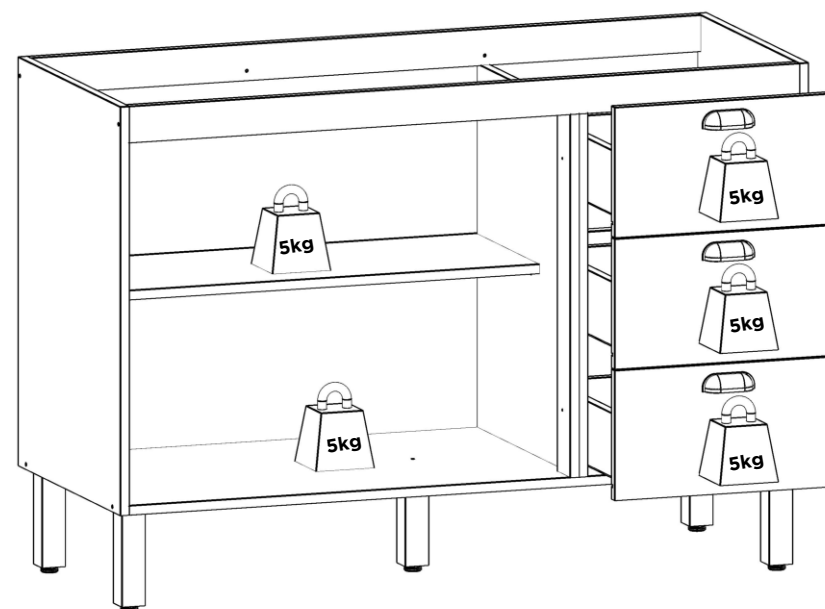

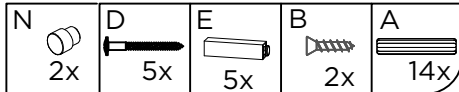
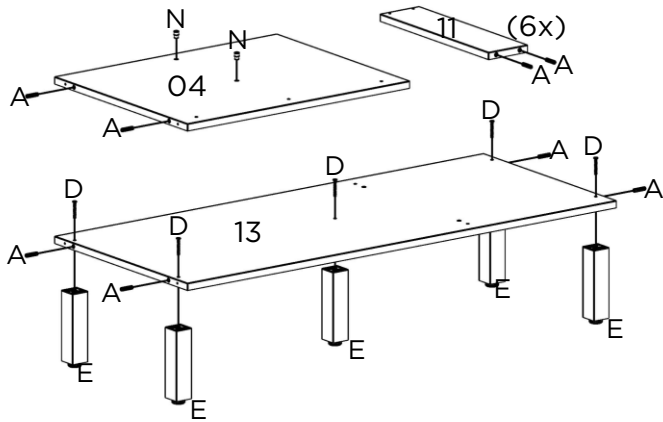
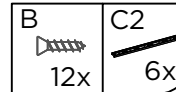
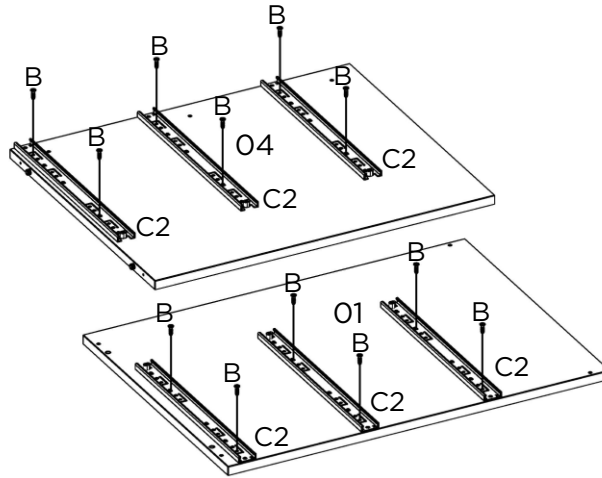
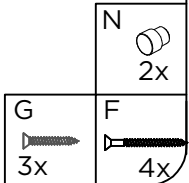
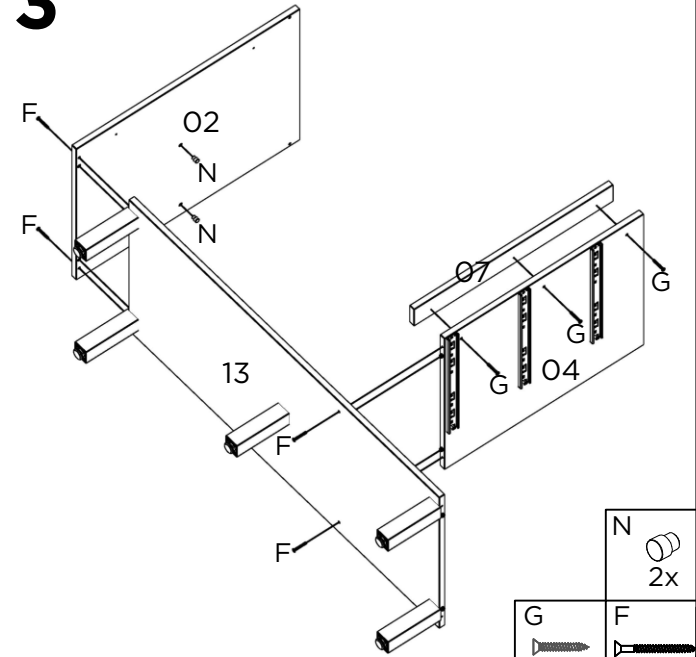
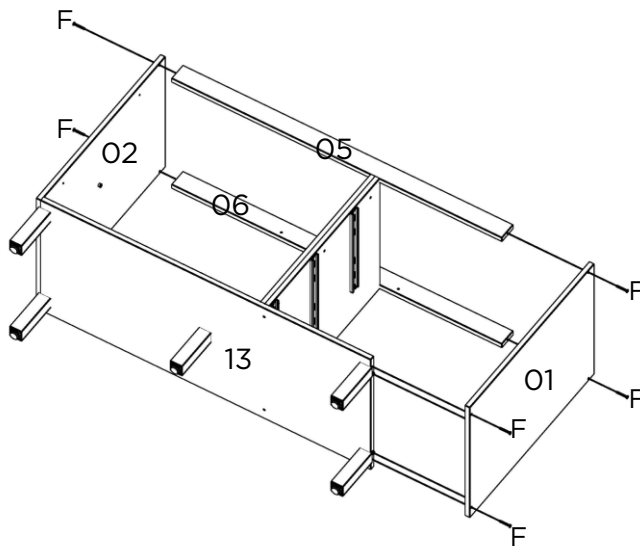
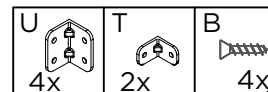
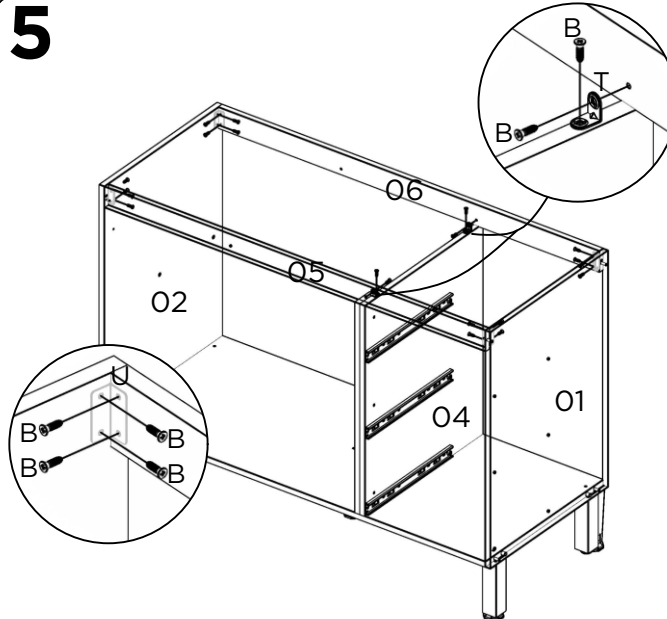
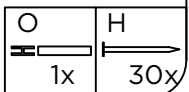
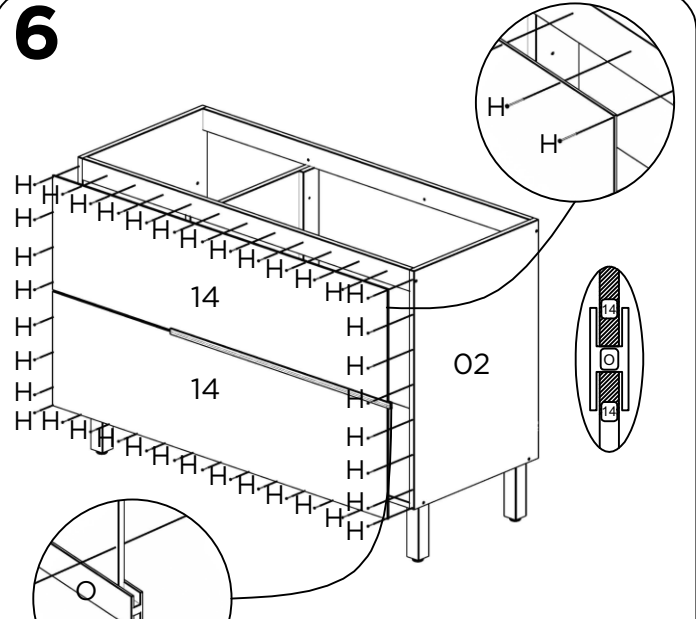
1**2****3****4****5****6**

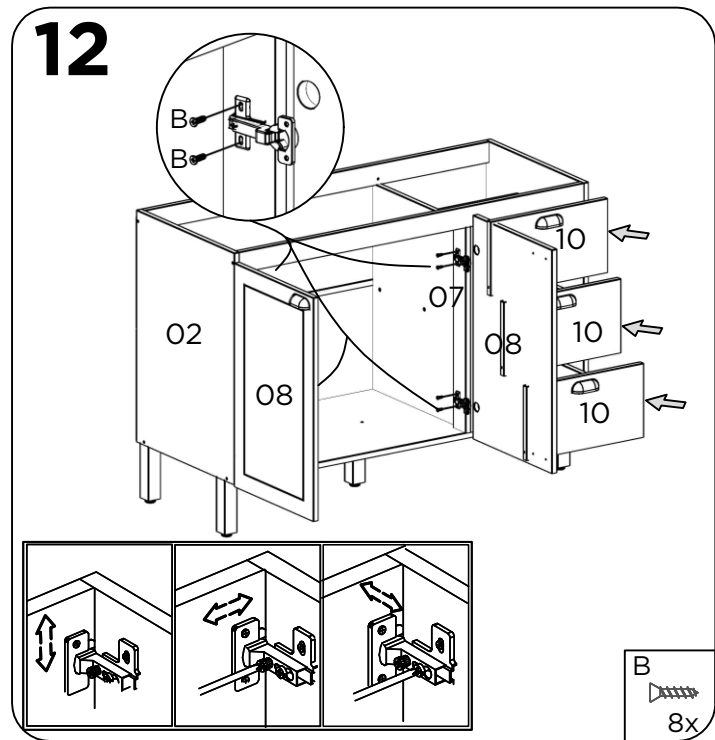
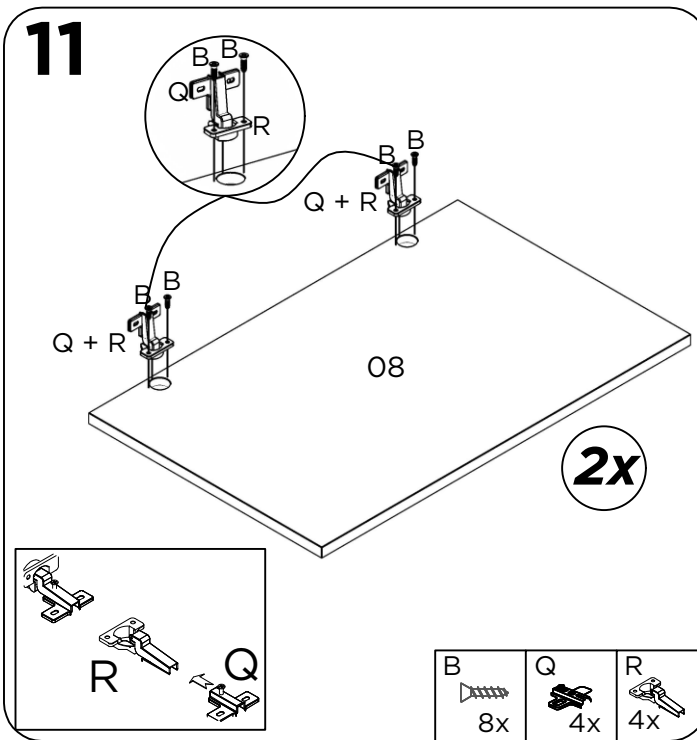
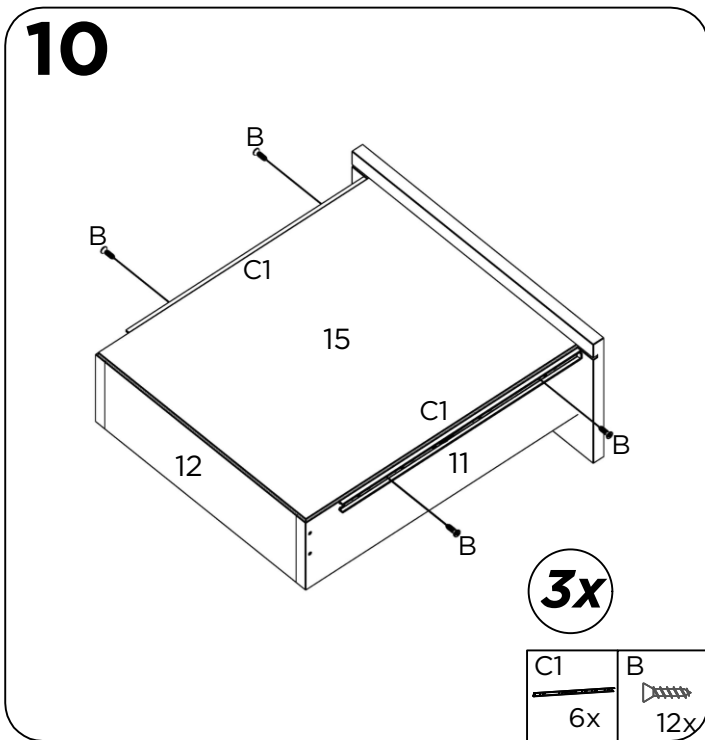
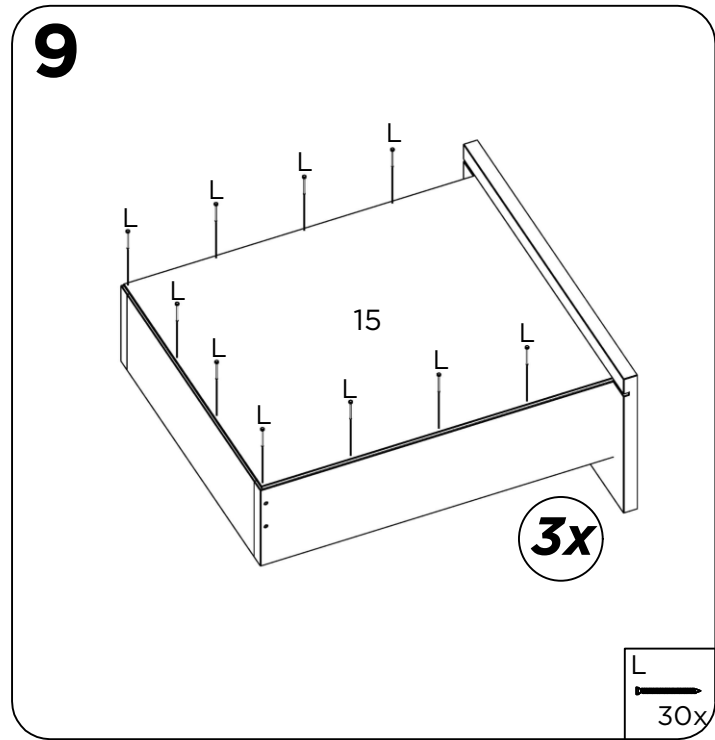
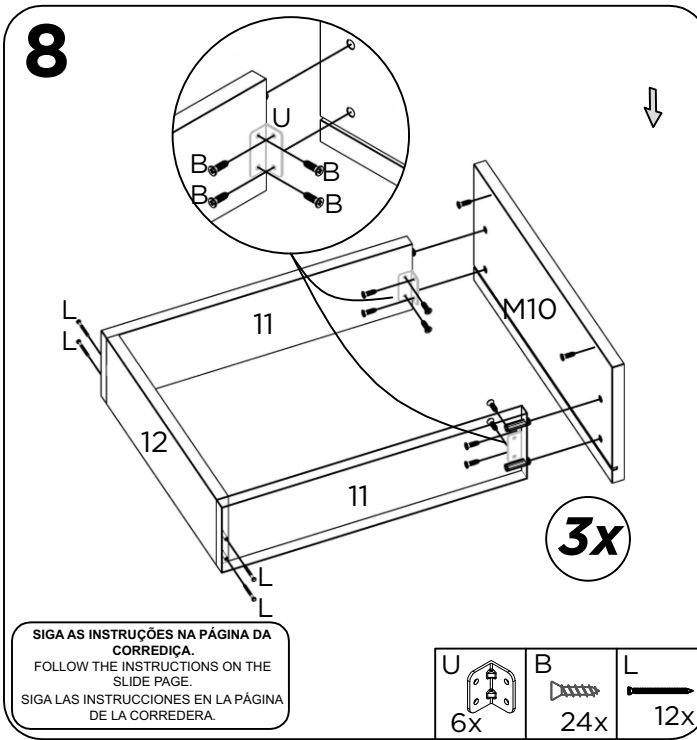
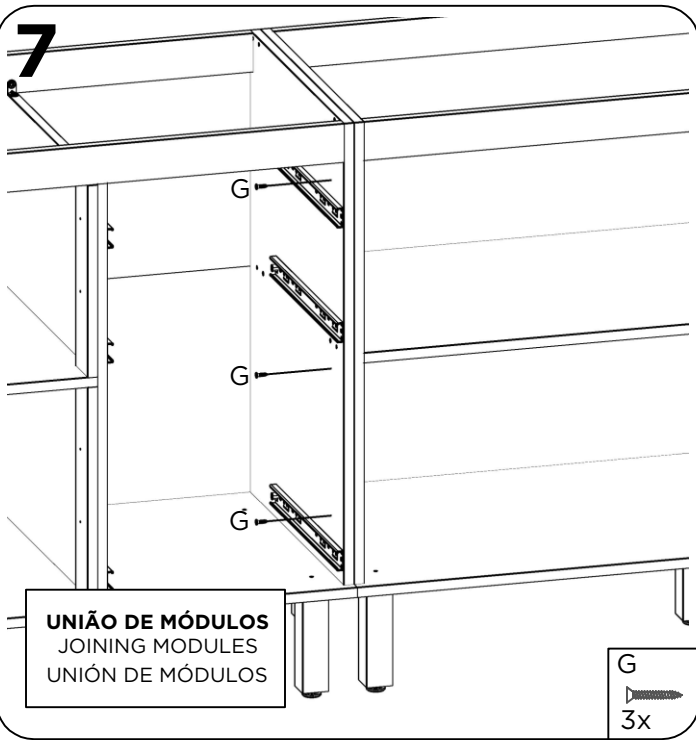

13

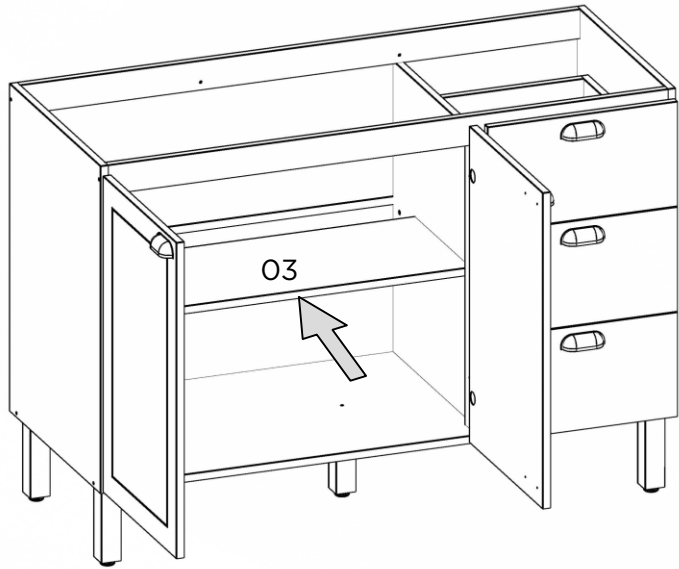

14

Intalação dos puxadores conforme modelo adquirido, siga os passos no manual dos puxadores.
Instalación de las manijas según el modelo adquirido, seguir los pasos del manual de manijas.

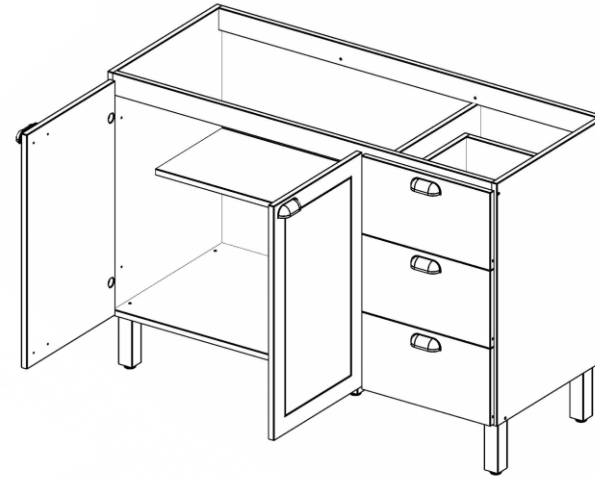

15

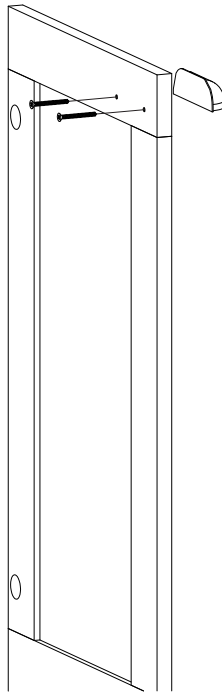

16

P

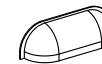

Parafuso 3,5x25mm

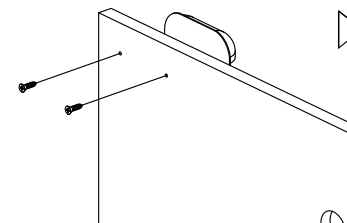

MANUAL DE MONTAGEM / ASSEMBLY INSTRUCTIONS / PLANO DE ARMADO

Antes de montar o móvel, leia com atenção o manual de montagem!
Before assembling the furniture, carefully read the assembly instructions!
Antes de armar el mueble, lea con atención el manual de ensamble!

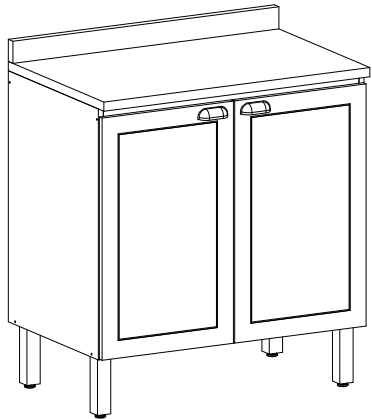

Ref.: 1354

genialflex
ambientes incríveis para todos

Parabéns! Você comprou um produto de excelente qualidade, fabricado com chapa de madeira de MDP ou MDF, extraída de florestas renováveis. Possui alta resistência e design atual.

Congratulations! You have purchased a product of excellent quality, made from MDP or MDF wood veneer, extracted from renewable forests. It has high strength and current design.

Felicitaciones! Usted compró a un producto de excelente calidad, fabricado con placa de madera de MDP o MDF, proveniente de florestas renovables. Tiene alta resistencia y diseño actual.



**ATENÇÃO
ATTENTION
ATENCIÓN**

1) Verifique todas as peças antes de começar a montagem.

Check all parts before starting assembly.

Verifique todas las partes antes de empezar el armado.

2) Ao começar a montagem, não apoie as peças na parede.

When starting the assembly, do not support the parts on the wall.

Al empezar el armado, no apoyes las partes en la pared.

3) Ao colocar as peças e ferragens de lado, cuidado para não perde-las.

When placing parts and hardware aside, be careful not to lose them.

Al poner las piezas y herrajes a parte, cuidado para no dañarlas.

4) O móvel deve ser montado no chão, para isso, use a própria caixa para proteger e não danificar o piso.

The furniture must be mounted on the floor, to do this, use the box itself to protect and not damage the floor.

El mueble suele ser armado al piso, para eso, use la propia caja para protegerlo y no dañar al piso.

5) Comece a montagem seguindo as instruções passo a passo.

Begin assembly by following the step-by-step instructions.

Comience el armado siguiendo la instrucciones paso a paso.

6) É de responsabilidade do montador seguir as intruções desse manual, que são fundamentais para a estrutura do móvel.

It's the assembler's responsibility to follow the instructions in this manual, which are fundamental to the structure of the furniture.

Es de responsabilidad del armador seguir las instrucciones de este manual, que son fundamentales para la estructura del mueble.

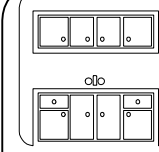

**CUIDADOS
CARE
CUIDADO**

1) A conservação e limpeza deve ser feita com um pano levemente umedecido com água.

Care and cleaning should be done with a cloth slightly moistened with water.

La conservación y limpieza debe ser hecha con un trapo levemente humedecido en agua.

2) Não use produtos abrasivos, como saponáceo, detergentes e esponja de aço.

Do not use abrasive products, such as soap, detergents and steel sponge.

No use productos abrasivos, como saponáceo, detergentes y esponja de acero.

3) Não use cera ou óleo para dar brilho ao móvel.

Do not use wax or oil to shine the furniture.

No use cera o aceites para darle brillo al mueble.

4) Não expor o móvel a interperies e nem ao calor excessivo.

Do not expose the furniture to weather or excessive heat.

No exponer el mueble a interperies ni al calor excesivo.

5) Ao terminar a montagem, limpe o ambiente e o móvel.

When the assembly is finished, clean the room and the furniture.

Al terminar el armado, limpie al ambiente y al mueble.

FERRAMENTAS / TOOLS / HERRAMIENTAS



MARTELO
HAMMER
MARTILLO



MARTELO DE BORRACHA
RUBBER HAMMER
MARTILLO GOMA



NAO RECOMENDAVEL
NOT ADVISABLE
NO RECOMENDABLE



CHAVE PHILLIPS
PHILLIPS SCREWDRIVER
LLAVE PHILLIPS









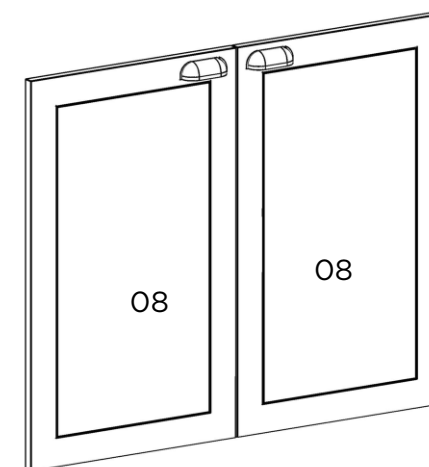
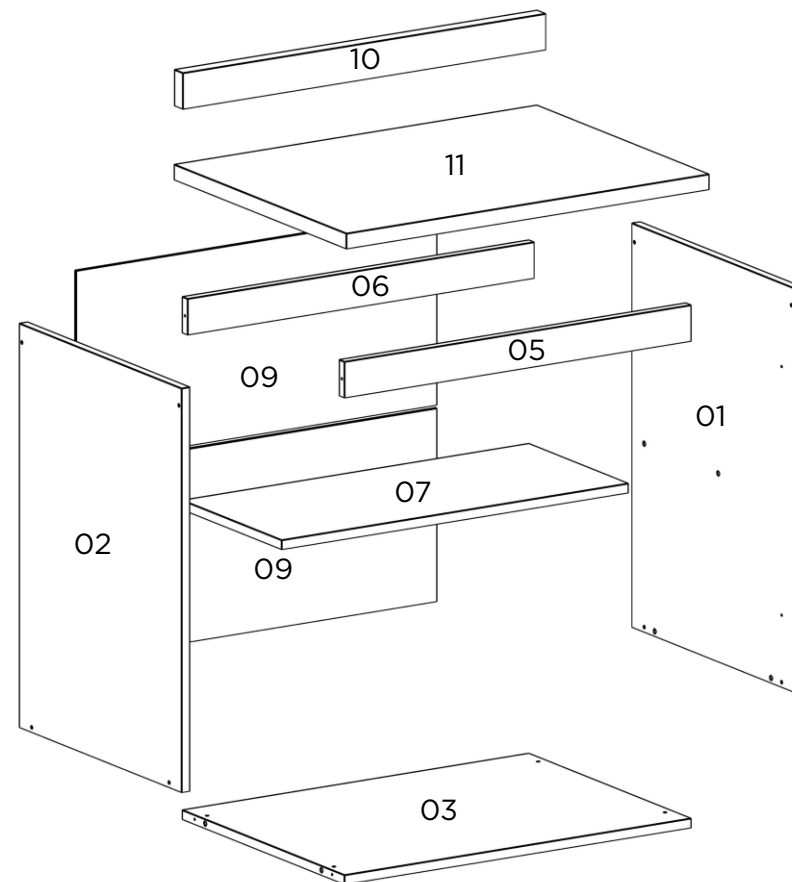

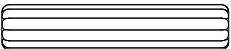
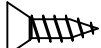

TRENA
MEASURING TAP
CINTA MÉTRICA

PEÇAS / PARTS / PIEZAS

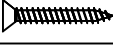
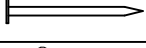
Nº No Num	DESCRIÇÃO DESCRIPTION DESCRIPCIÓN	QTD QTY CANT
1	LATERAL DIREITA RIGHT SIDE LATERAL DERECHA	1
2	LATERAL ESQUERDA LEFT SIDE LATERAL IZQUIERDA	1
3	BASE LOWER TOP TAPA INFERIOR	1
5	TRAVESSA FRONTAL FRONT CROSS TRAVESAÑO FRONTAL	1
6	TRAVESSA TRASEIRA BACK CROSS TRAVESAÑO TRASERO	1
7	PRATELEIRA SHELF ESTANTE	1
8	PORTA PERFIL PROFILE DOOR PUERTA	2
9	COSTA BACK PANEL DORSO	2
10	ESPELHO BACK CROSS TRAVESAÑO TRASERO	1
11	TAMPO SUPERIOR UPPER TOP TAPA SUPERIOR	1

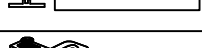

FERRAGENS / HARDWARE / HERRAJES

CÓD CODE COD	DESCRIÇÃO DESCRIPTION DESCRIPCIÓN	QTD QTY CANT
A	 CAVILHA 8X30 WOODEN DOWEL 8X30 TARUGO 8X30	4
B	 PARAFUSO 4X14mm SCREW 4X14mm TORNILLO 4X14mm	36
D	 PARAFUSO 5X50mm SCREW 5X50mm TORNILLO 5X50mm	4
E	 PÉ LEG PATA	4
F	 PARAFUSO 3,5X40mm SCREW 3,5X40mm TORNILLO 3,5X40mm	11
G	 PARAFUSO 3,5X25mm SCREW 3,5X25mm TORNILLO 3,5X25mm	6
H	 PREGO NAIL CLAVO	24
N	 SUPORTE PRATELEIRA SUPPORT SHELF SOPORTE DE REPISA	4
O	 PERFIL H PROFILE H PERFIL H	1
Q	 CALÇO PARA DOBRADIÇA HINGE SHED CALZO DE BISAGRA	4
R	 DOBRADIÇA HINGE BIZAGRA	4
T	 CANTONEIRA DE 2 FUROS METALLIC ANGLE CANTONERA 2 AGUJEROS	8
V	 PUXADOR HANDLE TIRADOR	2

UTILIZE A RÉGUA PARA IDENTIFICAR OS PARAFUSOS
USE THE RULER TO IDENTIFY THE SCREWS
UTILICE LA REGLA PARA IDENTIFICAR LOS TORNILLOS



PESO SUPORTADO / WEIGHT SUPPORTED / PESO SOPORTADO

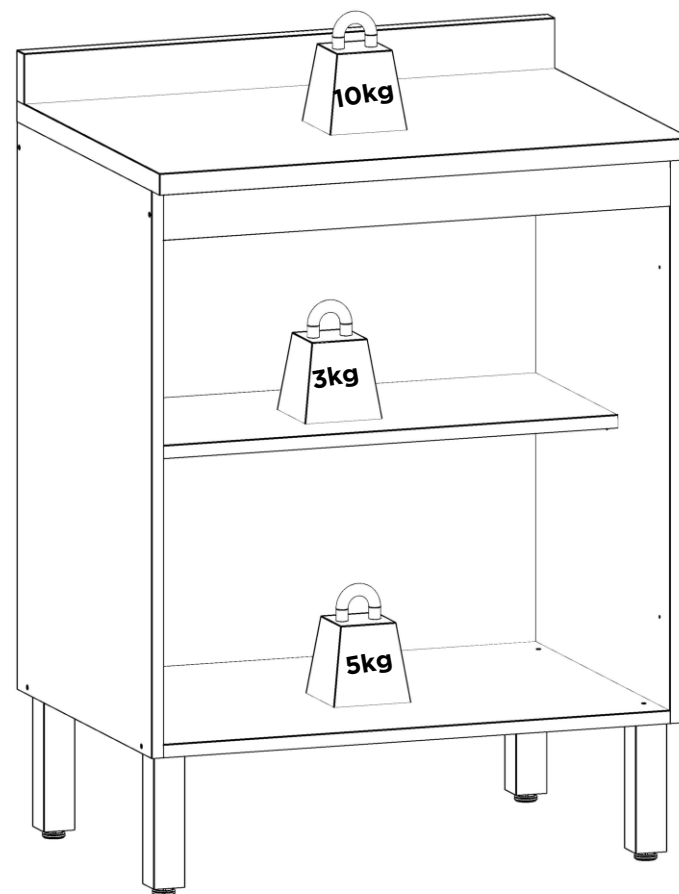

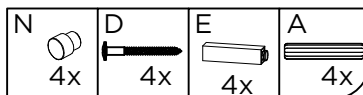
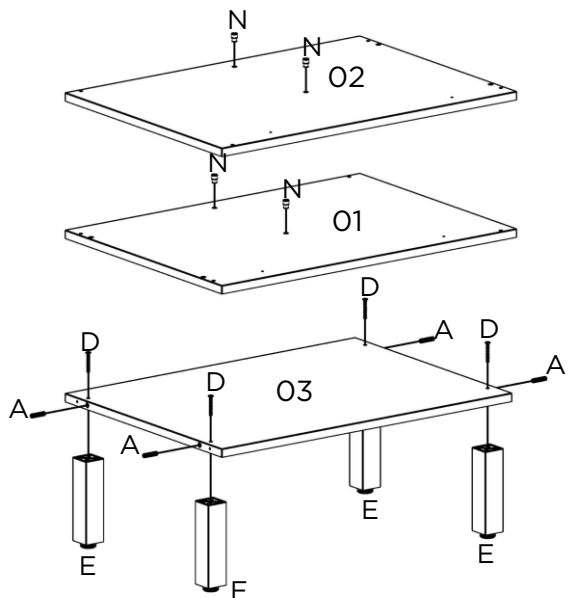
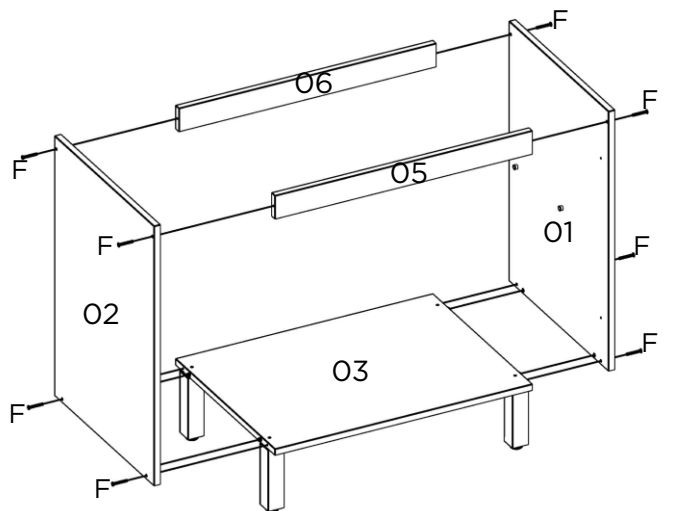
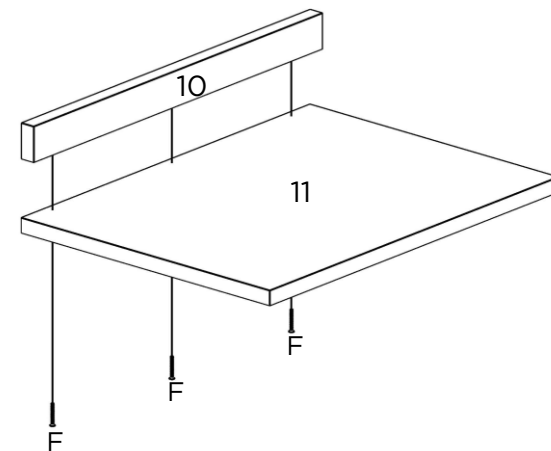
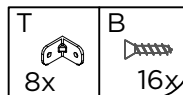
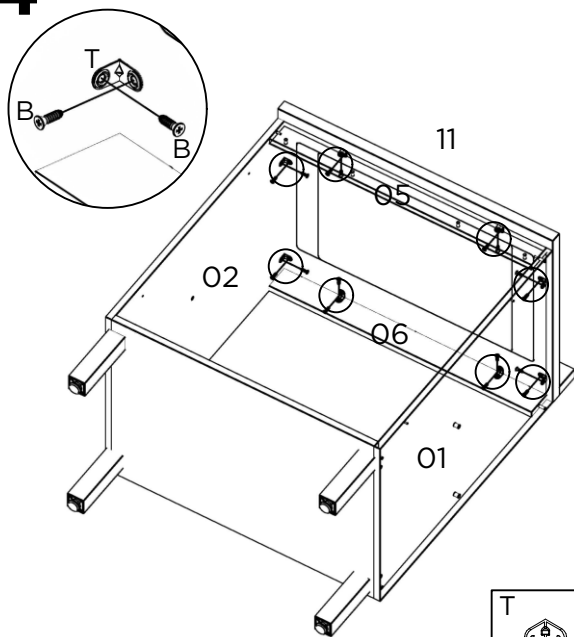
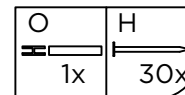
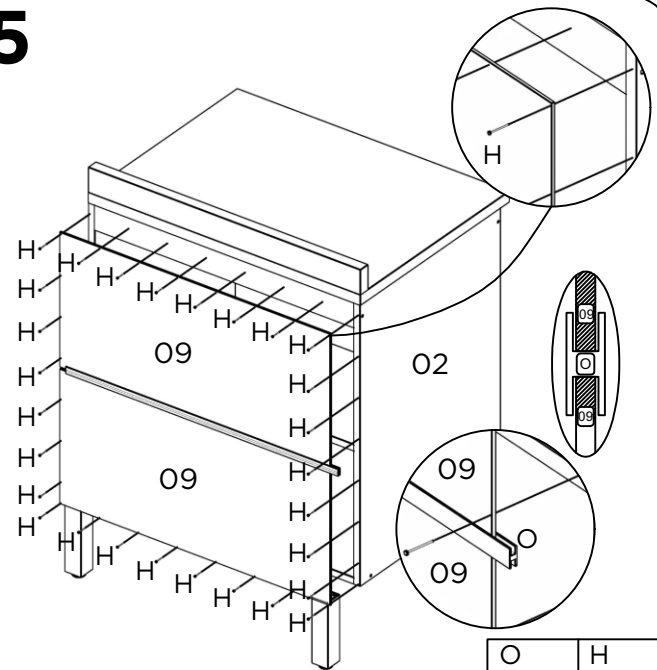
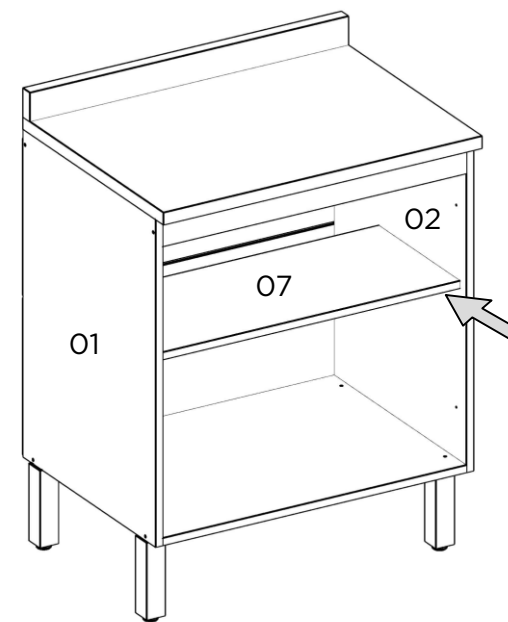
1**2****3****4****5****6**

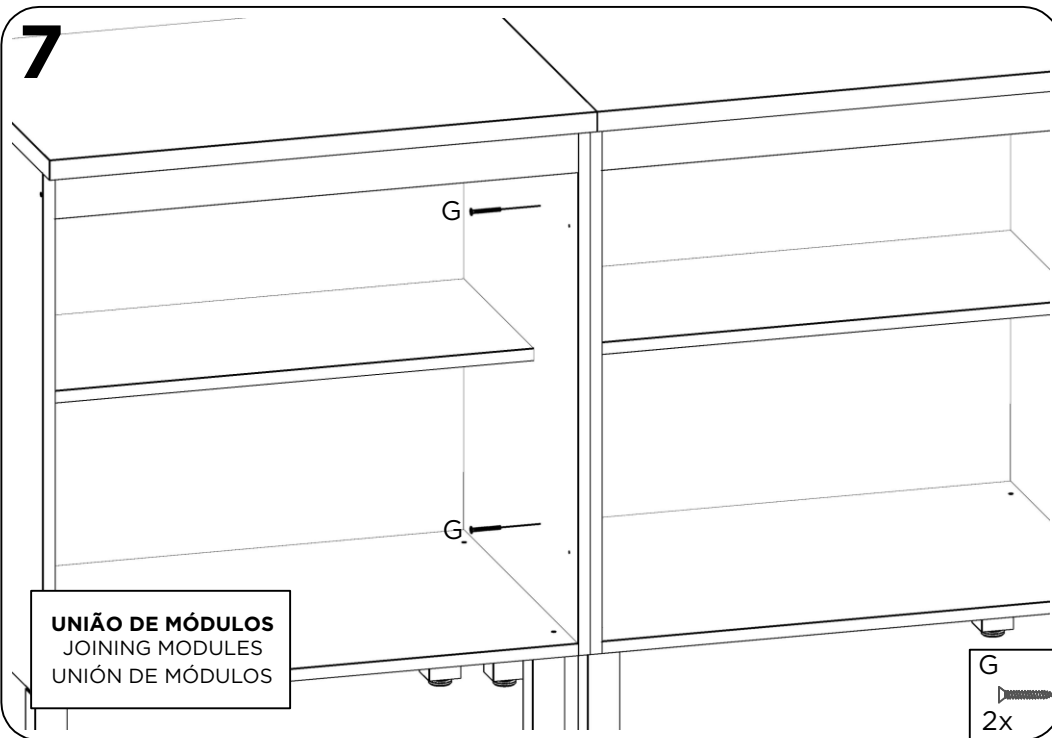
7

UNIÃO DE MÓDULOS
 JOINING MODULES
 UNIÓN DE MÓDULOS

G
 2x

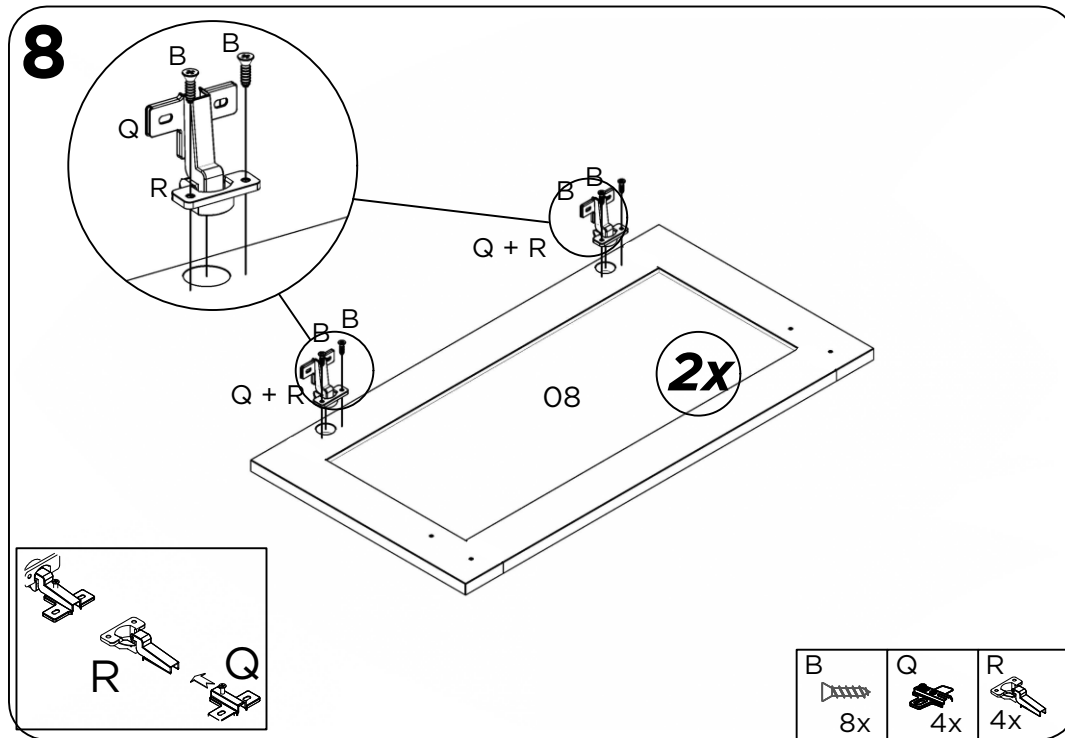
8

B 8x Q 4x R 4x

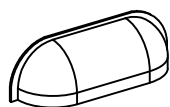
P

Parafuso 3,5x25mm

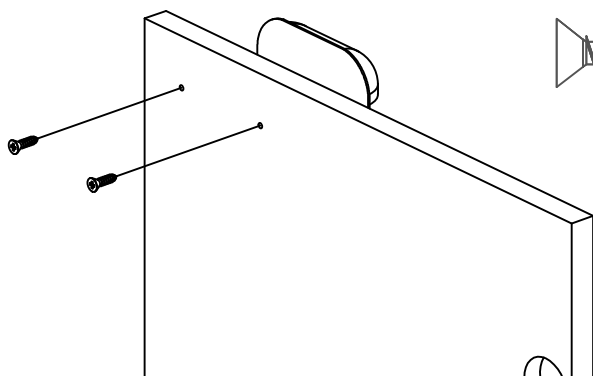
**9**

Instalação dos puxadores conforme modelo adquirido, siga os passos no manual dos puxadores.
 Instalación de las manijas según el modelo adquirido, seguir los pasos del manual de manijas.

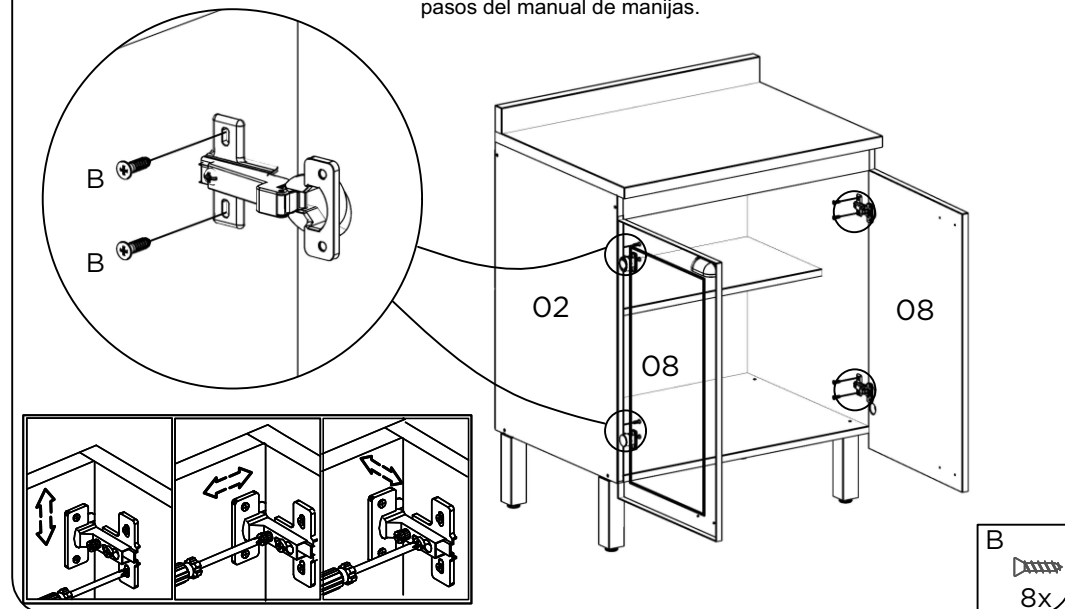

B 8x

MANUAL DE MONTAGEM / ASSEMBLY INSTRUCTIONS \ PLANO DE ARMADO

Antes de montar o móvel, leia com atenção o manual de montagem!

Before assembling the furniture, carefully read the assembly instructions

Antes de armar el mueble, lea con atención el manual de ensamble!

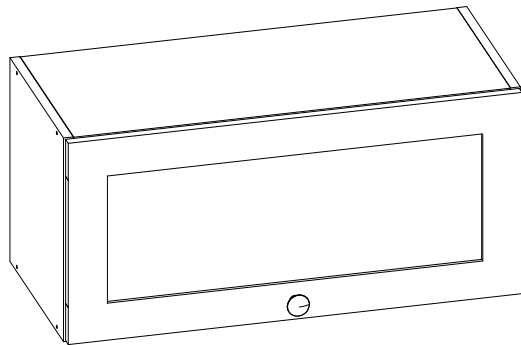

genialflex

Ref.: 1352

Parabéns! Você comprou um produto de excelente qualidade, fabricado com chapa de madeira de MDP ou MDF, extraída de florestas renováveis. Possui alta resistência e design atual.

Congratulations! You have purchased a product of excellent quality, made from MDP or MDF wood veneer, extracted from renewable forests. It has high strength and current design.

Felicitaciones! Usted compró a un producto de excelente calidad, fabricado con placa de madera de MDP o MDF, proveniente de florestas renovables. Tiene alta resistencia y diseño actual.



**ATENÇÃO
ATTENTION
ATENCIÓN**

1) Verifique todas as peças antes de começar a montagem.

Check all parts before starting assembly.

Verifique todas las partes antes de empezar el armado.

2) Ao começar a montagem, não apoie as peças na parede.

When starting the assembly, do not support the parts on the wall.

Al empezar el armado, no apoyes las partes en la pared.

3) Ao colocar as peças e ferragens de lado, cuidado para não perde-las.

When placing parts and hardware aside, be careful not to lose them.

Al poner las piezas y herrajes a parte, cuidado para no dañarlas.

4) O móvel deve ser montado no chão, para isso, use a própria caixa para proteger e não danificar o piso.

The furniture must be mounted on the floor, to do this, use the box it self to protect and not damage the floor.

El mueble suele ser armado al piso, para eso, use la propia caja para protegerlo y no dañar al piso.

5) Comece a montagem seguindo as instruções passo a passo.

Begin assembly by following the step-by-step.

Comience el armado siguiendo las instrucciones paso a paso.

6) É de responsabilidade do montador seguir as instruções desse manual, que são fundamentais para a estrutura do móvel.

It's the assembler's responsibility to follow the instructions in this manual, which are fundamental to the structure of the furniture.

Es de responsabilidad del armador seguir las instrucciones de este manual, que son fundamentales para la estructura del mueble.

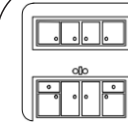

**CUIDADOS
CARE
CUIDADO**

1) A conservação e limpeza deve ser feita com um pano levemente umedecido com água.

Care and cleaning should be done with a cloth slightly moistened with water.

La conservación y limpieza debe ser hecha con un trapo levemente humedecido en agua.

2) Não use produtos abrasivos, como saponáceo, detergentes e esponja de aço.

Do not use abrasive products, such as soap, detergents and steel sponge.

No use productos abrasivos, como saponáceo, detergentes y esponja de acero.

3) Não use cera ou óleo para dar brilho ao móvel.

Do not use wax or oil to shine the furniture.

No use cera o aceites para darle brillo al mueble.

4) Não exponha o móvel a intempéries e nem ao calor excessivo.

Do not expose the furniture to weather or excessive heat.

No exponer el mueble a intemperies ni al calor excesivo.

5) Ao terminar a montagem, limpe o ambiente e o móvel.

When the assembly is finished, clean the room and the furniture.

Al terminar el armado, limpie al ambiente y al mueble.

FERRAMENTAS / TOOLS / HERRAMIENTAS



MARTELO
HAMMER
MARTILLO



MARTELO DE BORRACHA
RUBBER HAMMER
MARTILLO GOMA



NÃO RECOMENDÁVEL
NOT ADVISABLE
NO RECOMENDABLE



CHAVE PHILLIPS
PHILLIPS SCREWDRIVER
LLAVE PHILLIPS









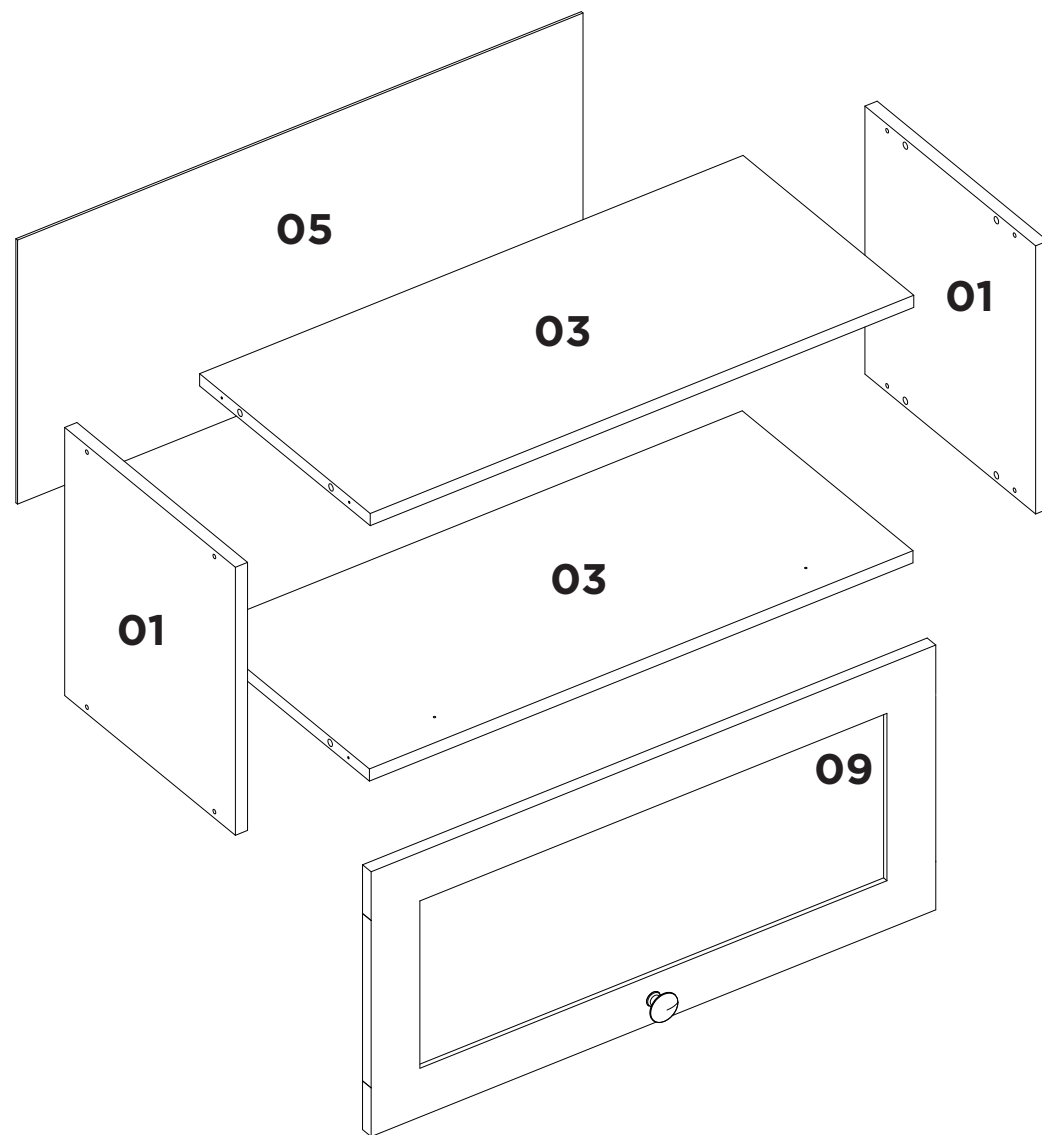





TRENA
MEASURING TAPE
CINTA MÉTRICA

PEÇAS / PARTS / PIEZAS

Nº No Num	DESCRIÇÃO DESCRIPTION DESCRIPCIÓN	QTD QTY CANT
02	LATERAL SIDE LATERAL	
02	BASE TOP TAPA	
01	COSTA BACK PANEL DORSO	
01	PORTA DOOR PUERTA	

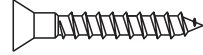

FERRAGENS / HARDWARE / HERRAJES

Nº No Num	DESCRIÇÃO DESCRIPTION DESCRIPCIÓN	QTD QTY CANT
A	 CAVILHA 8X30MM WOODEN DOWEL 8X30MM TARUGO 8X30MM	08
B	 PARAFUSO 3,5X40MM SCREW 3,5X40MM TORNILLO 3,5X40MM	08
C	 PREGO NAIL CLAVO	16
E	 PARAFUSO 4x14MM SCREW 4x14MM TORNILLO 4x14MM	15
G	 SUPORTE DE FIXAÇÃO MOUNTING SUPPORT SOPORTE DE MONTAJE	02
H	 PARAFUSO 5X50MM SCREW 5X50MM TORNILLO 5X50MM	02
I	 BUCHA PLÁSTICA PLASTIC BUSHING CASQUILLO PLÁSTICO	02
J	 CALÇO PARA DOBRADIÇA HINGE SHED CALZO DE BISAGRA	02
K	 DOBRADIÇA HINGE BIZAGRA	02
L	 PUXADOR PULLER TIRADOR	01
M	 PARAFUSO 3,5X25MM SCREW 3,5X25MM TORNILLO 3,5X25MM	02
N	 PARAFUSO 3,5X25MM SCREW 3,5X25MM TORNILLO 3,5X25MM	02
O	 PISTÃO PISTON PISTÓN	01
Q	 CAPA SUPORTE SUPPORT CAP CAPA SOPORTE	02

UTILIZE A RÉGUA PARA IDENTIFICAR OS PARAFUSOS.
USE THE RULER TO IDENTIFY THE SCREWS
UTILICE LA REGLA PARA IDENTIFICAR LOS TORNILLOS

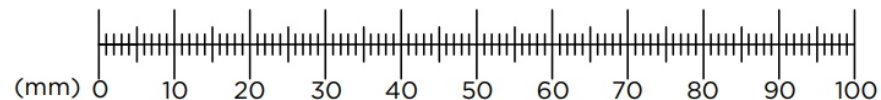

PESO SUPORTADO / WEIGHT SUPPORTED / PESO SOPORTADO

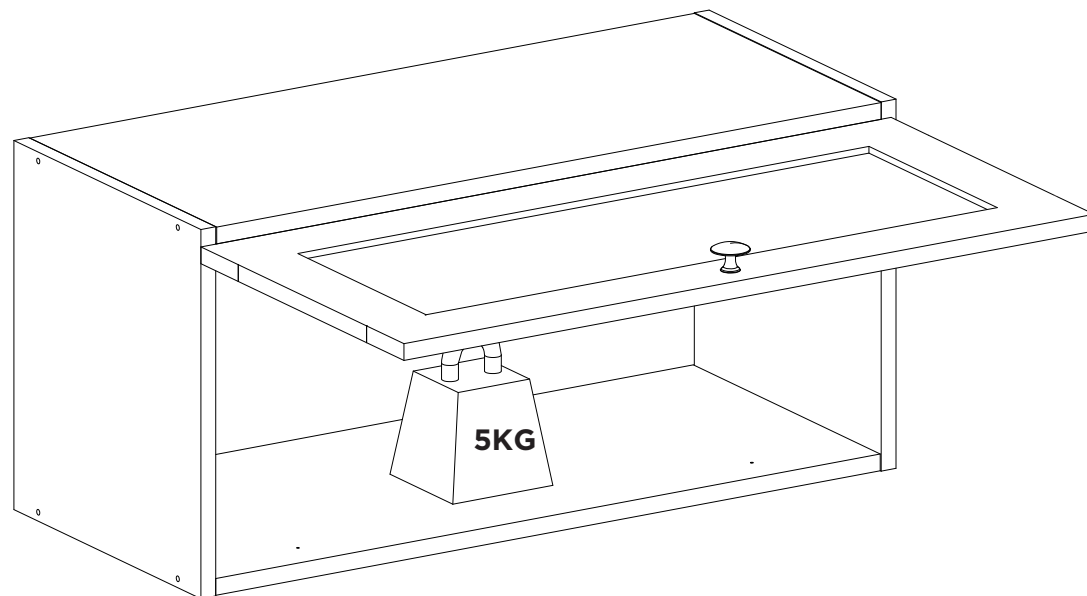

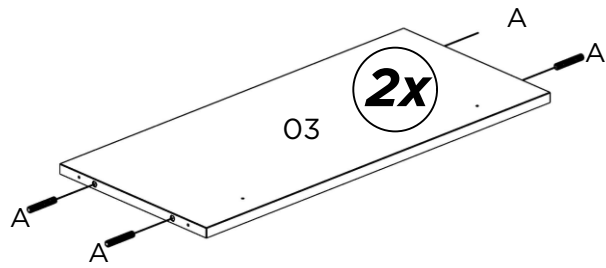
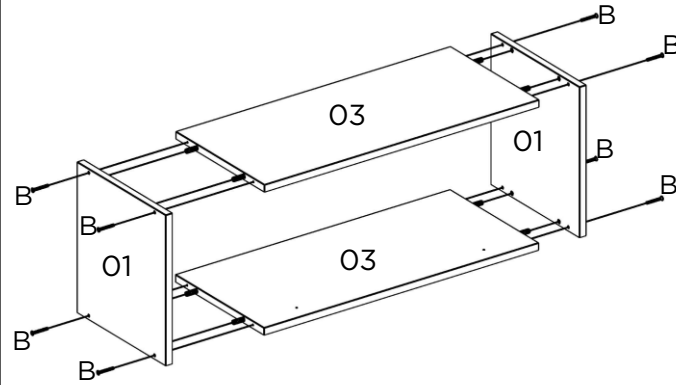
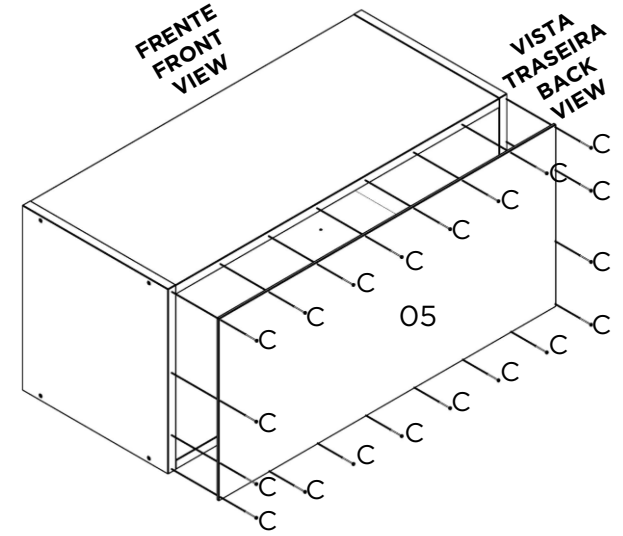
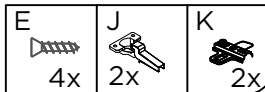
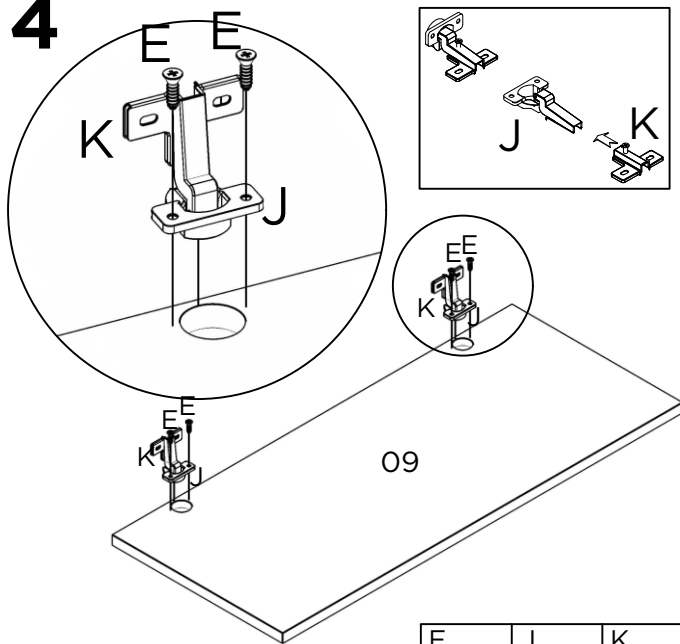
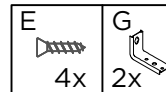
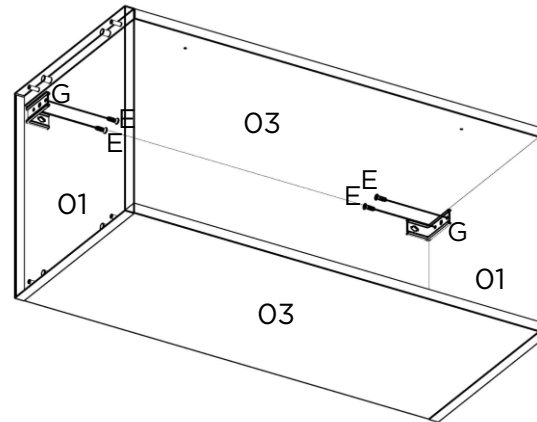
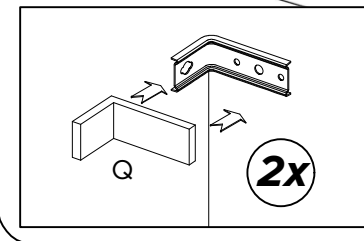
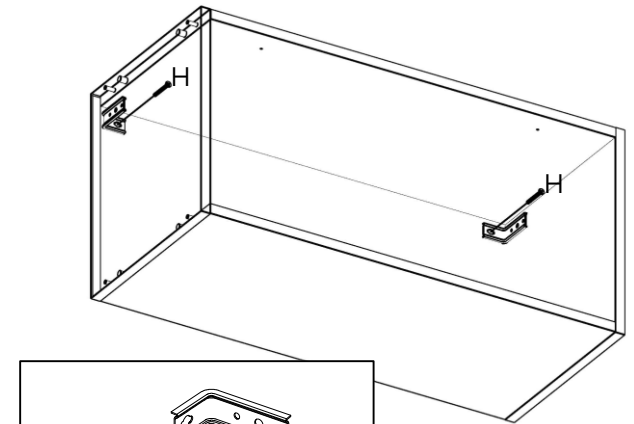
1**2****3****4****5****6**

**USE A BUCHA DE ACORDO COM O MATERIAL DA PAREDE
USE LA BUJE DE ACUERDO CON EL MATERIAL DE LA PARED
USE THE BUSHING ACCORDING TO THE WALL MATERIAL**

7

MATERIAL DA PAREDE: Painel de gesso ou estuque com viga de madeira;
SISTEMA DE FIXAÇÃO: Parafuso de fixação inserido diretamente na viga de madeira.

WALL MATERIAL: Plaster or stucco panel with wooden beam;
FIXING SYSTEM: Fixing screw inserted directly into the wooden beam.

MATERIAL DE LA PARED: Panel de yeso o estuco con viga de madera;
SISTEMA DE FIJACIÓN: Tornillo de fijación insertado directamente en la viga de madera.

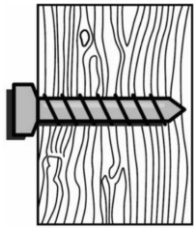

MATERIAL DA PAREDE: Painel de gesso sem viga de madeira;
SISTEMA DE FIXAÇÃO: Parafuso de fixação com bucha plástica.

WALL MATERIAL: Plaster panel without wooden beam;
FIXING SYSTEM: Fixing screw with plastic bushing.

MATERIAL DE LA PARED: Panel de yeso sin viga de madera;
SISTEMA DE FIJACIÓN: Tornillo de fijación con buje de plástico.

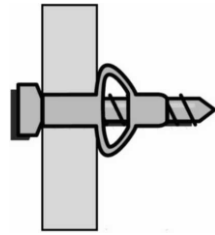



MATERIAL DA PAREDE: Alvenaria (concreto ou tijolo);
SISTEMA DE FIXAÇÃO: Parafuso de fixação com bucha.

WALL MATERIAL: Masonry (concrete or brick);
FIXING SYSTEM: Fixing screw with plastic bushing.

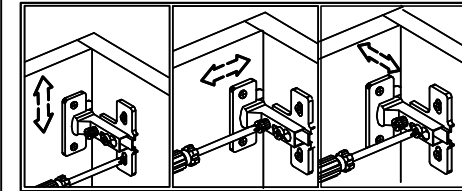
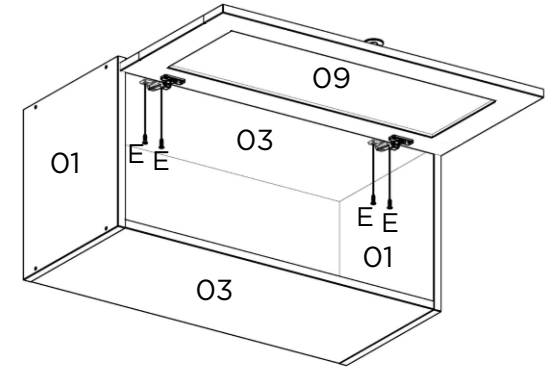
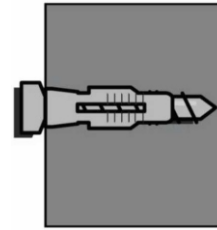
MATERIAL DE LA PARED: Albañilería (hormigón o ladrillo);
SISTEMA DE FIJACIÓN: Tornillo de fijación con buje de plástico.



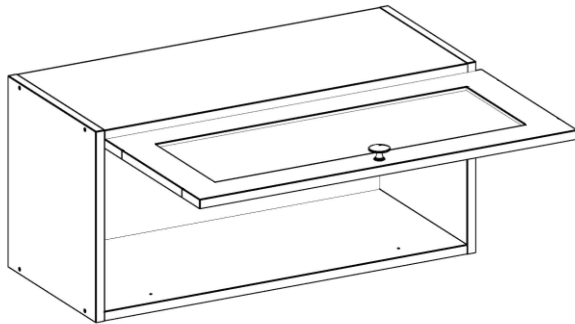

E	J	K
		
4x	2x	2x

8



PARA EFETUAR A INSTALAÇÃO DO PISTÃO, SIGA OS PASSOS NO MANUAL QUE O ACOMPANHA.

TO INSTALL THE PISTON, FOLLOW THE STEPS IN THE ACCOMPANYING MANUAL.
PARA INSTALAR EL PISTÓN SEGUIR LOS PASOS DEL MANUAL ADJUNTO.

L	E
	
1x	3x

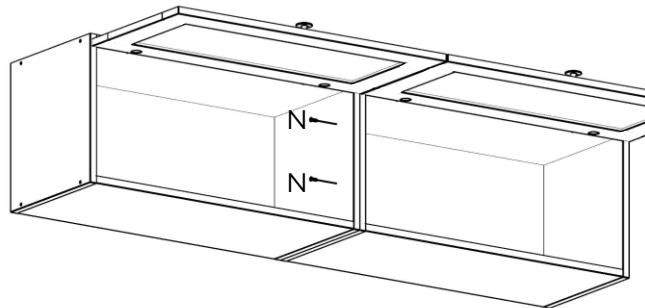

UNIÃO DE MÓDULOS
JOINING MODULES
UNIÓN DE MÓDULOS

N

2x

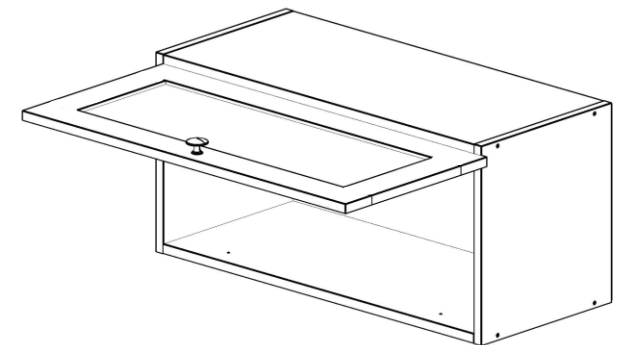

MONTAGEM DOS PUXADORES
HANDLE ASSEMBLY
MONTAGE DEL TIRADOR

MANUAL DE MONTAGEM / ASSEMBLY INSTRUCTIONS / PLANO DE ARMADO

Antes de montar o móvel, leia com atenção o manual de montagem!
Before assembling the furniture, carefully read the assembly instructions!
Antes de armar el mueble, lea con atención el manual de ensamble!

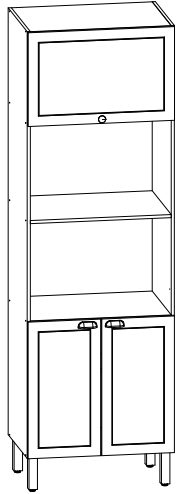

Ref.: 1356

geniaflex
ambientes incríveis para todos

Parabéns! Você comprou um produto de excelente qualidade, fabricado com chapa de madeira de MDP ou MDF, extraída de florestas renováveis. Possui alta resistência e design atual.

Congratulations! You have purchased a product of excellent quality, made from MDP or MDF wood veneer, extracted from renewable forests. It has high strength and current design.

Felicitaciones! Usted compró a un producto de excelente calidad, fabricado con placa de madera de MDP o MDF, proveniente de florestas renovables. Tiene alta resistencia y diseño actual.



**ATENÇÃO
ATTENTION
ATENCIÓN**

1) Verifique todas as peças antes de começar a montagem.

Check all parts before starting assembly.

Verifique todas las partes antes de empezar el armado.

2) Ao começar a montagem, não apoie as peças na parede.

When starting the assembly, do not support the parts on the wall.

Al empezar el armado, no apoyes las partes en la pared.

3) Ao colocar as peças e ferragens de lado, cuidado para não perde-las.

When placing parts and hardware aside, be careful not to lose them.

Al poner las piezas y herrages a parte, cuidado para no dañarlas.

4) O móvel deve ser montado no chão, para isso, use a própria caixa para proteger e não danificar o piso.

The furniture must be mounted on the floor, to do this, use the box itself to protect and not damage the floor.

El mueble suele ser armando al piso, para eso, use la propia caja para protegerlo y no dañar al piso.

5) Comece a montagem seguindo as instruções passo a passo.

Begin assembly by following the step-by-step instructions.

Comience el armado siguiendo la instrucciones paso a paso.

6) É de responsabilidade do montador seguir as intruções desse manual, que são fundamentais para a estrutura do móvel.

It's the assembler's responsibility to follow the instructions in this manual, which are fundamental to the structure of the furniture.

Es de responsabilidad del armador seguir las instrucciones de este manual, que son fundamentales para la estructura del mueble.

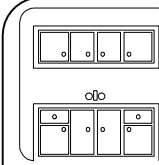

**CUIDADOS
CARE
CUIDADO**

1) A conservação e limpeza deve ser feita com um pano levemente umedecido com água.

Care and cleaning should be done with a cloth slightly moistened with water.

La conservación y limpieza debe ser hecha con un trapo levemente humedecido en agua.

2) Não use produtos abrasivos, como saponáceo, detergentes e esponja de aço.

Do not use abrasive products, such as soap, detergents and steel sponge.

No use productos abrasivos, como saponáceo, detergentes y esponja de acero.

3) Não use cera ou óleo para dar brilho ao móvel.

Do not use wax or oil to shine the furniture.

No use cera o aceites para darle brillo al mueble.

4) Não expor o móvel a interperies e nem ao calor excessivo.

Do not expose the furniture to weather or excessive heat.

No exponer el mueble a interperies ni al calor excesivo.

5) Ao terminar a montagem, limpe o ambiente e o móvel.

When the assembly is finished, clean the room and the furniture.

Al terminar el armado, limpie al ambiente y al mueble.

FERRAMENTAS / TOOLS / HERRAMIENTAS



MARTELO
HAMMER
MARTILLO



NAO RECOMENDAVEL
NOT ADVISABLE
NO RECOMENDABLE



CHAVE PHILLIPS
PHILLIPS SCREWDRIVER
LLAVE PHILLIPS











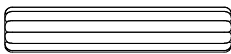

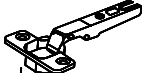

MARTELO DE BORRACHA
RUBBER HAMMER
MARTILLO GOMA

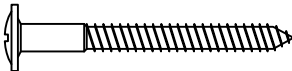

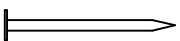
TRENA
MEASURING TAP
CINTA MÉTRICA

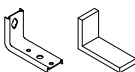
FERRAGENS / HARDWARE / HERRAJES

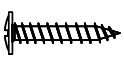
CÓD CODE COD	DESCRIÇÃO DESCRIPTION DESCRIPCIÓN	QTD QTY CANT
A	 CAVILHA WOODEN DOWEL TARUGO	20
B	 SUPORTE DE PRATELEIRA SHELF SUPPORT SOPORTE DE ESTANTES	4
C	 PARAFUSO 4X14mm SCREW 4X14mm TORNILLO 4X14mm	33
D	 DOBRADIÇA HINGE BIZAGRA	6
E	 CALÇO PARA DOBRADIÇA HINGE SHED CALZO DE BISAGRA	6
F	 PUXADOR PULLER TIRADOR	3
G	 PÉ LEG PATA	4
H	 PARAFUSO 5X50mm SCREW 5X50mm TORNILLO 5X50mm	5
I	 PARAFUSO 3,5X40mm SCREW 3,5X40mm TORNILLO 3,5X40mm	20
J	 PREGO NAIL CLAVO	60
K	 PERFIL I PROFILE I PERFIL I	1
L	 PARAFUSO 3,5X25mm SCREW 3.5X25mm TORNILLO 3.5X25mm	5
M	 SUPORTE DE FIXAÇÃO MOUNTING SUPPORT SOPORTE DE MONTAJE	1
N	 BUCHA PLÁSTICA PLASTIC BUSHING CASQUILLO PLÁSTICO	1
O	 PISTÃO PISTON PISTÓN	1
P	 PARAFUSO 3.5X25mm SCREW 3.5X25mm TORNILLO 3.5X25mm	6

UTILIZE A RÉGUA PARA IDENTIFICAR OS PARAFUSOS
USE THE RULER TO IDENTIFY THE SCREWS
UTILICE LA REGLA PARA IDENTIFICAR LOS TORNILLOS



PESO SUPORTADO / WEIGHT SUPPORTED / PESO SOPORTADO

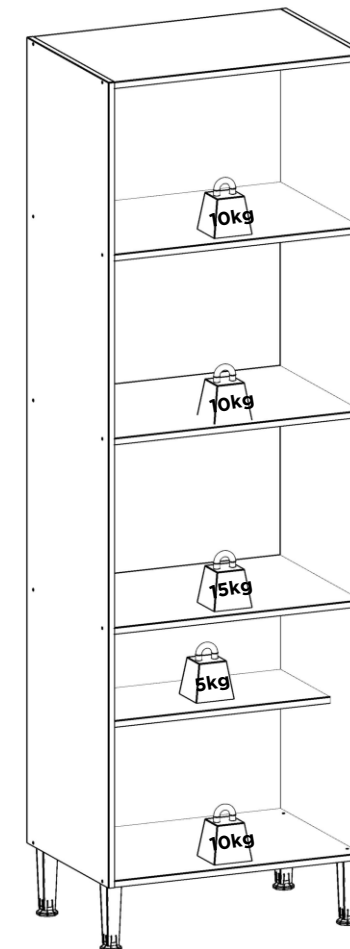

PEÇAS / PARTS / PIEZAS

Nº No Num	DESCRIÇÃO DESCRIPTION DESCRIPCIÓN	QTD QTY CANT
1	LATERAL DIREITA RIGHT SIDE PANEL LATERAL DERECHA	1
2	LATERAL ESQUERDA LEFT SIDE PANEL LATERAL IZQUIERDA	1
3	BASE BOTTOM BASE	1
4	TAMPO TOP TABLERO	1
5	COSTA INFERIOR LOWER BACK PANEL TRASERO INFERIOR	2
7	PRATELEIRA PLATE PANEL REPISA	1
8	PORTA DOOR PUERTA	2
9	PORTA BASCULANTE TILTING DOOR PUERTA BASCULANTE	1
12	BASE / PRATELEIRA BOTTOM PANEL / PLATE PANEL BASE / REPISA	3
13	COSTA SUPERIOR UPPER BACK PANEL TRASERO SUPERIOR	1

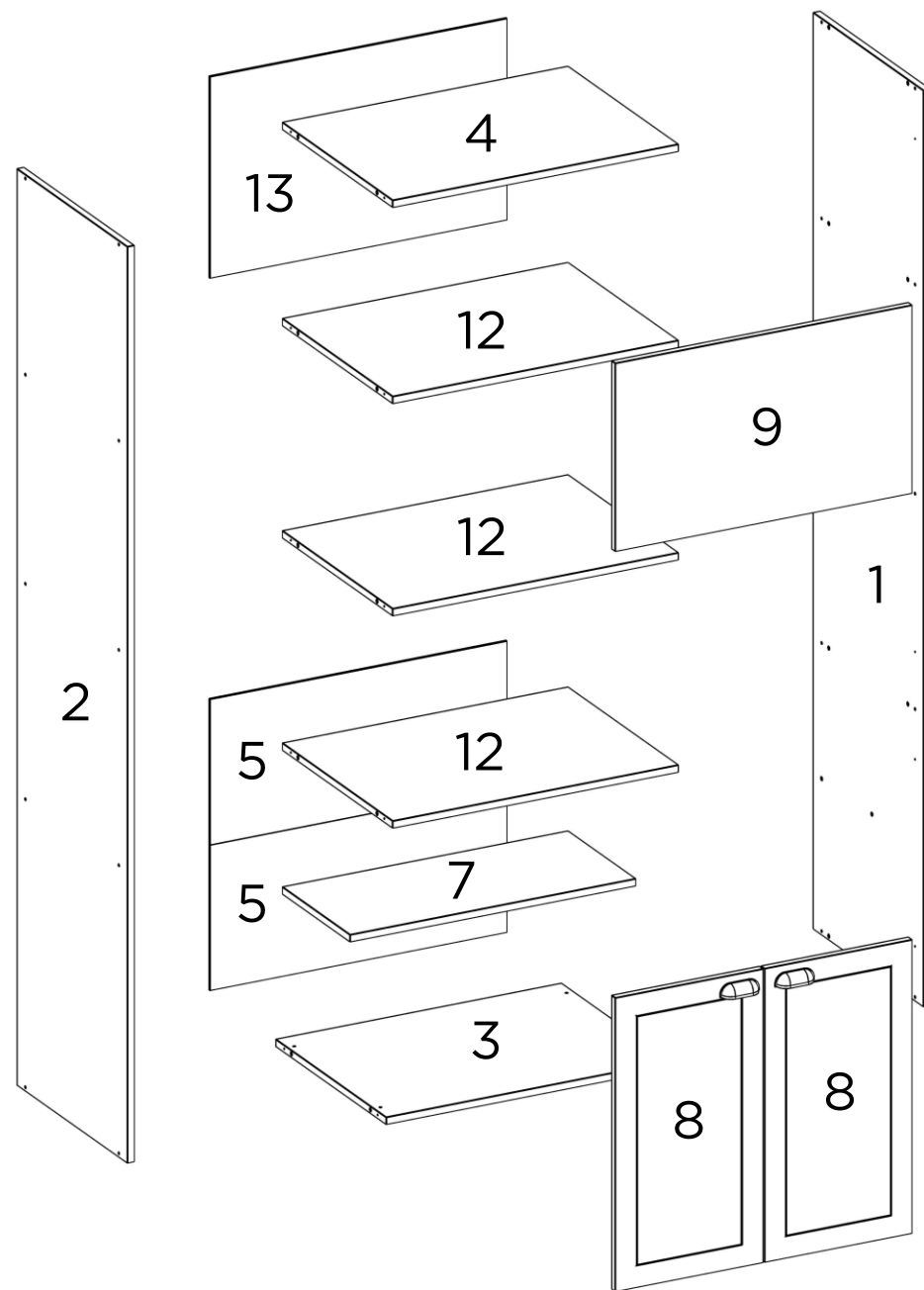

7

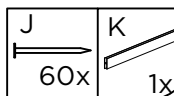
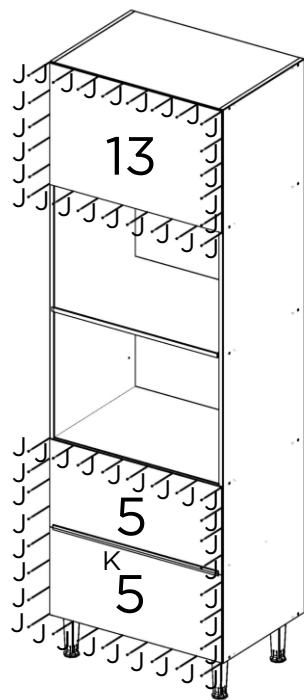

8

UNIÃO DE MÓDULOS
JOINING MODULES
UNIÓN DE MÓDULOS

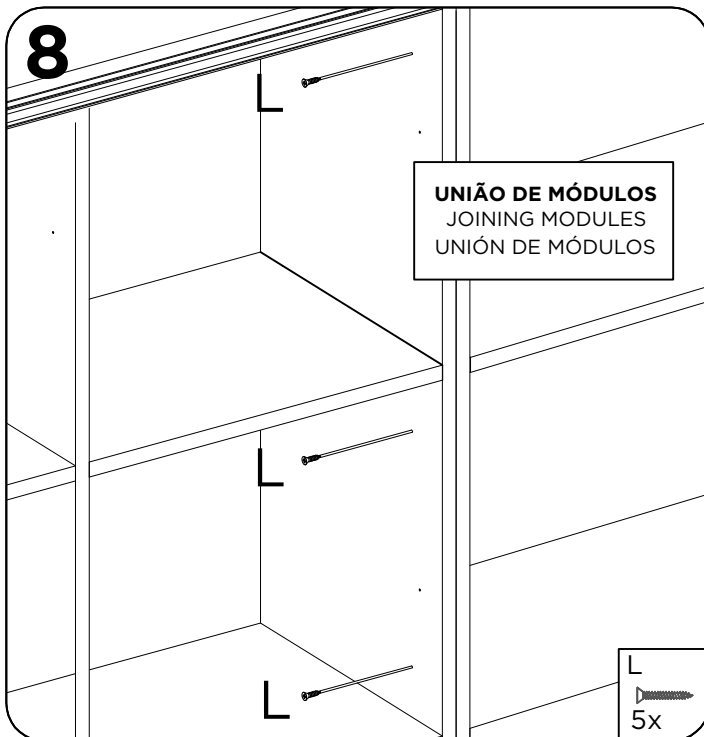

9

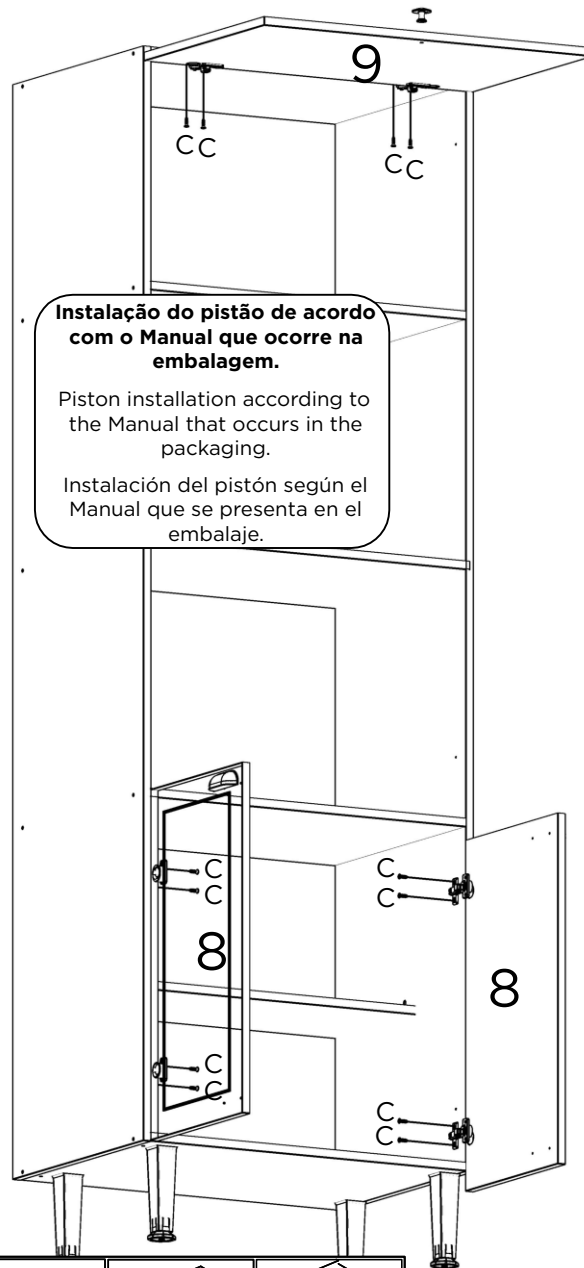

Instalação do pistão de acordo com o Manual que ocorre na embalagem.

Piston installation according to the Manual that occurs in the packaging.

Instalación del pistón según el Manual que se presenta en el embalaje.

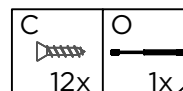
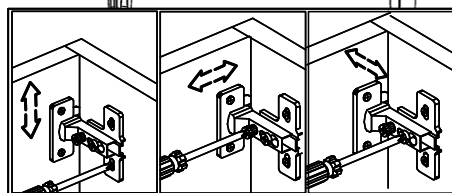

10

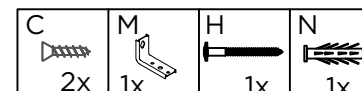
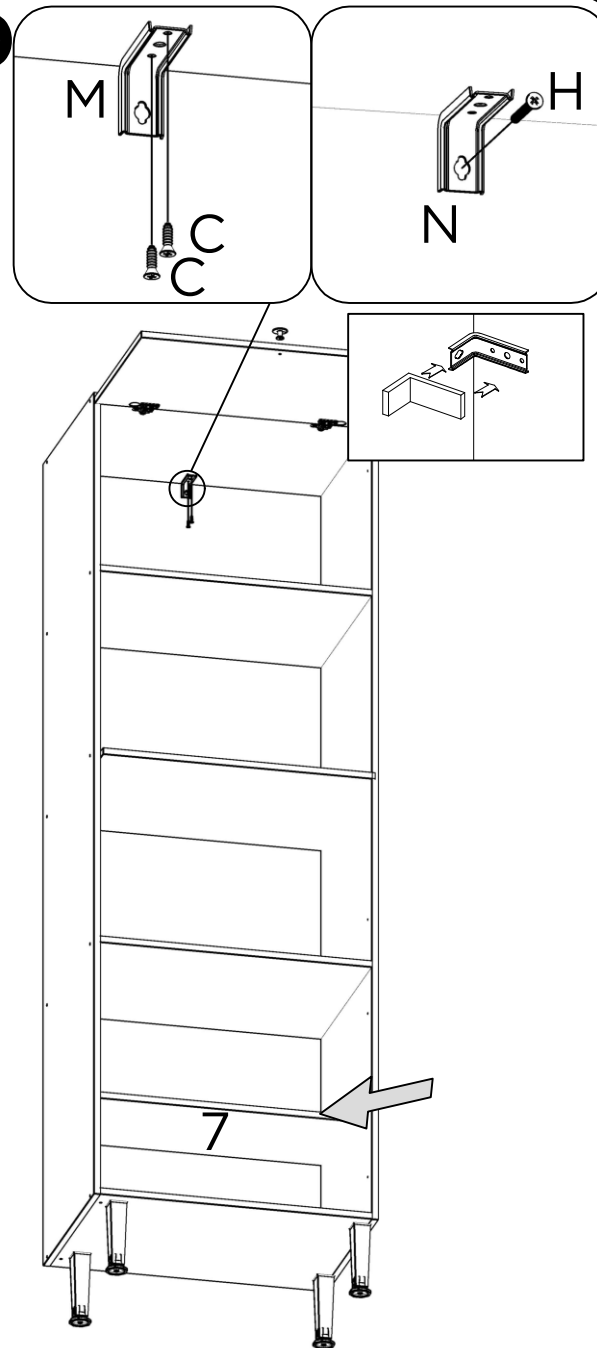

P

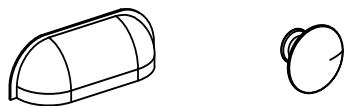

Parafuso 3,5x25mm

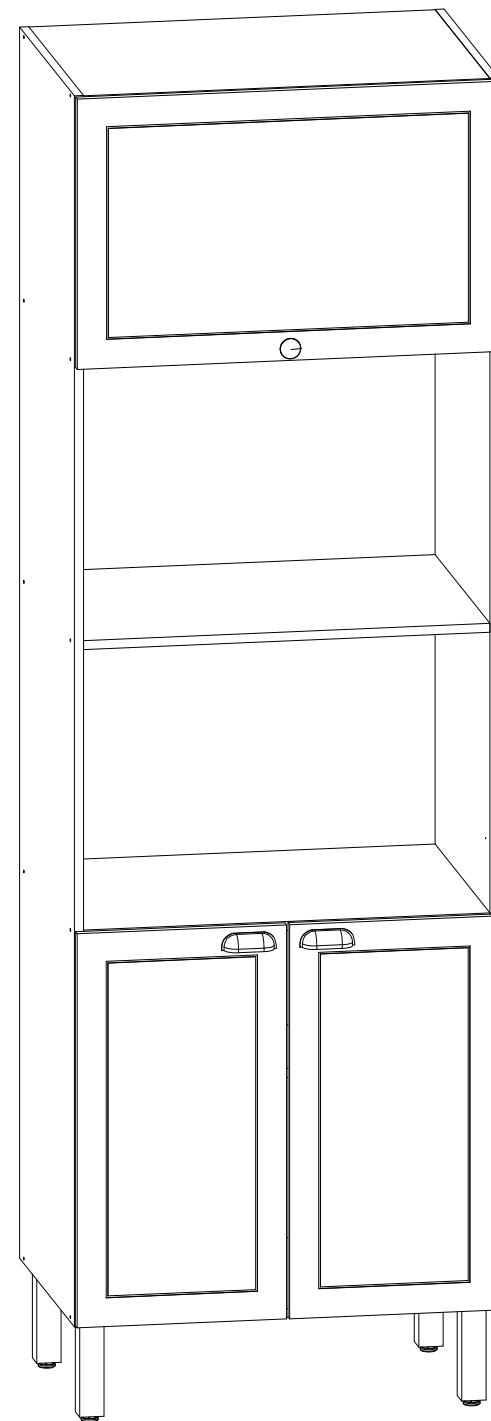
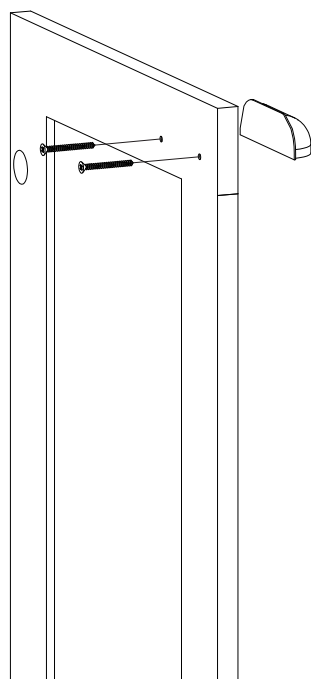
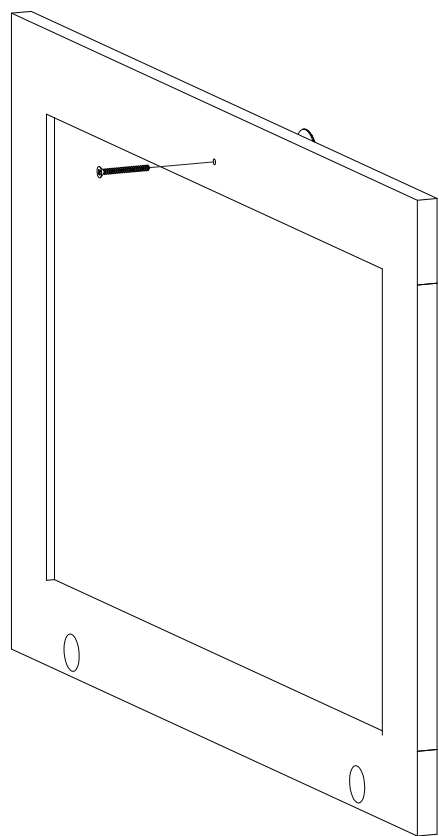
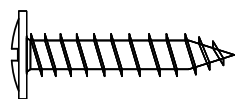

MANUAL DE MONTAGEM / PLANO DE ARMADO

Parabéns! Você comprou um produto de excelente qualidade, fabricado com chapa de madeira de MDP ou MDF, extraída de florestas renováveis. Possui alta resistência e design atual.

Felicitaciones! Usted compró a un producto de excelente calidad, fabricado con placa de madera de MDP o MDF, proveniente de florestas renovables. Tiene alta resistencia y diseño actual.

Antes de montar o móvel, leia com atenção o manual de montagem!
Antes de armar el mueble, lea con atención el manual de ensamble!

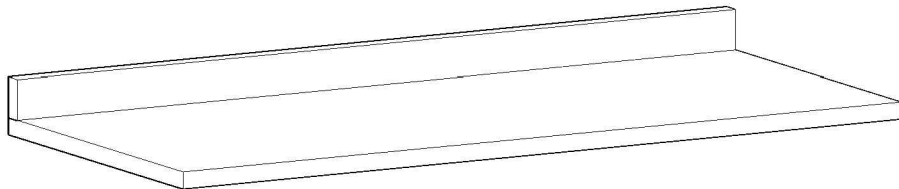

Ref.: 0298



ATENÇÃO:
ATENCIÓN:

- 1) Verifique todas as peças antes de começar a montagem.**
Verifique todas las partes antes de empezar el armado.
- 2) Ao começar a montagem, não apoie as peças na parede.**
Al empezar el armado, no apoyes las partes en la pared.
- 3) Ao colocar as peças e ferragens de lado, cuidado para não perde-las.**
Al poner las piezas y herrages a parte, cuidado para no dañarlas.
- 4) O móvel deve ser montado no chão, para isso, use a própria caixa para proteger e não danificar o piso.**
El mueble suele ser armando al piso, para eso, use la propia caja para protegerlo y no dañar al piso.
- 5) Comece a montagem seguindo as instruções passo a passo.**
Comience el armado siguiendo la instrucciones paso a paso.
- 6) É de responsabilidade do montador seguir as intruções desse manual, que são fundamentais para a estrutura do móvel.**
Es de responsabilidad del armador seguir las instrucciones de este manual, que son fundamentales para la estructura del mueble.

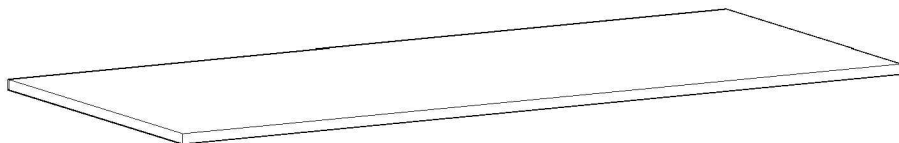

Ref.: 0299

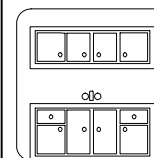

CUIDADOS:
CUIDADOS:

- 1) A conservação e limpeza deve ser feita com um pano levemente umedecido com água.**
La conservación y limpieza debe ser hecha con un trapo levemente humedecido en agua.
- 2) Não use produtos abrasivos, como saponáceo, detergentes e esponja de aço.**
No use productos abrasivos, como saponáceo, detergentes y esponja de acero.
- 3) Não use cera ou óleo para dar brilho ao móvel.**
No use cera o aceites para darle brillo al mueble.
- 4) Não expor o móvel a interpéries e nem ao calor excessivo.**
No exponer el mueble a interperies ni al calor excesivo.
- 5) Ao terminar a montagem, limpe o ambiente e o móvel.**
Al terminar el armado, limpie al ambiente y al mueble.

Antes de começar a montagem certifique-se que as caixas estão em perfeitas condições.

Antes de empezar el armado asegúrese que las cajas estén en perfectas condiciones.

geniaflex
ambientes incríveis para todos

FERRAMENTAS:
HERRAMIENTAS:

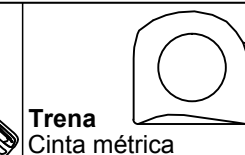



Ref.: 0298

LISTA DE PEÇAS / LISTA DE PIEZAS

Nº	Descrição / Descripción	Qtd. Cant.
1	Tampo / Tablero	1
2	Espelho / Espejo	1

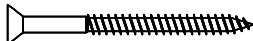
LISTA DE FERRAGENS / LISTA DE HERRAJES

ITEM ITEM	DESCRIÇÃO / DESCRIPCIÓN	QTD. CANT.
P1	 PARAFUSO 4X14 TORNILLO 4X14	16
P16	 PARAFUSO 4X60 TORNILLO 4X60	4
S1	 CHAPA "L" 2 FUROS PLACA "L" 2 AGUJEROS	8

USE A RÉGUA PARA IDENTIFICAR OS PARAFUSOS
UTILICE LA REGLA PARA IDENTIFICAR LOS TORNILLOS

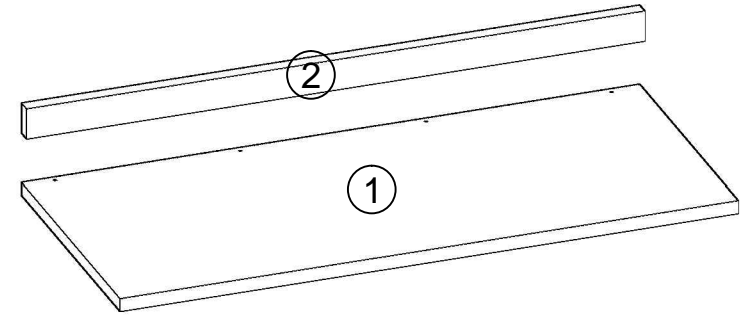
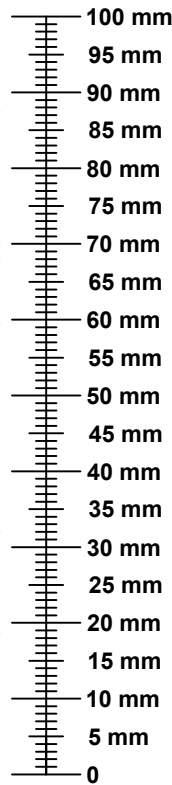

1

FIXE O ESPELHO (2) NO TAMPO (1)
FIJE EL ESPEJO (2) EN EL TABLERO (1)

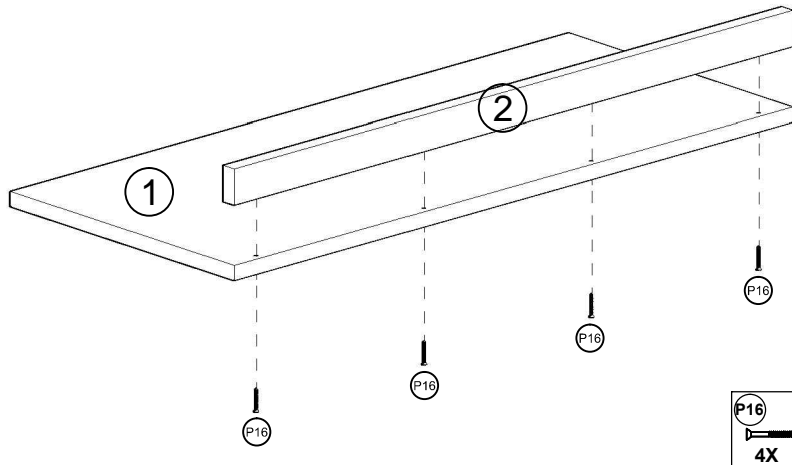

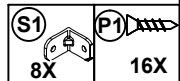
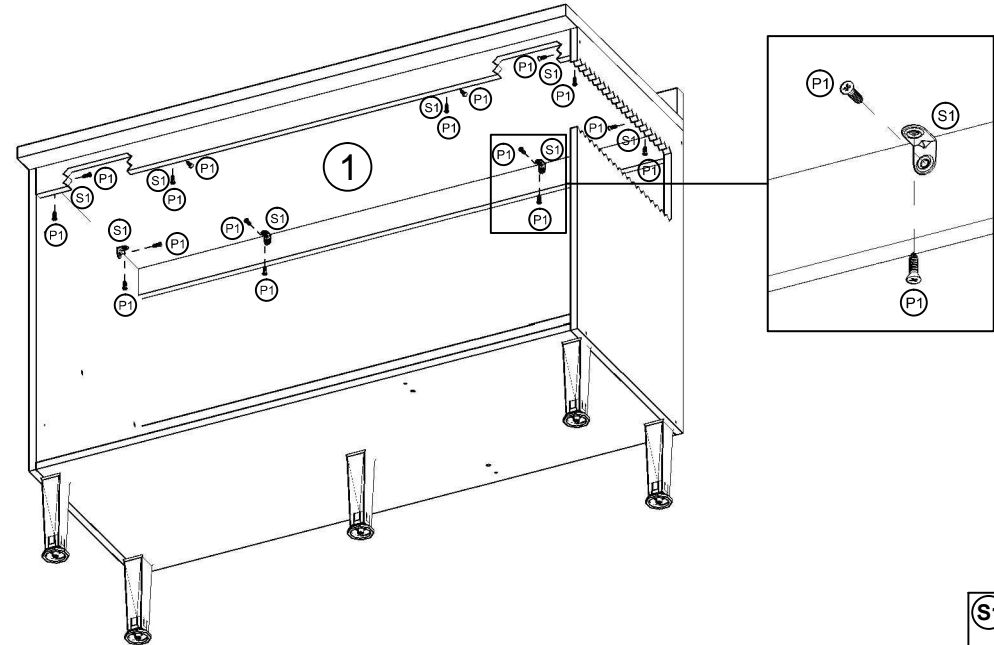

2

FIXE O TAMPO (1) NO BALCÃO
FIJE EL TABLERO (1) EN EL MUEBLE BAJO



Ref.: 0299

LISTA DE PEÇAS / LISTA DE PIEZAS		
Nº	Descrição / Descripción	Qtd. Cant.
1	Tampo / Tablero	1

LISTA DE FERRAGENS / LISTA DE HERRAJES			
ITEM ITEM	DESCRIÇÃO / DESCRIPCIÓN	QTD. CANT.	
P1	 PARAFUSO 4X14 TORNILLO 4X14	16	
S1	 CHAPA "L" 2 FUROS PLACA "L" 2 AGUJEROS	8	

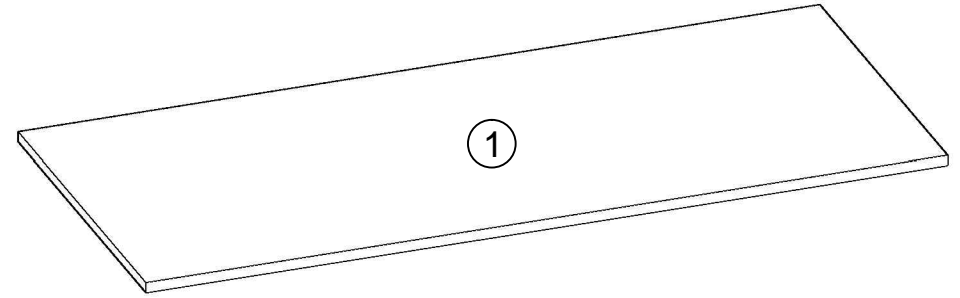
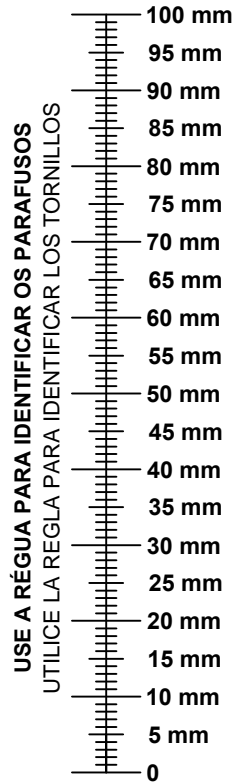

1
FIXE O TAMPO (1) NO BALCÃO
FIJE EL TABLERO (1) EN EL
MUEBLE BAJO

