

ASSEMBLY INSTRUCTIONS MANUAL DE MONTAGEM / INSTRUCCIONES DE ARMADO

PANTRY CABINET 2 DOORS COUNTERTOP 19 5/16"

PANELEIRO 2P TAMPO 490MM

DESPENSERO 2 PUERTAS ENCIMERA 490MM

Reference
Referência
Referencia **240534**

Revise
Revisão
Revisión **00**

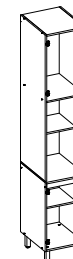

YOU WILL NEED VOCÊ VAI PRECISAR DE / USTED NECESITARÁ

Tools not supplied
Ferramentas não fornecidas / Herramientas no incluidas

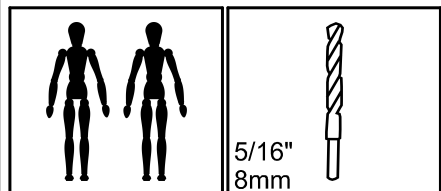

2 People
2 Pessoas
2 Personas

Drill bit
Broca
Taladro

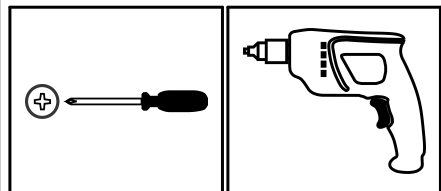

Screwdriver Phillips
Chave Phillips
Destornillador cruz

Drill machine
Furadeira
Taladro

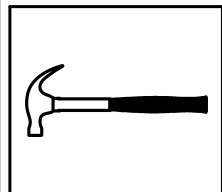

Hammer
Martelo
Martillo

 MAXIMUM RECOMMENDED WEIGHT BEING THIS EVENLY DISTRIBUTED.
PESO MÁXIMO RECOMENDADO SENDO ESTE DISTRIBUÍDO UNIFORMEMENTE.
PESO MÁXIMO RECOMENDADO SIENDO ESTE UNIFORMEMENTE DISTRIBUIDO.

	LB	KG
—		
F	22	10

PARTS IDENTIFICATION IDENTIFICAÇÃO DAS PEÇAS / IDENTIFICACIÓN DE LAS PIEZAS

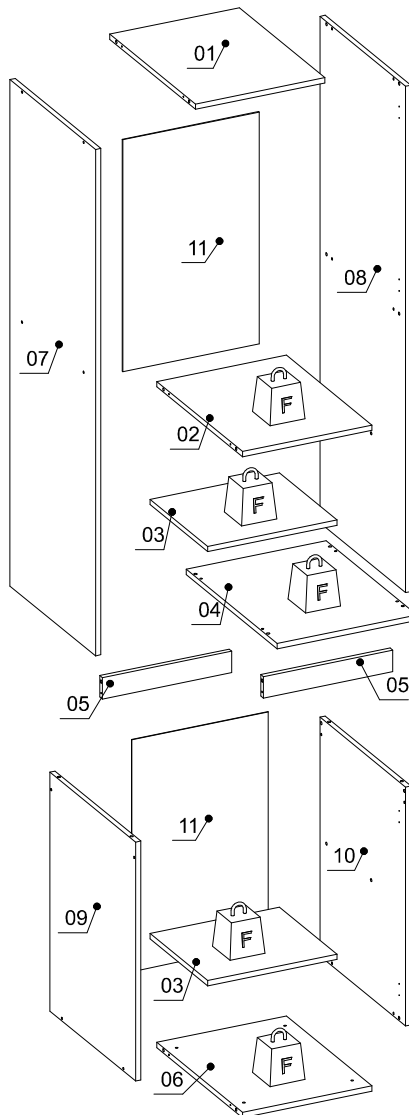

Nº	Measures_Inches	Medidas_cm	Qty./Qtd.
01	14 5/8 x 19 1/4 x 5/8	37.0 x 49.0 x 1.5	1
02	14 5/8 x 19 1/4 x 5/8	37.0 x 49.0 x 1.5	1
03	14 5/8 x 13 x 5/8	37.0 x 33.0 x 1.5	2
04	15 3/4 x 20 1/2 x 5/8	40.0 x 52.0 x 1.5	1
05	14 5/8 x 2 3/8 x 5/8	37.0 x 6.0 x 1.5	2
06	14 5/8 x 19 1/4 x 5/8	37.0 x 49.0 x 1.5	1
07	55 7/8 x 19 1/4 x 5/8	142.0 x 49.0 x 1.5	1
08	55 7/8 x 19 1/4 x 5/8	142.0 x 49.0 x 1.5	1
09	26 3/8 x 19 1/4 x 5/8	67.0 x 49.0 x 1.5	1
10	26 3/8 x 19 1/4 x 5/8	67.0 x 49.0 x 1.5	1
11	25 5/8 x 15 3/8 x 1/8	65.0 x 39.0 x 0.3	2

IDENTIFICATION OF ACCESSORIES IDENTIFICAÇÃO DOS ACESSÓRIOS/ IDENTIFICACIÓN DE ACCESORIOS



The separation of the accessories before you start the assembly will facilitate the same. In case of doubt on the size of the screws and bolts, use the ruler at the bottom of the page.
 A separação dos acessórios antes de iniciar a montagem facilitará a mesma. Em caso de dúvida no tamanho dos parafusos e cavilhas, utilize a régua ao final da página.
 La separación de los accesorios antes de comenzar el armado facilitará el mismo. En caso de duda sobre el tamaño de los tornillos y taquetes, utilice la regla al pie de página.

A		Flanged head screw Parafuso flangeado / Tornillo de cabeza flangeada	5,0x60 mm	2
A23		Foot Pé Quadrado FP / Pie	140 mm	4
A4		Metalic bracket Cantoneira de metal / Soporte de metal	22x22 mm	6
B3		Bushing Buchta expansiva / Tapón	8x50 mm	2
C		Flanged head screw Parafuso flangeado / Tornillo de cabeza flangeada	4,5x45 mm	4
D5		Hinge shim Calço dobradiça / Bisagra de calce	-	4
E		Wooden dowel Cavilha / Taquete	8x30 mm	16
E3		Shelf bracket Suporte de prateleira / Soporte de repisa	8x7 mm	8
F		Wooden dowel Cavilha / Taquete	8x50 mm	4
F9		Metal hinge straight Dobradiça reta / Bisagra recta	26 mm	4
N		Nail Prego / Clavo	10x10	40
N5		Support "L" Suporte "L" / Soporte "L"	-	2
O		Flat head screw Parafuso chato / Tornillo de cabeza plana	4,5x45 mm	20
S		Pan head screw Parafuso panela / Tornillo de pan	3,5x14 mm	32



PRE-ASSEMBLE / PRÉ-MONTAGEM / PRE ARMADO

01

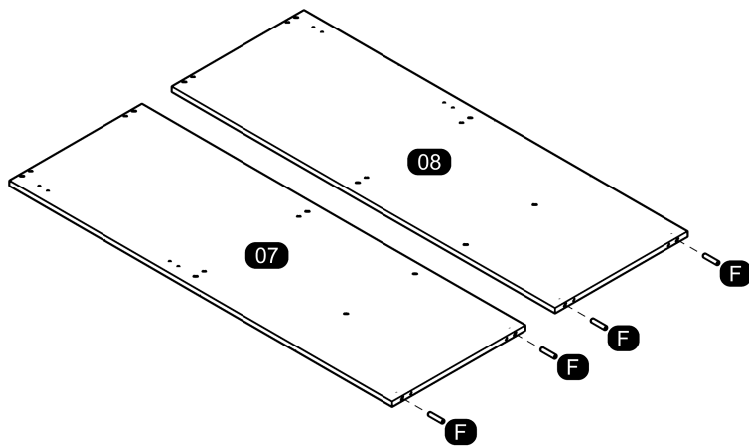
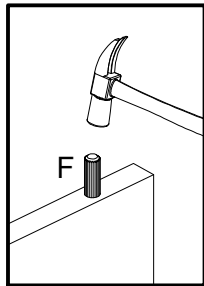

02

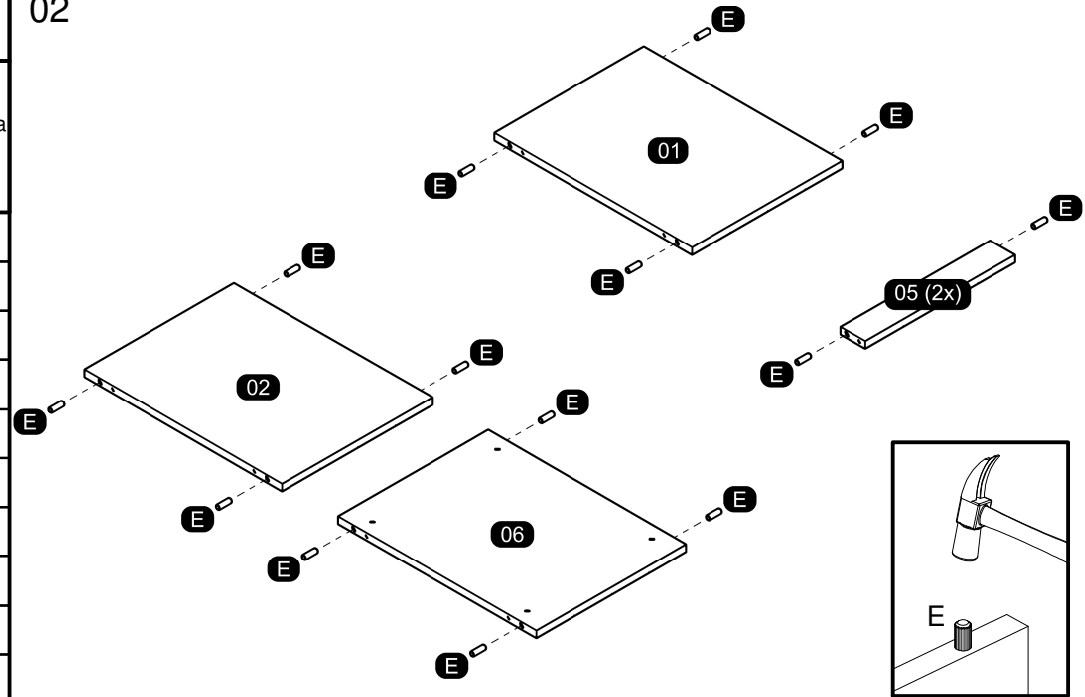

ASSEMBLY MONTAGEM / ARMADO

03

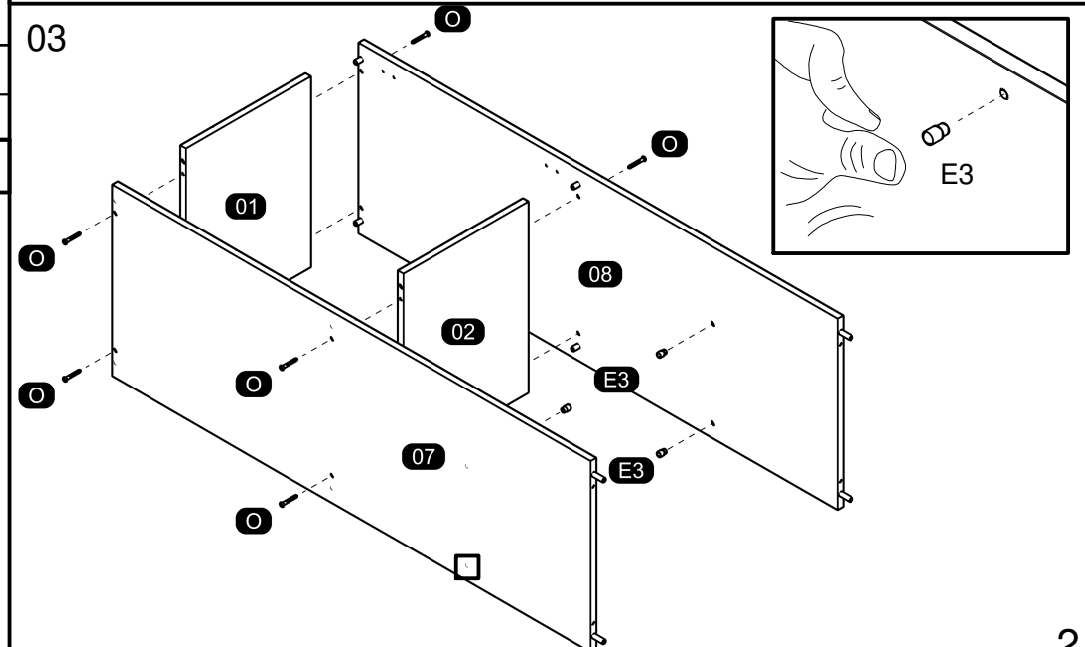

04

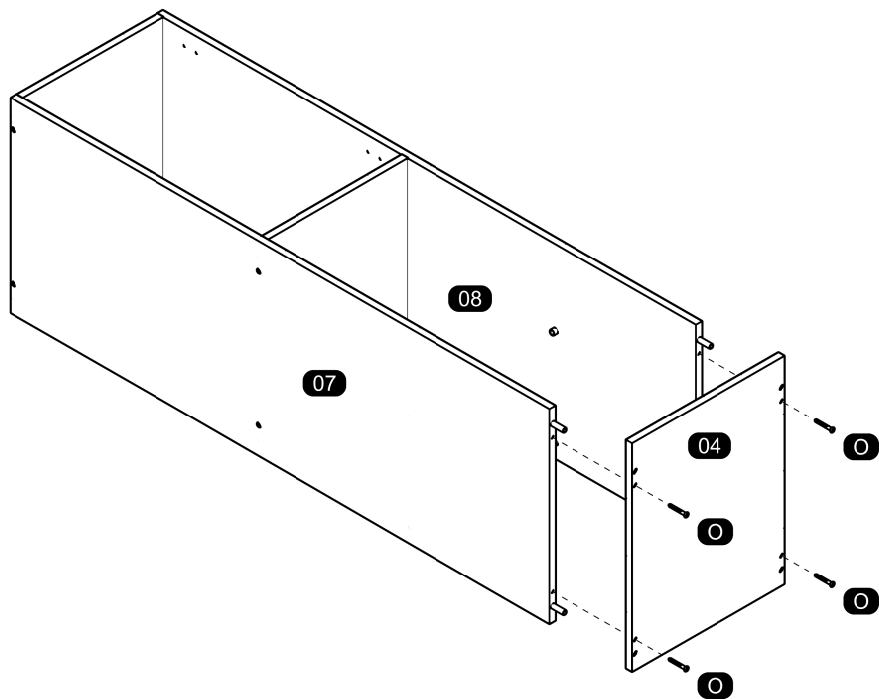

06

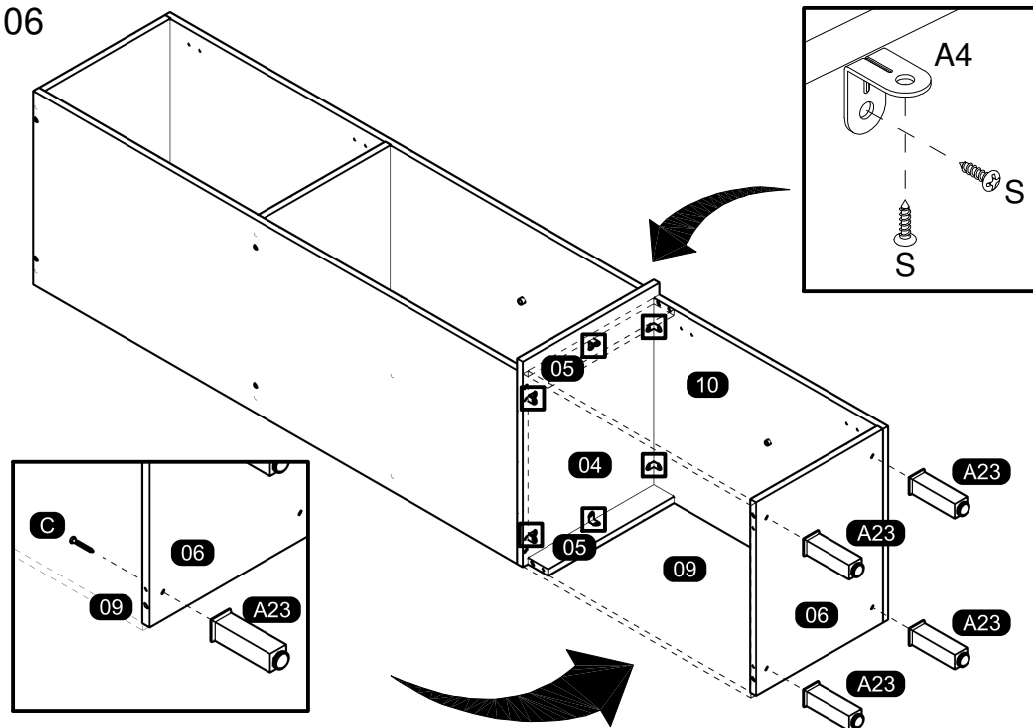

05

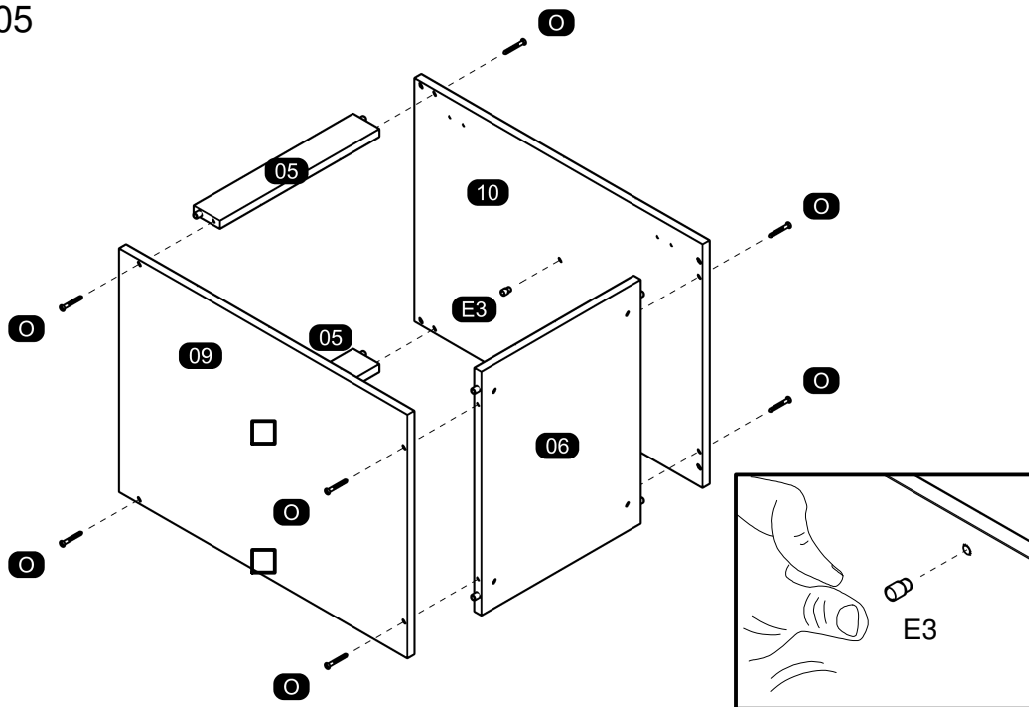

07

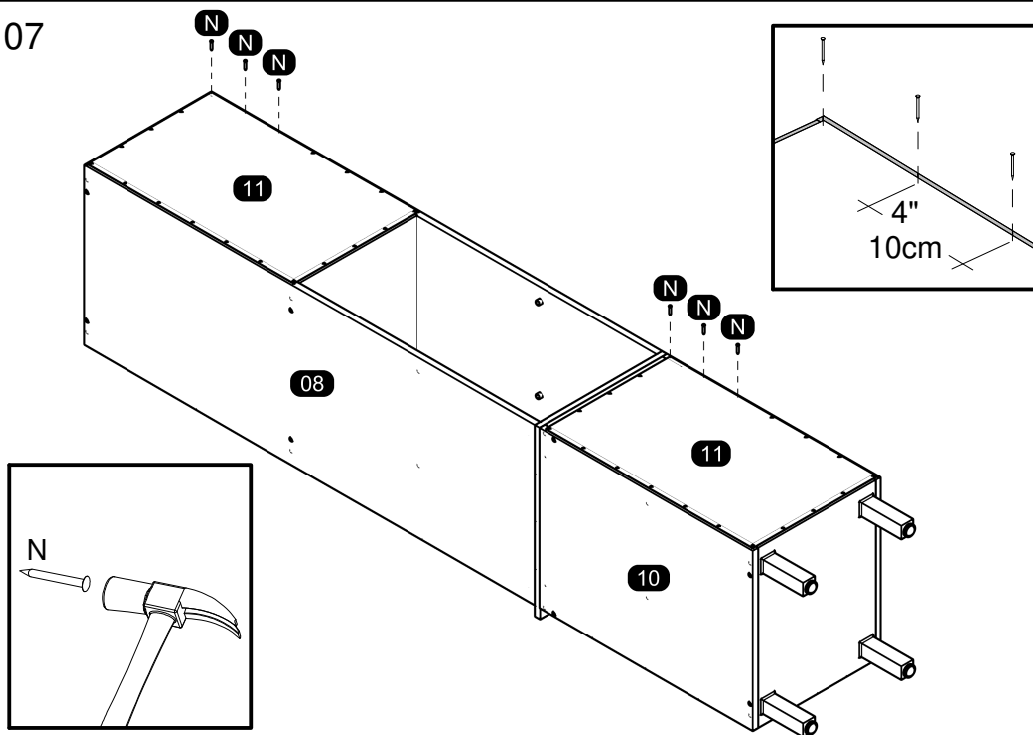

08

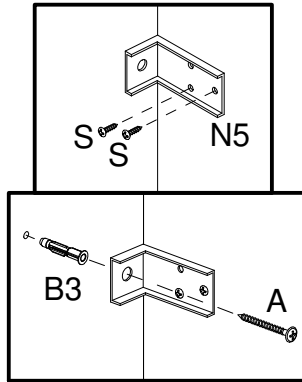
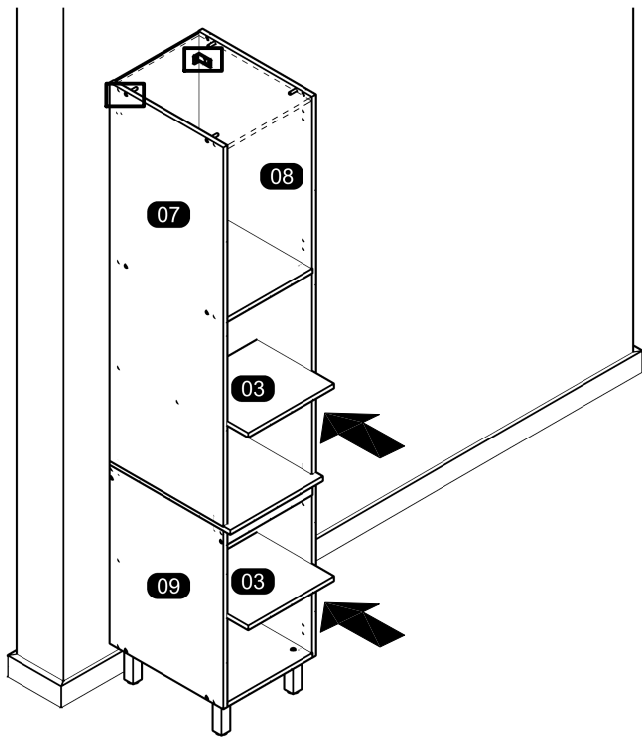

DOOR MOUNTING RIGHT SIDE
MONTAGEM DA PORTA LADO DIREITO
MONTAJE DE LA PUERTA LADO DERECHO

10

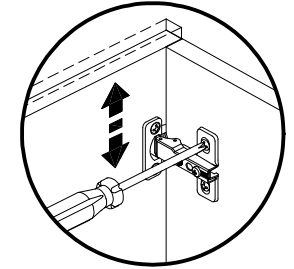
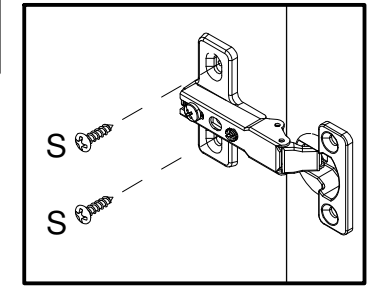
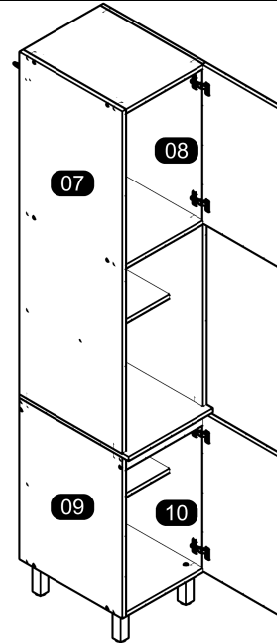

Vertical Adjustment
 Regulagem Vertical
 Ajuste Vertical

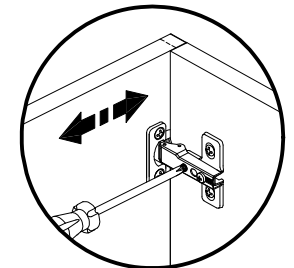

Horizontal Adjustment
 Regulagem Horizontal
 Ajuste Horizontal

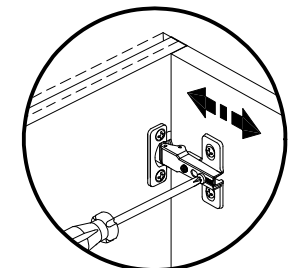

Depth Adjustment
 Regulagem Profundidade
 Ajuste Profundidad

MOUNTING ON THE CHOSEN DOOR MODEL
MONTAGEM NO MODELO DE PORTA ESCOLHIDO / MONTAJE EN EL MODELO DE PUERTA ELEGIDO

09

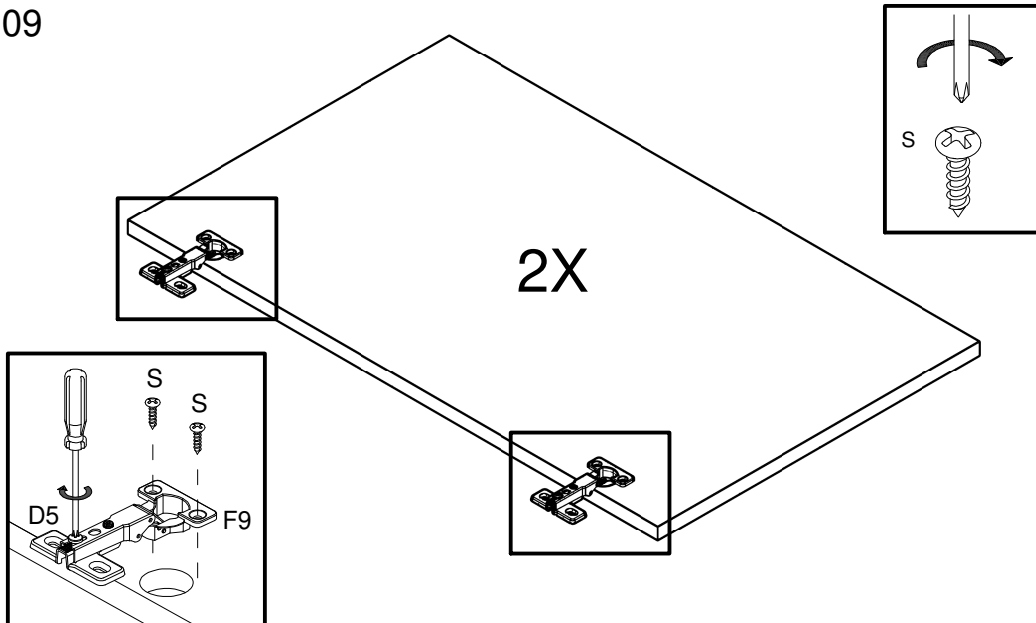

DOOR MOUNTING LEFT SIDE
MONTAGEM DA PORTA LADO ESQUERDO
MONTAJE DE LA PUERTA LADO IZQUIERDO

11

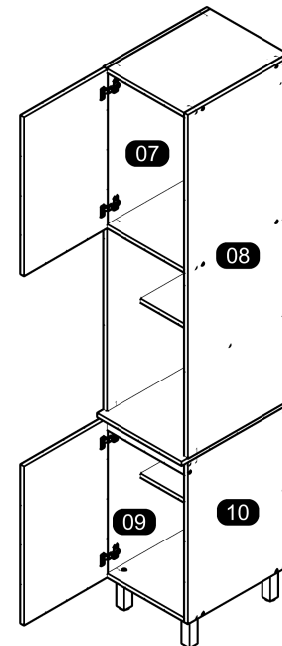

ASSEMBLY INSTRUCTIONS MANUAL DE MONTAGEM / INSTRUCCIONES DE ARMADO

AMARA 2 DOORS
PORTAS AMARA 2P
PUERTAS AMARA 2P

Reference | Revise
Referência | Revisão **00**
Referencia | Revisión

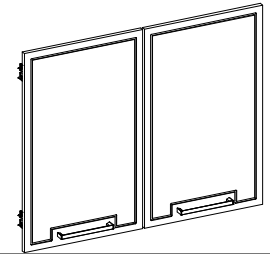

**YOU WILL NEED
VOCÊ VAI PRECISAR DE / USTED NECESITARÁ**

Tools not supplied
Ferramentas não fornecidas / Herramientas no incluidas

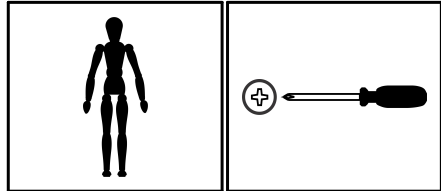

1 Person
1 Pessoa
1 Persona

Screwdriver Phillips
Chave Phillips
Destornillador cruz

**PARTS IDENTIFICATION
IDENTIFICAÇÃO DAS PEÇAS / IDENTIFICACIÓN DE LAS PIEZAS**

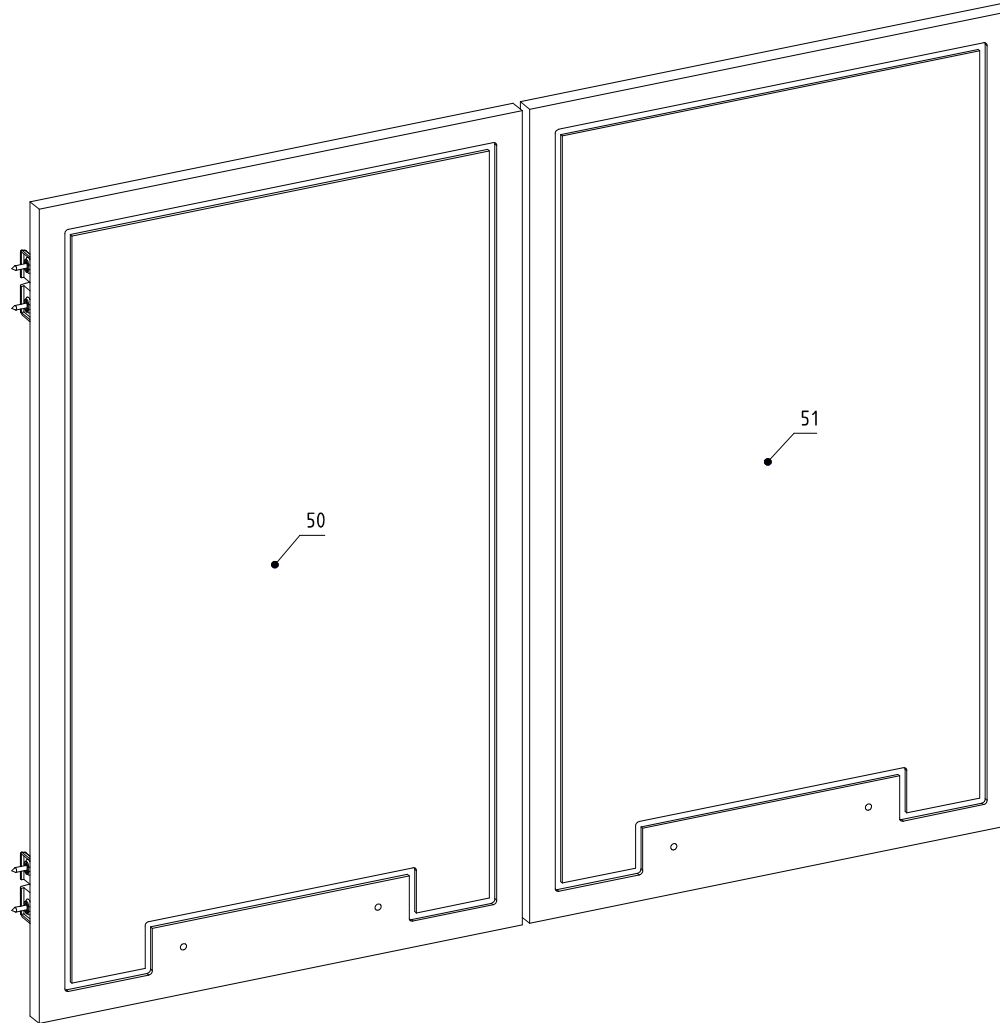

Nº	Measures_Inches	Medidas_cm	Qty./Qtd.
50	25 7/8 x 15 5/8 x 5/8	65.6 x 39.7 x 1.5	1
51	25 7/8 x 15 5/8 x 5/8	65.6 x 39.7 x 1.5	1



MAXIMUM RECOMMENDED WEIGHT
BEING THIS EVENLY DISTRIBUTED.

PESO MÁXIMO RECOMENDADO SENDO
ESTE DISTRIBUÍDO UNIFORMEMENTE.

PESO MÁXIMO RECOMENDADO SIENDO
ESTE UNIFORMEMENTE DISTRIBUIDO.

LB

KG

IDENTIFICATION OF ACCESSORIES IDENTIFICAÇÃO DOS ACESSÓRIOS/ IDENTIFICACIÓN DE ACCESORIOS



The separation of the accessories before you start the assembly will facilitate the same. In case of doubt on the size of the screws and bolts, use the ruler to bottom of page.
A separação dos acessórios antes de iniciar a montagem facilitará a mesma. Em caso de dúvida no tamanho dos parafusos e cavilhas, utilize a régua ao final da página.
La separación de los accesorios antes de comenzar el armado facilitará el mismo. En caso de duda sobre el tamaño de los tornillos y taquetes, utilice la regla al pie de página.

K27		Handle Puxador Aleno Fit / Tirador	160 mm	2
T		Flanged head screw Parafuso flangeado / Tornillo de cabeza flangeada	3,5x25 mm	4



PRE-ASSEMBLY PRÉ-MONTAGEM / PRE ARMADO

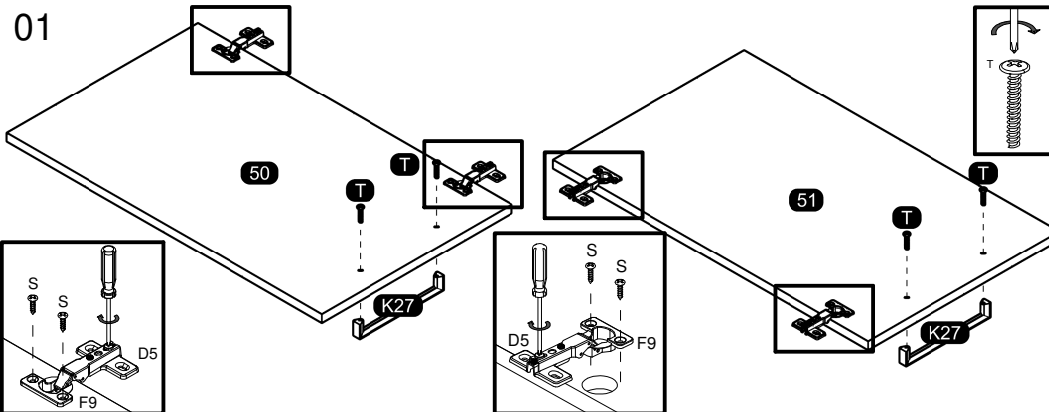

ASSEMBLY MONTAGEM / ARMADO

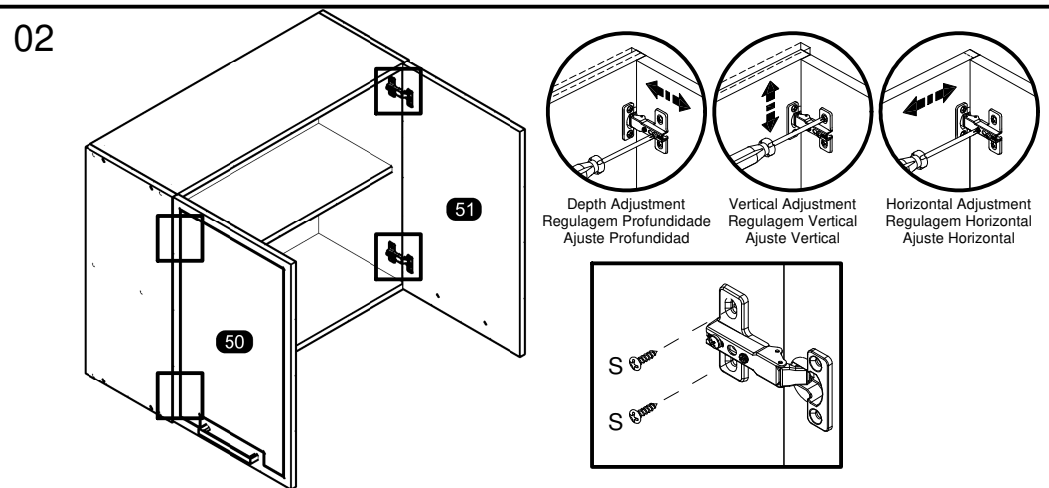

03

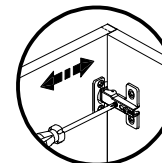
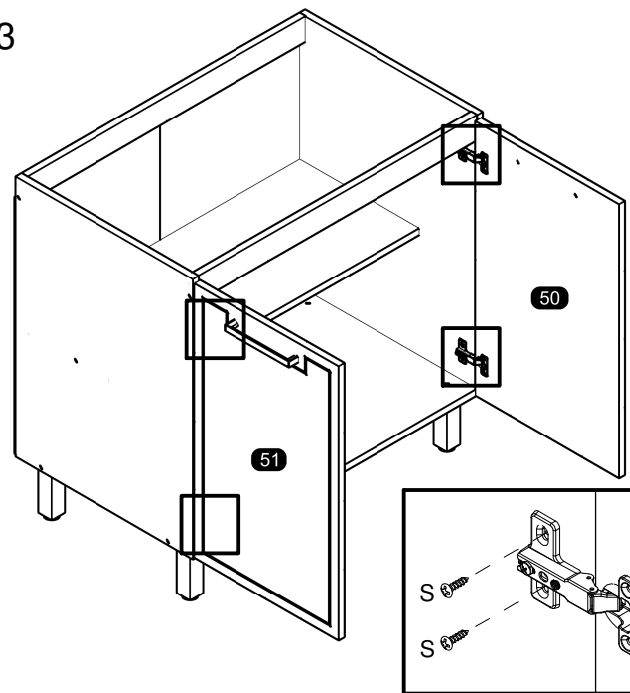

Horizontal Adjustment
Regulagem Horizontal
Ajuste Horizontal

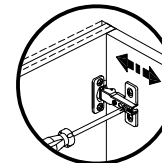

Depth Adjustment
Regulagem Profundidade
Ajuste Profundidade

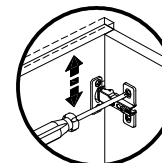

Vertical Adjustment
Regulagem Vertical
Ajuste Vertical

04

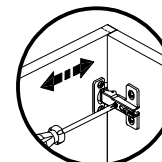
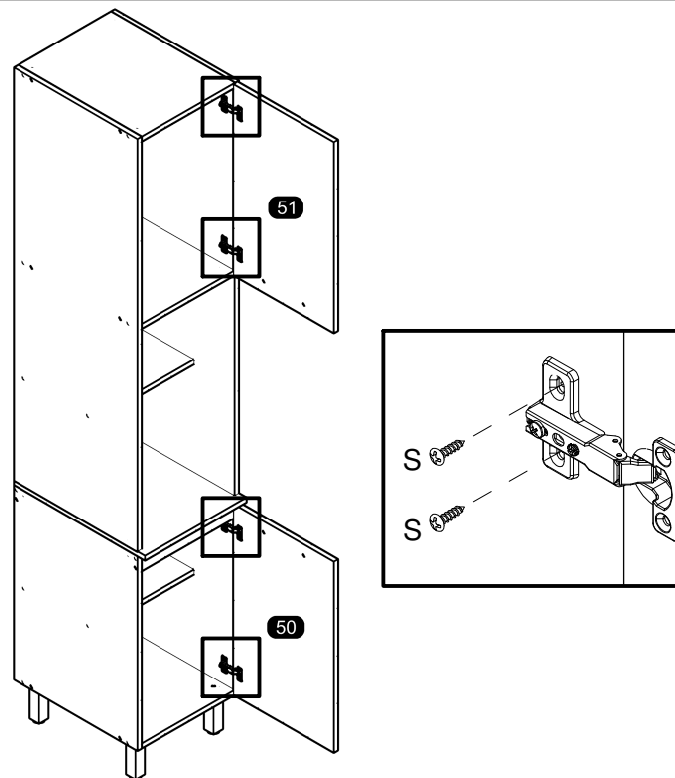

Horizontal Adjustment
Regulagem Horizontal
Ajuste Horizontal

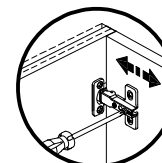

Depth Adjustment
Regulagem Profundidade
Ajuste Profundidade

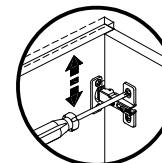

Vertical Adjustment
Regulagem Vertical
Ajuste Vertical

ASSEMBLY INSTRUCTIONS MANUAL DE MONTAGEM / INSTRUCCIONES DE ARMADO

AMARA DOORS OVENS TOWER
PORTAS AMARA TORRE DE FORNOS
PUERTAS AMARA TORRE DE HORNOS

Reference | Revise
Referência | Revisão
Referencia | Revisión

240556

00

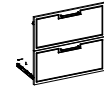

YOU WILL NEED
VOCÊ VAI PRECISAR DE / USTED NECESITARÁ

Tools not supplied
Ferramentas não fornecidas / Herramientas no incluidas

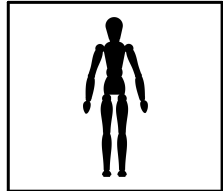

1 Person
1 Pessoa
1 Persona

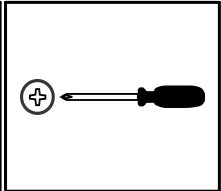

Screwdriver Phillips
Chave Phillips
Destornillador cruz

PARTS IDENTIFICATION
IDENTIFICAÇÃO DAS PEÇAS / IDENTIFICACIÓN DE LAS PIEZAS

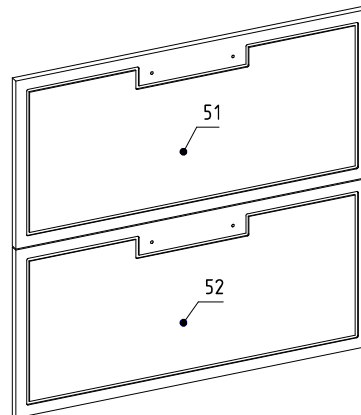
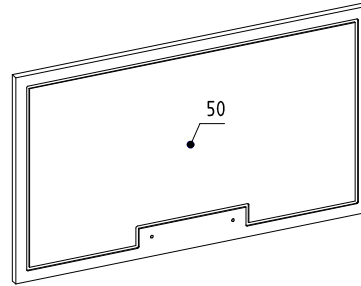

Nº	Measures_Inches	Medidas_cm	Qty./Qtd.
50	27 3/8 x 15 3/4 x 5/8	69.6 x 39.9 x 1.5	1
51	27 3/8 x 12 3/4 x 5/8	69.6 x 32.5 x 1.5	1
52	27 3/8 x 12 3/4 x 5/8	69.6 x 32.5 x 1.5	1



MAXIMUM RECOMMENDED WEIGHT
BEING THIS EVENLY DISTRIBUTED.

PESO MÁXIMO RECOMENDADO SENDO
ESTE DISTRIBUÍDO UNIFORMEMENTE.

PESO MÁXIMO RECOMENDADO SIENDO
ESTE UNIFORMEMENTE DISTRIBUIDO.

—	LB	KG
---	----	----

IDENTIFICATION OF ACCESSORIES IDENTIFICAÇÃO DOS ACESSÓRIOS/ IDENTIFICACIÓN DE ACCESORIOS



The separation of the accessories before you start the assembly will facilitate the same. In case of doubt on the size of the screws and bolts, use the ruler at the bottom of the page.
 A separação dos acessórios antes de iniciar a montagem facilitará a mesma. Em caso de dúvida no tamanho dos parafusos e cavilhas, utilize a régua ao final da página.
 La separación de los accesorios antes de comenzar el armado facilitará el mismo. En caso de duda sobre el tamaño de los tornillos y taquetes, utilice la regla al pie de página.

K27		Handle Puxador Aleno Fit / Tirador	160 mm	3
T		Flanged head screw Parafuso flangeado / Tornillo de cabeza flangeada	3,5x25 mm	6



PRE-ASSEMBLE PRÉ-MONTAGEM / PRE ARMADO

01

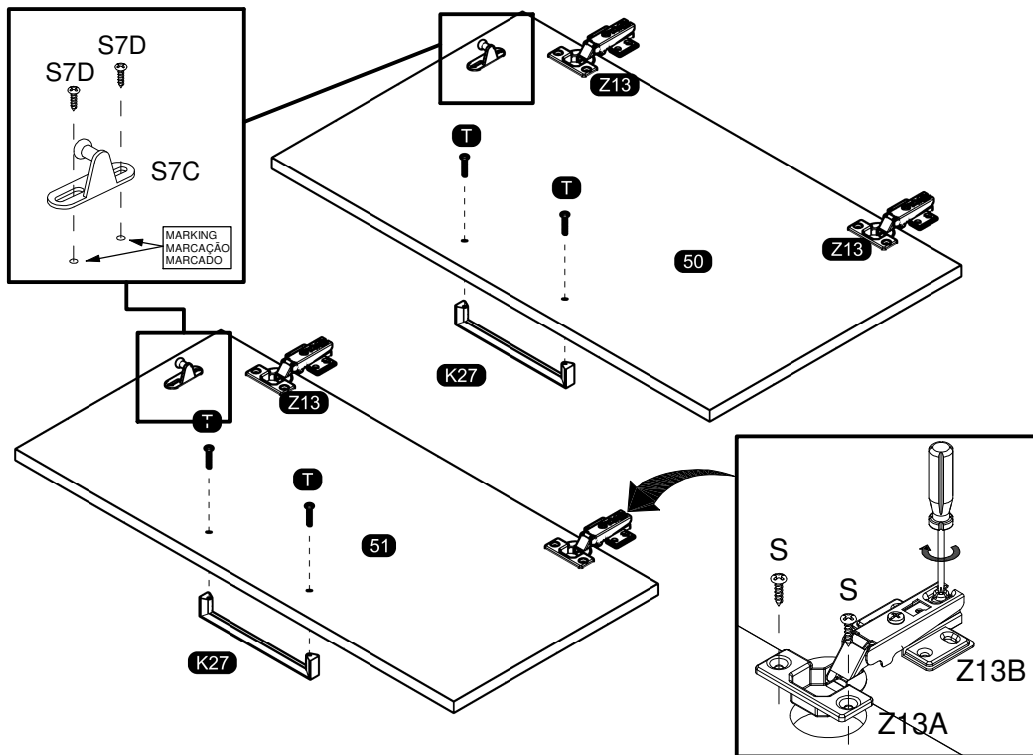

02

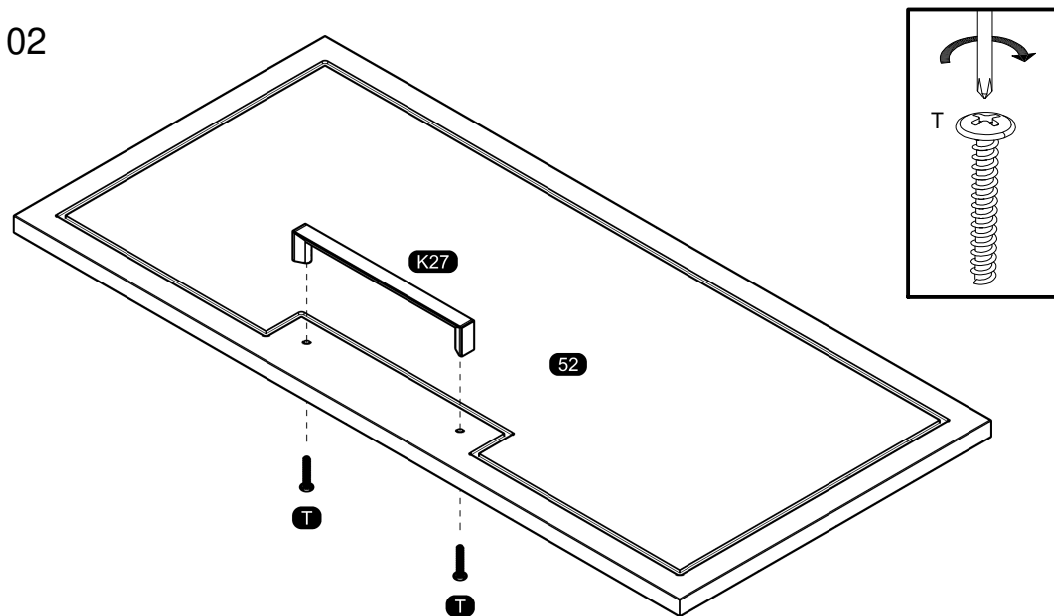

ASSEMBLY MONTAGEM / ARMADO

03

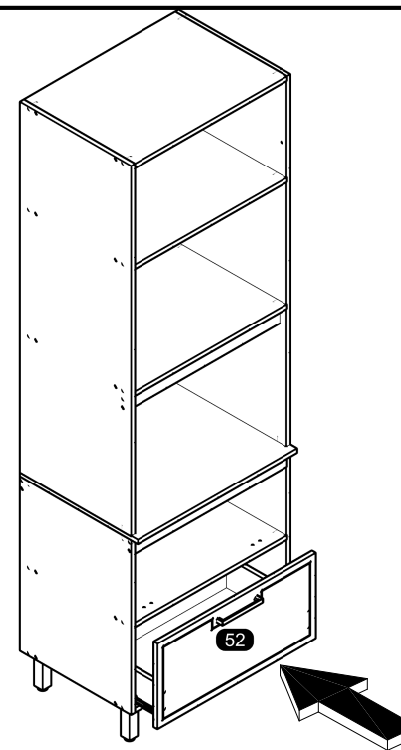

Drawer insertion
Inserção de gaveta
Inserción del cajón

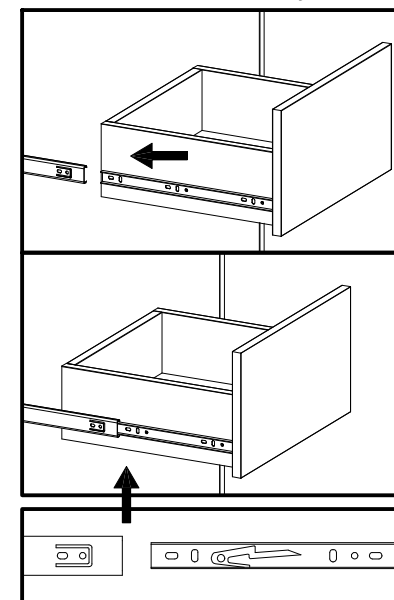

04

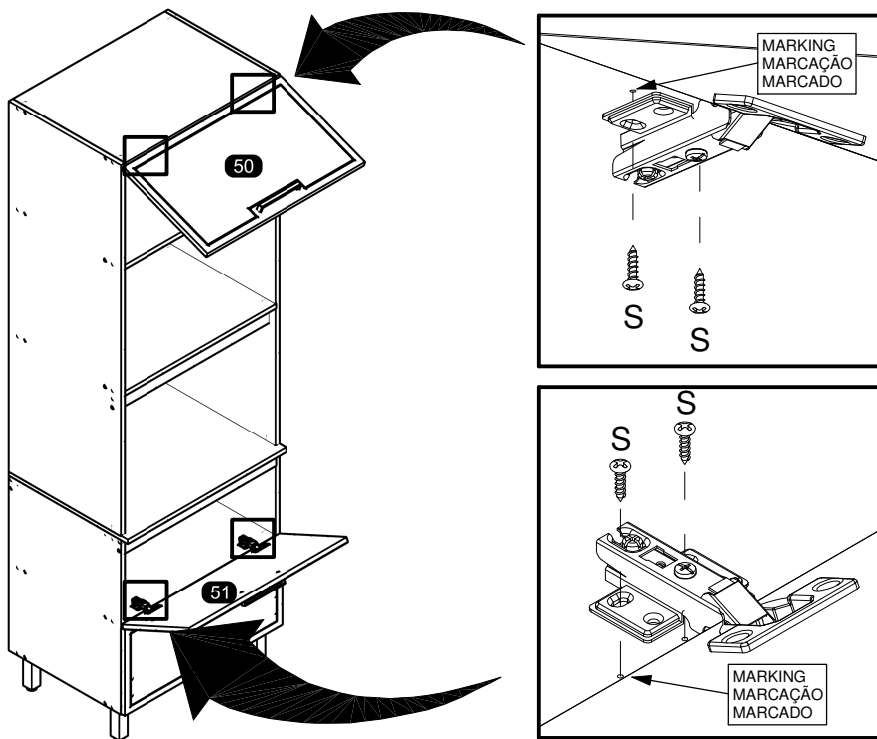

06

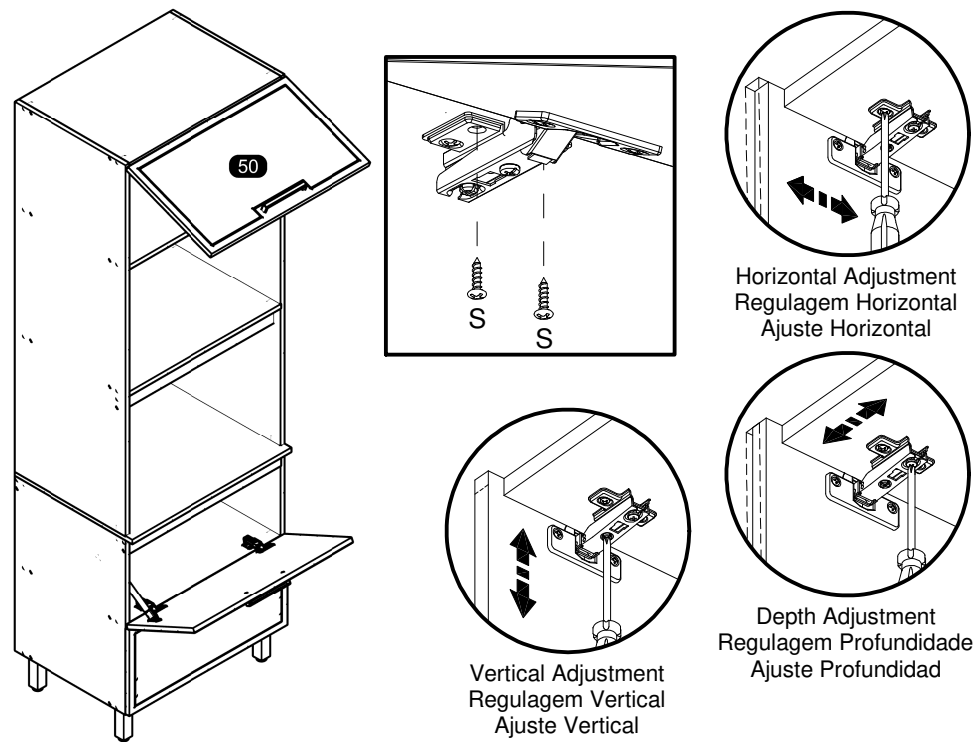

05

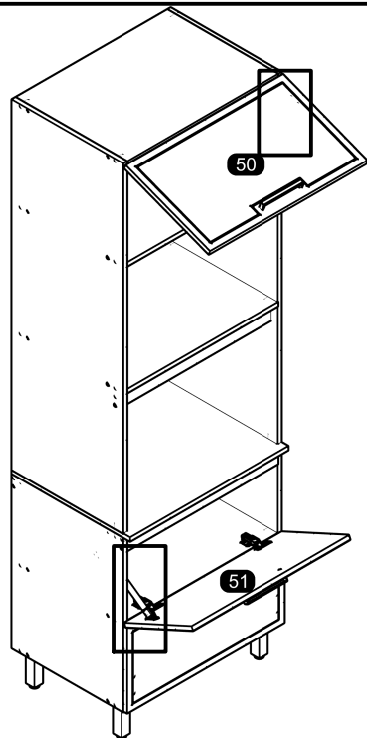

Follow the instruction corresponding to the template you received.
Siga a instrução correspondente ao modelo que recebeu.
Siga las instrucciones correspondientes al modelo que recibió.

Model 1 / Modelo 1

Model 2 / Modelo 2

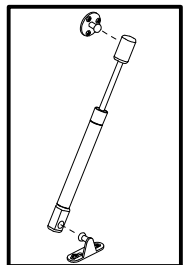
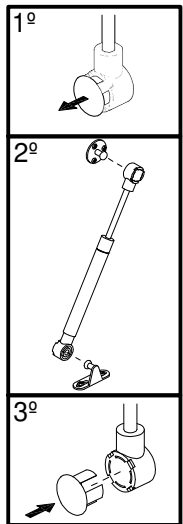

07

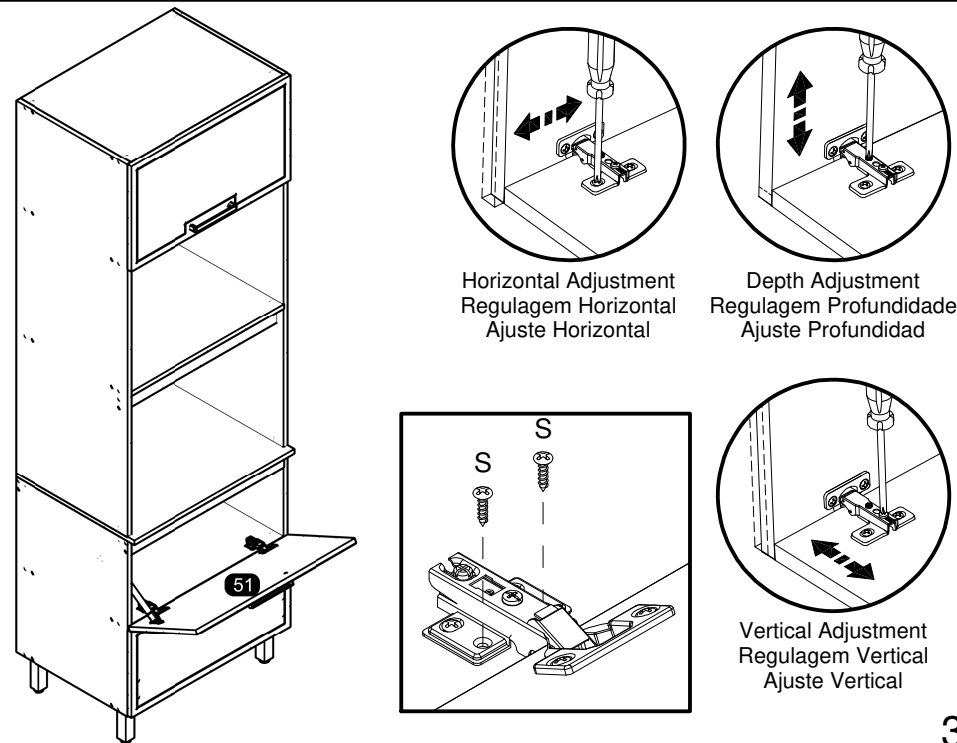

ASSEMBLY INSTRUCTIONS MANUAL DE MONTAGEM / INSTRUCCIONES DE ARMADO

TOP 31 1/2"
TAMPO DE COZINHA 800MM
TAMPA 800MM

Reference
Referência
Referencia **240791** | Revise
Revisão
Revisión **00**

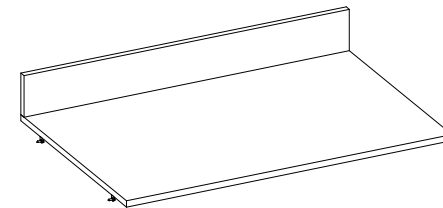

**YOU WILL NEED
VOCÊ VAI PRECISAR DE / USTED NECESITARÁ**

**PARTS IDENTIFICATION
IDENTIFICAÇÃO DAS PEÇAS / IDENTIFICACIÓN DE LAS PIEZAS**

Tools not supplied
Ferramentas não fornecidas / Herramientas no incluidas

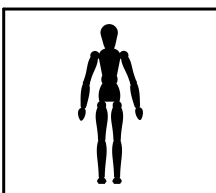

1 Person
1 Pessoa
1 Persona

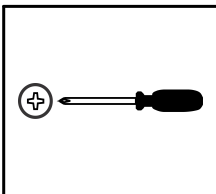

Screwdriver Phillips
Chave Phillips
Destornillador cruz

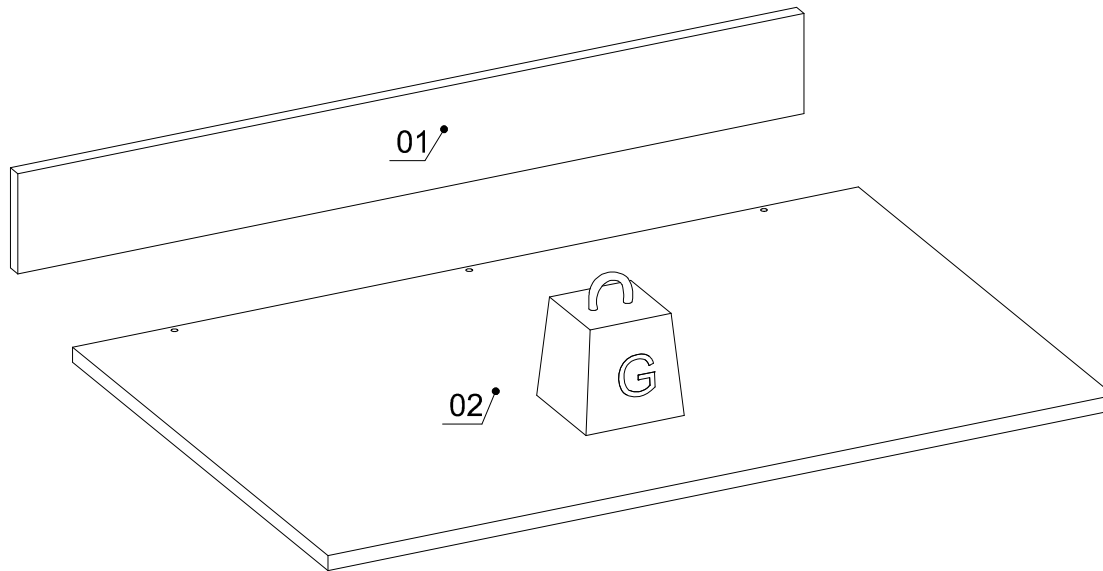

Nº	Measures_Inches	Medidas_cm	Qty./Qtd.
01	31 1/2 x 3 7/8 x 5/8	80.0 x 10.0 x 1.5	1
02	31 1/2 x 20 1/2 x 5/8	80.0 x 52.0 x 1.5	1



MAXIMUM RECOMMENDED WEIGHT
BEING THIS EVENLY DISTRIBUTED.

PESO MÁXIMO RECOMENDADO SENDO
ESTE DISTRIBUÍDO UNIFORMEMENTE.



PESO MÁXIMO RECOMENDADO SIENDO
ESTE UNIFORMEMENTE DISTRIBUIDO.

	LB	KG
G	33	15

IDENTIFICATION OF ACCESSORIES IDENTIFICAÇÃO DOS ACESSÓRIOS/ IDENTIFICACIÓN DE ACCESORIOS



The separation of the accessories before you start the assembly will facilitate the same. In case of doubt on the size of the screws and bolts, use the ruler to bottom of page.
 A separação dos acessórios antes de iniciar a montagem facilitará a mesma. Em caso de dúvida no tamanho dos parafusos e cavilhas, utilize a régua ao final da página.
 La separación de los accesorios antes de comenzar el armado facilitará el mismo. En caso de duda sobre el tamaño de los tornillos y taquetes, utilice la regla al pie de página.

D		Flat head screw Parafuso chato / Tornillo de cabeza plana	4,0x40 mm	3
S		Pan head screw Parafuso panela / Tornillo de pan	3,5x14 mm	8
Y18		Zamac bracket Cantoneira zamac/ Suporte de zamac	13x13 mm	4

ASSEMBLY MONTAGEM / ARMADO

01

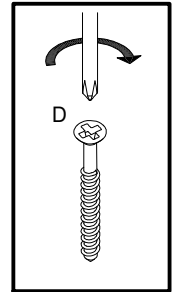
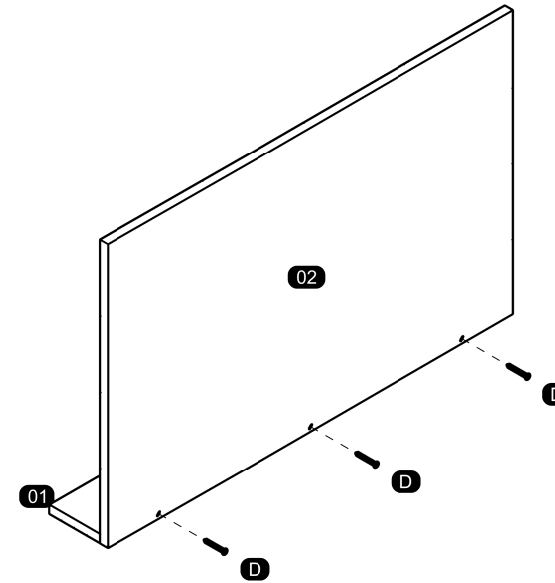

02

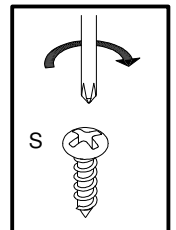
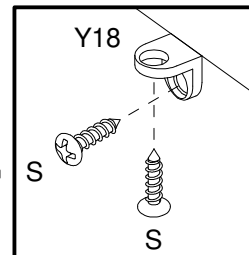
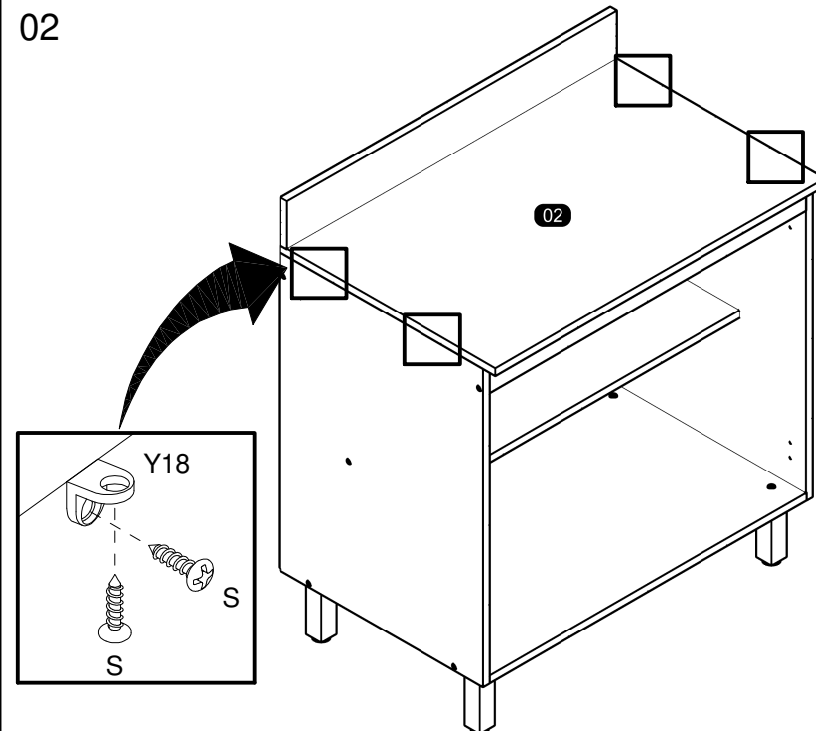

ASSEMBLY INSTRUCTIONS MANUAL DE MONTAGEM / INSTRUCCIONES DE ARMADO

2-DOOR GLASS WALL CABINET
AEREO 2 PORTAS DE VIDRO
GABINETE DE PARED CON 2 PUERTAS DE VIDRO

Reference
Referência
Referencia **250306** | Revise
Revisão
Revisión **00**

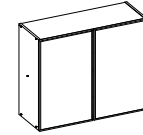

**YOU WILL NEED
VOCÊ VAI PRECISAR DE / USTED NECESITARÁ**

Tools not supplied
Ferramentas não fornecidas / Herramientas no incluidas

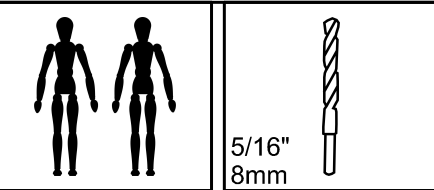

2 People
2 Pessoas
2 Personas

Drill bit
Broca
Taladro

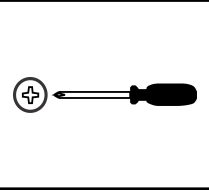

Screwdriver Phillips
Chave Phillips
Destornillador cruz

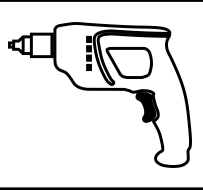

Drill machine
Furadeira
Taladro



Hammer
Martelo
Martillo

 MAXIMUM RECOMMENDED WEIGHT BEING THIS EVENLY DISTRIBUTED.
PESO MÁXIMO RECOMENDADO SENDO ESTE DISTRIBUÍDO UNIFORMEMENTE.
PESO MÁXIMO RECOMENDADO SIENDO ESTE UNIFORMEMENTE DISTRIBUIDO.

—	LB	KG
F	22	10

**PARTS IDENTIFICATION
IDENTIFICAÇÃO DAS PEÇAS / IDENTIFICACIÓN DE LAS PIEZAS**

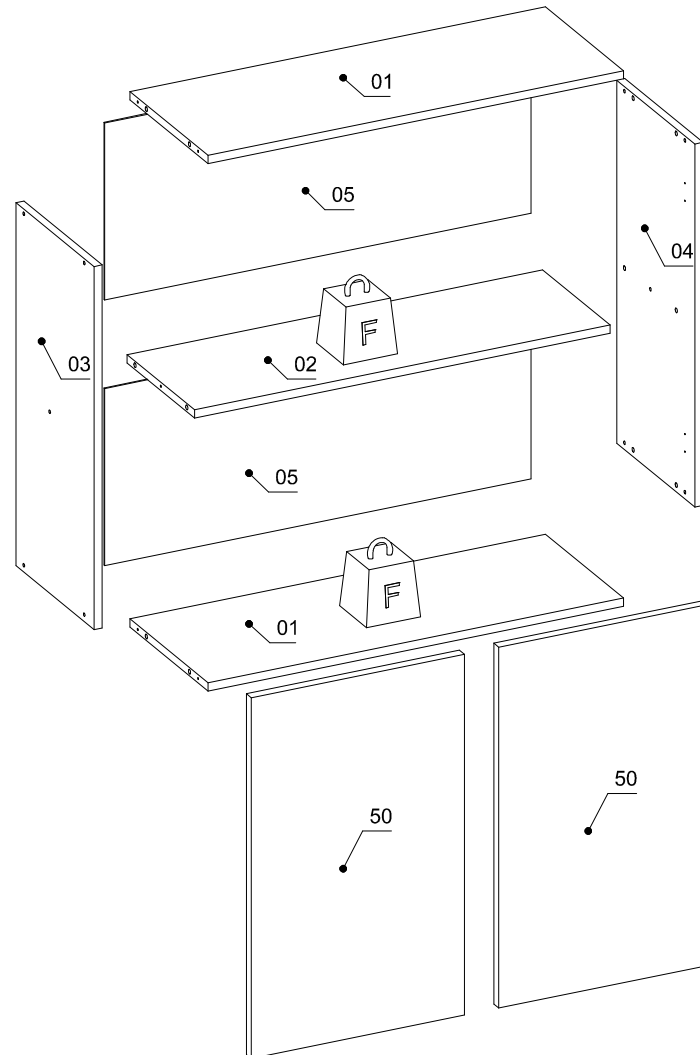

Nº	Measures_Inches	Medidas_cm	Qty./Qtd.
01	30 3/8 x 11 3/8 x 5/8	77.0 x 29.0 x 1.5	2
02	30 3/8 x 9 7/8 x 5/8	77.0 x 25.0 x 1.5	1
03	26 x 11 3/8 x 5/8	66.0 x 29.0 x 1.5	1
04	26 x 11 3/8 x 5/8	66.0 x 29.0 x 1.5	1
05	31 1/8 x 12 5/8 x 1/8	79.0 x 32.2 x 0.3	2
50	25 7/8 x 15 1/2 x 3/4	65.6 x 39.5 x 1.8	2

IDENTIFICATION OF ACCESSORIES IDENTIFICAÇÃO DOS ACESSÓRIOS/ IDENTIFICACIÓN DE ACCESORIOS



The separation of the accessories before you start the assembly will facilitate the same. In case of doubt on the size of the screws and bolts, use the ruler at the bottom of the page.
A separação dos acessórios antes de iniciar a montagem facilitará a mesma. Em caso de dúvida no tamanho dos parafusos e cavilhas, utilize a régua ao final da página.
La separación de los accesorios antes de comenzar el armado facilitará el mismo. En caso de duda sobre el tamaño de los tornillos y taquetes, utilice la regla al pie de página.

A		Flanged head screw Parafuso flangeado / Tornillo de cabeza flangeada	5,0x60 mm	2
B3		Bushing Bucha expansiva / Tapón	8x50 mm	2
C1		Metal claw Garra de metal / Garra metal	-	4
D5		Hinge shim Calço dobradiça / Bisagra de calce	-	4
E		Wooden dowel Cavilha / Taquete	8x30 mm	12
F9		Metal hinge straight Dobradiça reta / Bisagra recta	26 mm	4
N		Nail Prego / Clavo	10x10	36
N5		Support "L" Suporte "L" / Soporte "L"	-	2
O		Flat head screw Parafuso chato / Tornillo de cabeza plana	4,5x45 mm	10
S		Pan head screw Parafuso panela / Tornillo de pan	3,5x14 mm	20

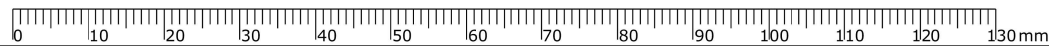

PRE-ASSEMBLE PRÉ-MONTAGEM / PRE ARMADO

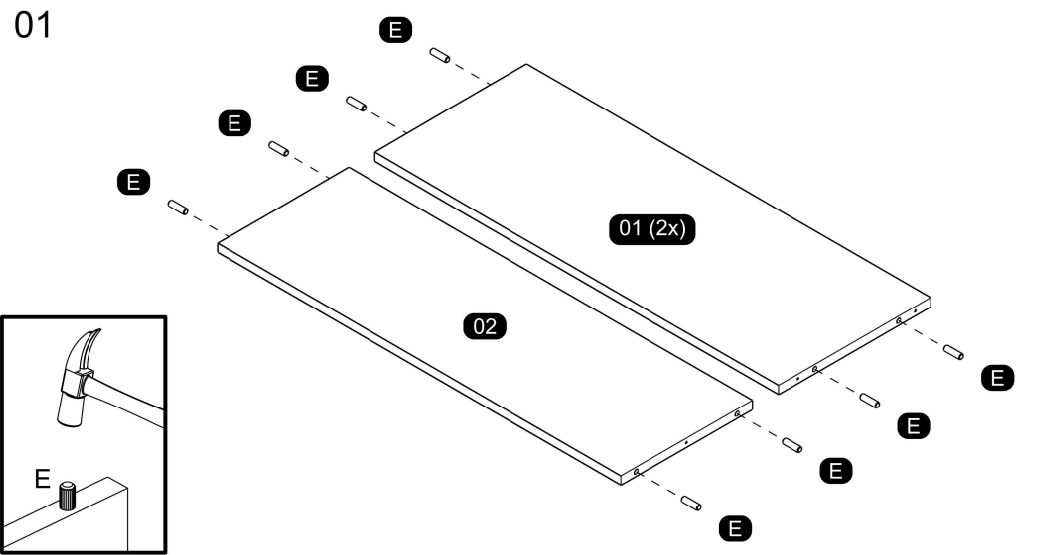

02

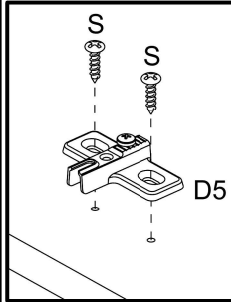
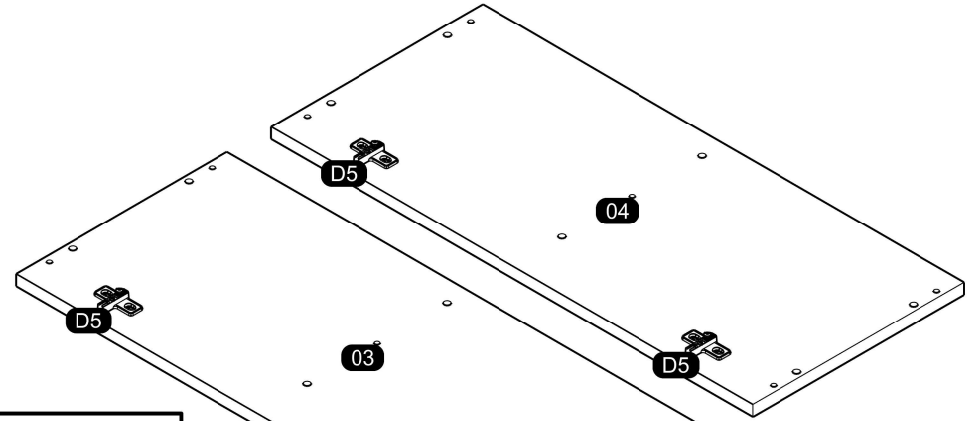

03

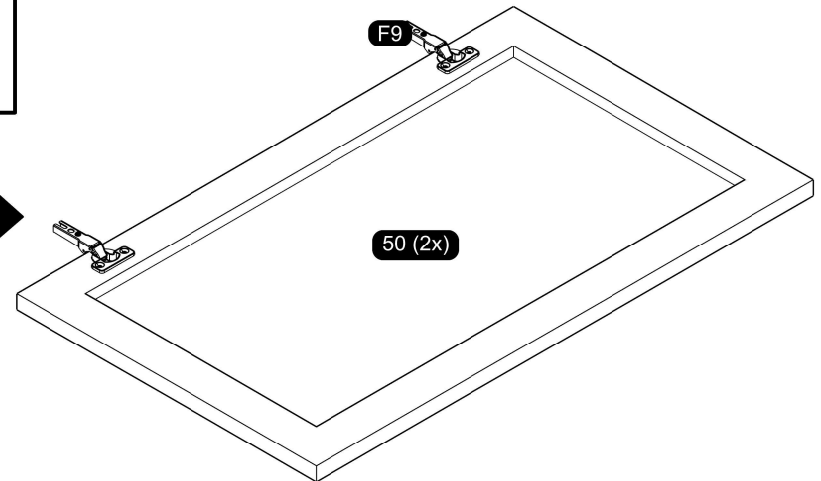
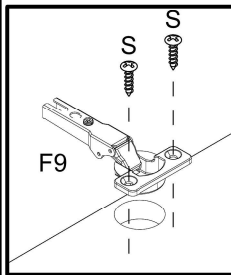

ASSEMBLY MONTAGEM / ARMADO

04

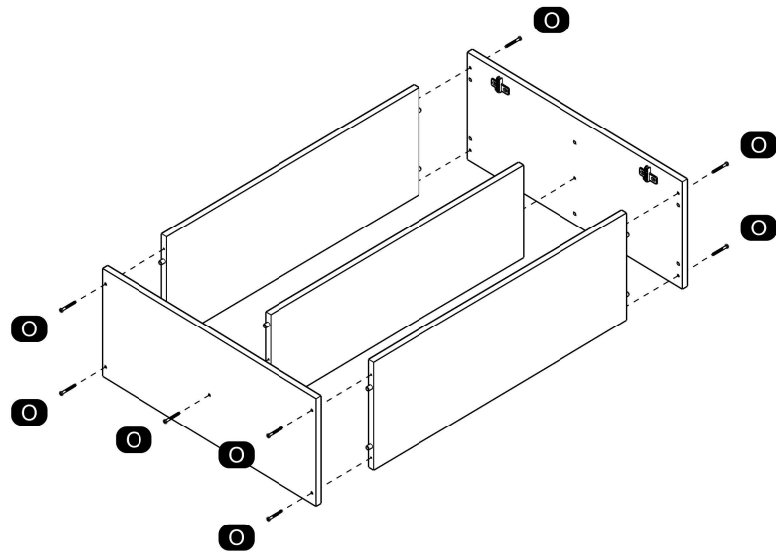
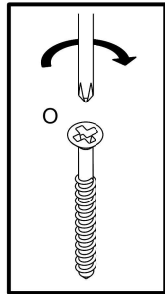

06

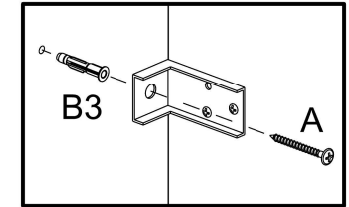
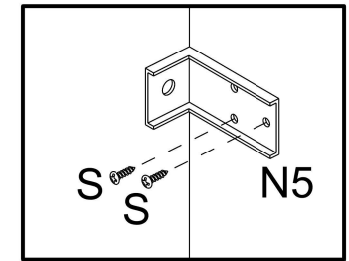
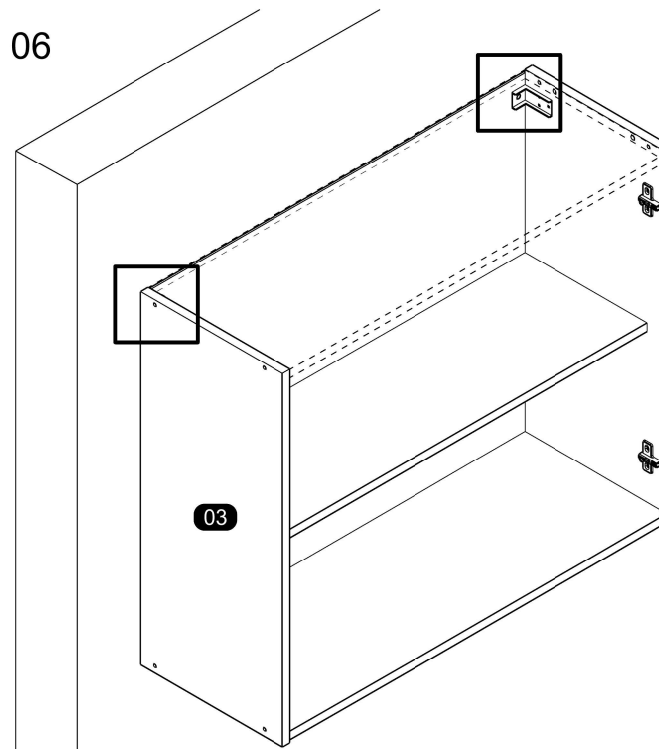

05

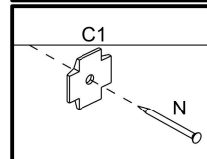
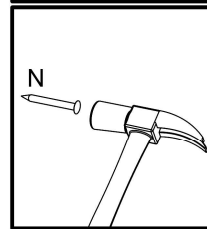
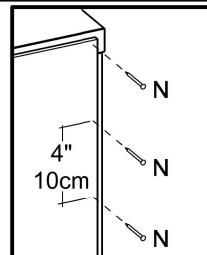
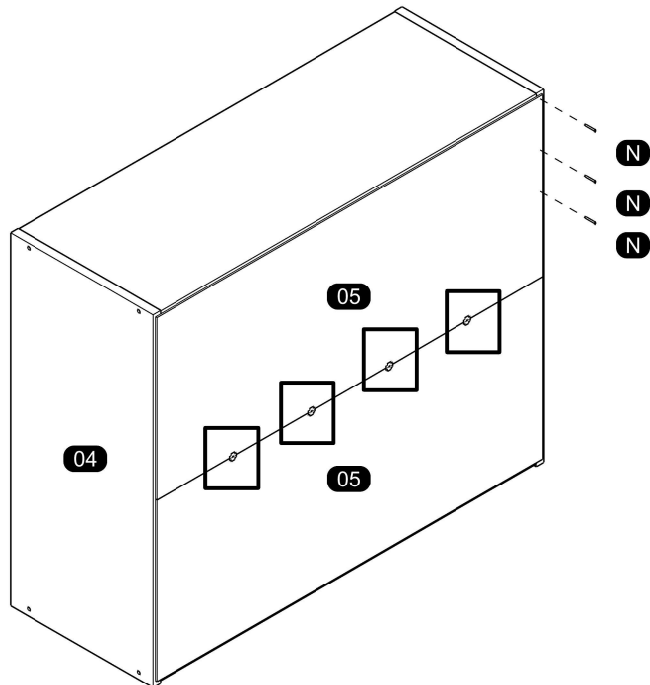

07

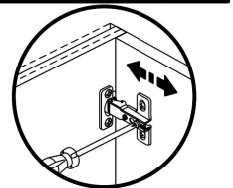
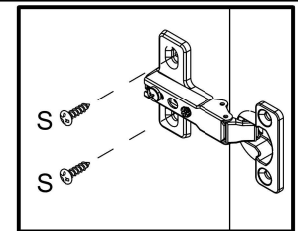
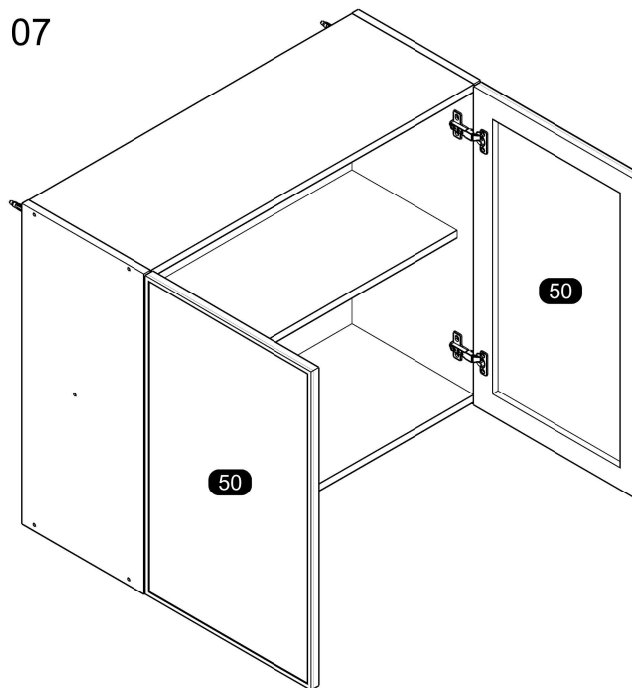

Depth Adjustment
Regulagem Profundidade
Ajuste Profundidade

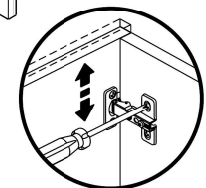

Vertical Adjustment
Regulagem Vertical
Ajuste Vertical

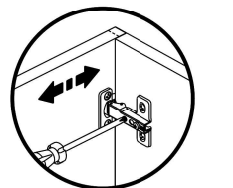

Horizontal Adjustment
Regulagem Horizontal
Ajuste Horizontal

ASSEMBLY INSTRUCTIONS MANUAL DE MONTAGEM / INSTRUCCIONES DE ARMADO

2 DOORS BASE CABINET
BALCAO 2 PORTAS
BALCÓN 2 PUERTAS

Reference
Referência
Referencia **240501** | Revise
Revisão
Revisión **00**

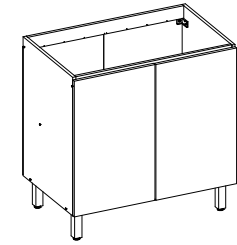

**YOU WILL NEED
VOCÊ VAI PRECISAR DE / USTED NECESITARÁ**

Tools not supplied
Ferramentas não fornecidas / Herramientas no incluidas

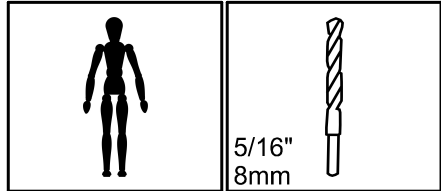

1 Person
1 Pessoa
1 Persona

Drill bit
Broca
Taladro

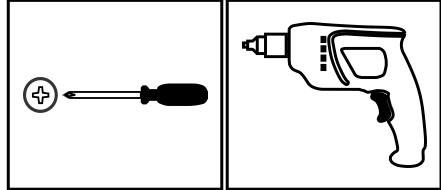

Screwdriver Phillips
Chave Phillips
Destornillador cruz

Drill machine
Furadeira
Taladro

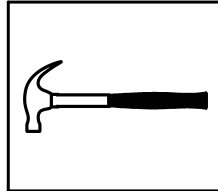

Hammer
Martelo
Martillo

**MAXIMUM RECOMMENDED WEIGHT
BEING THIS EVENLY DISTRIBUTED.**
**PESO MÁXIMO RECOMENDADO SENDO
ESTE DISTRIBUÍDO UNIFORMEMENTE.**
**PESO MÁXIMO RECOMENDADO SIENDO
ESTE UNIFORMEMENTE DISTRIBUIDO.**

	LB	KG
D	11	5
F	22	10

**PARTS IDENTIFICATION
IDENTIFICAÇÃO DAS PEÇAS / IDENTIFICACIÓN DE LAS PIEZAS**

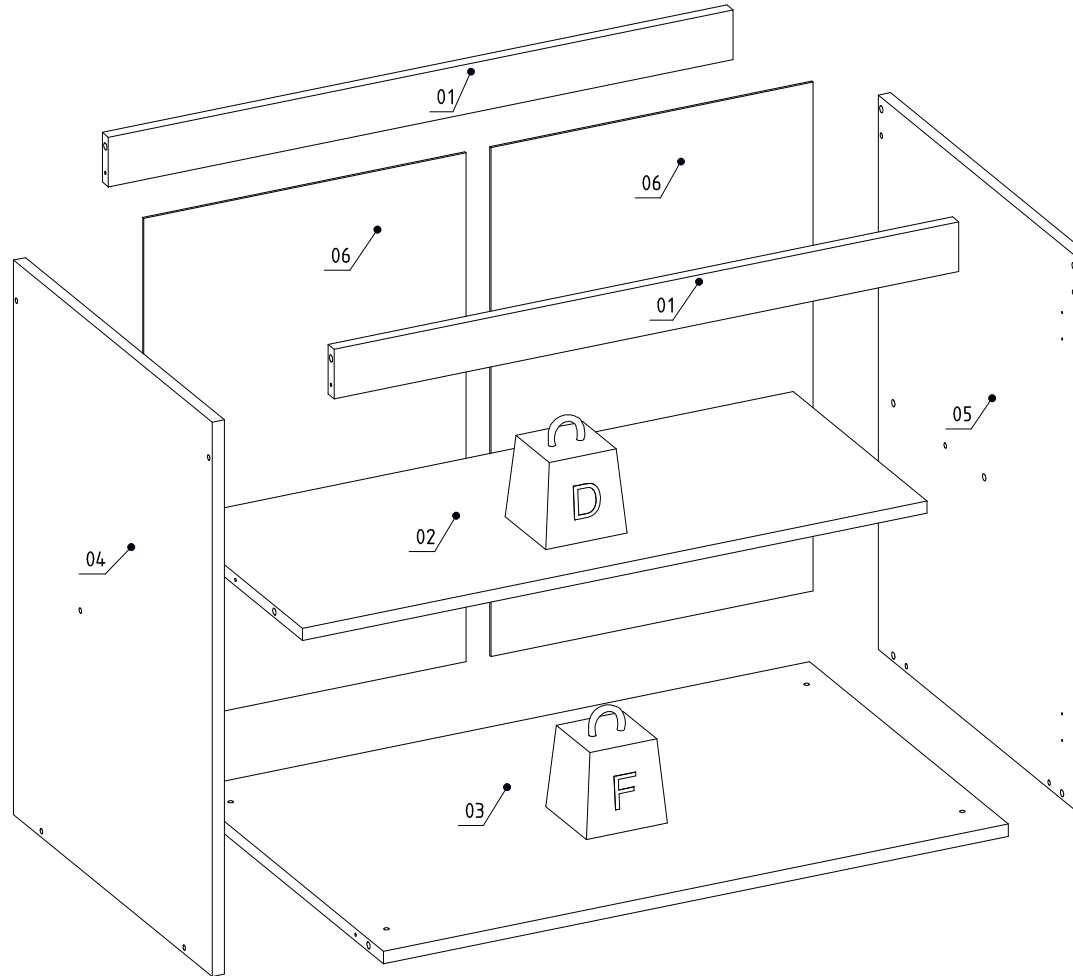

Nº	Measures_Inches	Medidas_cm	Qty./Qtd.
01	30 3/8 x 2 3/8 x 5/8	77.0 x 6.0 x 1.5	2
02	30 3/8 x 13 x 5/8	77.0 x 33.0 x 1.5	1
03	30 3/8 x 19 1/4 x 5/8	77.0 x 49.0 x 1.5	1
04	26 3/8 x 19 1/4 x 5/8	67.0 x 49.0 x 1.5	1
05	26 3/8 x 19 1/4 x 5/8	67.0 x 49.0 x 1.5	1
06	24 1/4 x 15 5/8 x 1/8	61.5 x 39.7 x 0.3	2

IDENTIFICATION OF ACCESSORIES IDENTIFICAÇÃO DOS ACESSÓRIOS/ IDENTIFICACIÓN DE ACCESORIOS



The separation of the accessories before you start the assembly will facilitate the same. In case of doubt on the size of the screws and bolts, use the ruler to bottom of page.
 A separação dos acessórios antes de iniciar a montagem facilitará a mesma. Em caso de dúvida no tamanho dos parafusos e cavilhas, utilize a régua ao final da página.
 La separación de los accesorios antes de comenzar el armado facilitará el mismo. En caso de duda sobre el tamaño de los tornillos y taquetes, utilice la regla al pie de página.

A		Flanged head screw Parafuso flangeado / Tornillo de cabeza flangeada	5,0x60 mm	2
A23		Foot Pé Quadrado FP / Pie	140 mm	4
B3		Bushing Bucha expansiva / Tapón	8x50 mm	2
C		Flanged head screw Parafuso flangeado / Tornillo de cabeza flangeada	4,5x45 mm	4
C1		Metal claw Garra de metal / Garra metal	-	1
D5		Hinge shim Calço dobradiça / Bisagra de calce	-	4
E		Wooden dowel Cavilha / Taquete	8x30 mm	12
F9		Metal hinge straight Dobradiça reta / Bisagra recta	26 mm	4
N		Nail Prego / Clavo	10x10	31
N5		Support "L" Suporte "L" / Soporte "L"	-	2
O		Flat head screw Parafuso chato / Tornillo de cabeza plana	4,5x45 mm	10
S		Pan head screw Parafuso panela / Tornillo de pan	3,5x14 mm	20



PRE-ASSEMBLE PRÉ-MONTAGEM / PRE ARMADO

01

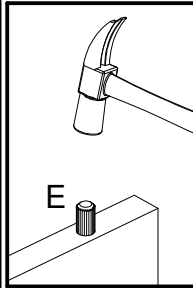
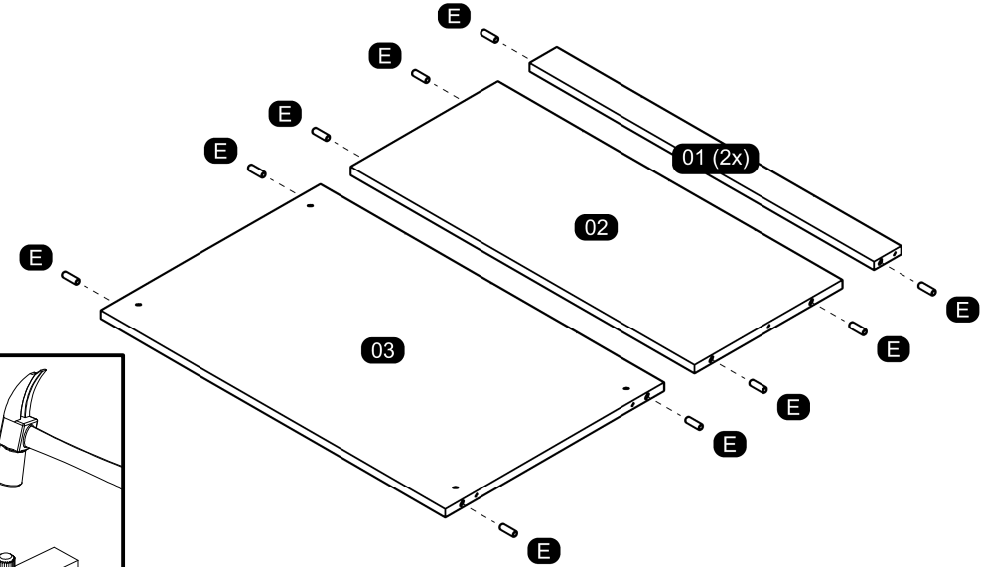

ASSEMBLY MONTAGEM / ARMADO

02

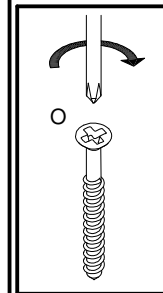
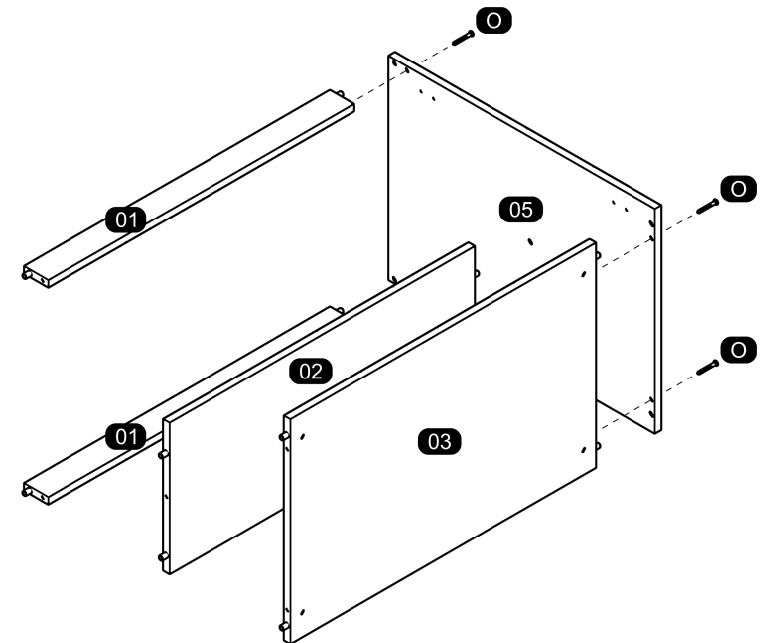

03

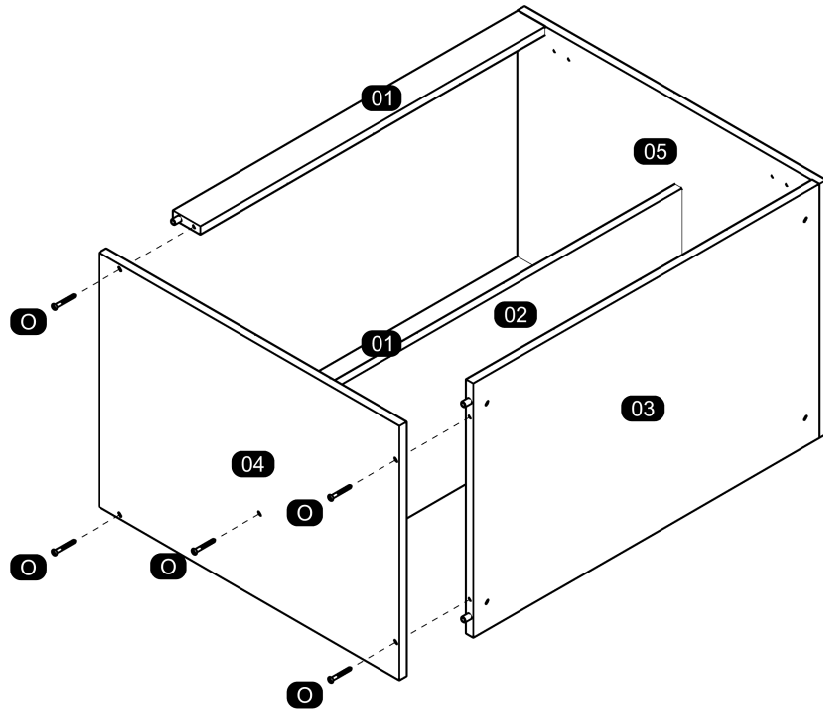

05

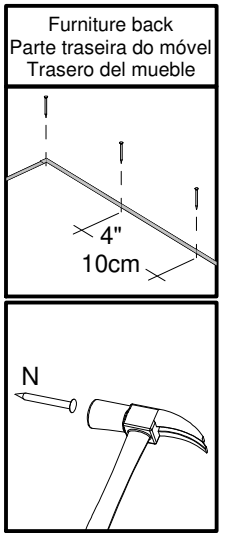
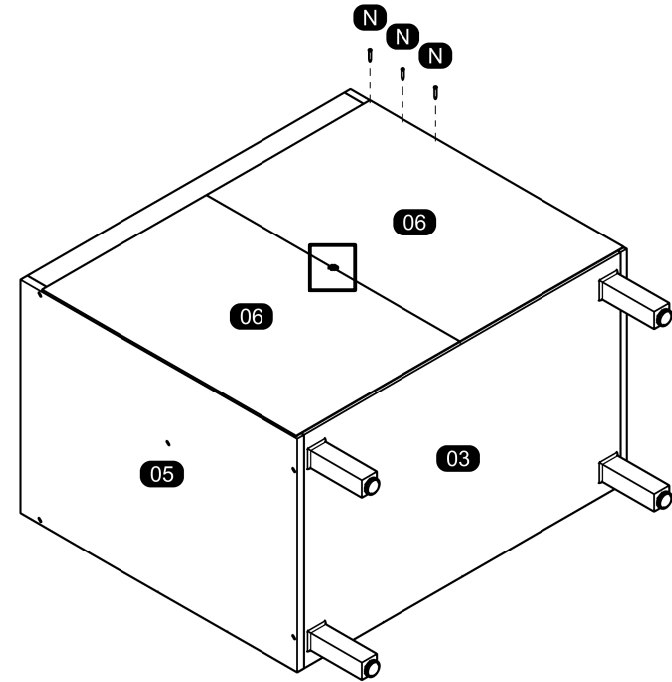
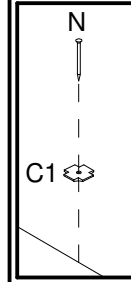

04

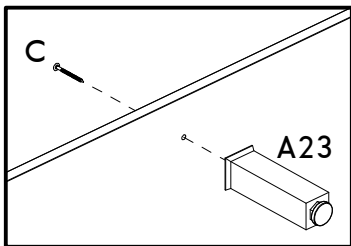
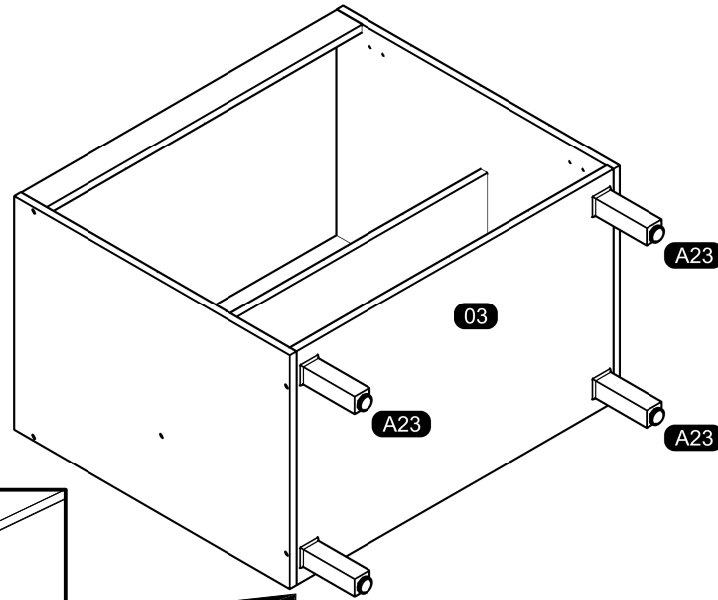

06

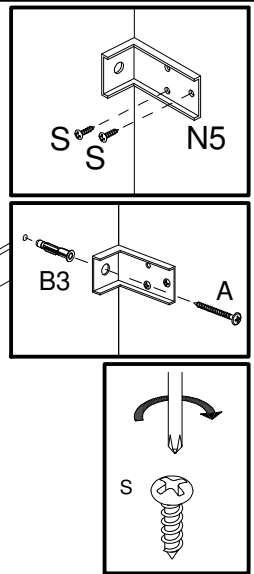
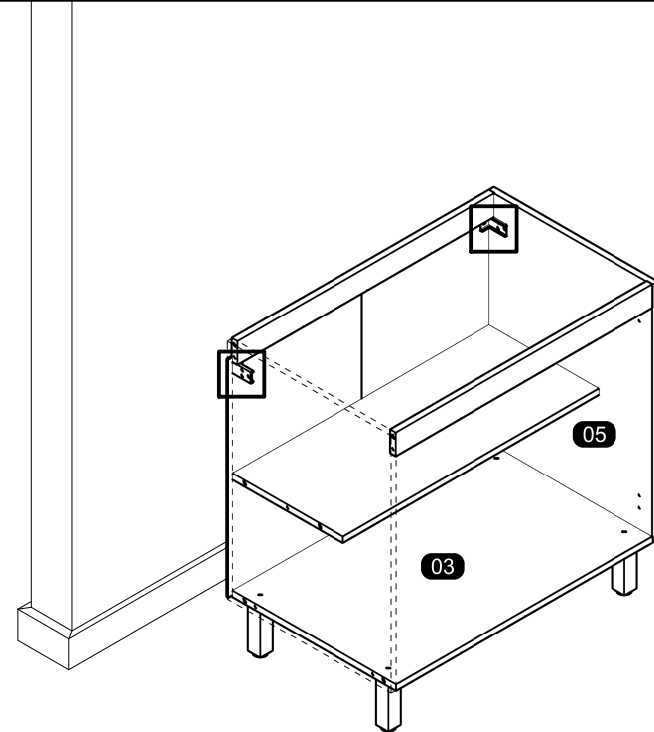

MOUNTING ON THE CHOSEN DOOR MODEL
 MONTAGEM NO MODELO DE PORTA ESCOLHIDO / MONTAJE EN EL MODELO DE PUERTA ELEGIDO

09

07

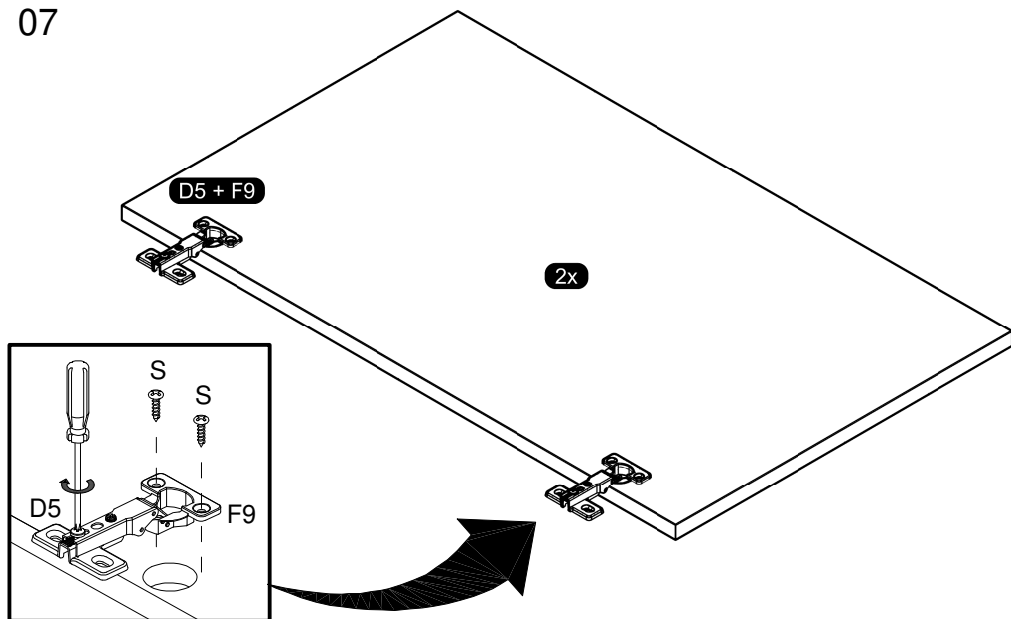

08

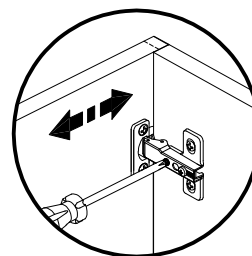
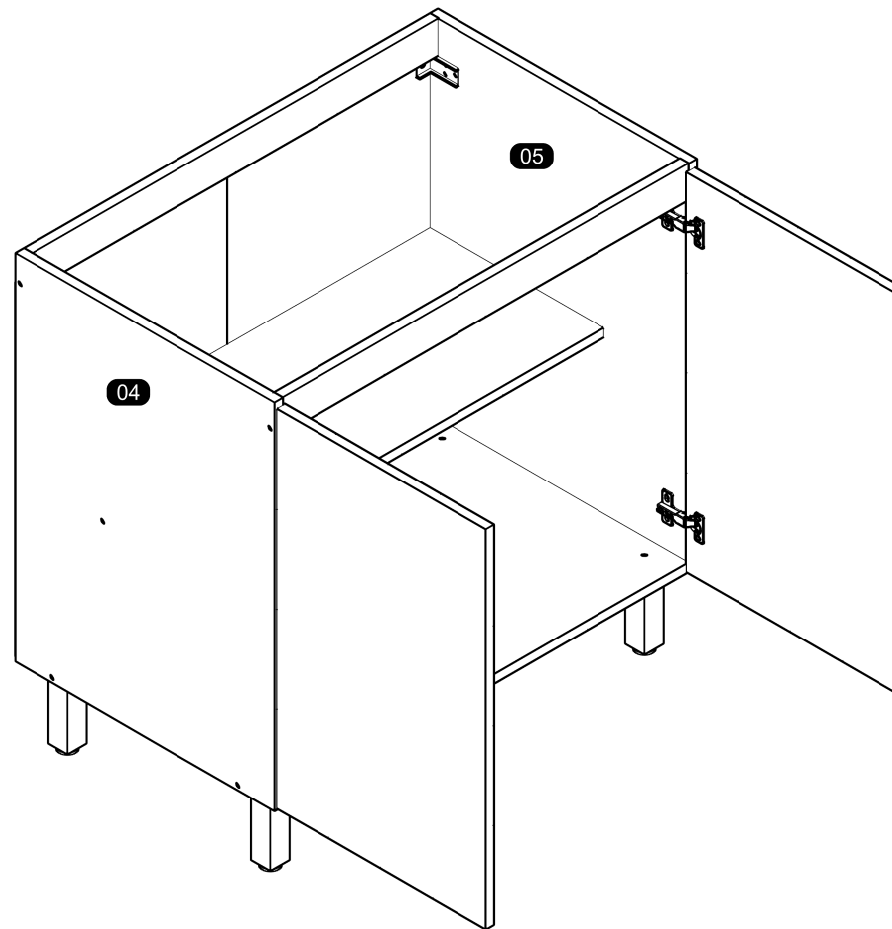
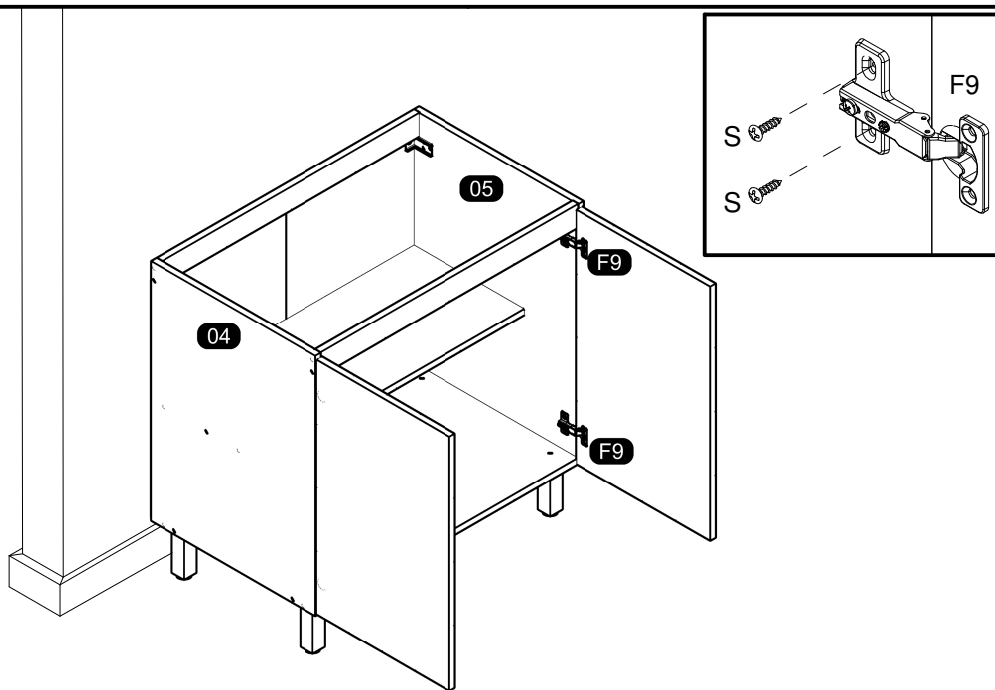

Horizontal Adjustment
 Regulagem Horizontal
 Ajuste Horizontal

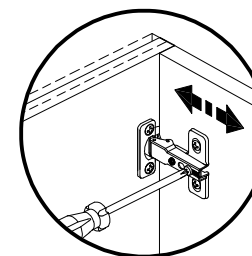

Depth Adjustment
 Regulagem Profundidade
 Ajuste Profundidade

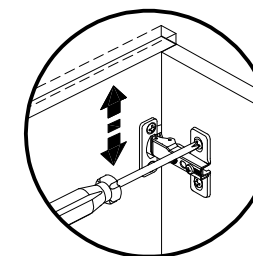

Vertical Adjustment
 Regulagem Vertical
 Ajuste Vertical

ASSEMBLY INSTRUCTIONS MANUAL DE MONTAGEM / INSTRUCCIONES DE ARMADO

CABINET 2 DOORS 3 DRAWERS
BALCÃO 2P 3G
GABINETE 2 PUERTAS 3 CAJONES

Reference
Referência
Referencia

240503

Revise
Revisão
Revisión

00

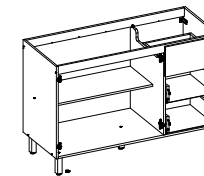

**YOU WILL NEED
VOCÊ VAI PRECISAR DE / USTED NECESITARÁ**

Tools not supplied
Ferramentas não fornecidas / Herramientas no incluidas

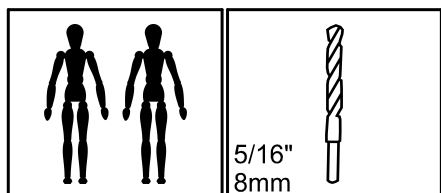

2 People
2 Pessoas
2 Personas

Drill bit
Broca
Taladro

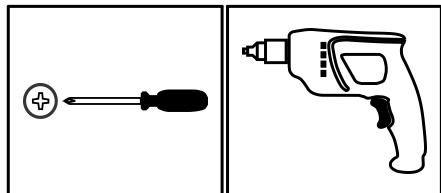

Screwdriver Phillips
Chave Phillips
Destornillador cruz

Drill machine
Furadeira
Taladro

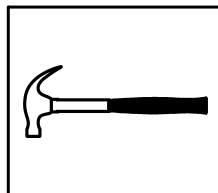

Hammer
Martelo
Martillo

**MAXIMUM RECOMMENDED WEIGHT
BEING THIS EVENLY DISTRIBUTED.**

**PESO MÁXIMO RECOMENDADO SENDO
ESTE DISTRIBUIDO UNIFORMEMENTE.**

**PESO MÁXIMO RECOMENDADO SIENDO
ESTE UNIFORMEMENTE DISTRIBUIDO.**

	LB	KG
C	6	3
D	11	5
F	22	10

**PARTS IDENTIFICATION
IDENTIFICAÇÃO DAS PEÇAS / IDENTIFICACIÓN DE LAS PIEZAS**

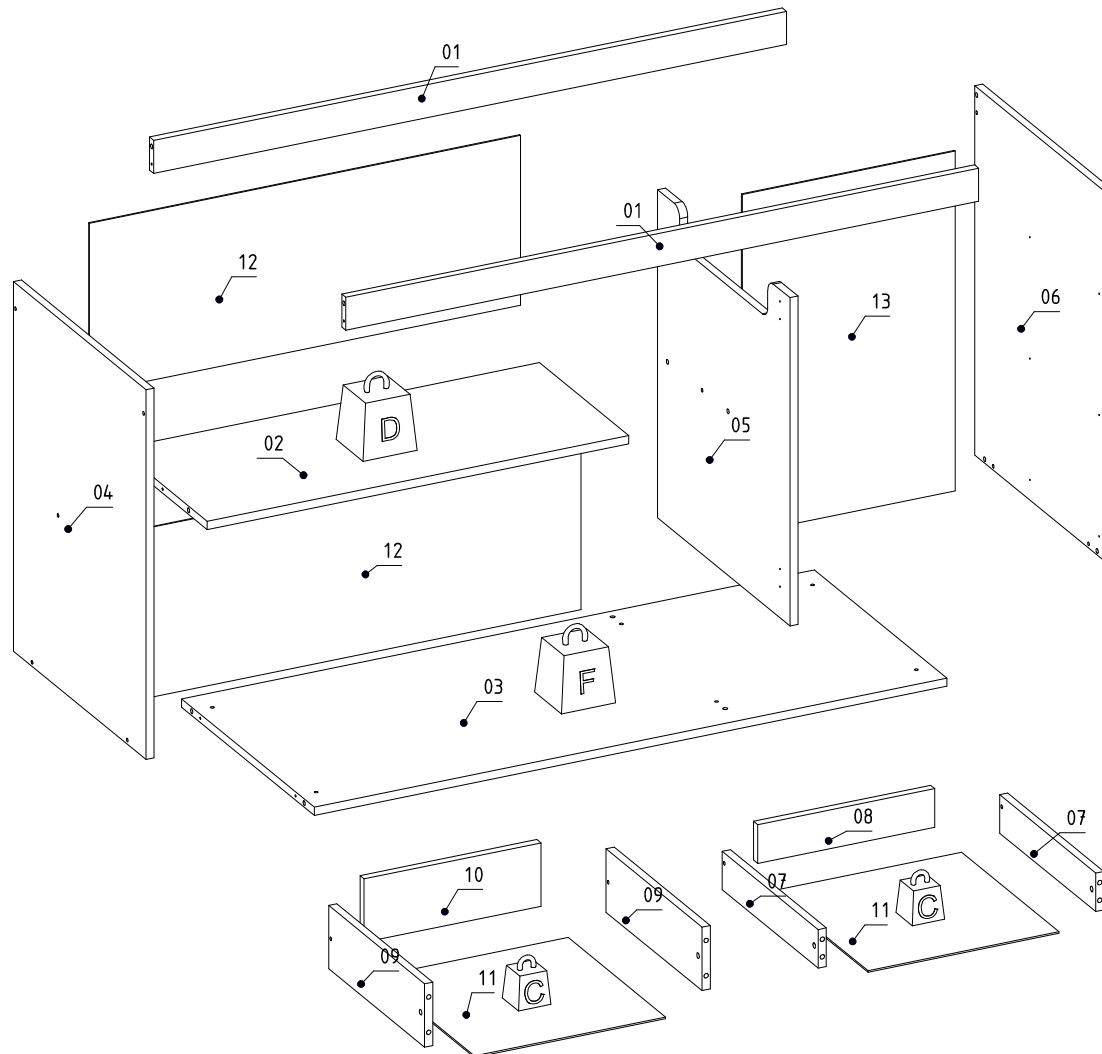

Nº	Measures_Inches	Medidas_cm	Qty./Qtd.
01	46 1/8 x 2 3/8 x 5/8	117.0 x 6.0 x 1.5	2
02	30 5/8 x 13 x 5/8	77.9 x 33.0 x 1.5	1
03	46 1/8 x 19 1/4 x 5/8	117.0 x 49.0 x 1.5	1
04	26 3/8 x 19 1/4 x 5/8	67.0 x 49.0 x 1.5	1
05	19 1/4 x 23 3/8 x 5/8	49.0 x 59.5 x 1.5	1
06	26 3/8 x 19 1/4 x 5/8	67.0 x 49.0 x 1.5	1
07	14 x 2 3/4 x 5/8	35.5 x 7.0 x 1.5	2
08	12 7/8 x 2 3/4 x 5/8	32.7 x 7.0 x 1.5	1
09	14 x 4 1/2 x 5/8	35.5 x 11.5 x 1.5	4
10	12 7/8 x 4 1/2 x 5/8	32.7 x 11.5 x 1.5	2
11	14 1/8 x 13 7/8 x 1/8	36.0 x 35.3 x 0.3	3
12	31 3/8 x 12 1/8 x 1/8	79.7 x 30.8 x 0.3	2
13	24 1/4 x 15 1/2 x 1/8	61.6 x 39.4 x 0.3	1

IDENTIFICATION OF ACCESSORIES IDENTIFICAÇÃO DOS ACESSÓRIOS/ IDENTIFICACIÓN DE ACCESORIOS



The separation of the accessories before you start the assembly will facilitate the same. In case of doubt on the size of the screws and bolts, use the ruler at the bottom of the page.
 A separação dos acessórios antes de iniciar a montagem facilitará a mesma. Em caso de dúvida no tamanho dos parafusos e cavilhas, utilize a régua ao final da página.
 La separación de los accesorios antes de comenzar el armado facilitará el mismo. En caso de duda sobre el tamaño de los tornillos y taquetes, utilice la regla al pie de página.

A		Flanged head screw Parafuso flangeado / Tornillo de cabeza flangeada	5,0x60 mm	2
A3		Trapeze Trapézio / Trapecio	-	6
A23		Foot Pé Quadrado FP / Pie	140 mm	5
B3		Bushing Bucha expansiva / Tapón	8x50 mm	2
C		Flanged head screw Parafuso flangeado / Tornillo de cabeza flangeada	4,5x45 mm	5
C1		Metal claw Garra de metal / Garra metal	-	7
D		Flat head screw Parafuso chato / Tornillo de cabeza plana	4,0x40 mm	6
D5		Hinge shim Calço dobradiça / Bisagra de calce	-	4
F6		Metal hinge curve Dobradiça curva / Esquina de bisagra metálica	26 mm	2
F9		Metal hinge straight Dobradiça reta / Bisagra recta	26 mm	2
E		Wooden dowel Cavilha / Taquete	8x30 mm	26
L9		Flat head screw Parafuso chato / Tornillo de cabeza plana	3,5x12 mm	30
L17		Telescopic slide Corrediça telescópica / Corredera telescópica	350 mm	6
M		Bore patch adhesive Tapa furo adesivo / Tapones adhesivo	-	20
N		Nail Prego / Clavo	10x10	65
N5		Support "L" Suporte "L" / Soporte "L"	-	2
O		Flat head screw Parafuso chato / Tornillo de cabeza plana	4,5x45 mm	12
P		Pan head screw Parafuso panela / Tornillo de pan	4,5x25 mm	6
S		Pan head screw Parafuso panela / Tornillo de pan	3,5x14 mm	24
Y18		Zamac bracket Cantoneira zamac/ Suporte de zamac	13x13 mm	2



PRE-ASSEMBLE PRÉ-MONTAGEM / PRE ARMADO

01

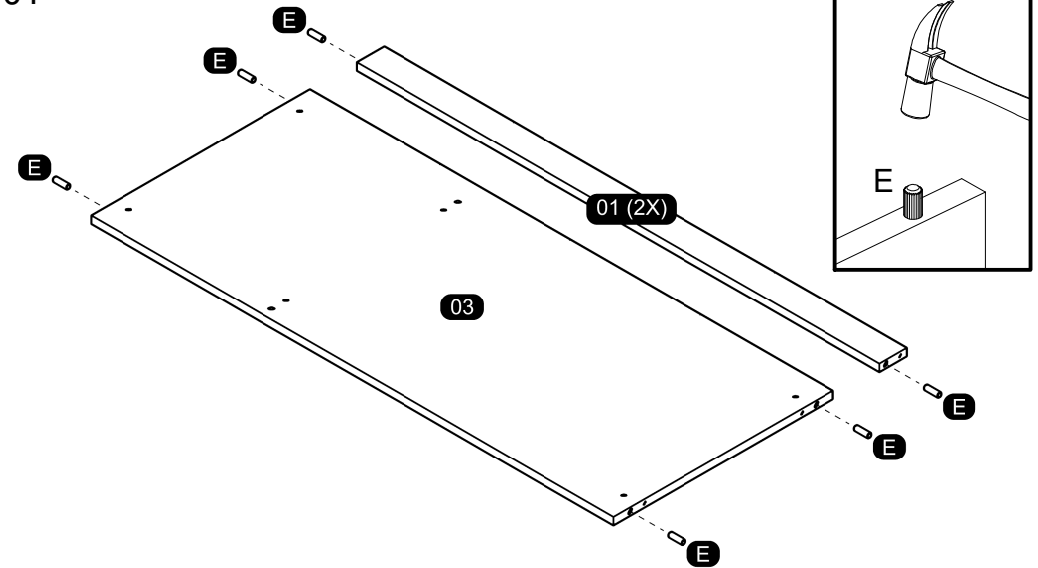

02

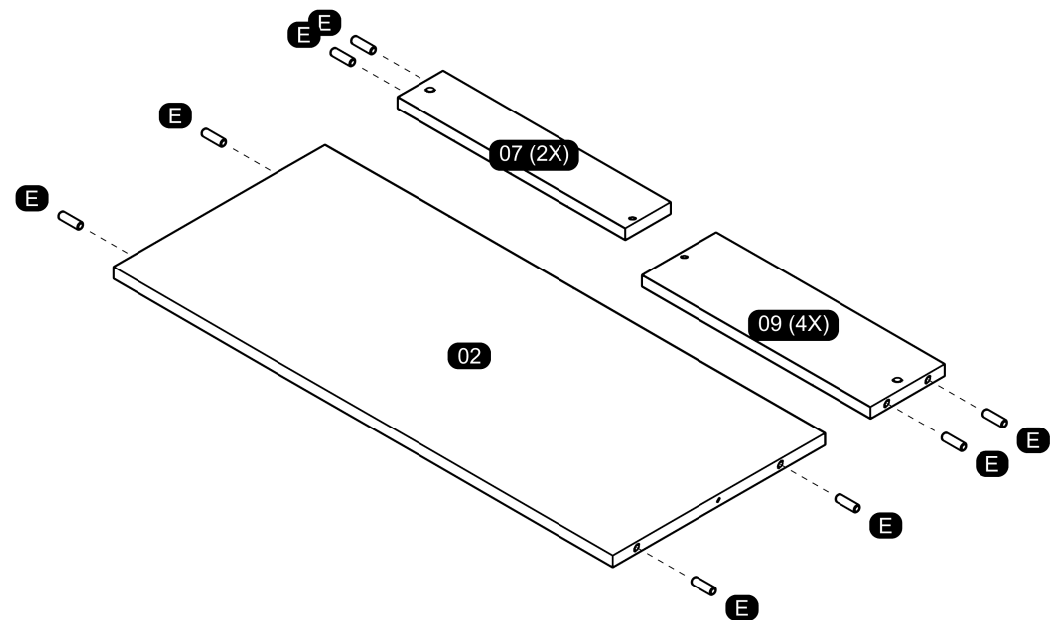

03

SEPARATE THE TWO PARTS OF THE METAL SLIDE TO THE ASSEMBLY FOLLOWING THE INSTRUCTIONS BELOW.
 SEPARARE AS DUAS PARTES DA CORREDEIRA METÁLICA PARA A MONTAGEM SEGUINDO AS INSTRUÇÕES ABAIXO.
 SEPARAR LAS DOS PARTES DE LA CORREDEIRA DE METAL PARA EL ARMADO Y SEGUIR LAS INSTRUCCIONES ABAJO.

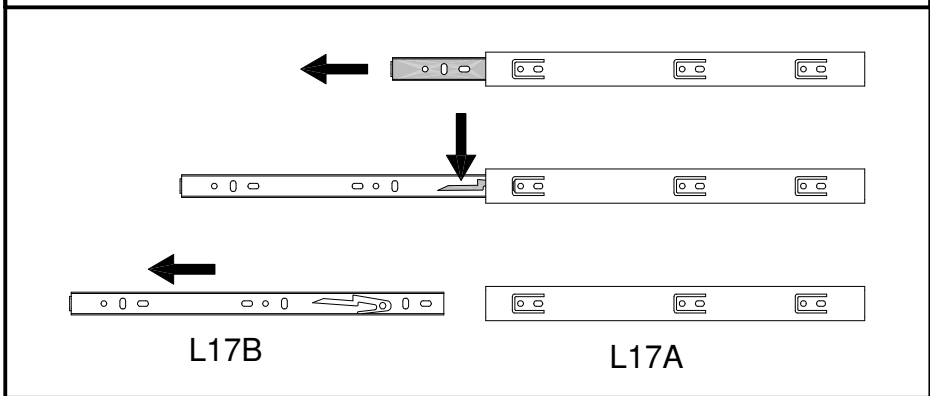

05

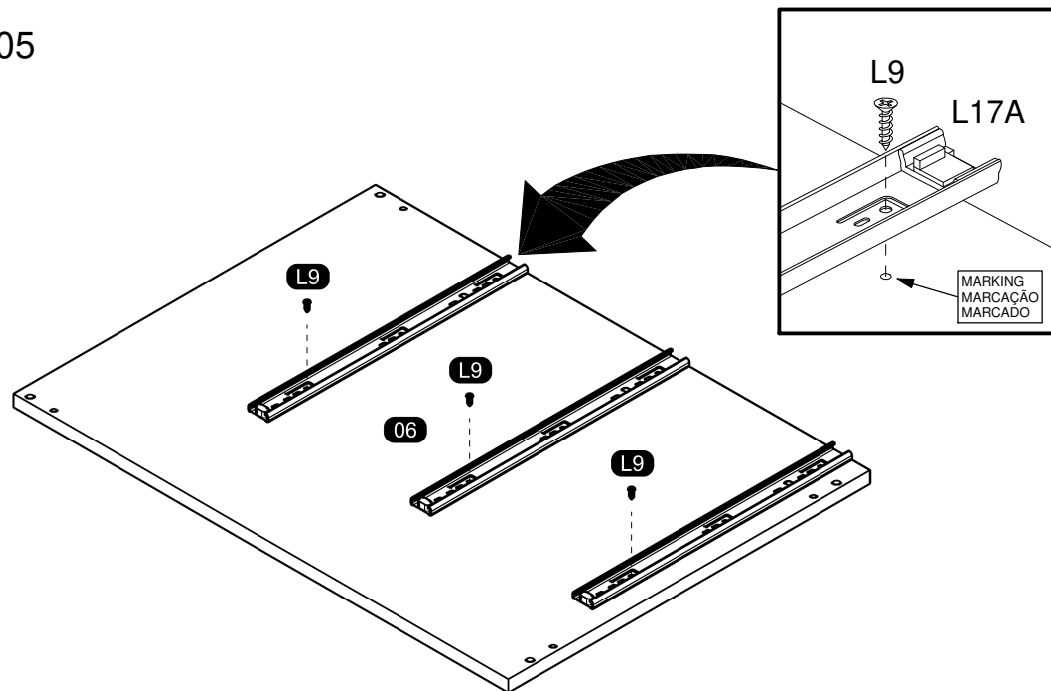

04

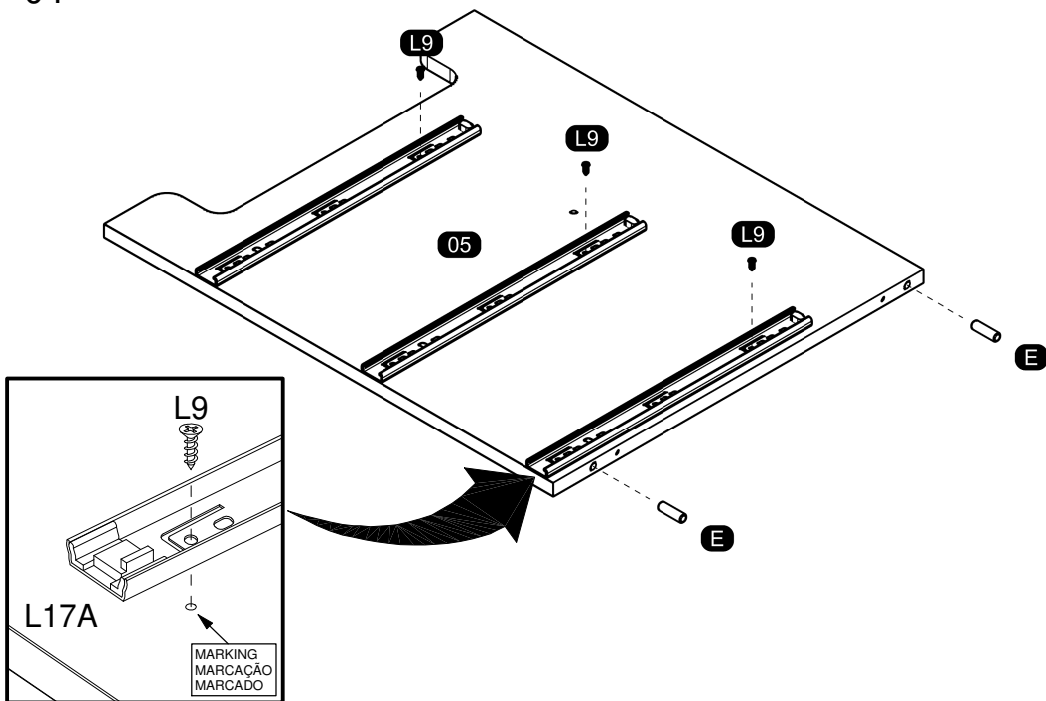

**ASSEMBLY
MONTAGEM / ARMADO**

06

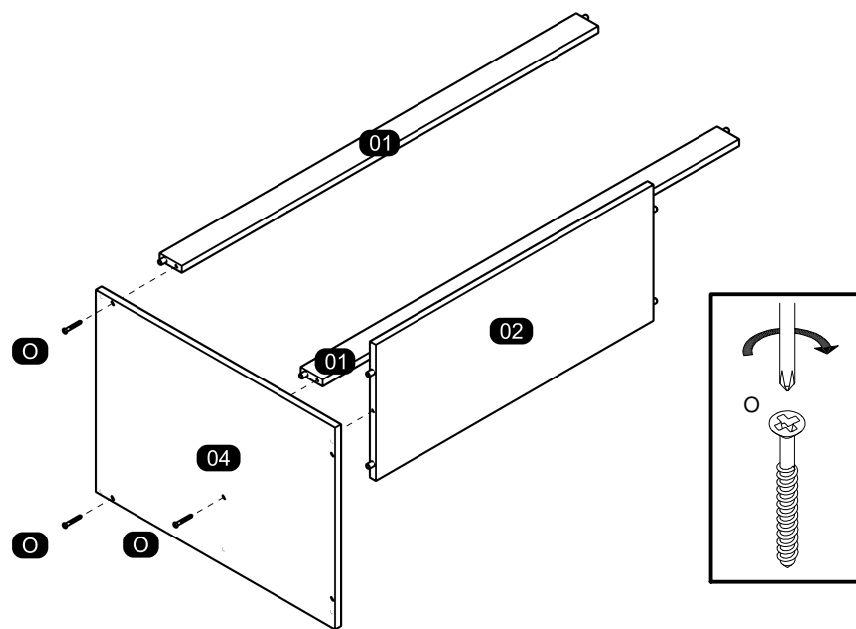

07

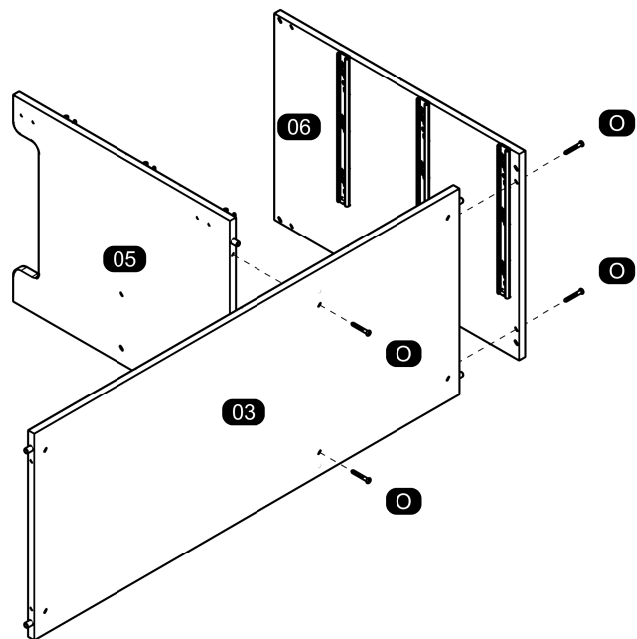

09

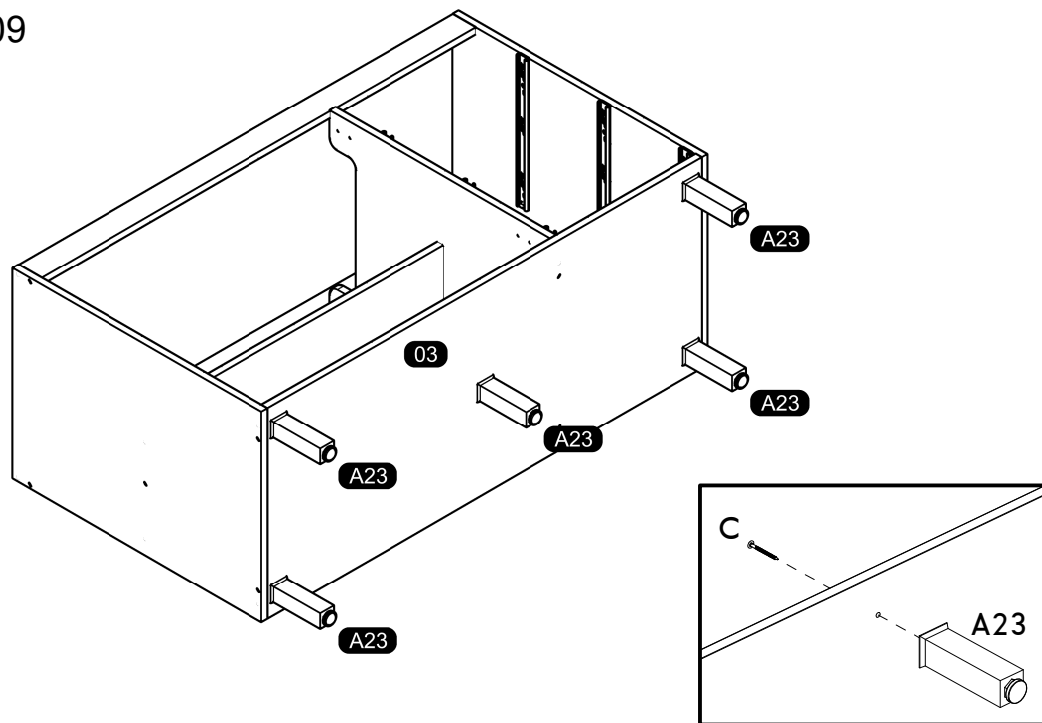

08

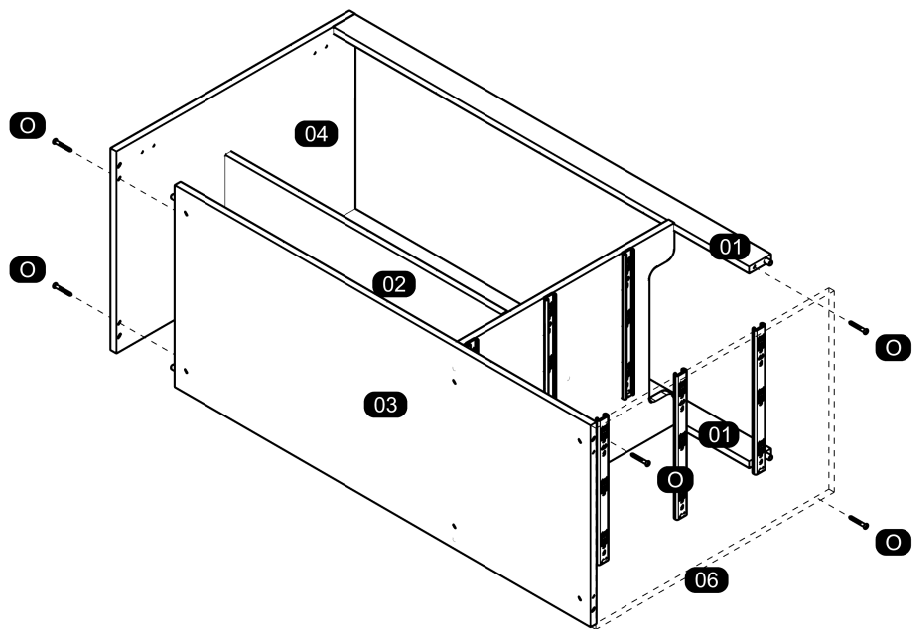

10

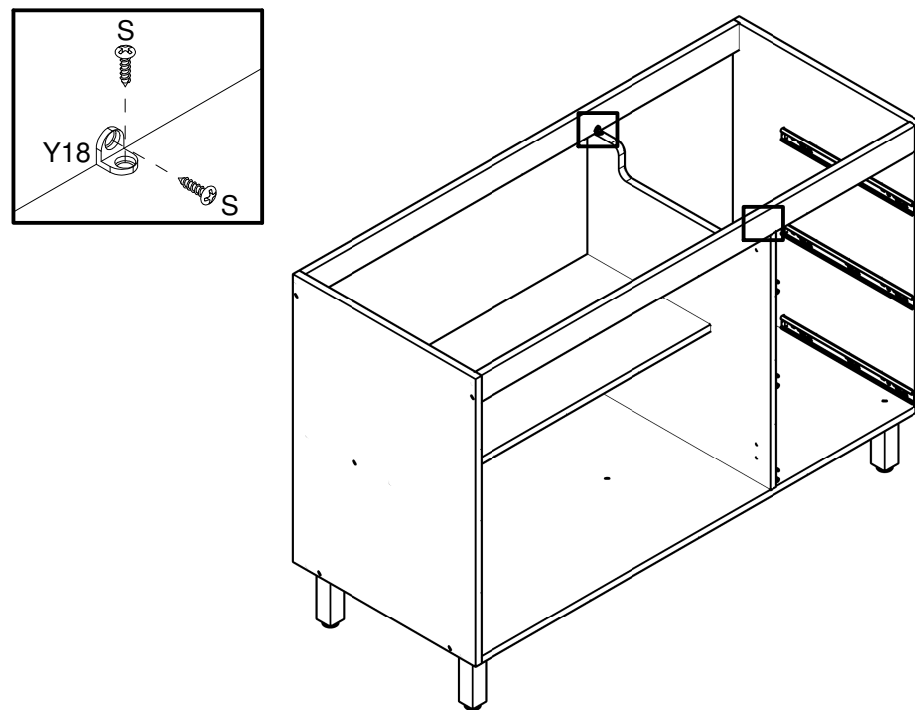

11

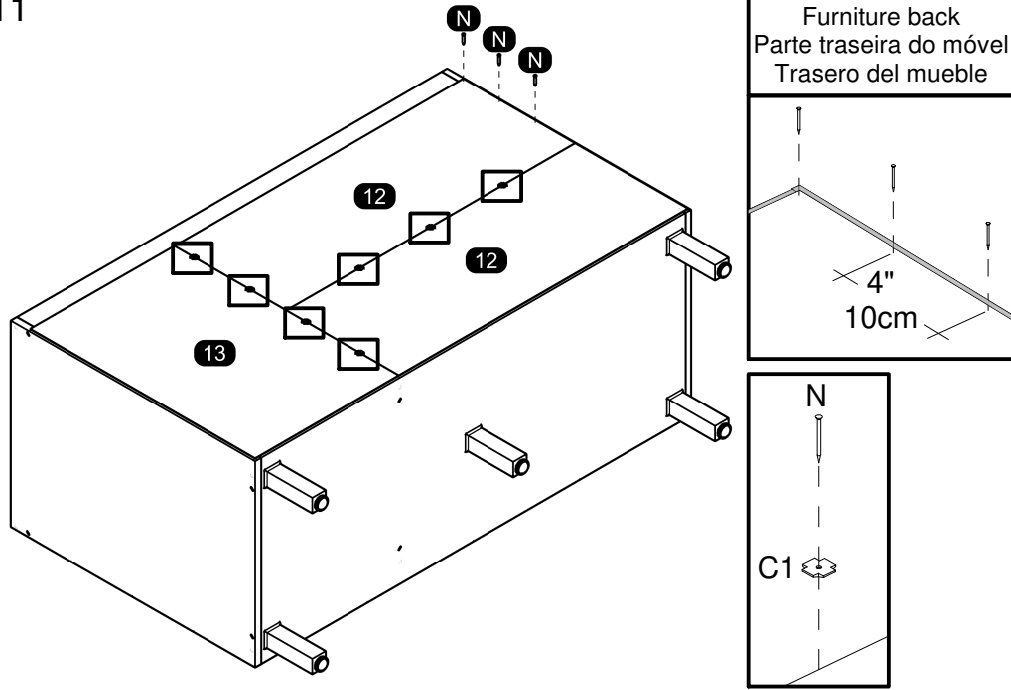

MOUNTING ON THE CHOSEN DRAWER FRONT MODEL
MONTAGEM NO MODELO DE FRENTE DE GAVETA ESCOLHIDO / MONTAJE EN EL MODELO DE FRENTE DE CAJÓN ELEGIDO

13

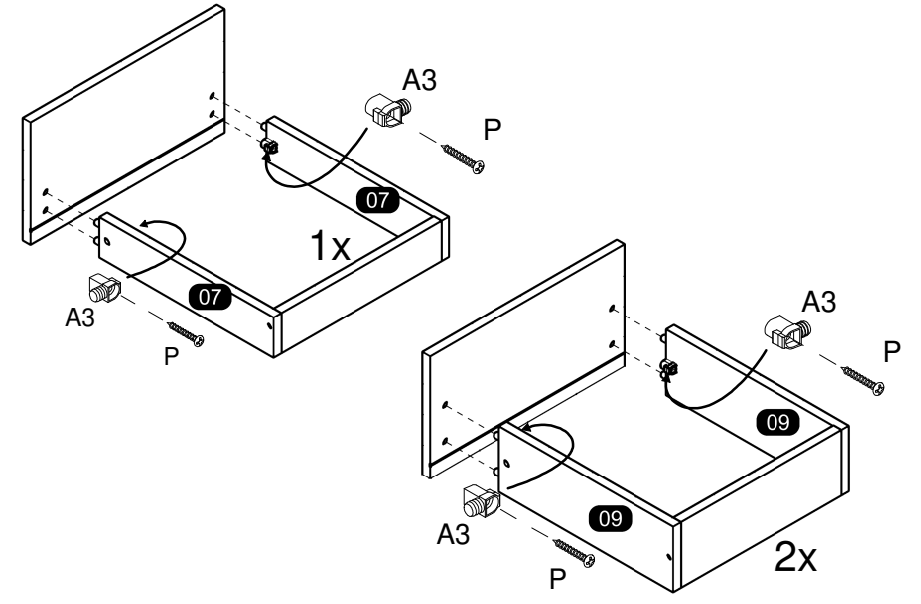

12

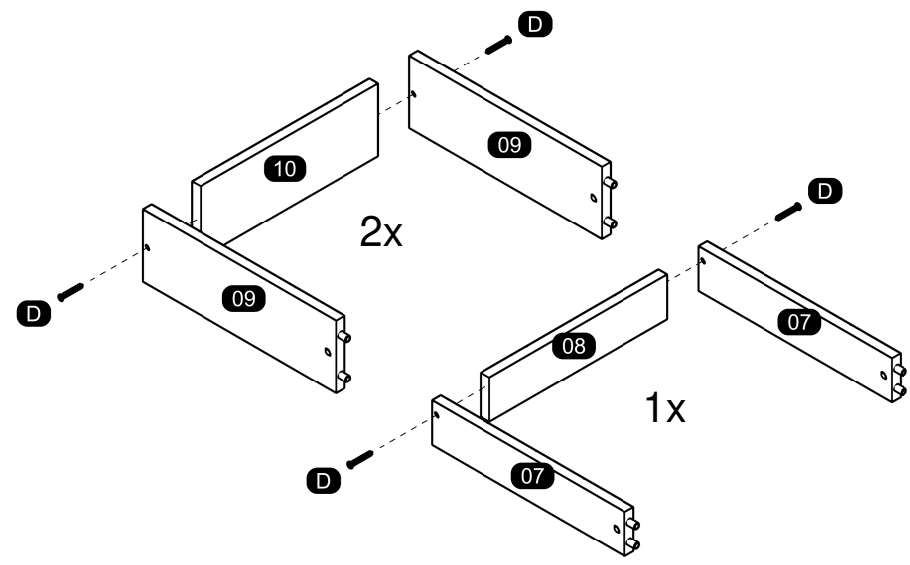

14

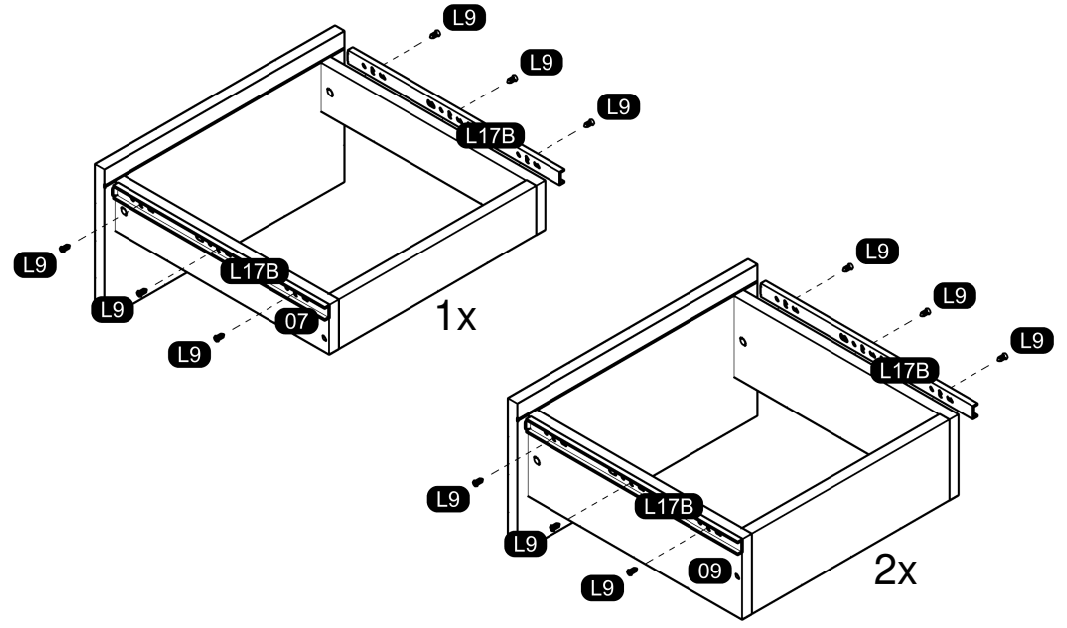

15

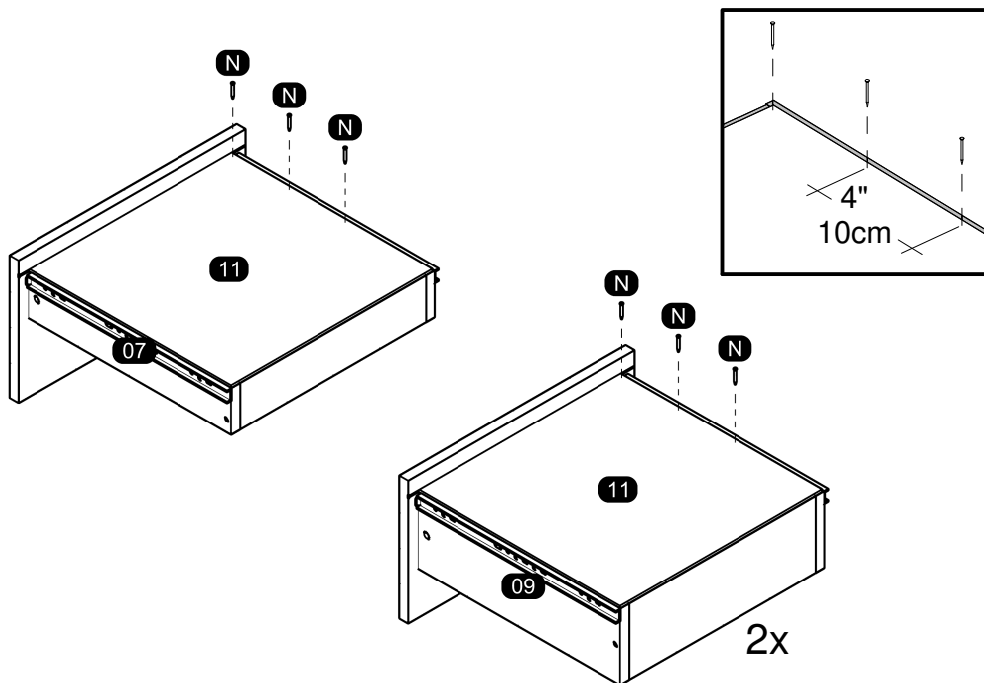

17

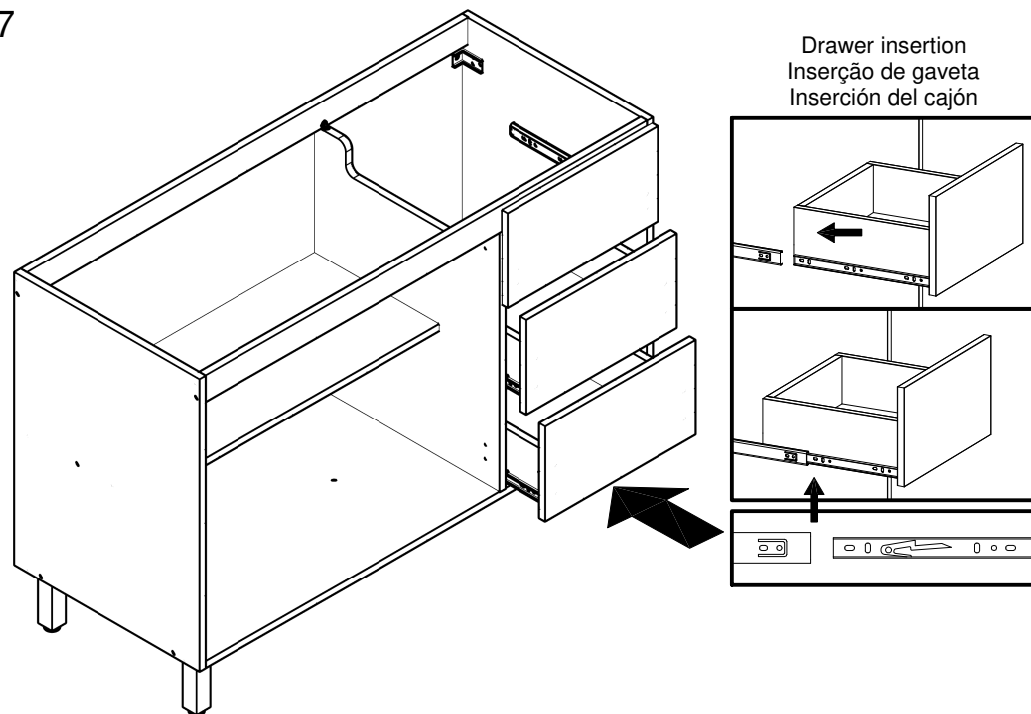

16

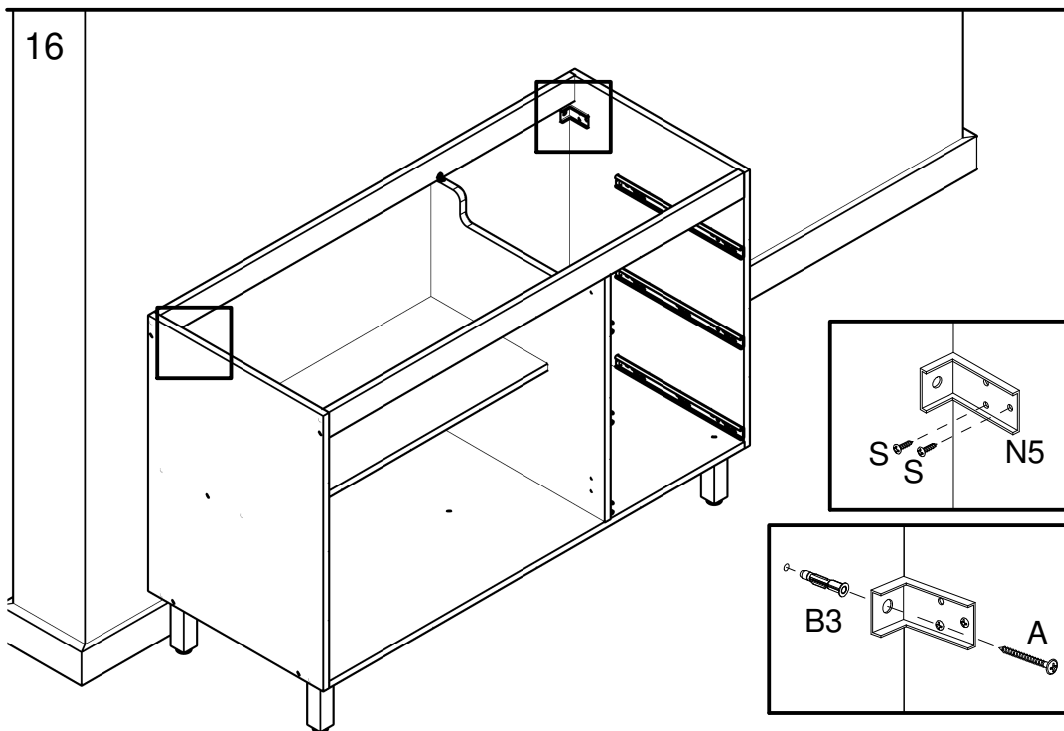

At the end of the assembly, insert the screw cover / hole plugs in the apparent holes.
Ao final da montagem, insira a(s) tampa(s) de parafuso / tapa furos nos furos que ficarem aparentes.
Al final del conjunto, coloque la tapa tornillo / tapón plástico en los agujeros que se hagan evidentes.

18

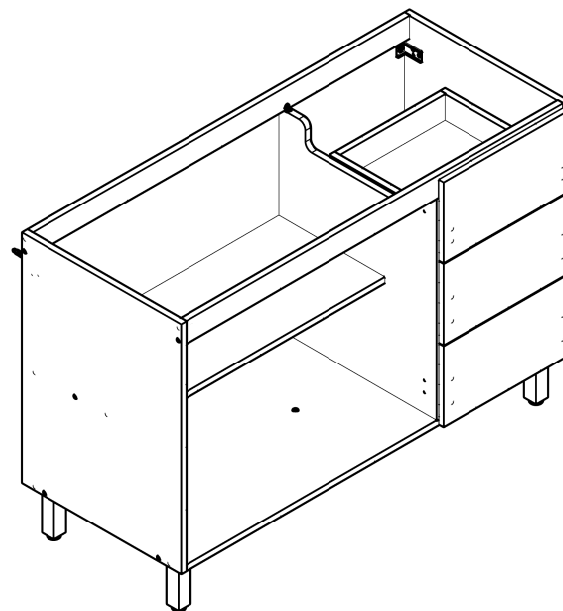

ASSEMBLY INSTRUCTIONS MANUAL DE MONTAGEM / INSTRUCCIONES DE ARMADO

TOWER 2 FLAP DOORS 1 DRAWER 19 5/16

TORRE 2P BASCULANTE 1G 490MM

TORRE 2 PUERTAS HORIZONTALES 1 CAJÓN 490MM

Reference
Referência
Referencia

240523

Revise
Revisão
Revisión

00

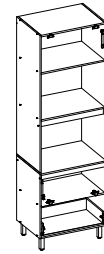

**YOU WILL NEED
VOCÊ VAI PRECISAR DE / USTED NECESITARÁ**

Tools not supplied
Ferramentas não fornecidas / Herramientas no incluidas

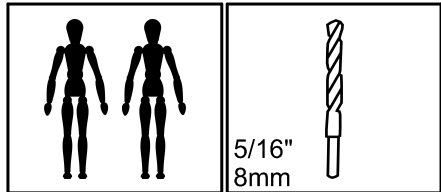

2 People
2 Pessoas
2 Personas

Drill bit
Broca
Taladro

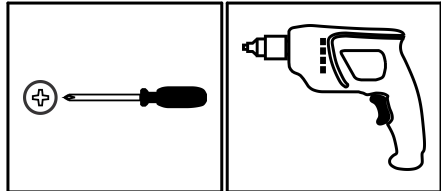

Screwdriver Phillips
Chave Phillips
Destornillador cruz

Drill machine
Furadeira
Taladro

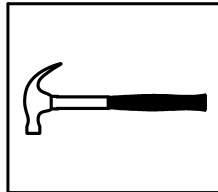

Hammer
Martelo
Martillo

**MAXIMUM RECOMMENDED WEIGHT
BEING THIS EVENLY DISTRIBUTED.**

**PESO MÁXIMO RECOMENDADO SENDO
ESTE DISTRIBUÍDO UNIFORMEMENTE.**

**PESO MÁXIMO RECOMENDADO SIENDO
ESTE UNIFORMEMENTE DISTRIBUIDO.**

	LB	KG
D	11	5
E	17	8
F	22	10

**PARTS IDENTIFICATION
IDENTIFICAÇÃO DAS PEÇAS / IDENTIFICACIÓN DE LAS PIEZAS**

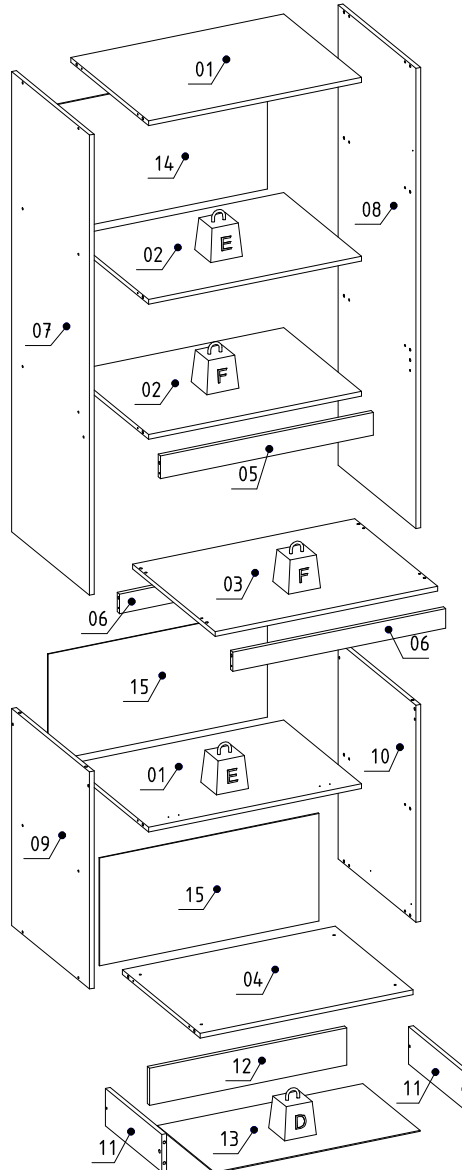

Nº	Measures_Inches	Medidas_cm	Qty./Qtd.
01	26 3/8 x 19 1/4 x 5/8	67.0 x 49.0 x 1.5	2
02	26 3/8 x 19 1/4 x 5/8	67.0 x 49.0 x 1.5	2
03	27 1/2 x 20 1/2 x 5/8	70.0 x 52.0 x 1.5	1
04	26 3/8 x 19 1/4 x 5/8	67.0 x 49.0 x 1.5	1
05	26 3/8 x 2 3/4 x 5/8	67.0 x 7.0 x 1.5	1
06	26 3/8 x 2 3/8 x 5/8	67.0 x 6.0 x 1.5	2
07	55 7/8 x 19 1/4 x 5/8	142.0 x 49.0 x 1.5	1
08	55 7/8 x 19 1/4 x 5/8	142.0 x 49.0 x 1.5	1
09	26 3/8 x 19 1/4 x 5/8	67.0 x 49.0 x 1.5	1
10	26 3/8 x 19 1/4 x 5/8	67.0 x 49.0 x 1.5	1
11	14 x 4 1/2 x 5/8	35.5 x 11.5 x 1.5	2
12	24 1/2 x 4 1/2 x 5/8	62.1 x 11.5 x 1.5	1
13	25 1/2 x 14 1/8 x 1/8	64.7 x 36.0 x 0.3	1
14	27 1/8 x 15 1/2 x 1/8	69.0 x 39.3 x 0.3	1
15	27 1/8 x 13 1/8 x 1/8	69.0 x 33.2 x 0.3	2

IDENTIFICATION OF ACCESSORIES IDENTIFICAÇÃO DOS ACESSÓRIOS/ IDENTIFICACIÓN DE ACCESORIOS



The separation of the accessories before you start the assembly will facilitate the same. In case of doubt on the size of the screws and bolts, use the ruler at the bottom of the page.
 A separação dos acessórios antes de iniciar a montagem facilitará a mesma. Em caso de dúvida no tamanho dos parafusos e cavilhas, utilize a régua ao final da página.
 La separación de los accesorios antes de comenzar el armado facilitará el mismo. En caso de duda sobre el tamaño de los tornillos y taquetes, utilice la regla al pie de página.

A		Flanged head screw Parafuso flangeado / Tornillo de cabeza flangeada	5,0x60 mm	2
A3		Trapeze Trapézio / Trapecio	-	2
A4		Metalic bracket Cantoneira de metal / Soporte de metal	22x22 mm	7
A23		Foot Pé Quadrado FP / Pie	140 mm	4
B3		Bushing Bucha expansiva / Tapón	8x50 mm	2
C		Flanged head screw Parafuso flangeado / Tornillo de cabeza flangeada	4,5x45 mm	4
C1		Metal claw Garra de metal / Garra metal	-	3
D		Flat head screw Parafuso chato / Tornillo de cabeza plana	4,0x40 mm	2
E		Wooden dowel Cavilha / Taquete	8x30 mm	30
F		Wooden dowel Cavilha / Taquete	8x50 mm	4
L9		Flat head screw Parafuso chato / Tornillo de cabeza plana	3,5x12 mm	10
L17		Telescopic slide Corrediça telescópica / Corredera telescópica	350 mm	2
N		Nail Prego / Clavo	10x10	69
N5		Support "L" Suporte "L" / Soporte "L"	-	2
O		Flat head screw Parafuso chato / Tornillo de cabeza plana	4,5x45 mm	30
P		Pan head screw Parafuso panela / Tornillo de pan	4,5x25 mm	2
S		Pan head screw Parafuso panela / Tornillo de pan	3,5x14 mm	42
S7A		Gas piston Pistão a gás / Pistón de gas	-	2
S7B		Side support piston Suporte pistão lateral / Soporte pistón lateral	-	2
S7C		Door support piston Suporte pistão porta / Soporte pistón puerta	-	2
S7D		Pan head screw Parafuso panela / Tornillo de pan	3,5x12 mm	10
Z13		Metal hinge straight Dobradiça reta / Bisagra recta	35 mm	4



PRE-ASSEMBLE PRÉ-MONTAGEM / PRE ARMADO

01

SEPARATE THE TWO PARTS OF THE METAL SLIDE TO THE ASSEMBLY FOLLOWING THE INSTRUCTIONS BELOW.
 SEPARAR AS DUAS PARTES DA CORREDIÇA METÁLICA PARA A MONTAGEM SEGUINDO AS INSTRUÇÕES ABAIXO.
 SEPARAR LAS DOS PARTES DE LA CORREDERA DE METAL PARA EL ARMADO Y SEGUIR LAS INSTRUCCIONES ABAJO.

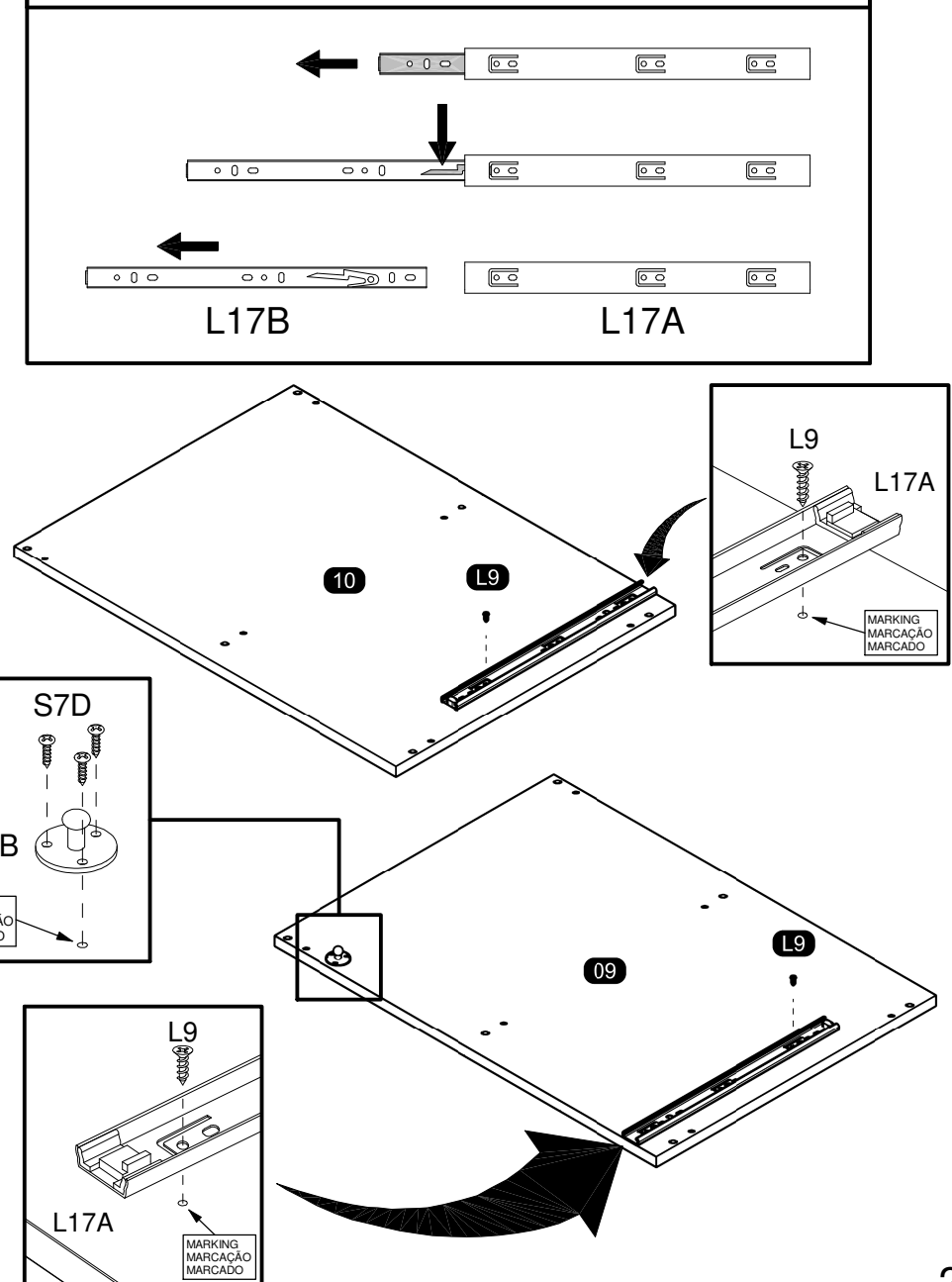

02

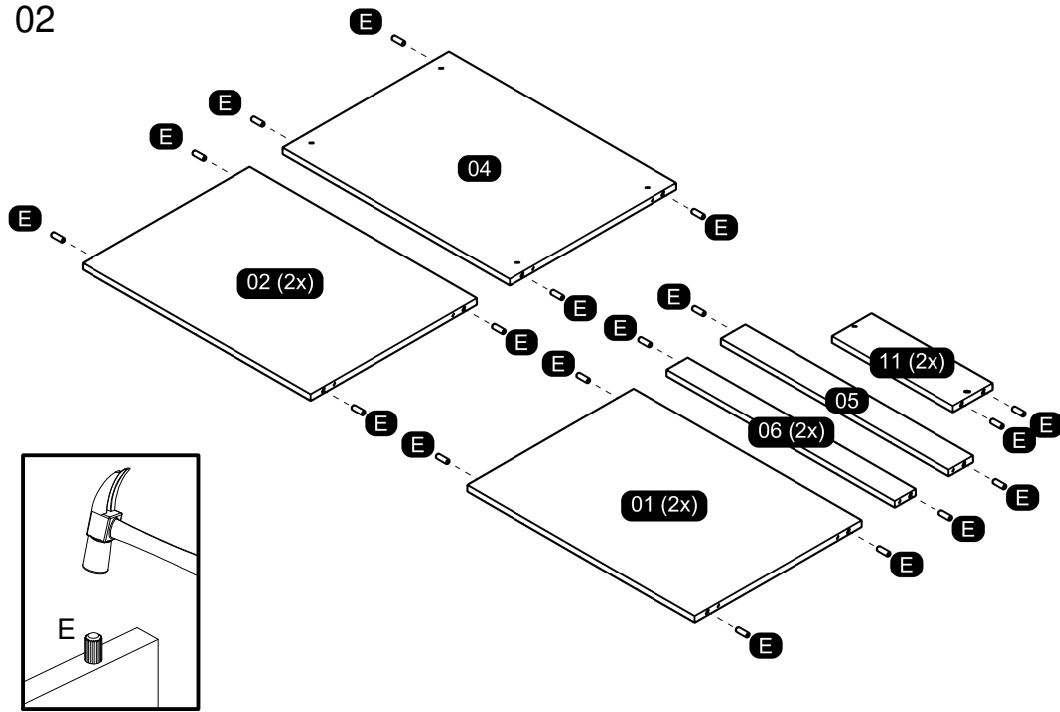

03

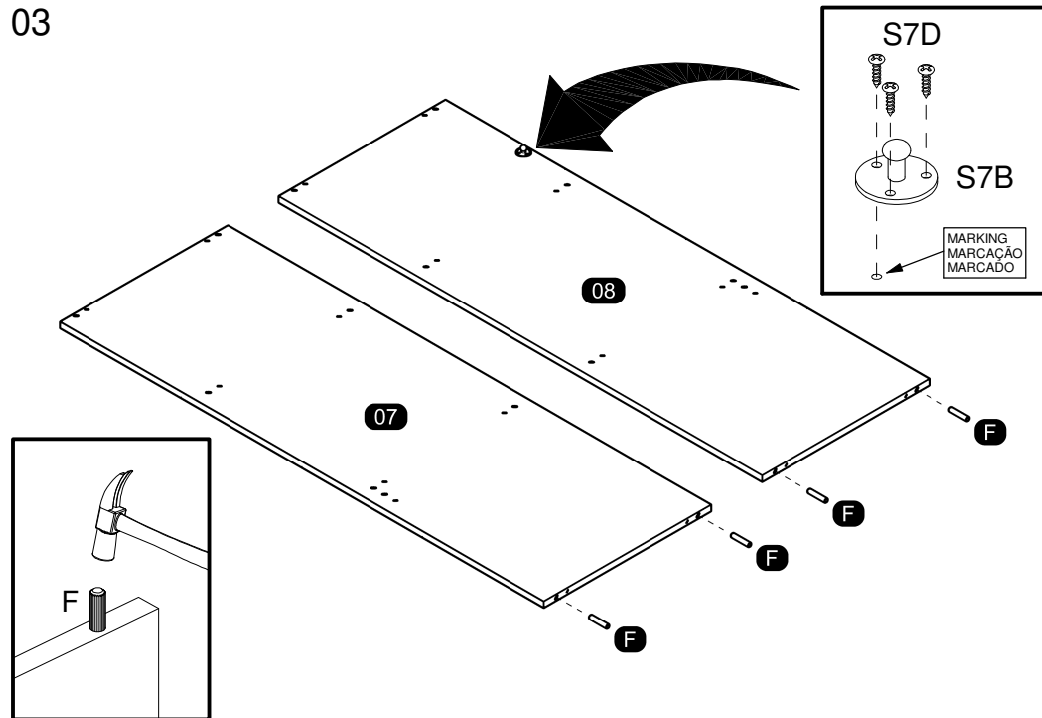

MOUNTING ON THE CHOSEN DOOR MODEL
 MONTAGEM NO MODELO DE PORTA ESCOLHIDO / MONTAJE EN EL MODELO DE PUERTA ELEGIDO

04

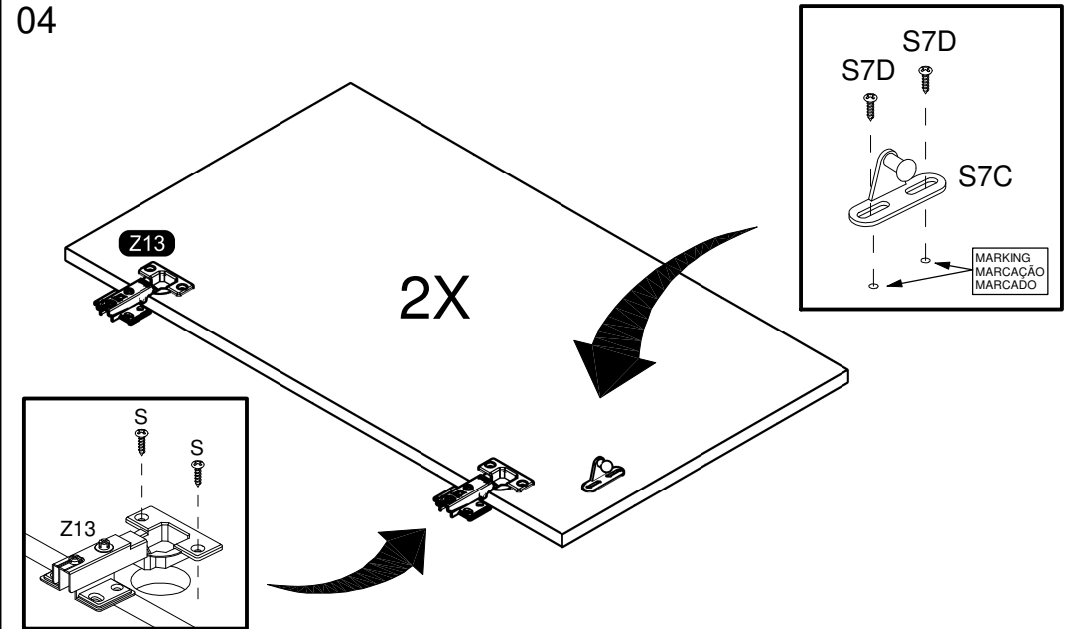

ASSEMBLY
 MONTAGEM / ARMADO

05

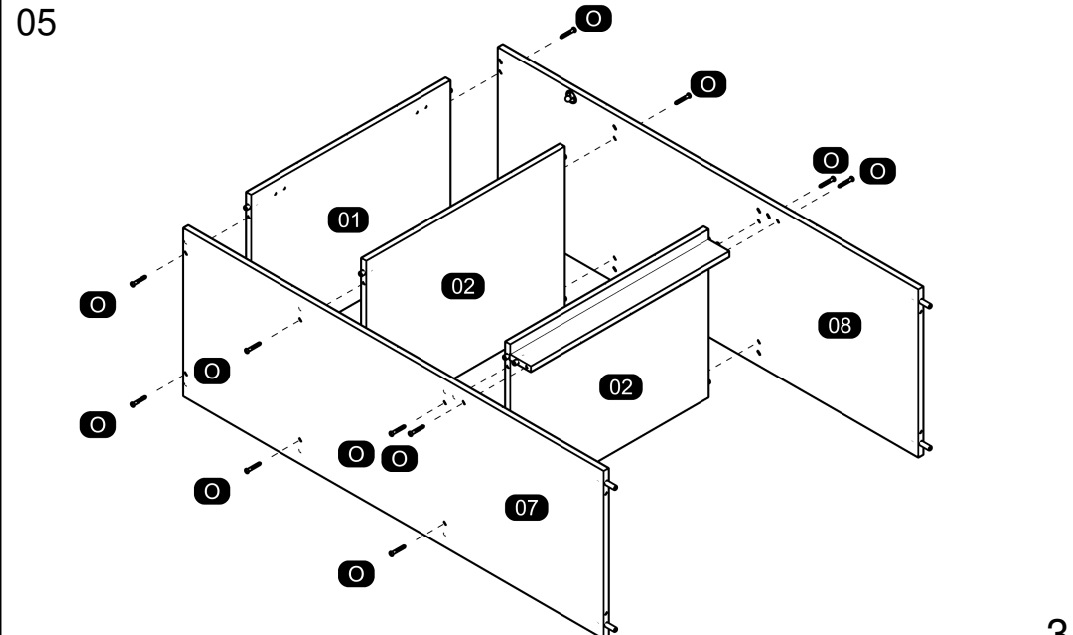

06

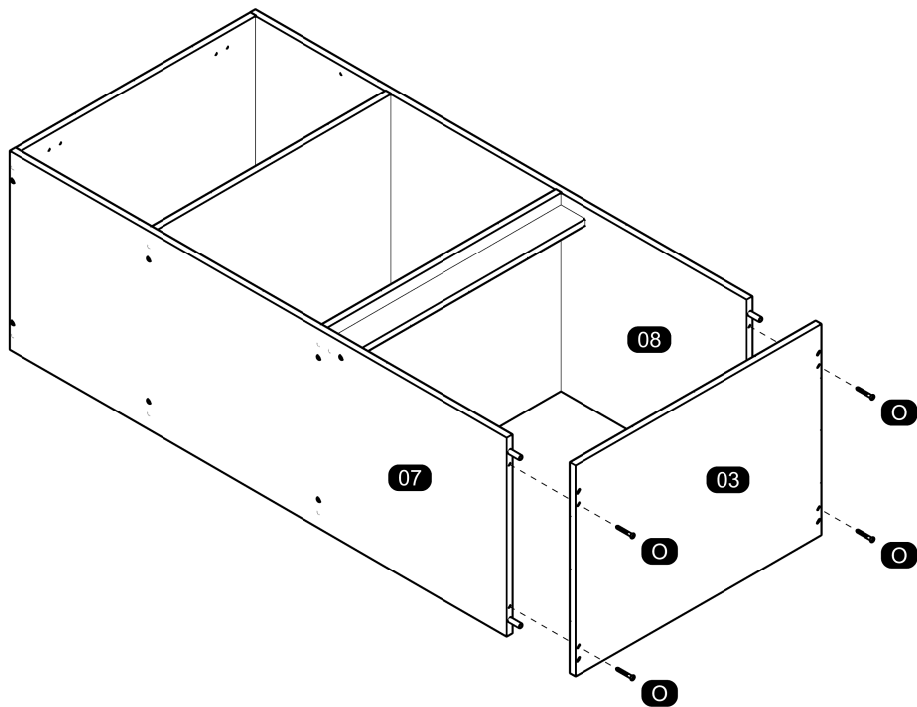

08

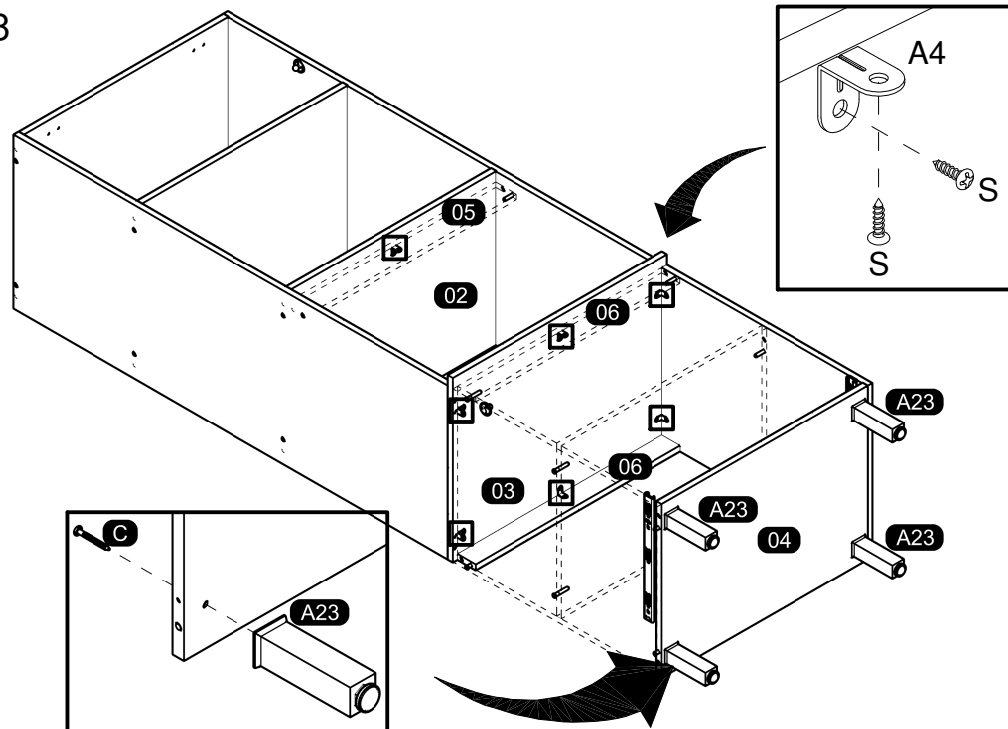

07

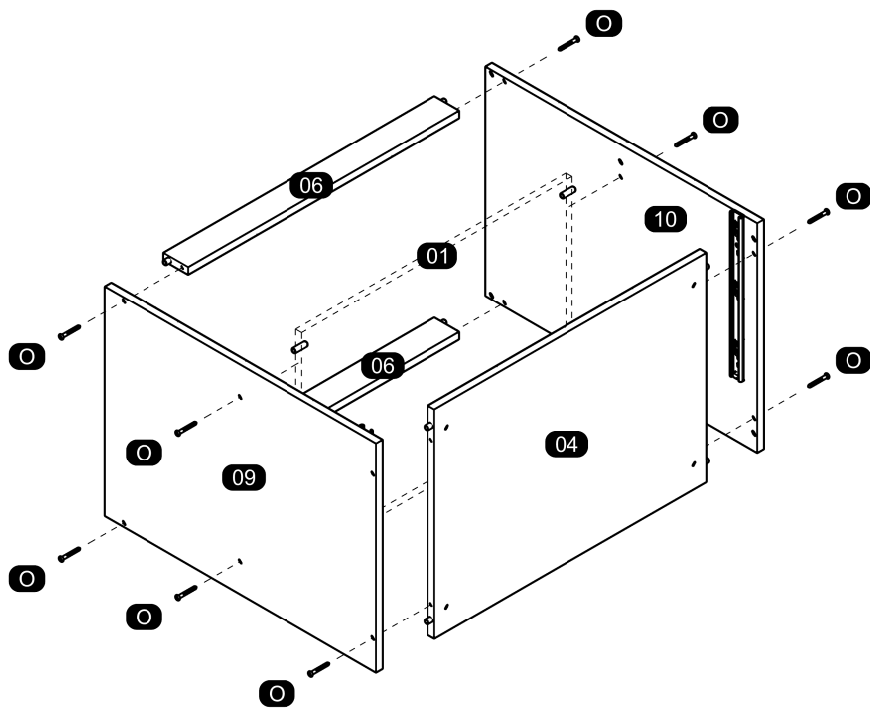

09

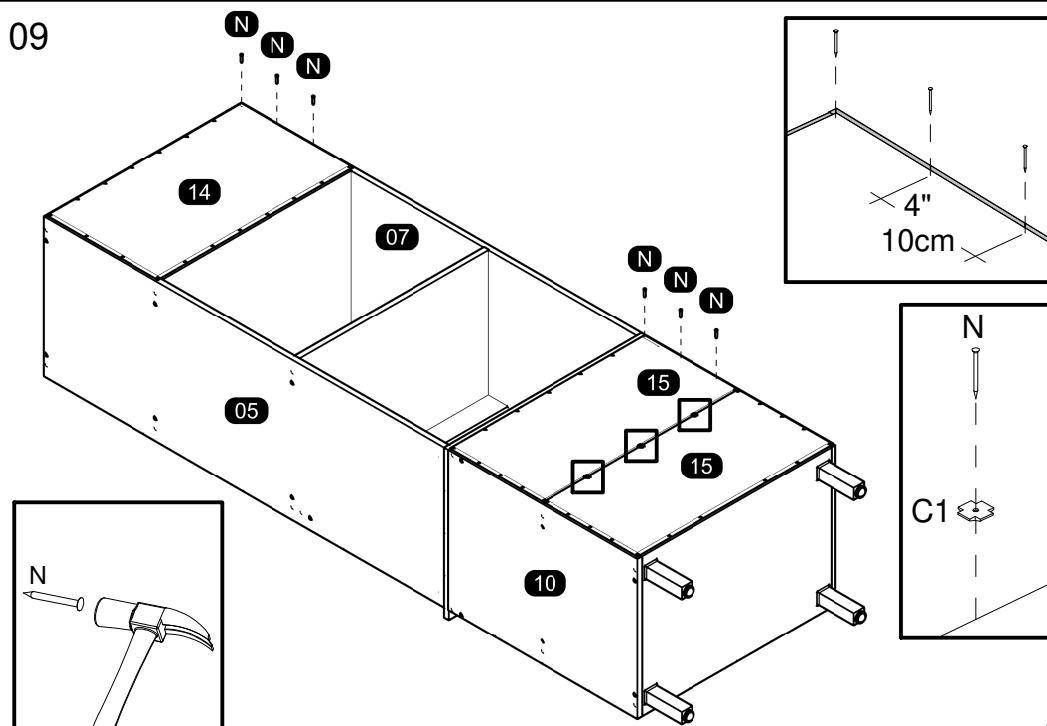

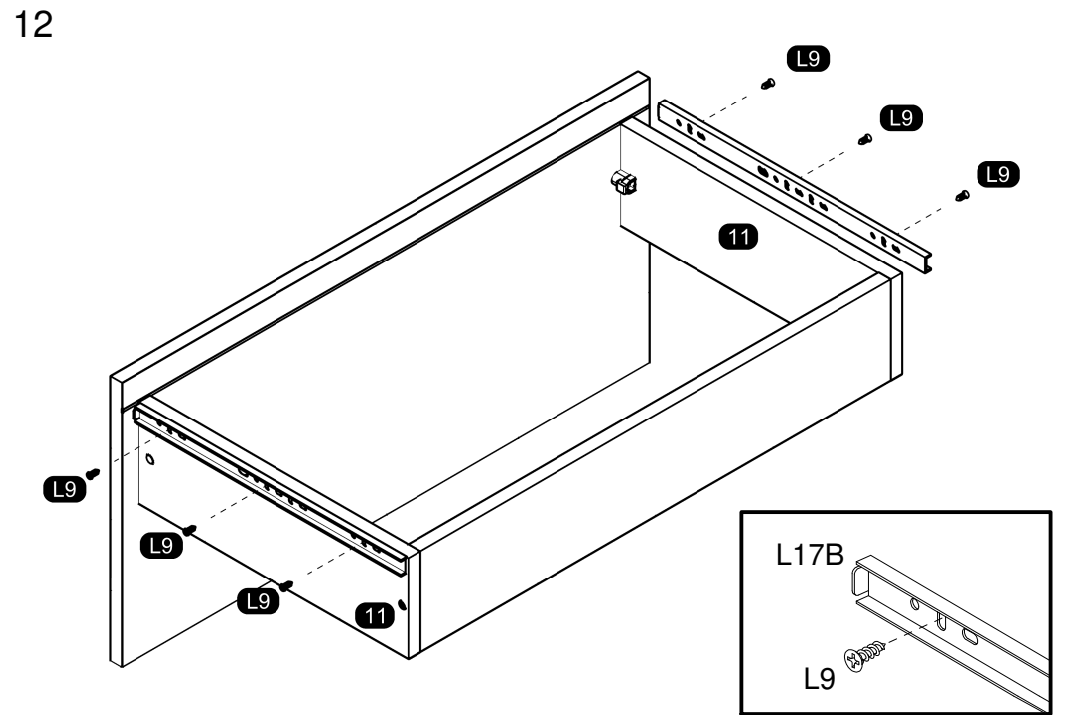
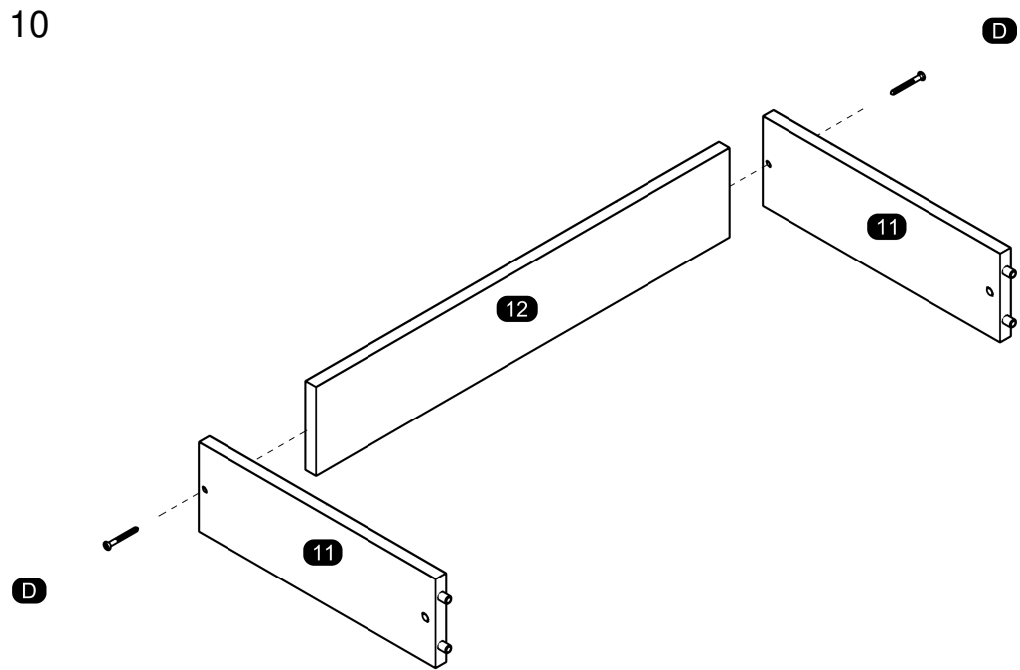

MOUNTING ON THE CHOSEN DRAWER FRONT MODEL
 MONTAGEM NO MODELO DE FRENTE DE GAVETA ESCOLHIDO / MONTAJE EN EL MODELO DE FRENTE DE CAJÓN ELEGIDO

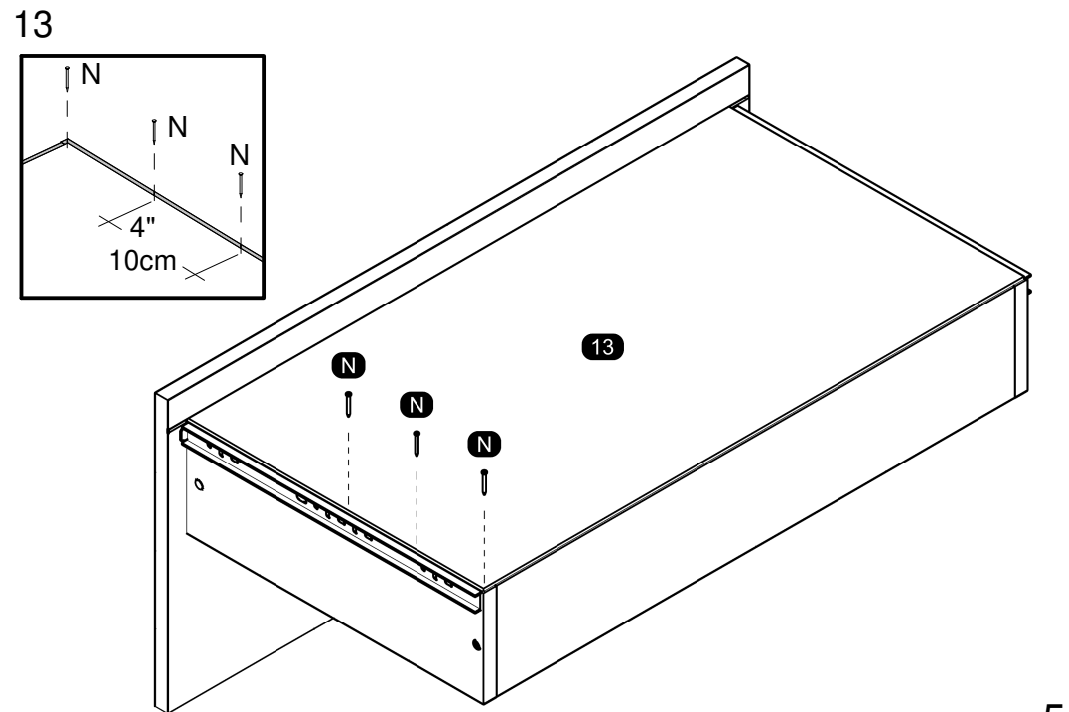
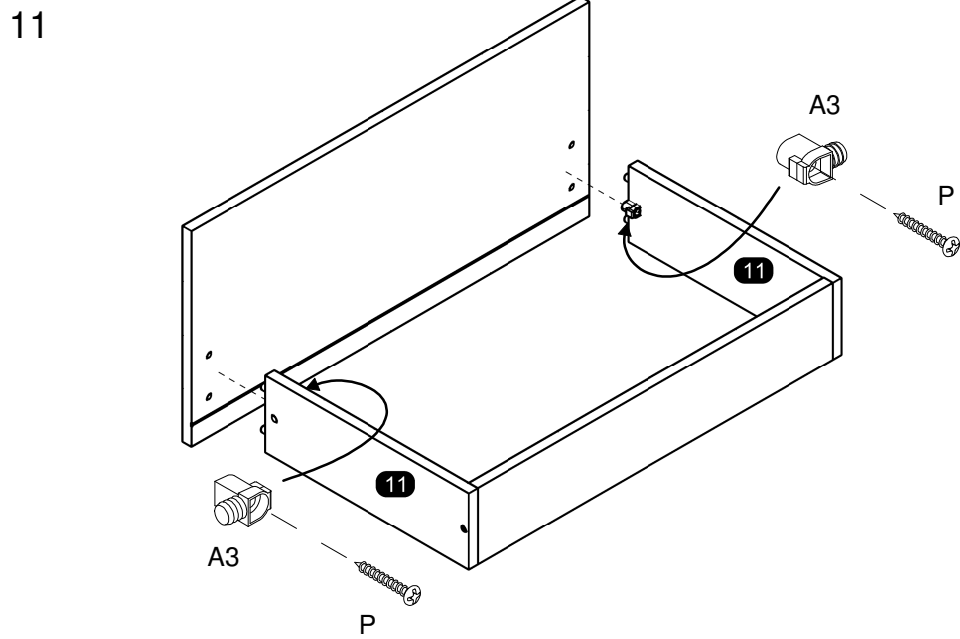

14

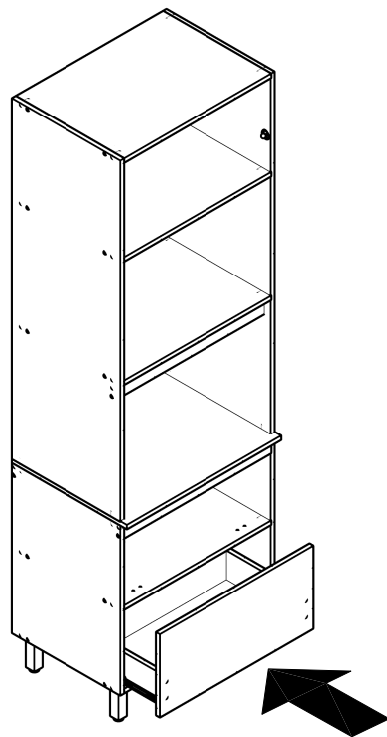

Drawer insertion
Inserção de gaveta
Inserción del cajón

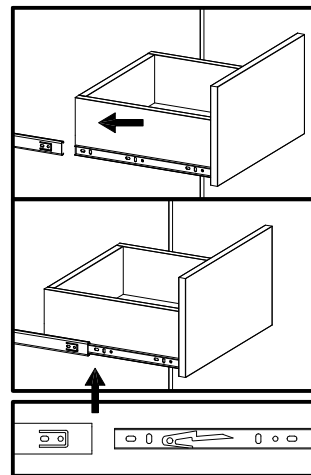

16

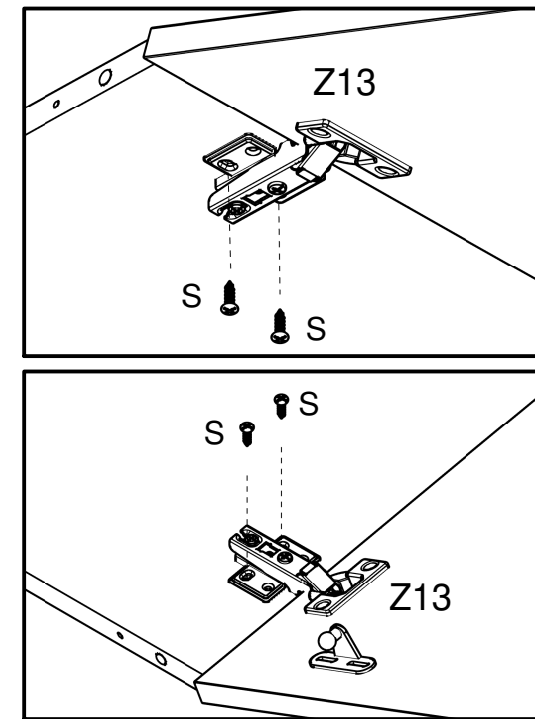
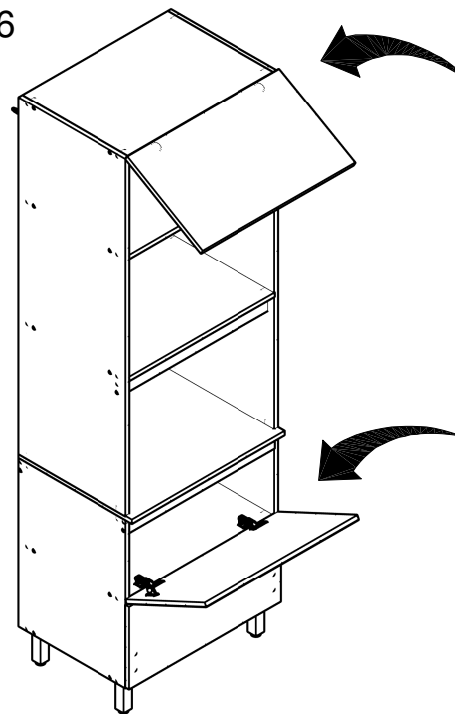

15

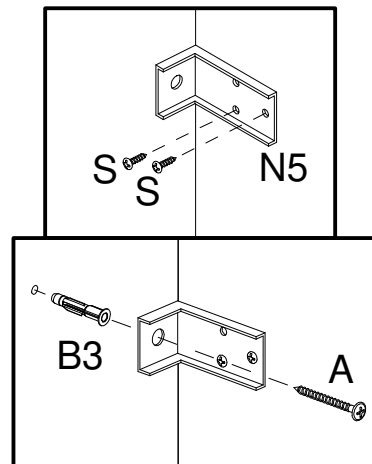
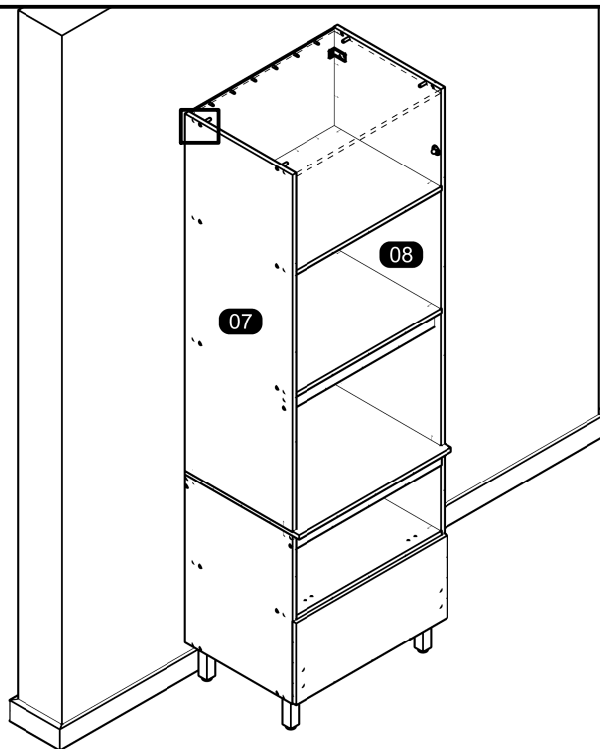

17

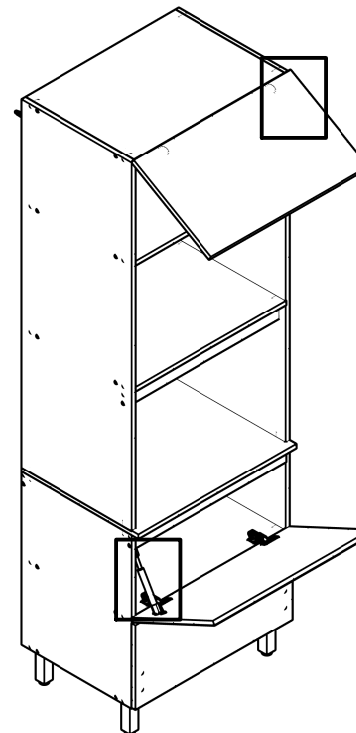

Follow the instruction corresponding to the template you received.
Siga a instrução correspondente ao modelo que recebeu.
Siga las instrucciones correspondientes al modelo que recibió.

Model 1 / Modelo 1

Model 2 / Modelo 2

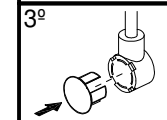
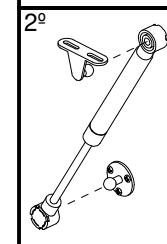
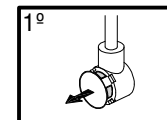
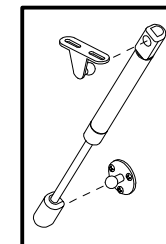

18

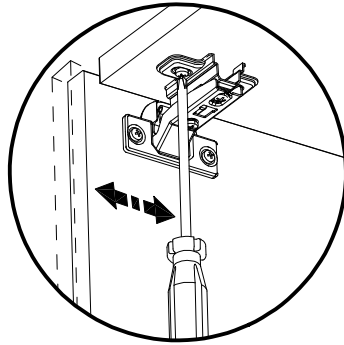
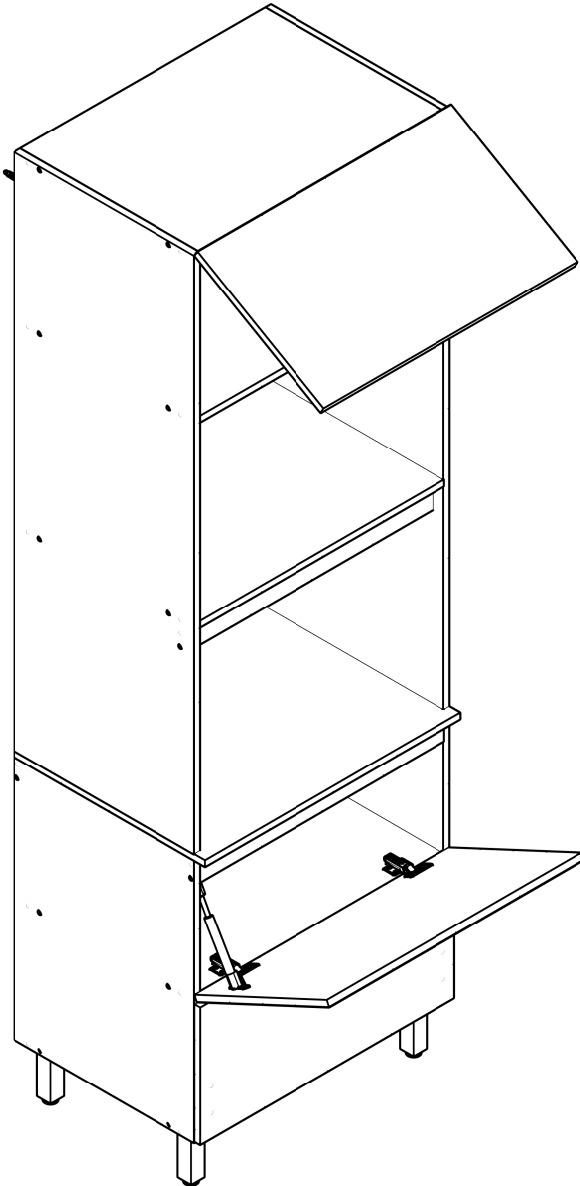
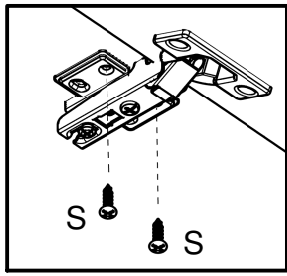

Horizontal Adjustment
Regulagem Horizontal
Ajuste Horizontal

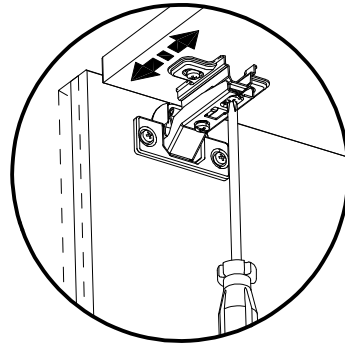

Depth Adjustment
Regulagem Profundidade
Ajuste Profundidad

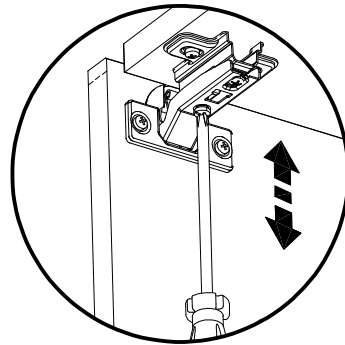

Vertical Adjustment
Regulagem Vertical
Ajuste Vertical

19

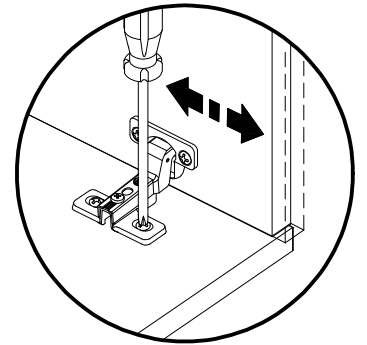
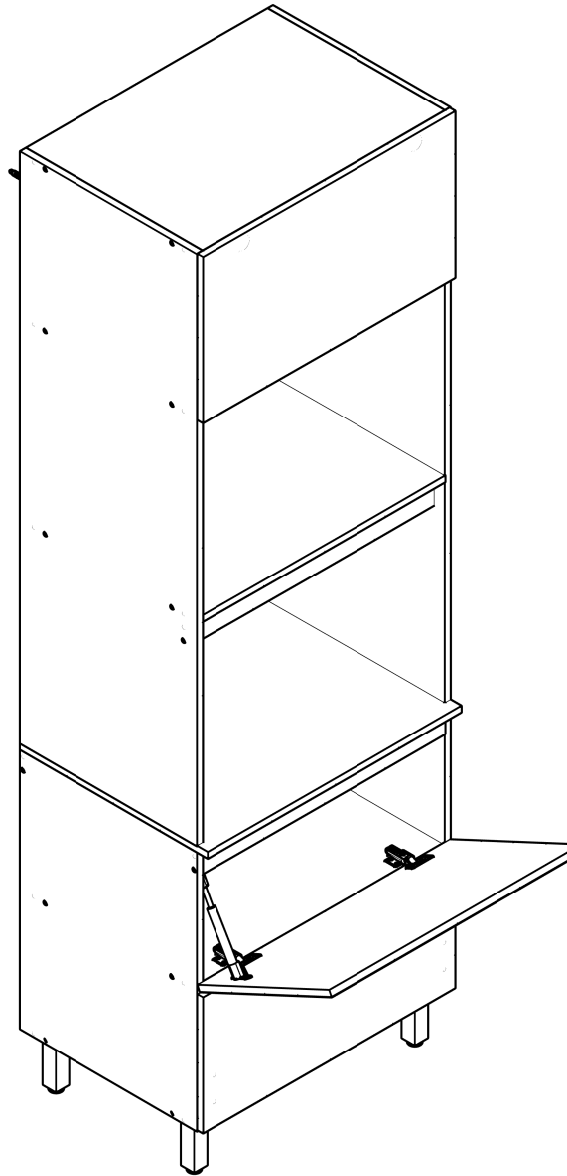

Horizontal Adjustment
Regulagem Horizontal
Ajuste Horizontal

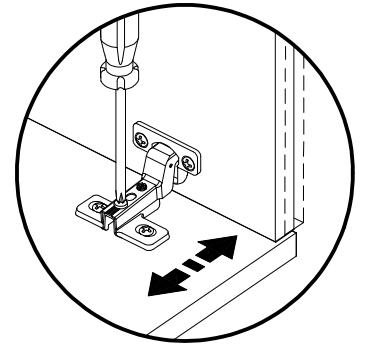

Depth Adjustment
Regulagem Profundidade
Ajuste Profundidad

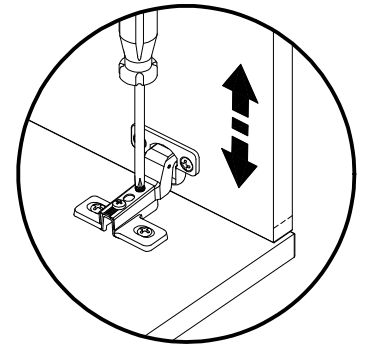

Vertical Adjustment
Regulagem Vertical
Ajuste Vertical

