

Instruções de Montagem

Instrucciones de Montage

Assembly Instructions

REF.

CZ-401

RD-4611

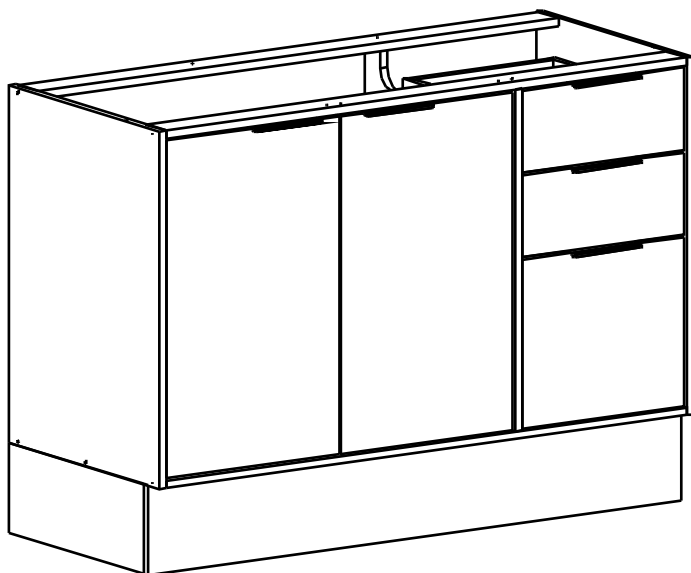
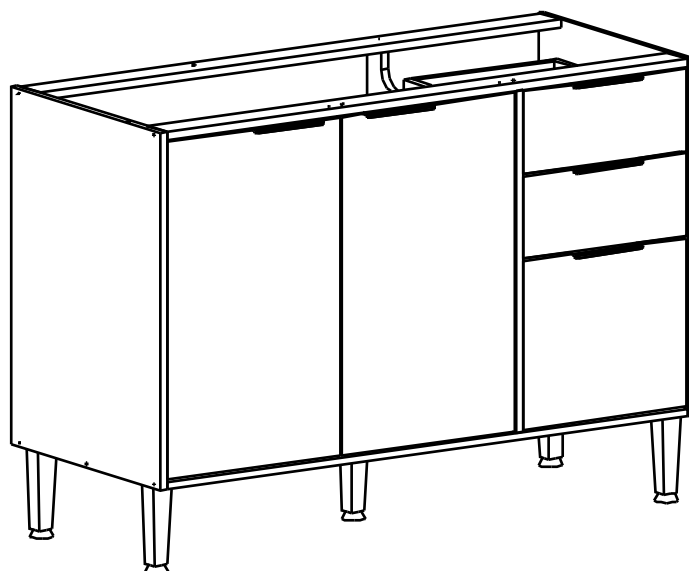

 **HECOL**
móveis

Rua Arlindo Baccin, 601 - Lot. Vinhedos,
Bento Gonçalves, RS - CEP: 95707-150

Fone: (54) 3454-5900

Email: contato@hecolmoveis.com.br

Site: www.hecolmoveis.com.br

LISTA DE PEÇAS

Nº PEÇA	CÓD. IND.	DESCRIÇÃO	QTD.	COMP. (mm)	LARG. (mm)	ESP. (mm)
01		Lateral Direita	1	680	500	MDP 15
02		Lateral Esquerda	1	680	500	MDP 15
03		Divisão	1	650	500	MDP 15
04		Base	1	1170	500	MDP 15
05		Prateleira	1	785	300	MDP 15
06		Lat Gav Maior Dir	1	400	170	MDP 15
07		Lat Gav Maior Esq	1	400	170	MDP 15
08		Lat Gav Menor Dir	2	400	100	MDP 15
09		Lat Gav Menor Esq	2	400	100	MDP 15
10		Costa de Gav Maior	1	314	170	MDP 15
11		Costa de Gav Menor	2	314	100	MDP 15
12		Frente de Gav Maior	1	364	319	MDP 15
13		Frente de Gav Menor	2	364	158	MDP 15
14		Porta	2	643	388	MDP 15
15		Travessa Frontal	1	1170	70	MDP 15
16		Travessa Traseira	1	1170	70	MDP 15
17		Fundo de gaveta	3	344	405	HDF 3
18		Costa	2	1190	332	HDF 3

LISTA DE PEÇAS PARA OPÇÃO COM RODAPÉ

19		Rodapé Frontal	1	1200	170	MDP 15
20		Rodapé Lateral	2	447	170	MDP 15

LISTA DE PEÇAS

Peças (19) e (20) somente na opção de montagem com rodapé.

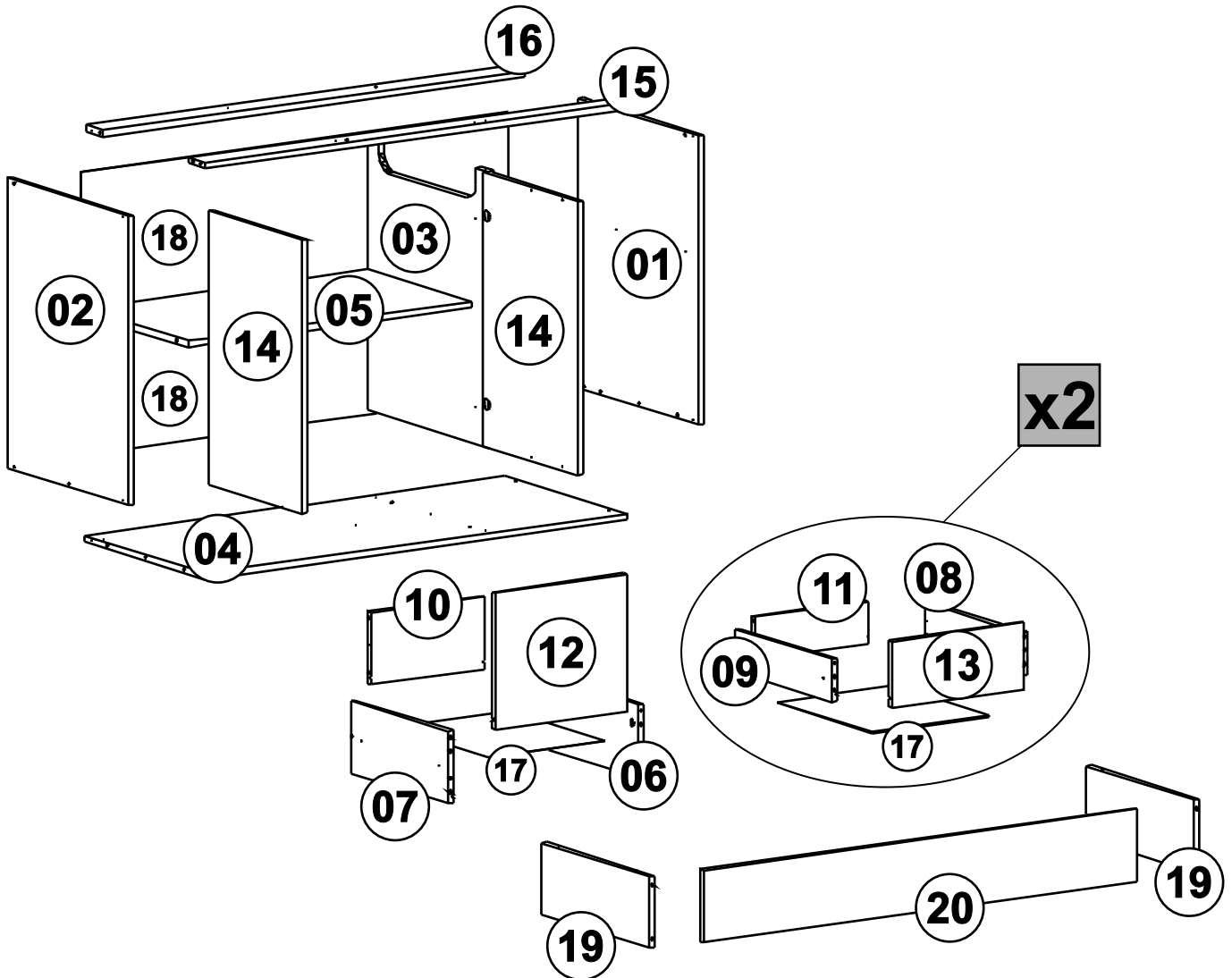

Para a montagem do produto você vai precisar de:

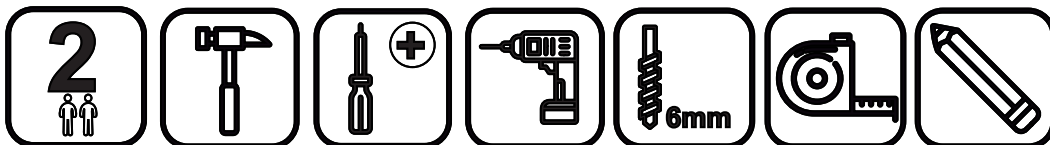









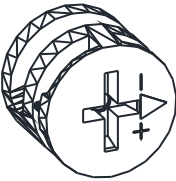

VERSÃO:
01

DATA:
17/10/25

ELABORADO POR:
Michel

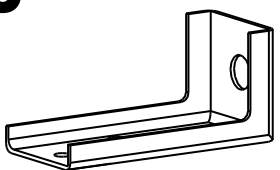
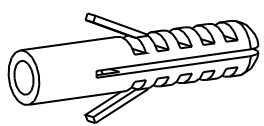
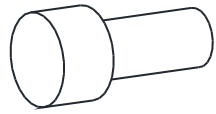
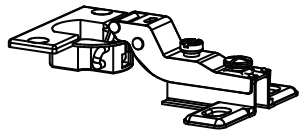
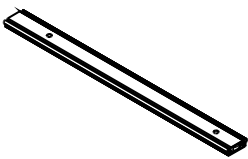
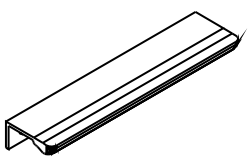
LISTA DE FERRAGEM

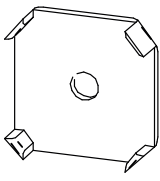
<p>A</p>  <p>x08</p> <p>Tambor Minifix 15x12mm</p>	<p>B</p>  <p>x08</p> <p>Parafuso Minifix</p>	<p>C</p>  <p>x26</p> <p>Parafuso 4,5x50mm CC</p>	<p>D</p>  <p>x04</p> <p>Parafuso 4,0x25mm CC</p>
<p>E</p>  <p>x24</p> <p>Parafuso 3,5x14mm CC</p>	<p>F</p>  <p>x02</p> <p>Parafuso 5x40mm CF</p>	<p>G</p>  <p>x28</p> <p>Parafuso 3,5x14mm CP</p>	<p>H</p>  <p>x38</p> <p>Cavilha 8x30mm</p>
<p>I</p>  <p>x80</p> <p>Prego 10x10</p>	<p>J</p>  <p>x02</p> <p>Suporte Aéreo Reforçado</p>	<p>K</p>  <p>x02</p> <p>Bucha 6x35mm</p>	<p>L</p>  <p>x02</p> <p>Pino Ø5x8mm</p>
<p>M</p>  <p>x04</p> <p>Dobra. Super-Curva Ø26mm</p>	<p>N</p>  <p>x03</p> <p>Corrediça Telesc. 400 mm</p>	<p>O</p>  <p>x05</p> <p>Puxador 128 mm Lisboa</p>	<p>P</p>  <p>x05</p> <p>Pé Cônico</p>
<p>Q</p>  <p>x06</p> <p>Garra Costa</p>	<p>OBS.: Item (D), parafuso 4,0x25cc usado somente para unir módulos, Ex: União dos MOD CZ-401 com CZ-404.</p>		

Use a régua abaixo para medir os componentes | Medida em mm
 Utilice la regla para medir los componentes | Medida en mm
 Use the ruler below to measure the components | Measured in mm

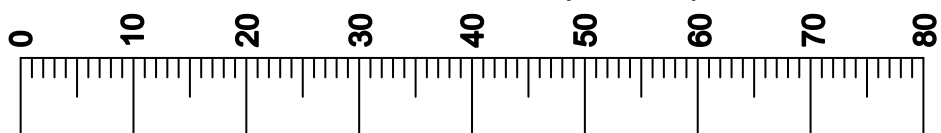

FERRAGEM PARA MONTAGEM DO RODAPÉ

R



x16

Parafuso 3,5x14mm CP

S



x08

Cavilha 8x30mm

T



x05

Prego 12x12

U

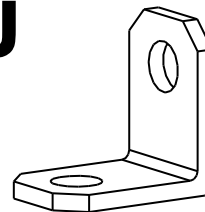

x08

Chapa "L" 20x20x12mm

V

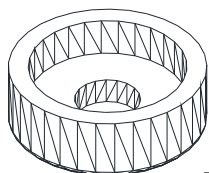

x05

Sapata

Importante:

Separar as duas partes das corredeiras (N),
Parte (1) Lateral do móvel;
Parte (2) Lateral da gaveta.

limportante:

Separe las dos partes de las guías (N):
Parte (1) Lateral del mueble;
Parte (2) Lateral del cajón.

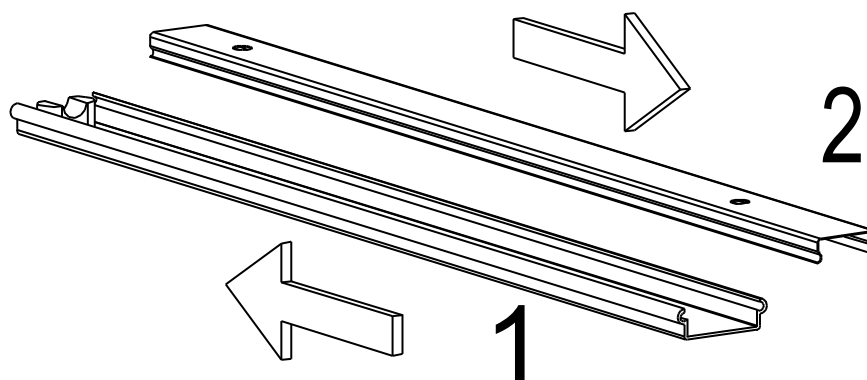

01

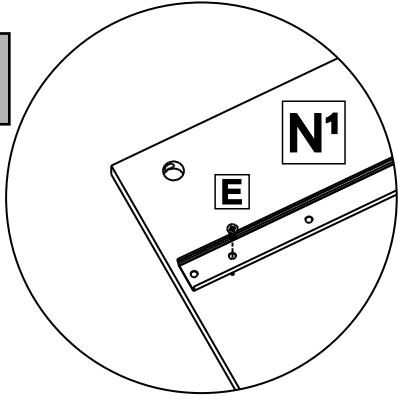

Fixar a corrediça (N 1) com parafuso (E) no segundo furo da corrediça na marcação.

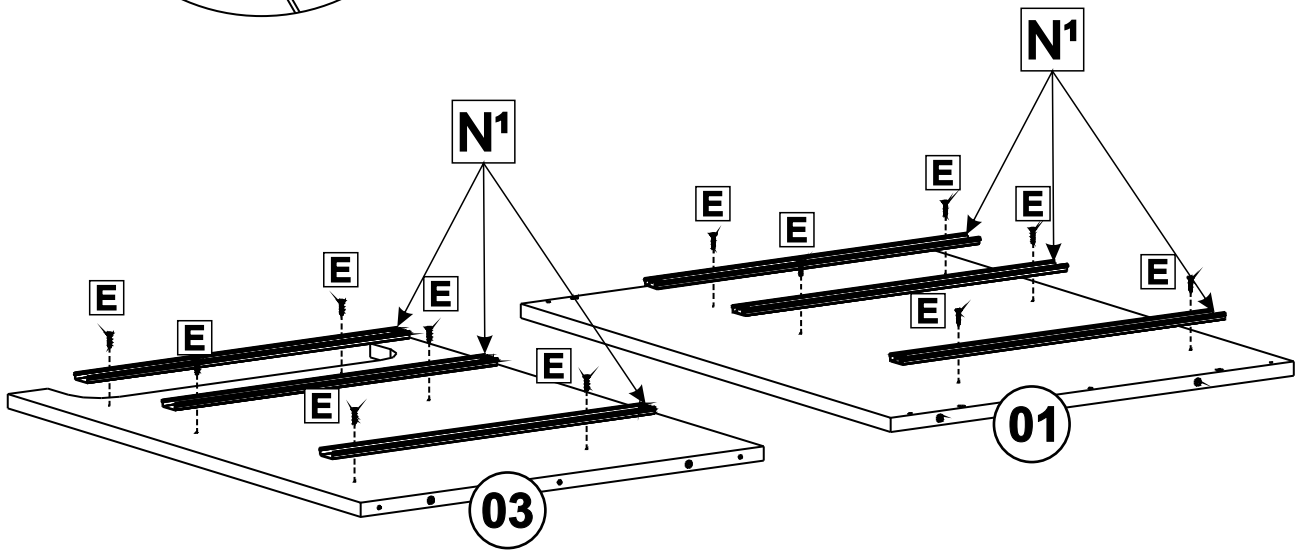

02

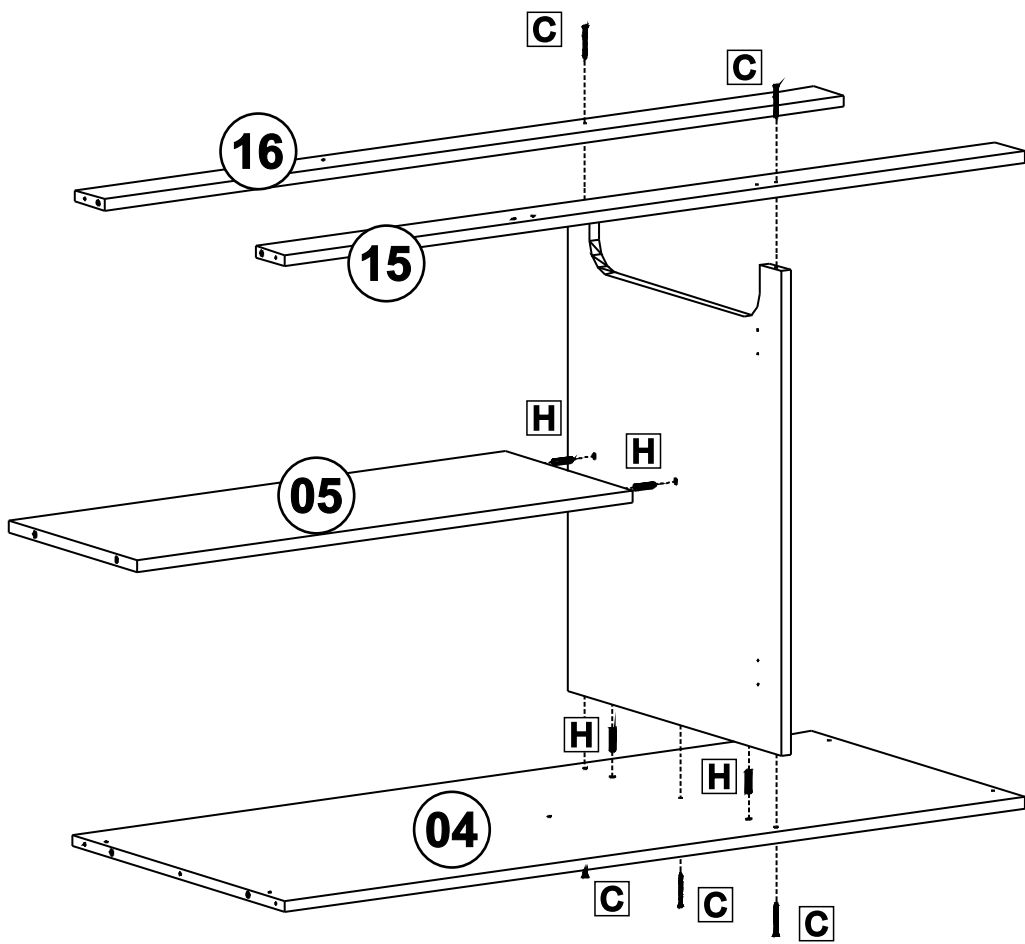

02

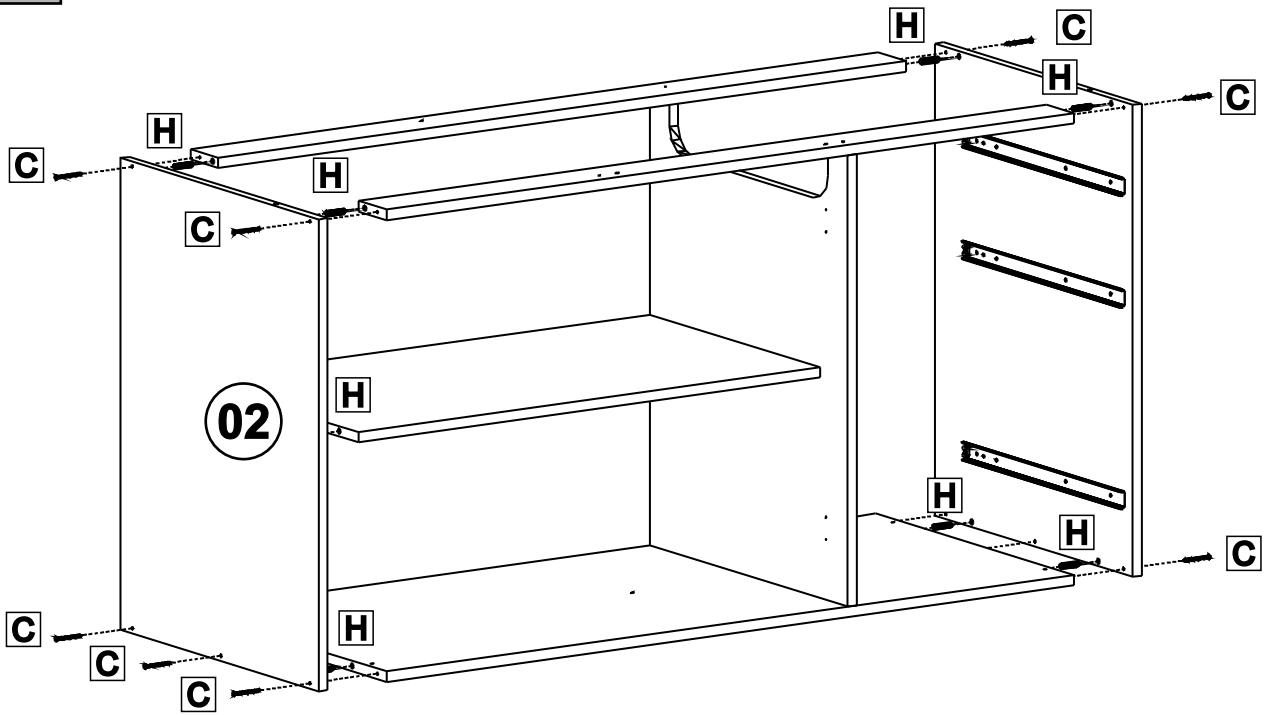

03

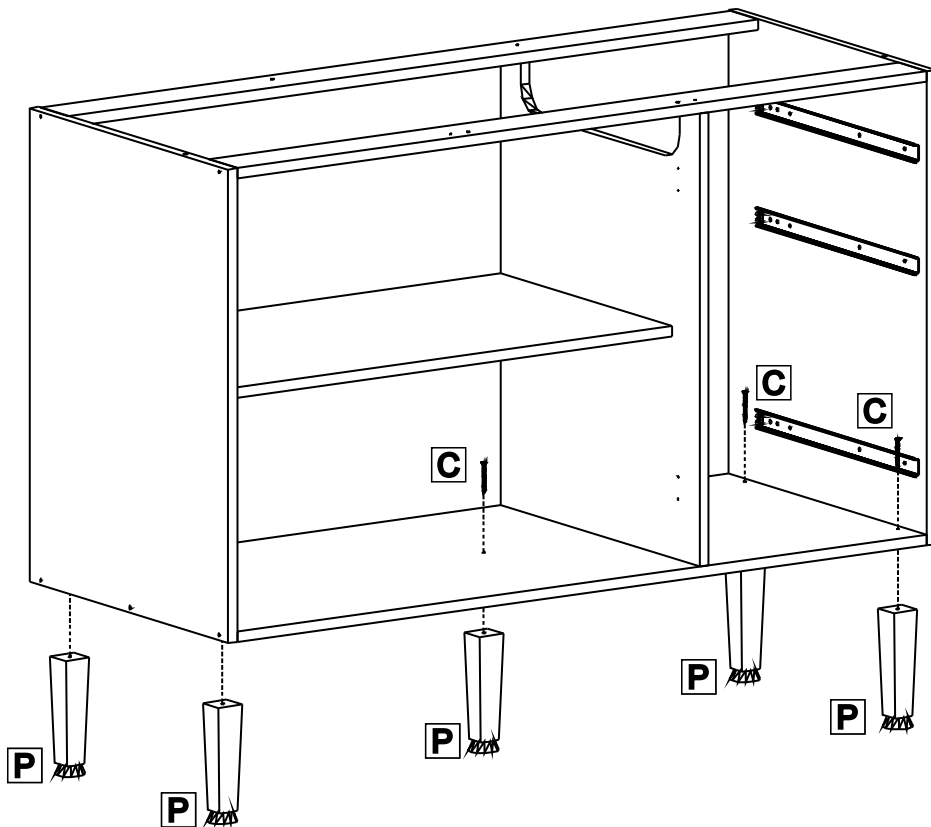

06

18

Q

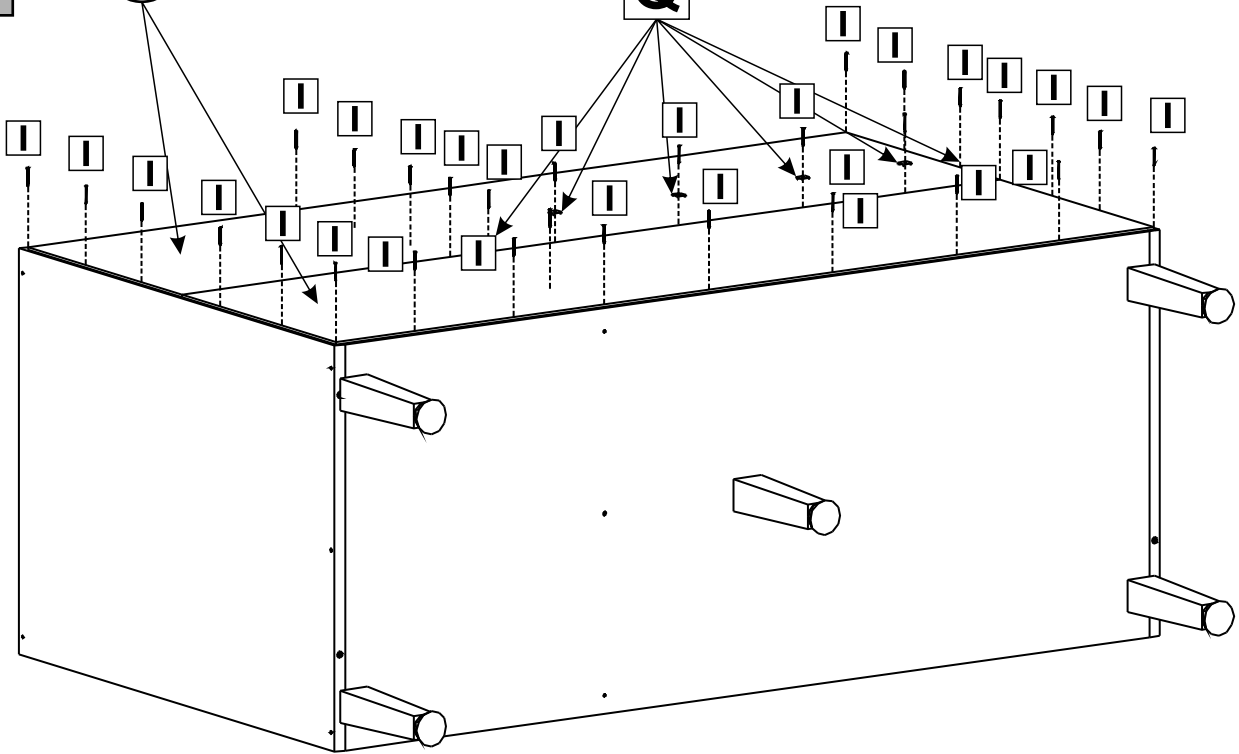

07

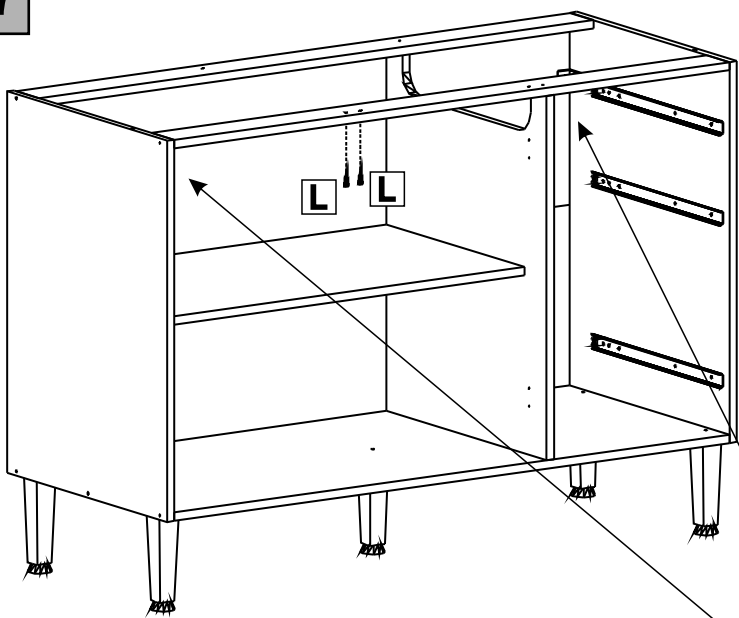

**RECOMENDA-SE
FIXAR O MÓVEL
NA PAREDE**

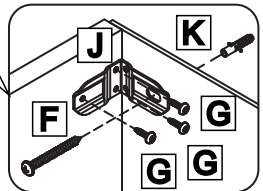

08

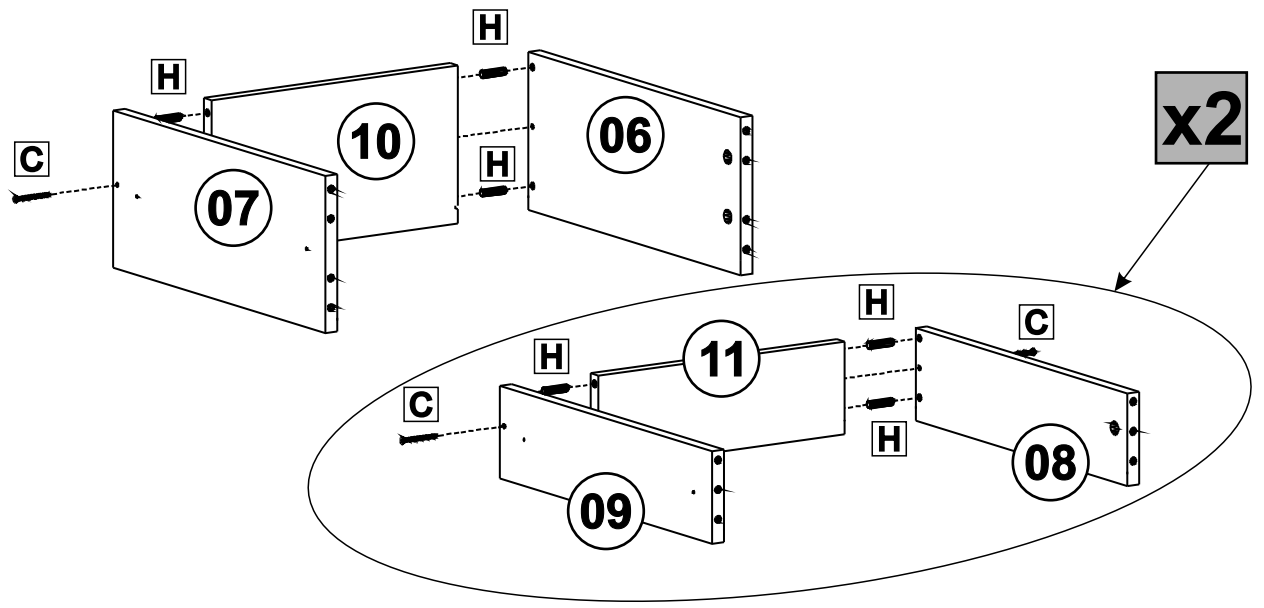

09

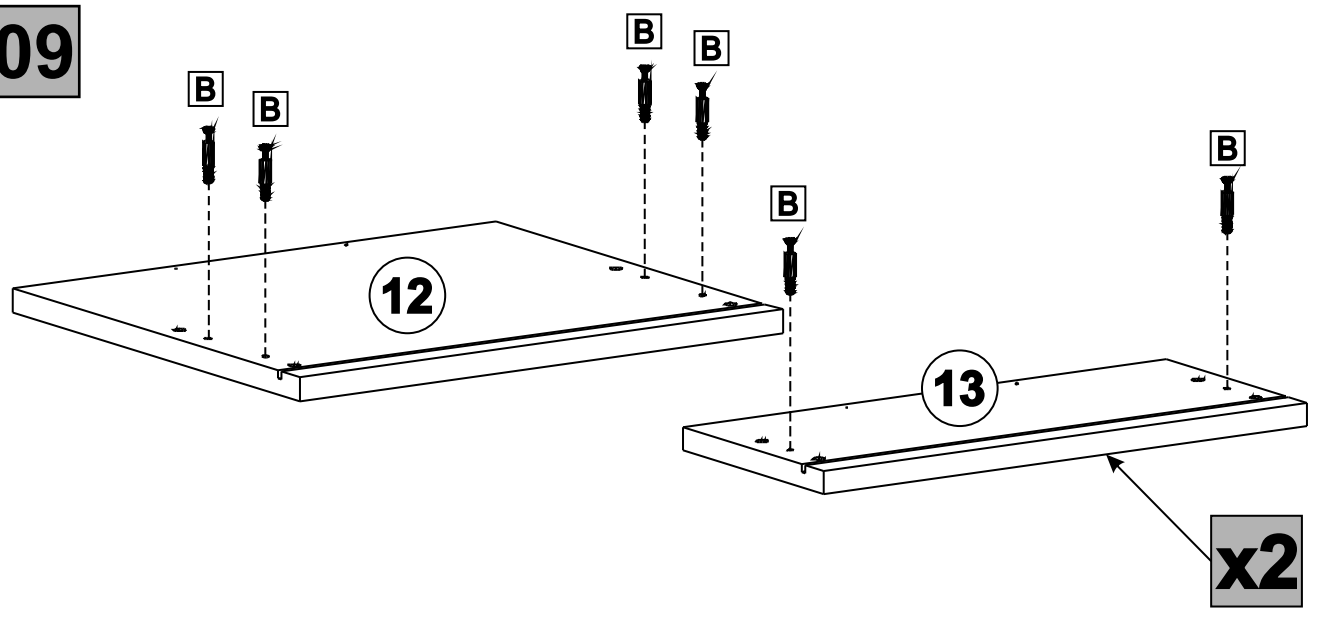

10

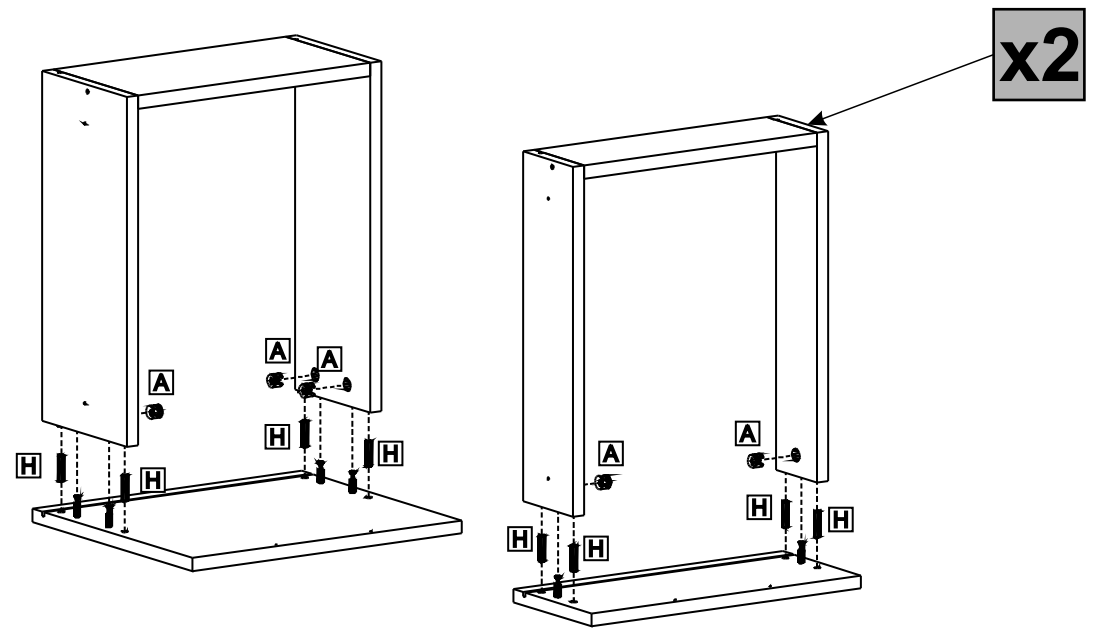

11

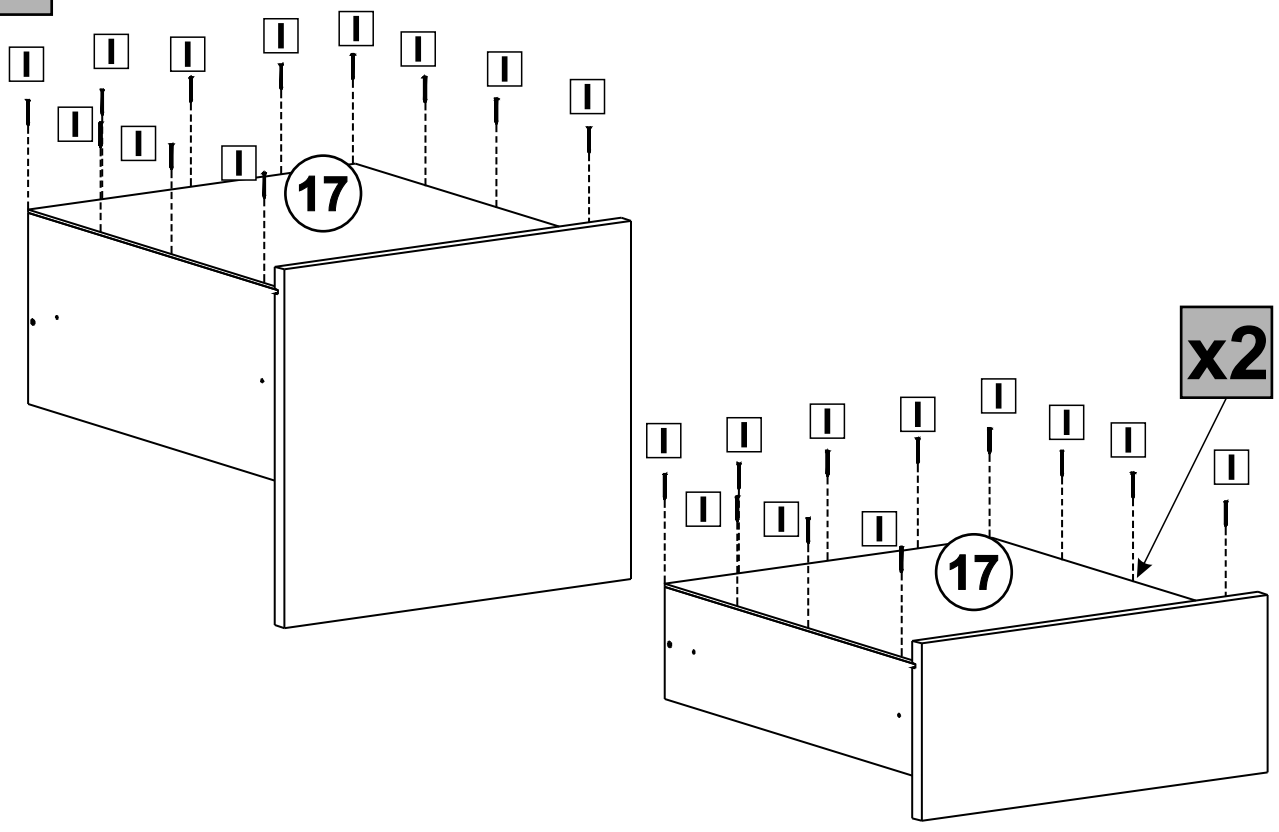

12

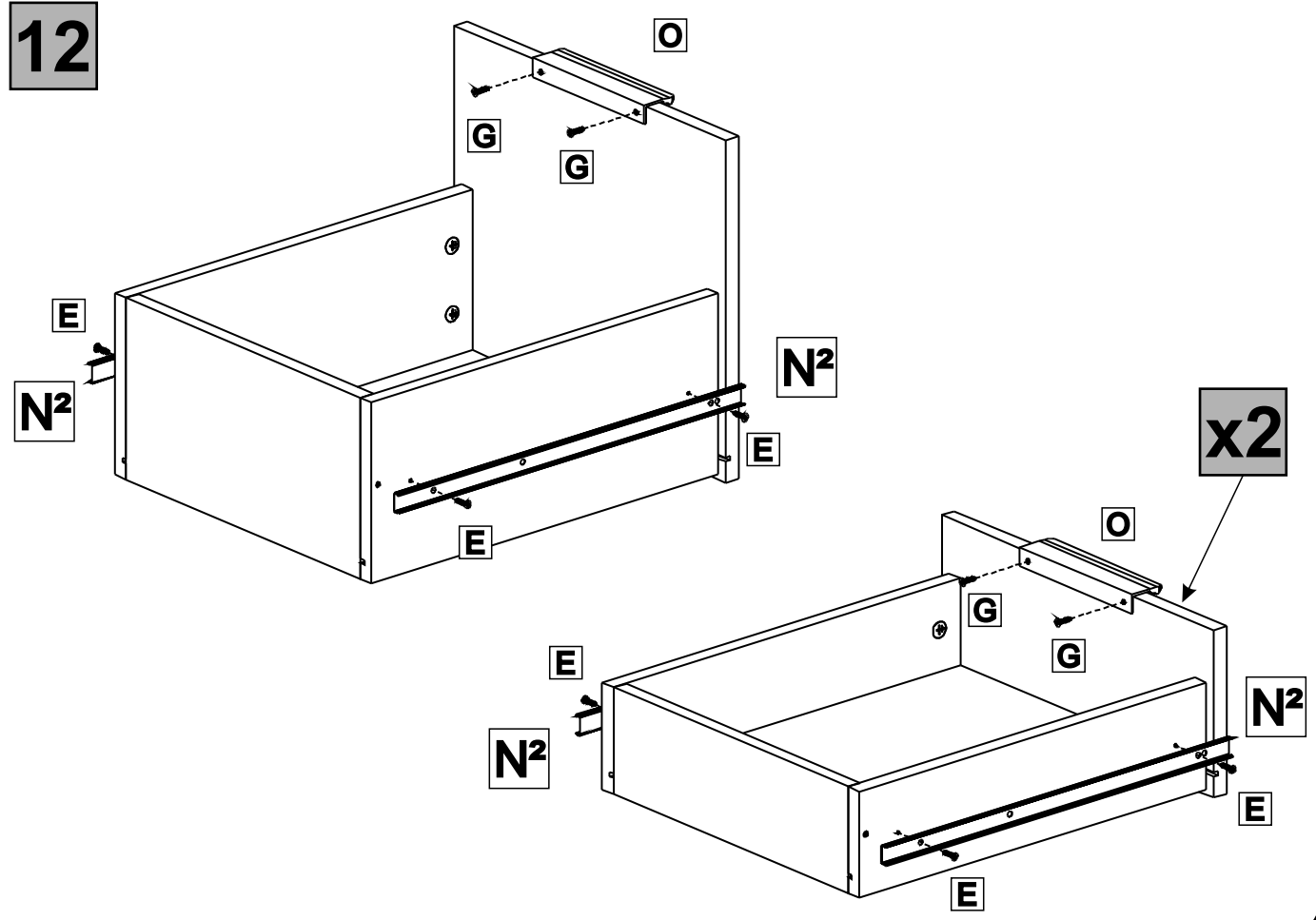

13

x2

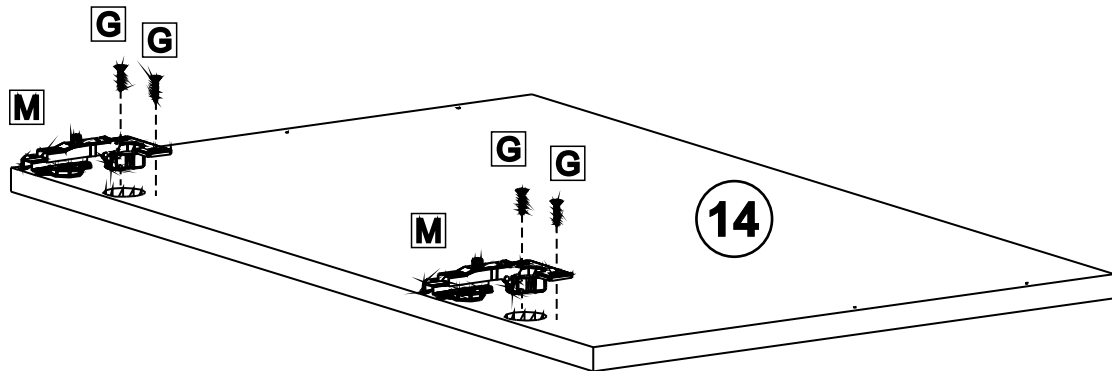

14

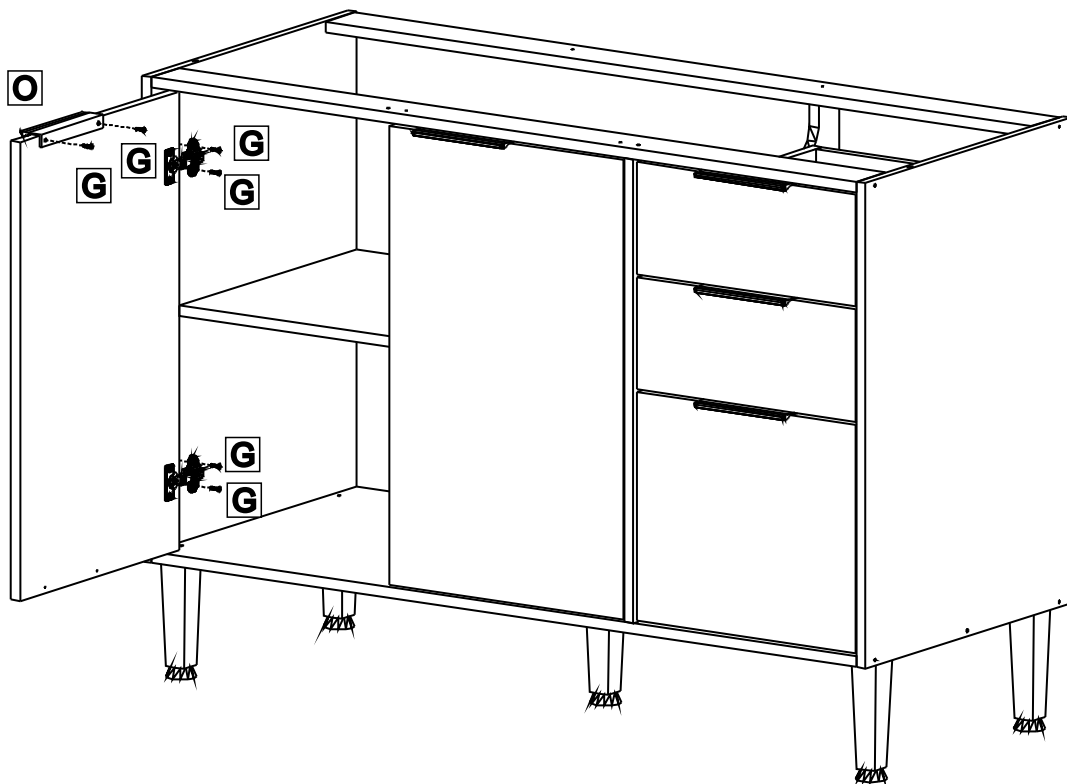

REGULAGEM DA PORTA

