

BALCAO CANTO 0.9M BLESS

V-0 30/03/2026

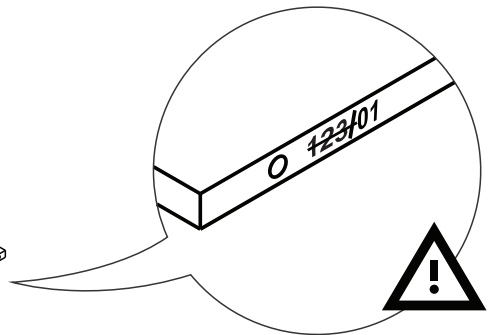
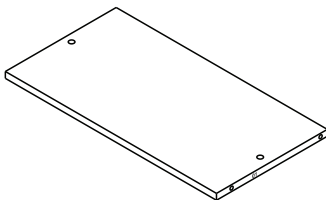
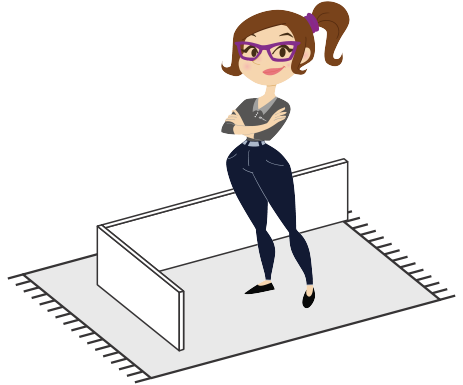
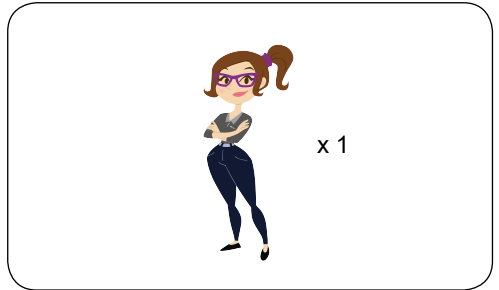
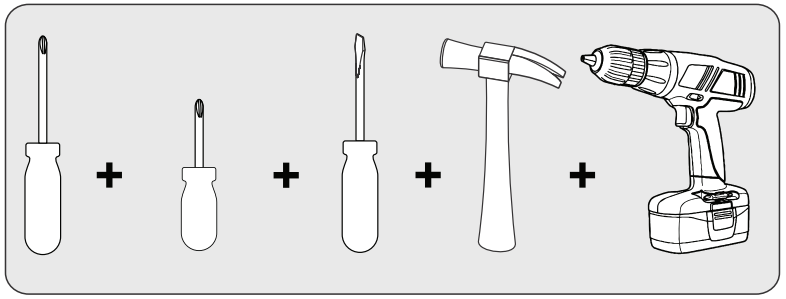
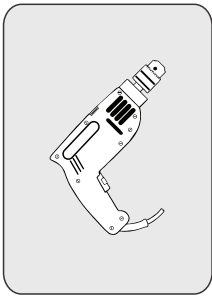

GARANTIA / GARANTIA / WARRANTY

Nossos produtos são garantidos por 90 dias contra defeitos de fabricação. Ao constatar um problema coberto pela garantia, entre em contato com a loja onde o produto foi comprado. Ela estará capacitada para atendê-lo da melhor forma diante de cada caso. Reclamações de garantia somente poderão ser atendidas se o termo de garantia for apresentado no ato de reivindicação, acompanhado de sua nota fiscal de compra.

Nuestros productos están garantidos contra defectos de fabricación por 90 días, a partir de la compra. Ao constatar un problema protegido por la garantía, póngase en contacto con la tienda donde se adquirió el producto. Ella estará capacitada para atenderlo de la mejor manera de acuerdo con cada caso.

Our products are guaranteed against manufacturing defects for 90 days from the date of purchase. When you find a problem covered by the warranty, please contact the store where the product was purchased. The store be able to serve you in the best way in each case.

Exclusões

- Desgaste natural ou danos causados por água, maresia, ferrugem, incêndio, calor, cupins e pragas em geral.
- Montagem, manutenção e uso inadequado.
- Não cumprimento das recomendações técnicas do esquema.
- Montagens e desmontagens após a primeira instalação.
- Instalações elétricas e outras afins.

Exclusiones

- *Desgaste natural o daños causados por agua, mares, maresia, incendios, calor, termitas y plagas en general.*
- *Montaje, mantenimiento y uso inadecuado.*
- *No cumplimiento de las recomendaciones técnicas del esquema.*

Exclusions

- *Natural wear or damage caused by water, sea, rust, fire, heat, termites and plagues in general.*
- *Assembly, maintenance and improper use.*
- *Failure to comply with the technical recommendations of the assembly instructions.*

Importante

A fabricante reserva-se no direito de efetuar nos produtos eventuais modificações que considerar necessárias, sem prejudicar as características essenciais. Os produtos terão peças de assistência para reposição no período de 1 ano a contar de sua retirada do mercado, desde que haja matéria-prima equivalente, observando o dispositivo no Art.32 da Lei 8.078/90 (Cód. Defesa do Consumidor). O atendimento para produtos fora de linha é feito por programação especial, através da loja revendedora sob aprovação de consulta prévia ao fabricante.

Importante

El fabricante se reserva el derecho de efectuar en los productos eventuales modificaciones que considere necesarias, sin perjudicar las características esenciales. Los productos tendrán piezas de asistencia para reposición en el periodo de 1 año a partir de su retirada del mercado. La atención para productos fuera de línea es hecha por programación especial, a través de la tienda revendedora bajo aprobación de consulta previa al fabricante.

Important

The manufacturer reserves the right to make in the products any modifications that it considers necessary without prejudice to the essential characteristics. The products will have replacement parts within one year of being withdrawn from the market, the service for off-line products is done by special programming, through the store reseller under prior consultation with the manufacturer.

INSTRUÇÕES DE LIMPEZA E CONSERVAÇÃO

INSTRUCCIONES PARA LA LIMPIEZA E CONSERVACION / CLEAN AND PRESERVATION INSTRUCTURE

Para retirar o pó, utilize um pano seco, espanador ou aspirador. Se necessário, para uma limpeza mais efetiva, utilize um pano levemente umedecido com água. Finalize com uma flanela limpa e seca.

Para eliminar el polvo, utilice un paño seco, mopa o la aspiradora. Si es necesario, para una limpieza más eficaz, utilice un paño ligeramente humedecido con agua. Terminar con un paño limpio y seco.

To take dirty, use a dry cloth, duster or vacuum. If necessary to take the dust, use a wet cloth. Finish with a clean and dry flannel.

IMPORTANTE / IMPORTANTE / IMPORTANT

 Não utilize produtos abrasivos como álcool e detergentes, como também esponjas rígidas ou palha de aço na limpeza dos móveis. *No use limpiadores abrasivos como alcohol y detergentes, así como esponjas rígidas o lana de acero para limpiar los muebles.*
Do not use abrasives such as alcohol and detergent, tough soaker also steel wool to clean the furniture.

 Proteja a superfície do móvel de objetos que transmitam calor ou umidade. *Proteja la superficie del mueble de objetos que transmitan calor o humedad.*
Protect the surface of the furniture against objects that can pass heat and humidity.

 Evitar o contato de água e produto de limpeza com o rodapé do produto, pois poderá danificá-lo. *Evitar el contacto con agua y producto de limpieza con el rodapé del producto, pues podrá dañarlo.*
Avoid the contact of water and cleaning products with baseboard, cause it should damage your product.

 Procure sempre utilizar flanela limpa e seca para a limpeza. *Busque siempre utilizar flanela limpia y seca para la limpieza.*
Try always to use a clean and dry flannel to cleaning.

 Cuidado com objetos pontiagudos, eles podem arranhar a superfície das portas e tampo. *Cuidado con objetos afilados, ellos pueden rayar la superficie de las puertas e la tapa.*
Take care with sharp objects, they can scratch the door lid surface.

Imagem Ilustrativa/ Illustrative Image/ Imagen Ilustrativa



Preste Atenção! ¡Preste atención! Attention!

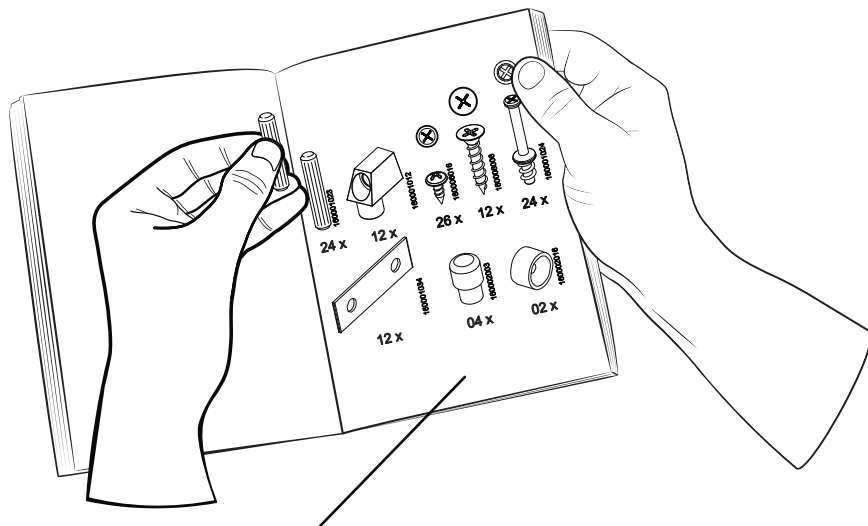

As ferragens dos nossos manuais são sempre apresentadas nas mesmas proporções da peça na vida real. Caso apareça alguma dúvida no decorrer do processo de montagem, coloque a ferragem ao lado do desenho e faça a consulta. :D

Los accesorios de nuestros manuales siempre se presentan en las mismas proporciones que la pieza en la vida real. Si tiene alguna duda durante el proceso de montaje, coloque los accesorios junto al dibujo y haga una consulta. :D

The accessories in our manuals are always presented in the same proportions as the spare part in real life. If you have any questions during the assembly process, place the accessory next to the drawing and make an inquiry. :D

Símbolos: Simbolos: Symbols:



- + Parafuso Phillips
- Parafuso Fenda
- Parafuso Allen

- + Tomillo Phillips
- Tomillo Ranurado
- Tomillo Allen

- + Phillips screw
- Slotted Screw
- Allenscrew

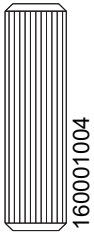

18x

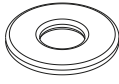

02x

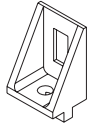

03x

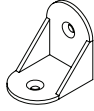

14 x



02x



02x

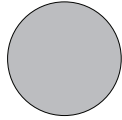

24x

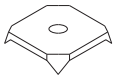

08x

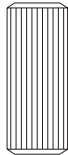

04x

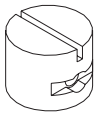

04 x

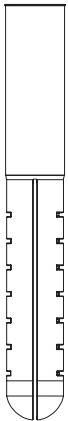

02x



14x



08x



35x



02x



55x



02x



10x

1:1

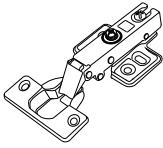

160003014

02x



160009047

04x

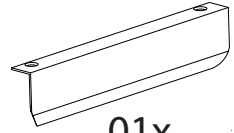

160005089

01x

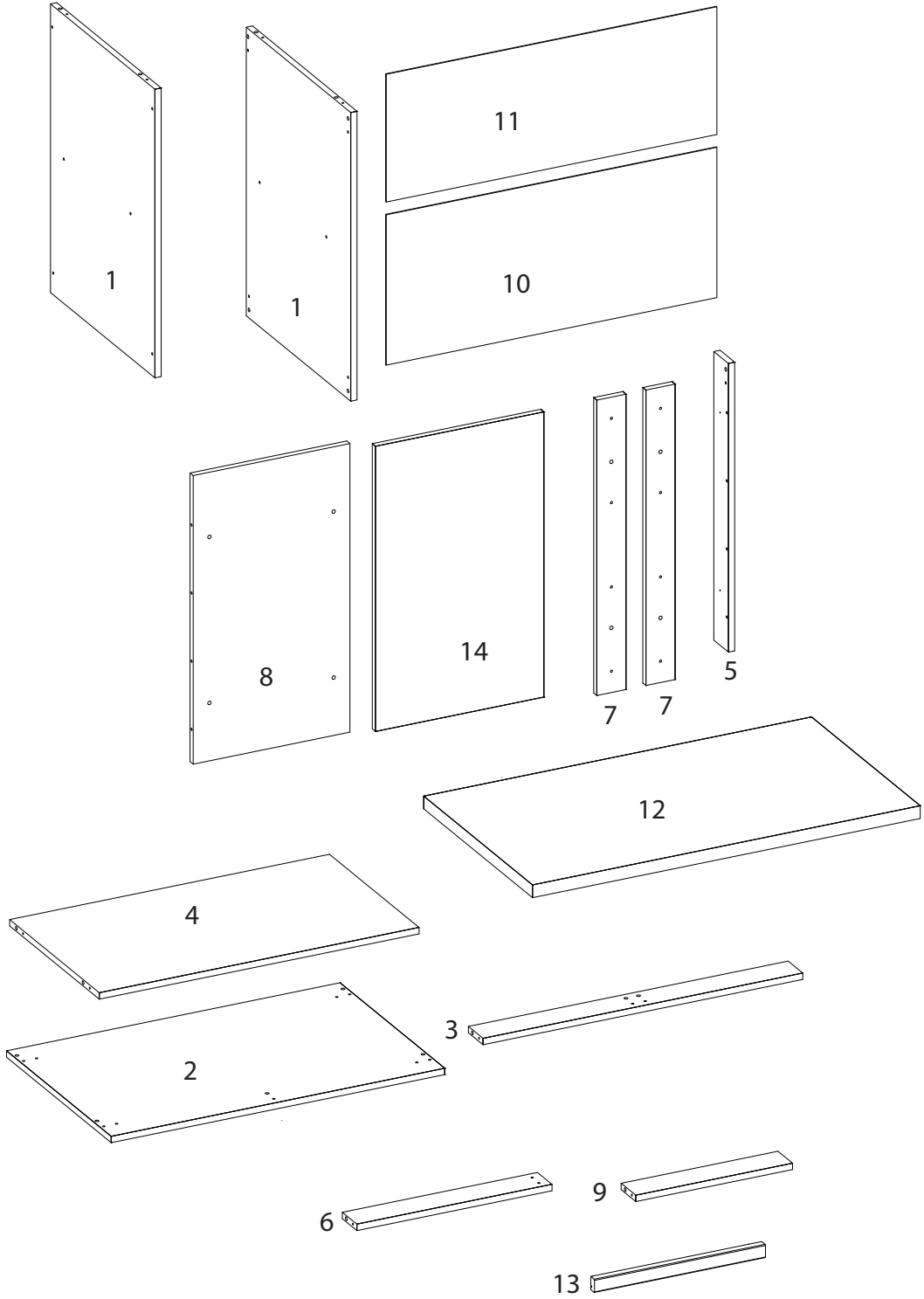

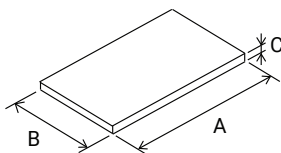

VOLUME Caja BOX	ITEM Artículo Item	PEÇA Pieza Part	DESCRIÇÃO Descripción Description	DIMENSÕES (mm) Dimensión/Dimension			QUANTIDADE Cantidad Amount	Material
				A	B	C		
1	1	510553001	LATERAL	678	501	15	2	MDF
1	2	510553002	BASE	800	502	15	1	MDF
1	3	510553003	TRAVESSA TRASEIRA	767	70	15	1	MDF
1	4	510553004	PRATELEIRA	767	430	15	1	MDF
1	5	510553005	BATENTE PORTA	678	70	15	1	MDF
1	6	510553006	TRAVESSA CENTRAL	465	70	15	1	MDF
1	7	510553007	TRAVESSA FRONTAL	694	70	15	2	MDF
1	8	510553008	PAINEL FRONTAL	678	376	15	1	MDF
1	9	510553009	VISTA FRONTAL	376	70	15	1	MDF
1	10	510553010	FUNDO INFERIOR	793	353	2.8	1	MDF
1	11	510553011	FUNDO SUPERIOR	793	300	2.8	1	MDF
1	12	510553012	TAMPO ENGRESSADO	930	522	30	1	MDF
1	13	510553013	ENCABECAMENTO	410	31	18	1	MDF
1	14	510553014	PORTA	670	404	15	1	MDF

ITEM	DESCRIPTION	ARTÍCULO	DESCRIPCIÓN
1	SIDE	1	LATERAL
2	BASE	2	BASE
3	REAR CROSSBAR	3	TRAVESAÑO TRASERO
4	SHELF	4	ESTANTE
5	DOOR STOP	5	TOPE DE PUERTA
6	CENTRAL CROSSBAR	6	TRAVESAÑO CENTRAL
7	FRONT CROSSBAR	7	TRAVESAÑO DELANTERO
8	FRONT PANEL	8	PANEL FRONTAL
9	FRONT VIEW	9	VISTA FRONTAL
10	LOWER BACK PANEL	10	PANEL TRASERO INFERIOR
11	UPPER BACK PANEL	11	PANEL TRASERO SUPERIOR
12	THICKENED TOP	12	PARTE SUPERIOR ENGRESSADA
13	HEAD PANEL	13	PANEL CABECERO
14	DOOR	14	PUERTA

01

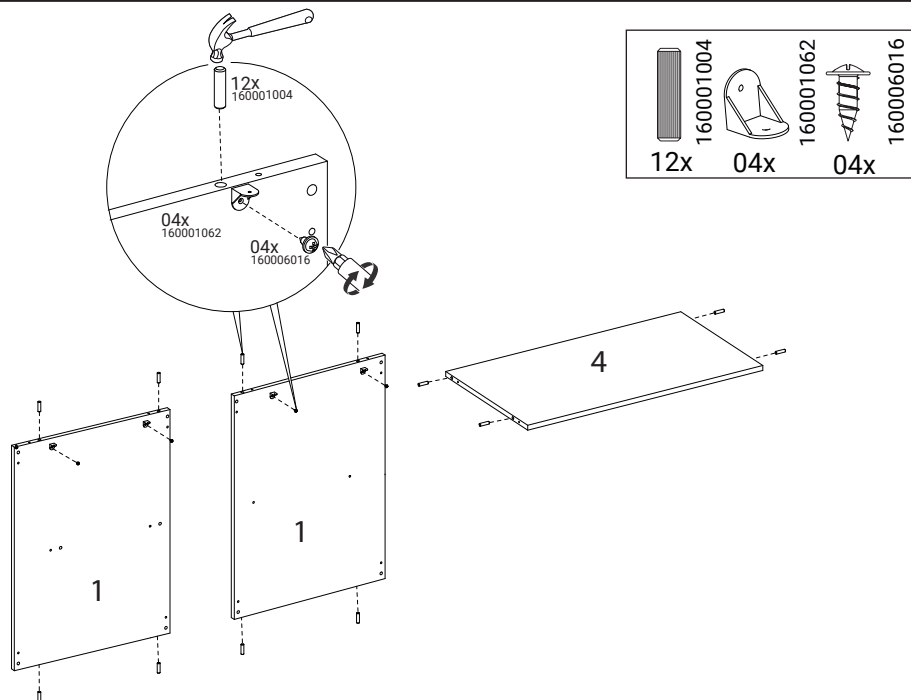

02

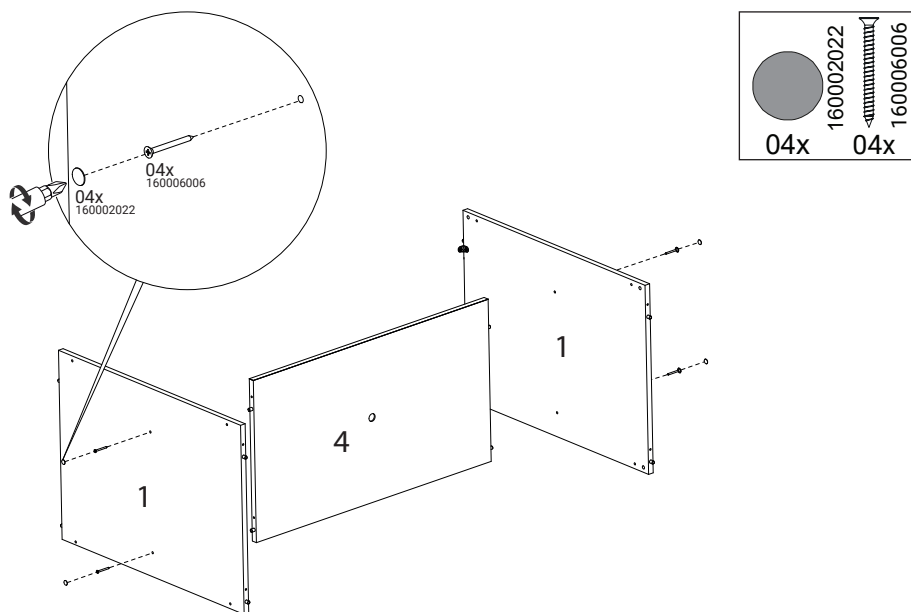

03

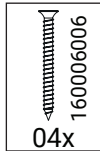
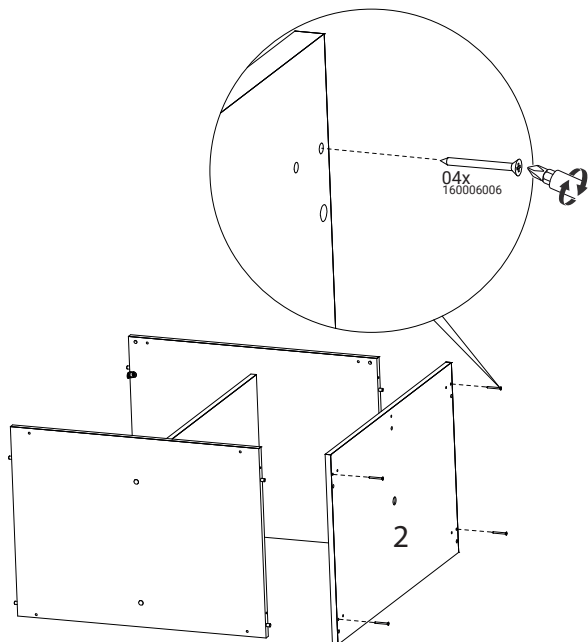

04

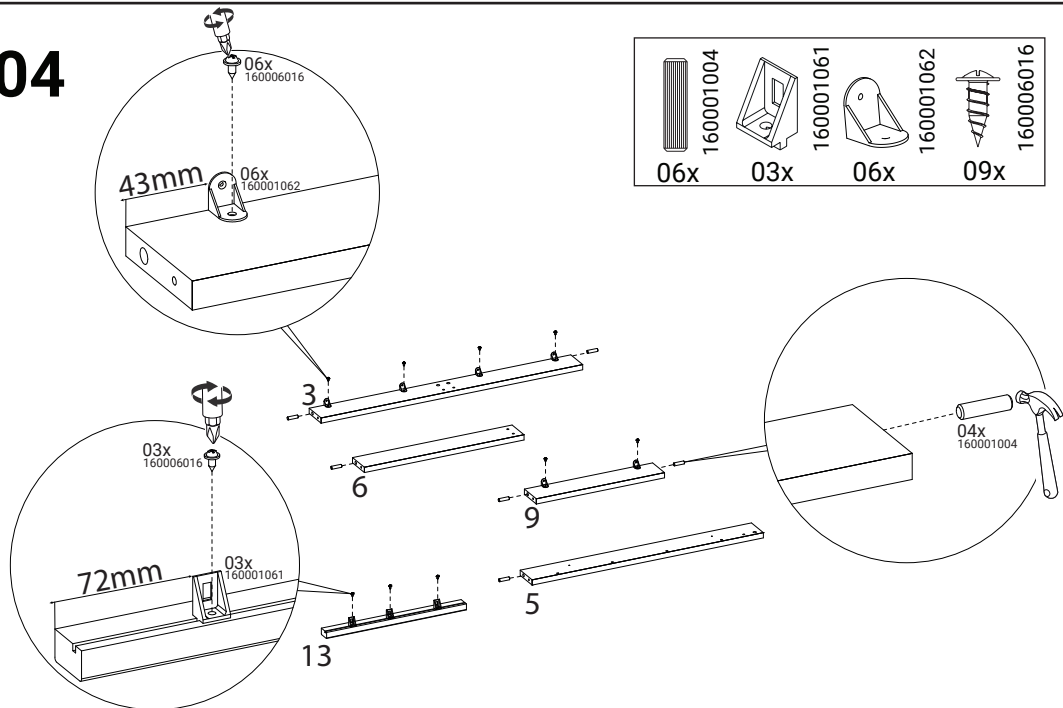

**Para montar a porta do lado direito, vá para o passo
05-A.**



Para montar la puerta del lado derecho, vaya al paso 05-A.
To install the door on the right side, go to step 05-A.

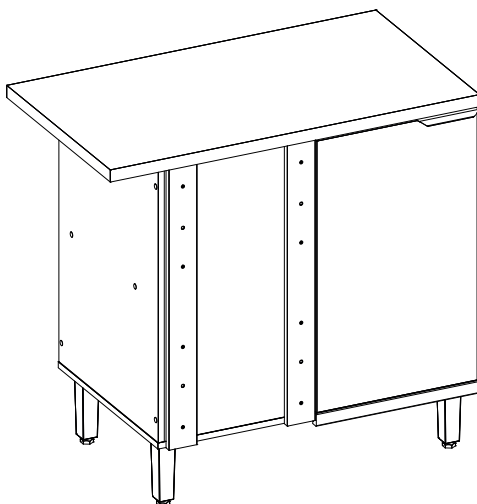

**Para montar a porta do lado esquerdo, vá para o
passo 05-B.**



Para montar la puerta del lado izquierdo, vaya al paso 05-B.
To install the door on the left side, go to step 05-B.

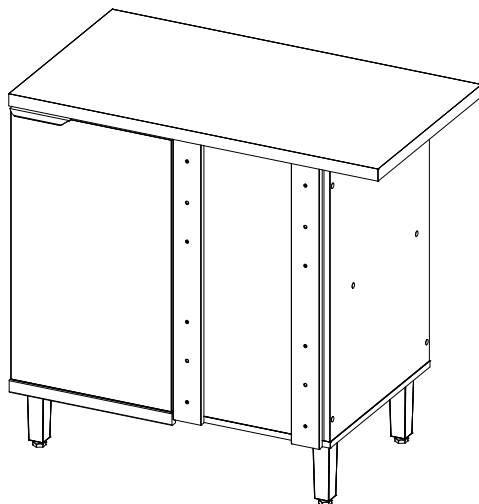

05-A

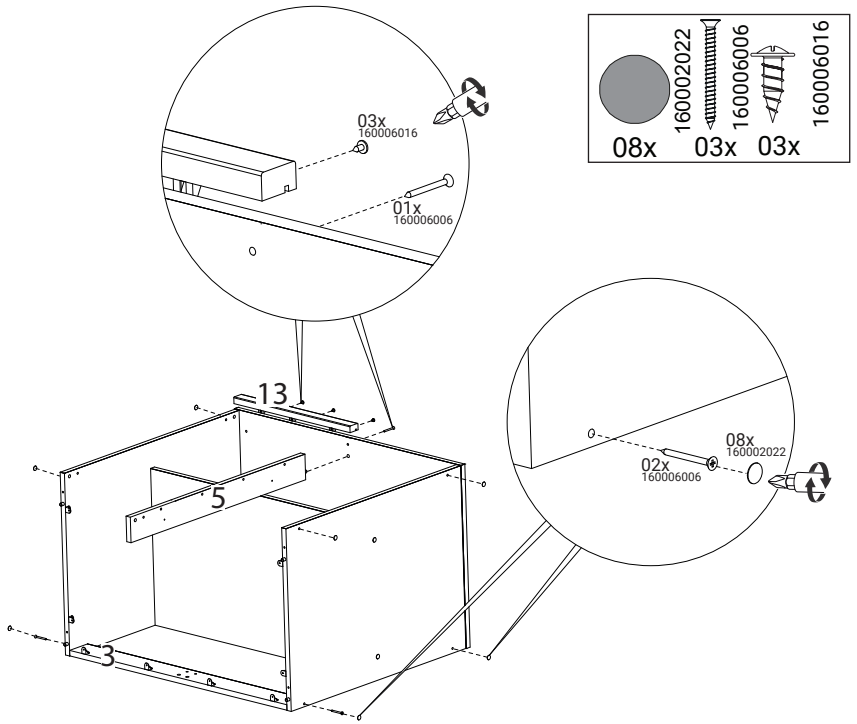

06-A

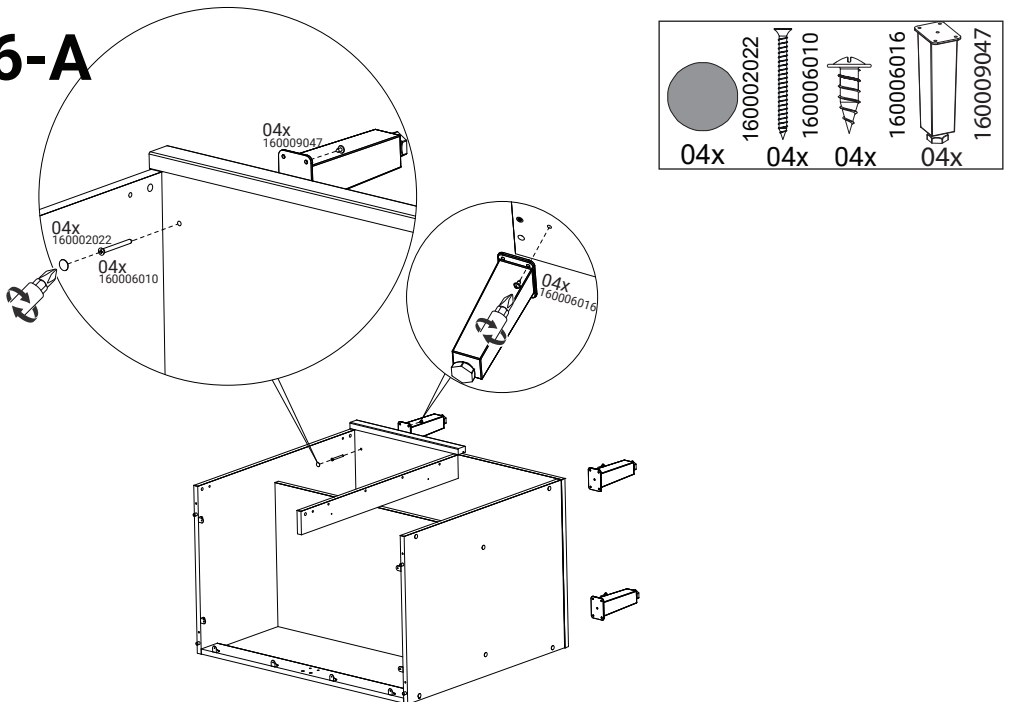

07-A

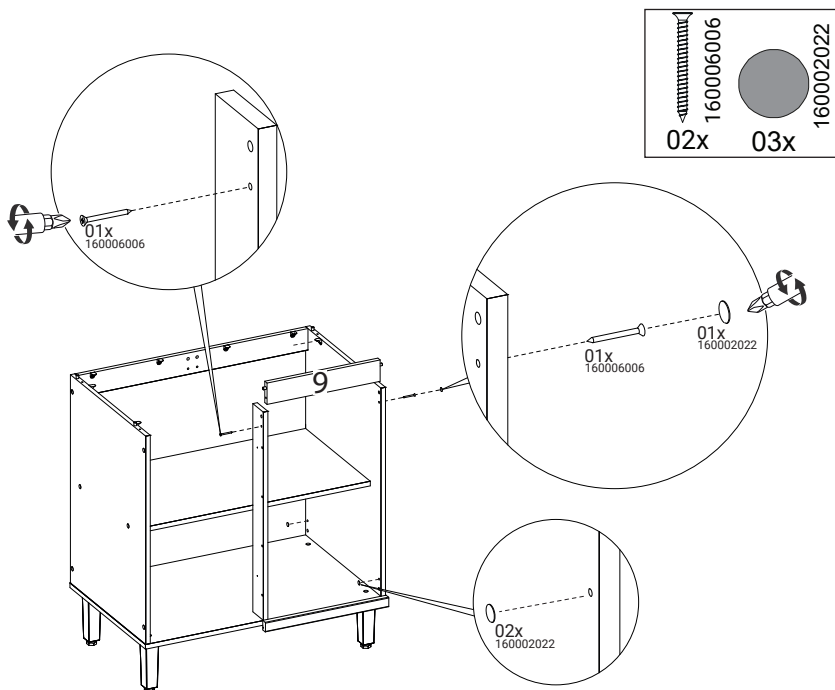

08-A

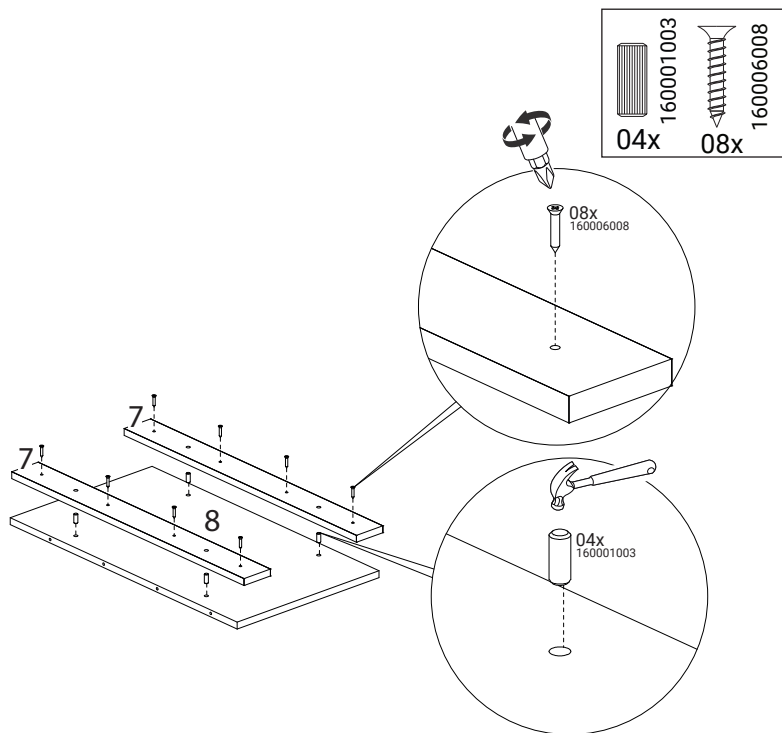

09-A

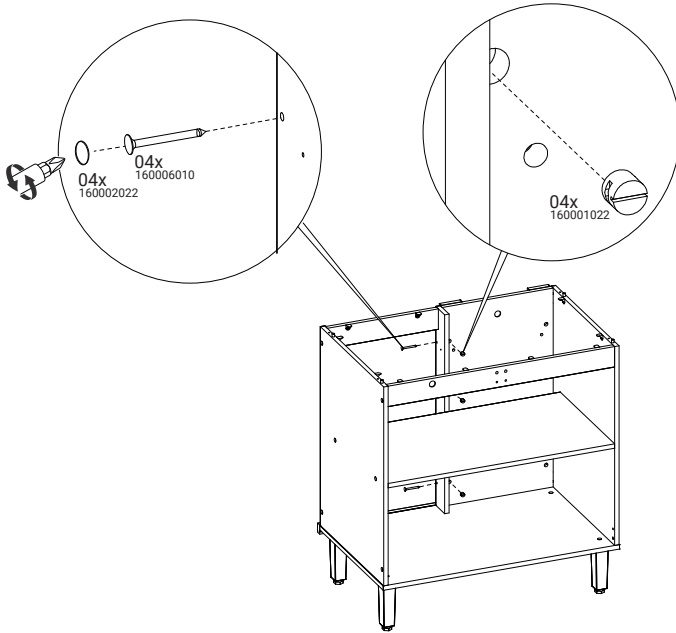
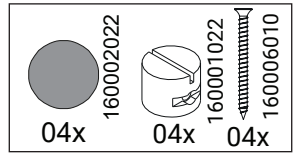

10-A

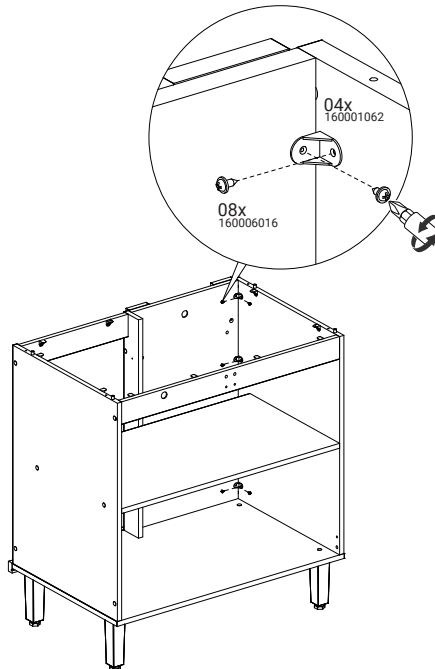
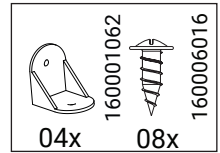

11-A

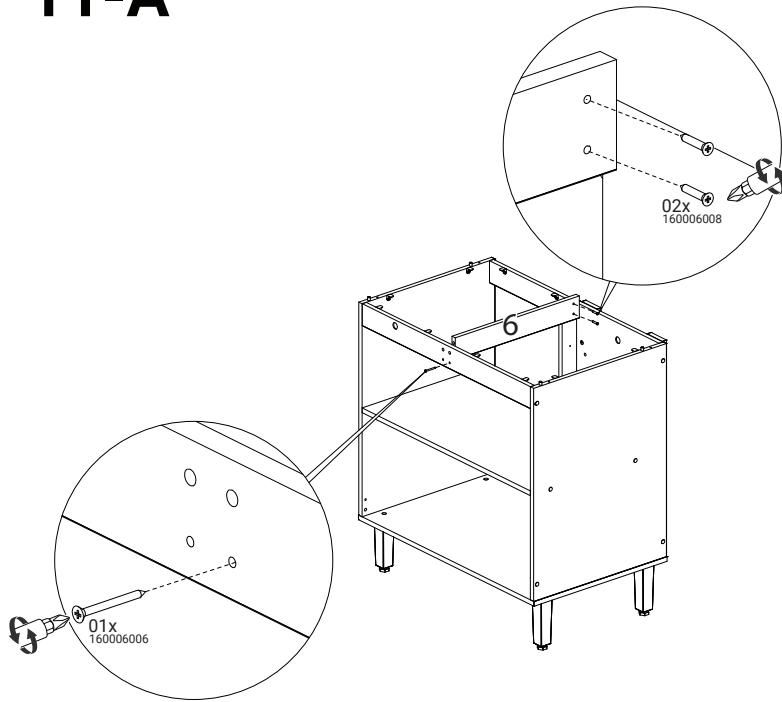
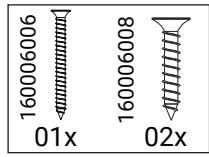

12-A

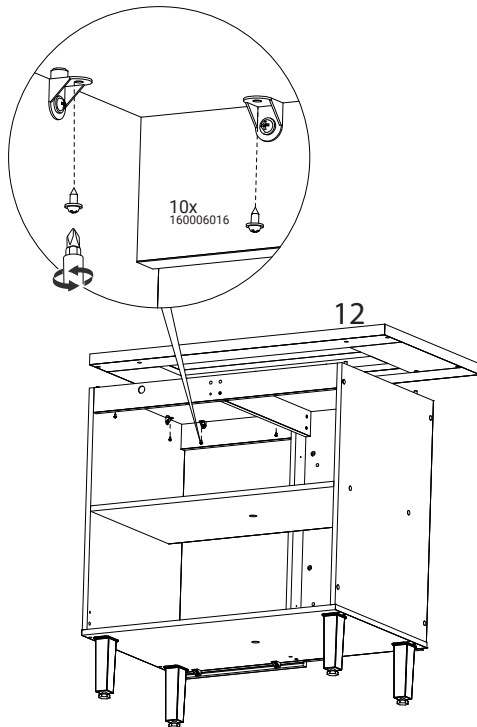
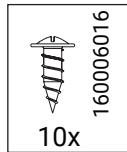

13-A

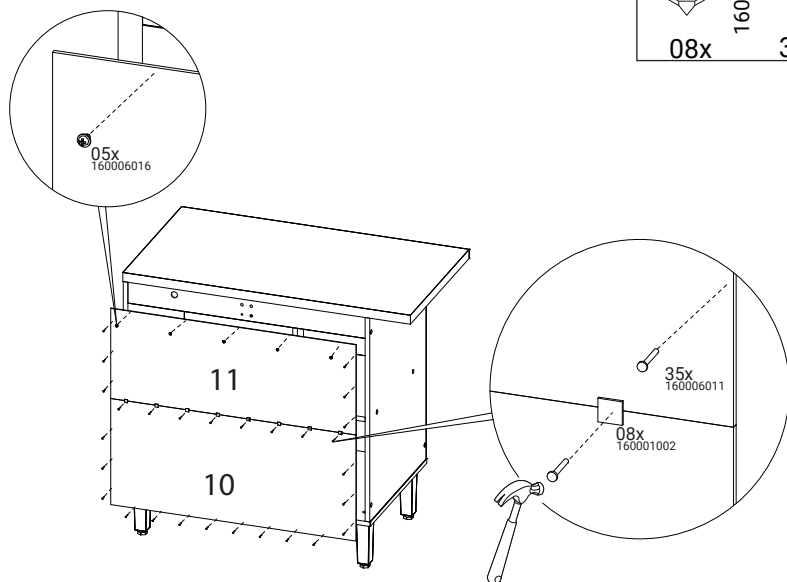
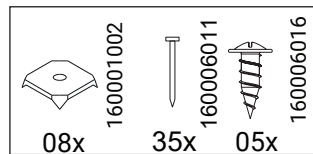

14-A

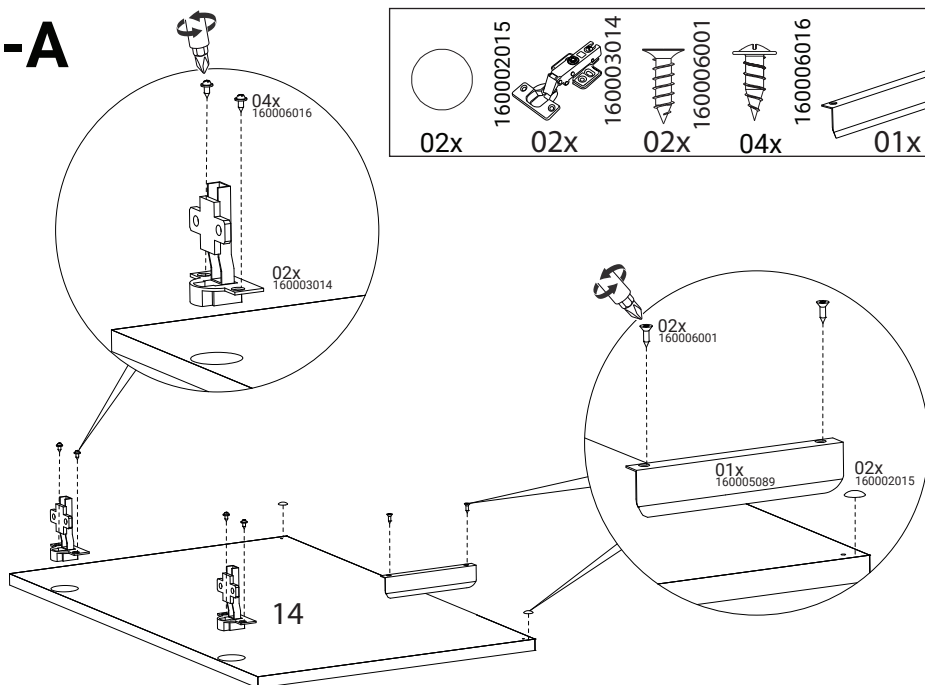
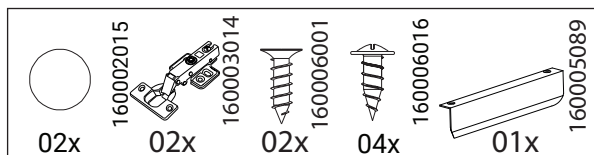

15-A

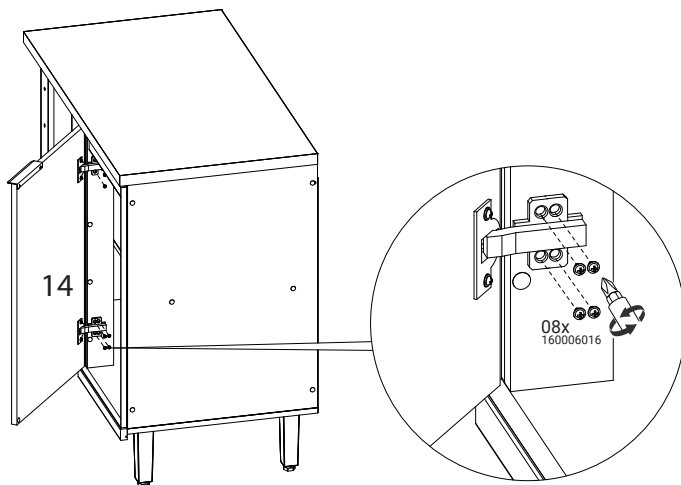
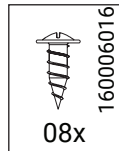

16-A

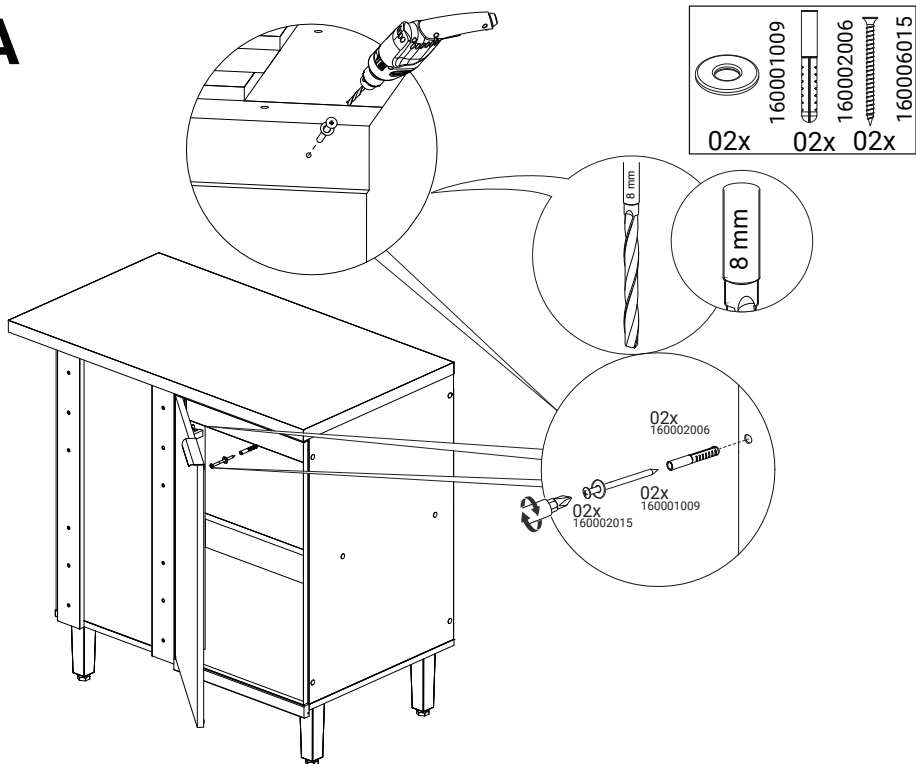

05-B

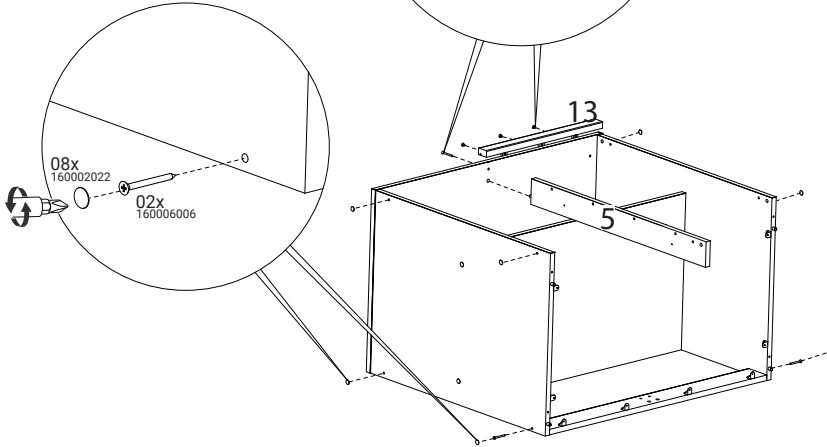
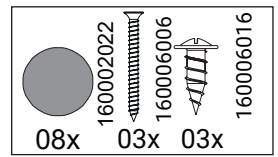

06-B

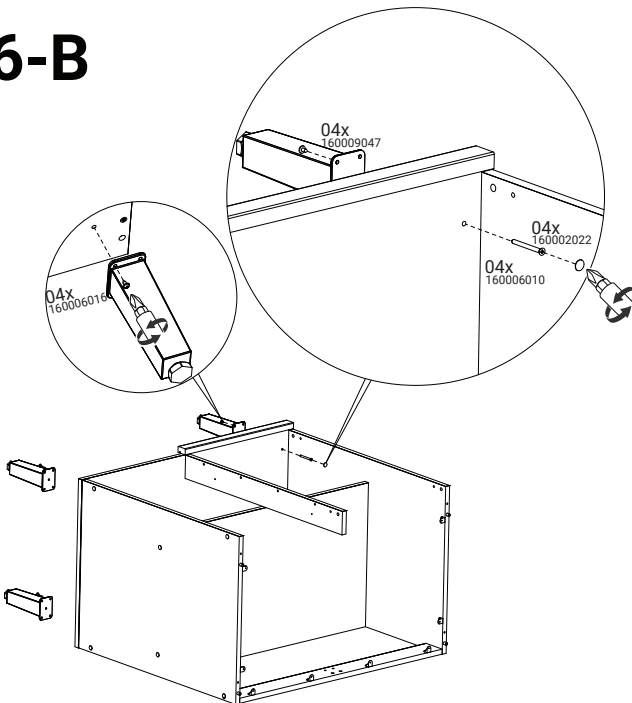
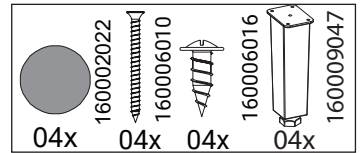

07-B

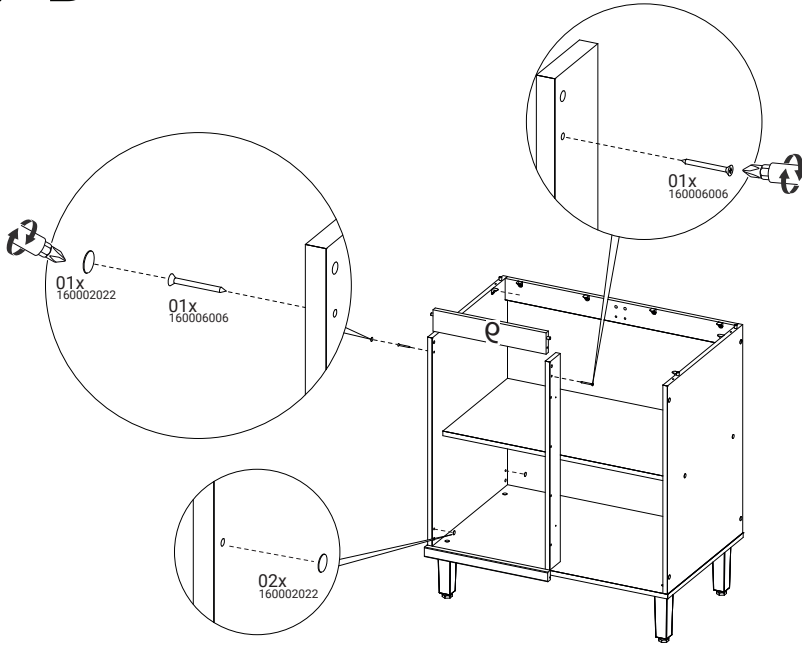
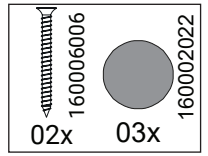

08-B

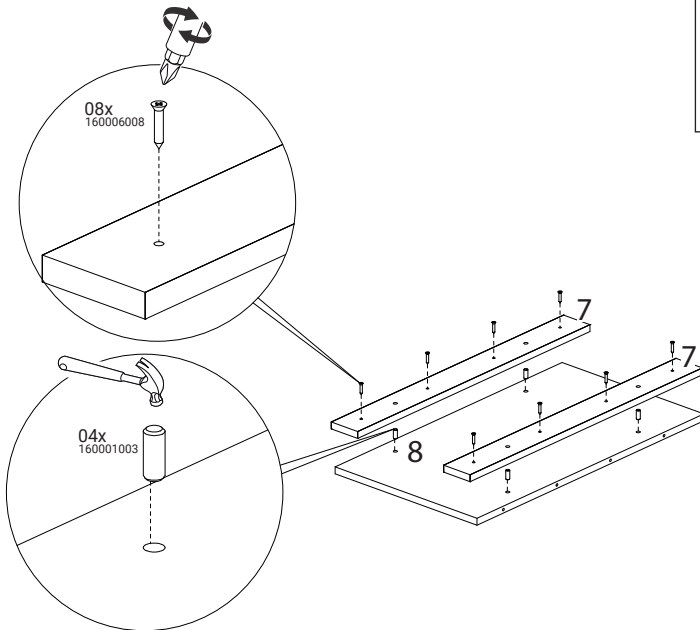
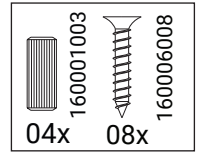

09-B

- 04x 160002022
- 04x 160001022
- 04x 160006010

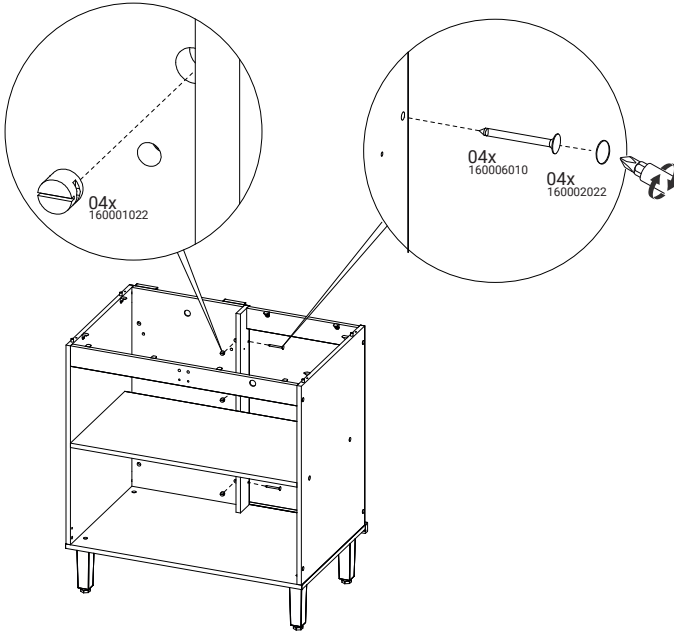

10-B

- 04x 160001062
- 08x 160006016

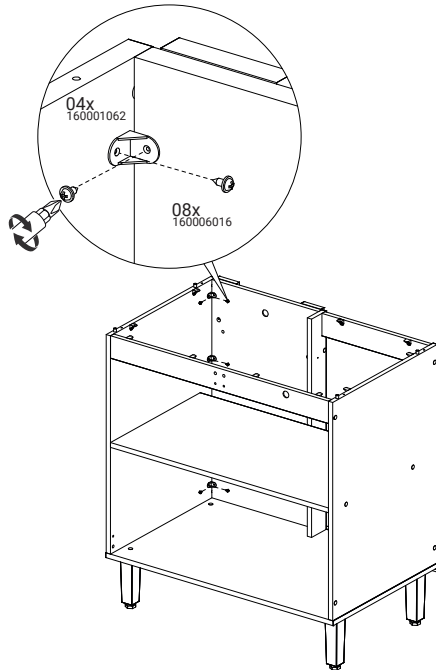

11-B

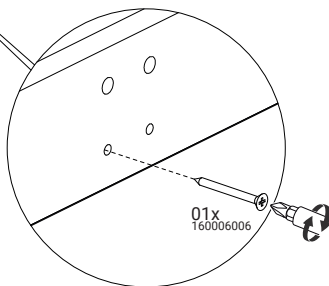
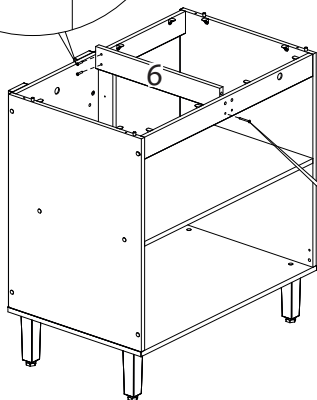
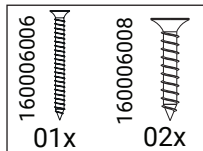
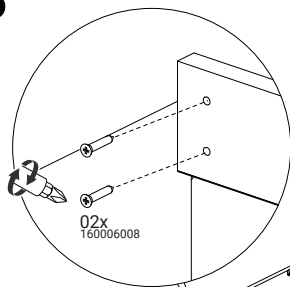

12-B

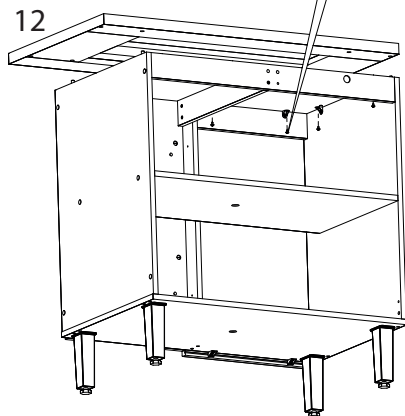
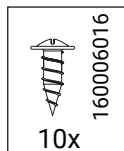
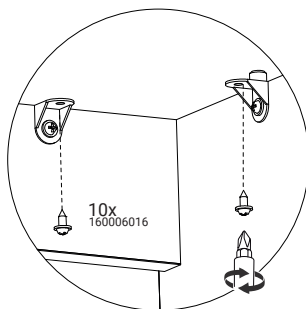

13-B

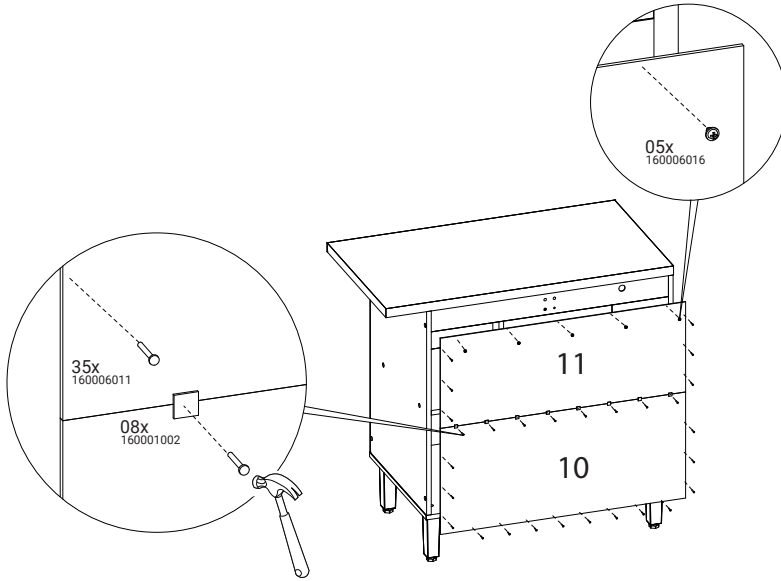
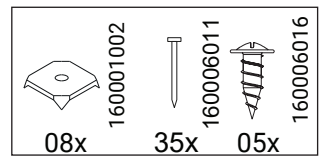

14-B

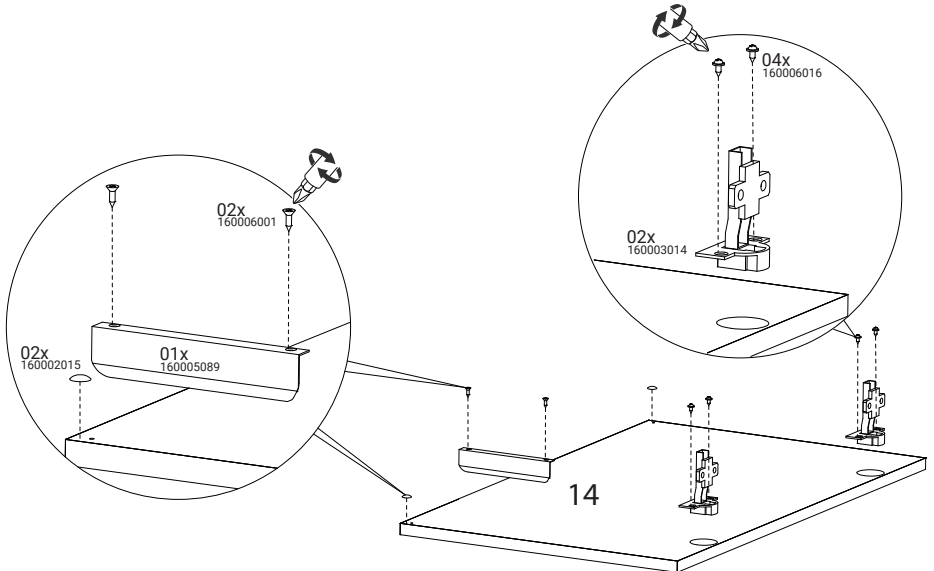
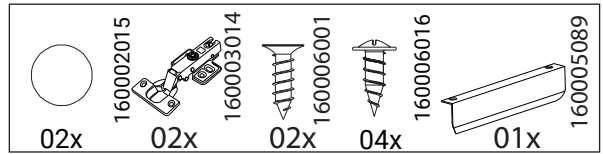

15-B

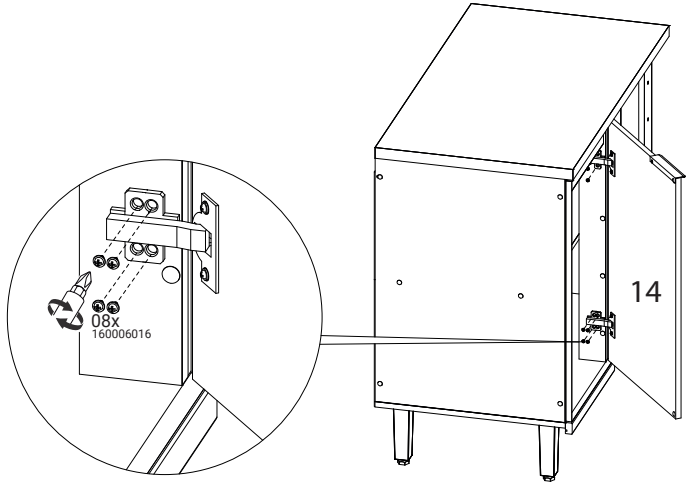
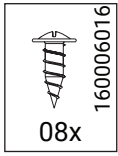

16-B

