

MANUAL DE MONTAGEM / ASSEMBLY INSTRUCTIONS / PLANO DE ARMADO

Antes de montar o móvel, leia com atenção o manual de montagem!
Before assembling the furniture, carefully read the assembly instructions!
Antes de armar el mueble, lea con atención el manual de ensamble!

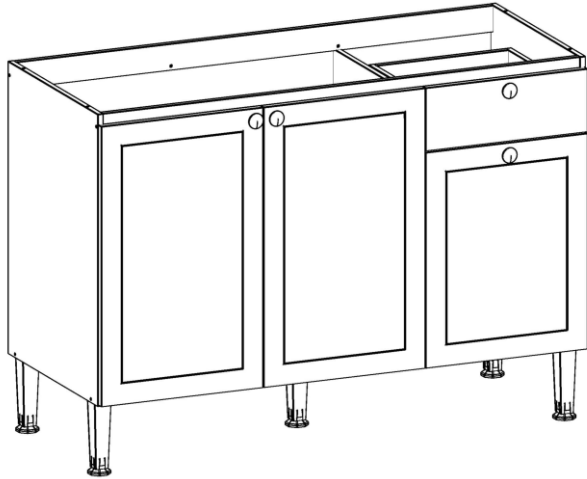

Ref.: 1050

genialflex

Parabéns! Você comprou um produto de excelente qualidade, fabricado com chapa de madeira de MDP ou MDF, extraída de florestas renováveis. Possui alta resistência e design atual.

Congratulations! You have purchased a product of excellent quality, made from MDP or MDF wood veneer, extracted from renewable forests. It has high strength and current design.

Felicitaciones! Usted compró a un producto de excelente calidad, fabricado con placa de madera de MDP o MDF, proveniente de florestas renovables. Tiene alta resistencia y diseño actual.



**ATENÇÃO
ATTENTION
ATENCIÓN**

1) Verifique todas as peças antes de começar a montagem.

Check all parts before starting assembly.

Verifique todas las partes antes de empezar el armado.

2) Ao começar a montagem, não apoie as peças na parede.

When starting the assembly, do not support the parts on the wall.

Al empezar el armado, no apoyes las partes en la pared.

3) Ao colocar as peças e ferragens de lado, cuidado para não perde-las.

When placing parts and hardware aside, be careful not to lose them.

Al poner las piezas y herrajes a parte, cuidado para no dañarlas.

4) O móvel deve ser montado no chão, para isso, use a própria caixa para proteger e não danificar o piso.

The furniture must be mounted on the floor, to do this, use the box itself to protect and not damage the floor.

El mueble suele ser armado al piso, para eso, use la propia caja para protegerlo y no dañar al piso.

5) Comece a montagem seguindo as instruções passo a passo.

Begin assembly by following the step-by-step instructions.

Comience el armado siguiendo la instrucciones paso a paso.

6) É de responsabilidade do montador seguir as intruções desse manual, que são fundamentais para a estrutura do móvel.

It's the assembler's responsibility to follow the instructions in this manual, which are fundamental to the structure of the furniture.

Es de responsabilidad del armador seguir las instrucciones de este manual, que son fundamentales para la estructura del mueble.

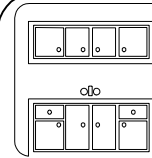

**CUIDADOS
CARE
CUIDADO**

1) A conservação e limpeza deve ser feita com um pano levemente umedecido com água.

Care and cleaning should be done with a cloth slightly moistened with water.

La conservación y limpieza debe ser hecha con un trapo levemente humedecido en agua.

2) Não use produtos abrasivos, como saponáceo, detergentes e esponja de aço.

Do not use abrasive products, such as soap, detergents and steel sponge.

No use productos abrasivos, como saponáceo, detergentes y esponja de acero.

3) Não use cera ou óleo para dar brilho ao móvel.

Do not use wax or oil to shine the furniture.

No use cera o aceites para darle brillo al mueble.

4) Não expor o móvel a interperies e nem ao calor excessivo.

Do not expose the furniture to weather or excessive heat.

No exponer el mueble a interperies ni al calor excesivo.

5) Ao terminar a montagem, limpe o ambiente e o móvel.

When the assembly is finished, clean the room and the furniture.

Al terminar el armado, limpie al ambiente y al mueble.

FERRAMENTAS / TOOLS / HERRAMIENTAS



MARTELO
HAMMER
MARTILLO



MARTELO DE BORRACHA
RUBBER HAMMER
MARTILLO GOMA



CHAVE PHILLIPS
PHILLIPS SCREWDRIVER
LLAVE PHILLIPS



TRENA
MEASURING TAPE
CINTA MÉTRICA



PARAFUSADEIRA
DRILL/ELECTRIC
SCREWDRIVER
DESTORNILLADOR
ELÉCTRICO

PEÇAS / PARTS / PIEZAS

Nº No Num	DESCRIÇÃO DESCRIPTION DESCRIPCIÓN	QTD QTY CANT
1	LATERAL DIREITA RIGHT SIDE LATERAL DERECHA	1
2	LATERAL ESQUERDA LEFT SIDE LATERAL IZQUIERDA	1
3	BASE LOWER TOP TAPA INFERIOR	1
4	DIVISÓRIA DIVISION DIVISORIA	1
5	PILAstra MAIOR BIGGER PILASTER PILAstra MAJOR	1
7	PRATELEIRA SHELF ESTANTE	1
8	TRAVESSA FRONTAL FRONT CROSS TRAVESAÑO FRONTAL	1
9	TRAVESSA TRASEIRA BACK CROSS TRAVESAÑO TRASERO	1
10	PORTA DIREITA RIGHT DOOR PUERTA DERECHA	1
11	PORTA ESQUERDA LEFT DOOR PUERTA IZQUIERDA	2
12	FRENTE DE GAVETA DRAWER FRONT FRENTE DEL CAJÓN	1
13	LATERAL DE GAVETA DRAWER SIDE LATERAL DEL CAJÓN	2
14	COSTA DE GAVETA DRAWER BACK TRASERO DEL CAJÓN	1
15	FUNDO DE GAVETA DRAWER BOTTOM FONDO DEL CAJÓN	1
16	COSTA BACK PANEL DORSO TRASERO	2

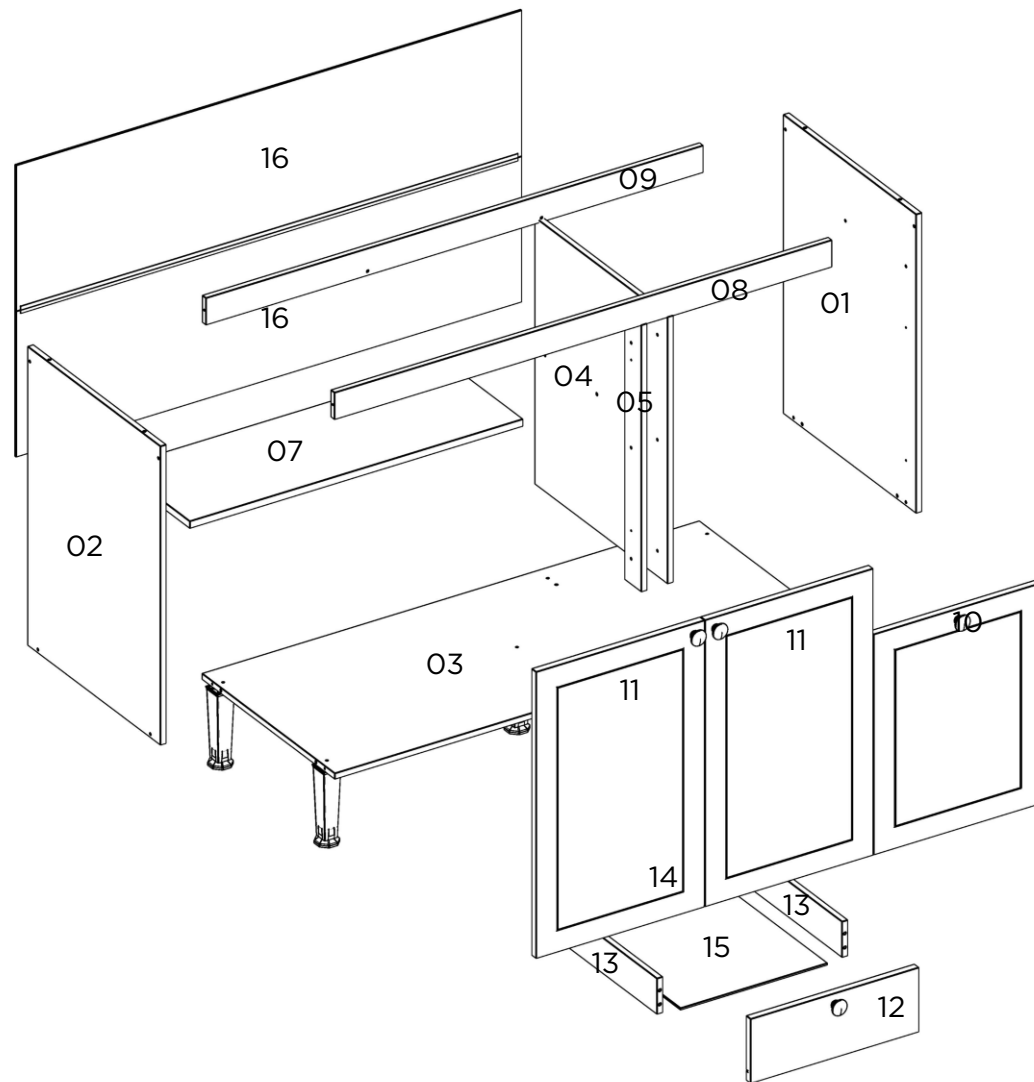

FERRAGENS / HARDWARE / HERRAJES

CÓD CODE COD	DESCRIÇÃO DESCRIPTION DESCRIPCIÓN	QTD QTY CANT
A	CAVILHA 6X30 WOODEN DOWEL 6X30 TARUGO 6X30	10
B	PARAFUSO 4X12mm SCREW 4X12mm TORNILLO 4X12mm	60
D	PARAFUSO 5X50mm SCREW 5X50mm TORNILLO 5X50mm	5
E	PE LEG PATA	5
F	PARAFUSO 3,5X40mm SCREW 3,5X40mm TORNILLO 3,5X40mm	10
G	PARAFUSO 4X20mm SCREW 4X20mm TORNILLO 4X20mm	7
H	PREGO NAIL CLAVO	50
I	PARAFUSO 3,5X25mm SCREW 3,5X25mm TORNILLO 3,5X25mm	4
L	PREGO ANELADO RINGED NAIL CLAVO ANILLADO	4
M	CORREDIÇA GAVETA DRAWER SLIDE CORREDERA DEL CAJÓN	1
N	SUPORTE PRATELEIRA SUPPORT SHELF SOPORTE DE REPISA	4
O	PERFIL H PROFILE H PERFIL H	1
Q	CALÇO PARA DOBRADIÇA HINGE SHED CALZO DE BISAGRA	6
R	DOBRADIÇA HINGE BIZAGRA	6
T	CANTONEIRA DE 2 FUROS ZAMACK METALLIC ANGLE CANTONERA 2 AGUJEROS	2
U	CANTONEIRA DE 4 FUROS METALLIC ANGLE CANTONERA 4 AGUJEROS	6
V	PUXADOR HANDLE TIRADOR	4

UTILIZE A RÉGUA PARA IDENTIFICAR OS PARAFUSOS
USE THE RULER TO IDENTIFY THE SCREWS
UTILICE LA REGLA PARA IDENTIFICAR LOS TORNILLOS

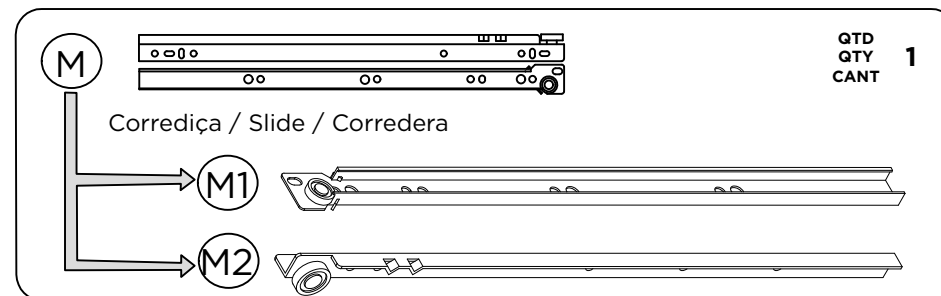

PESO SUPORTADO / WEIGHT SUPPORTED / PESO SOPORTADO

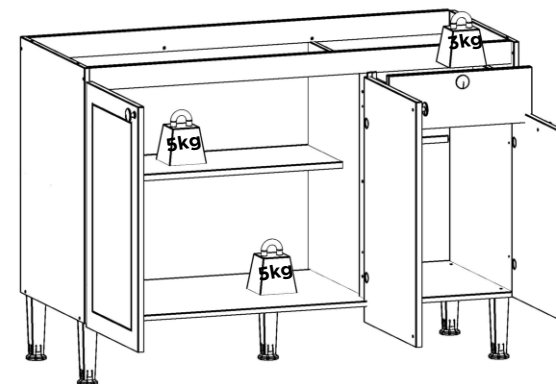

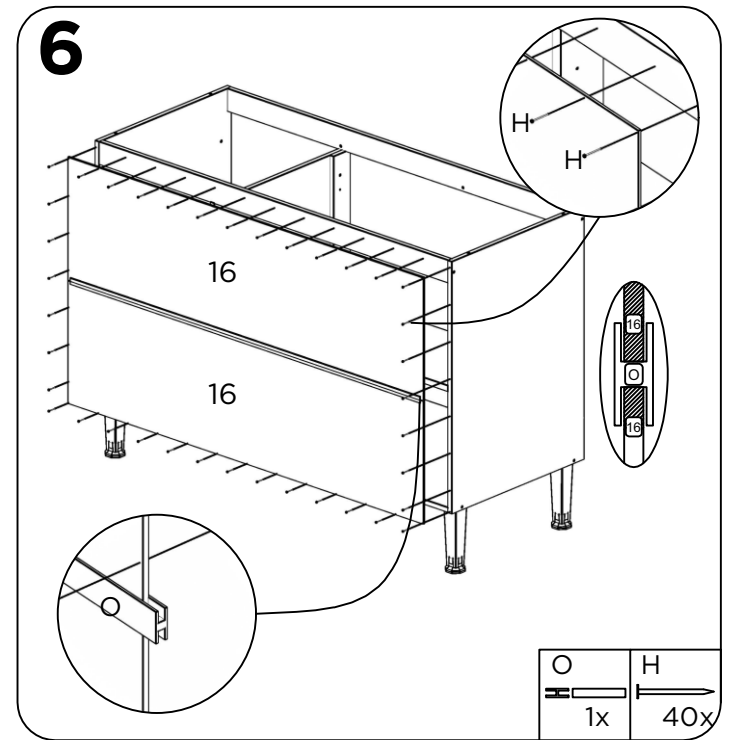
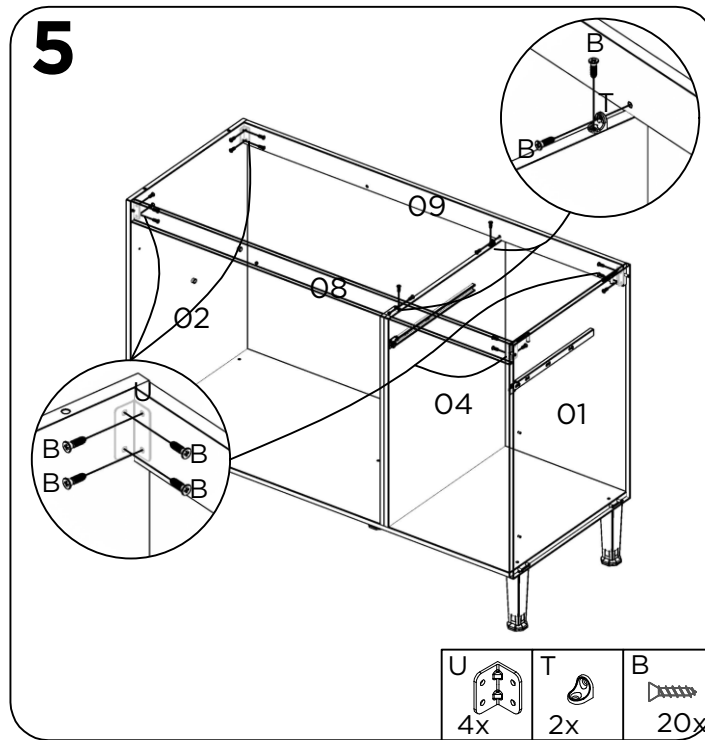
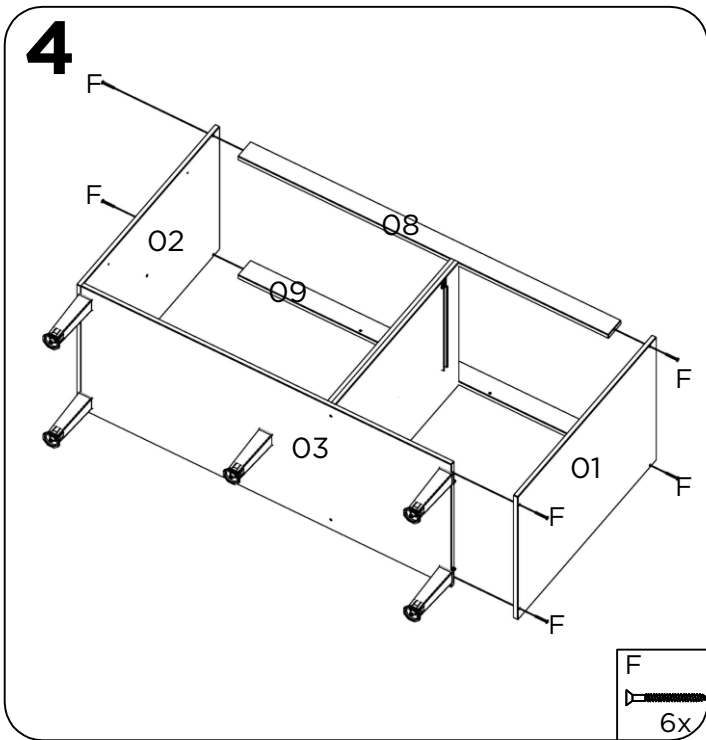
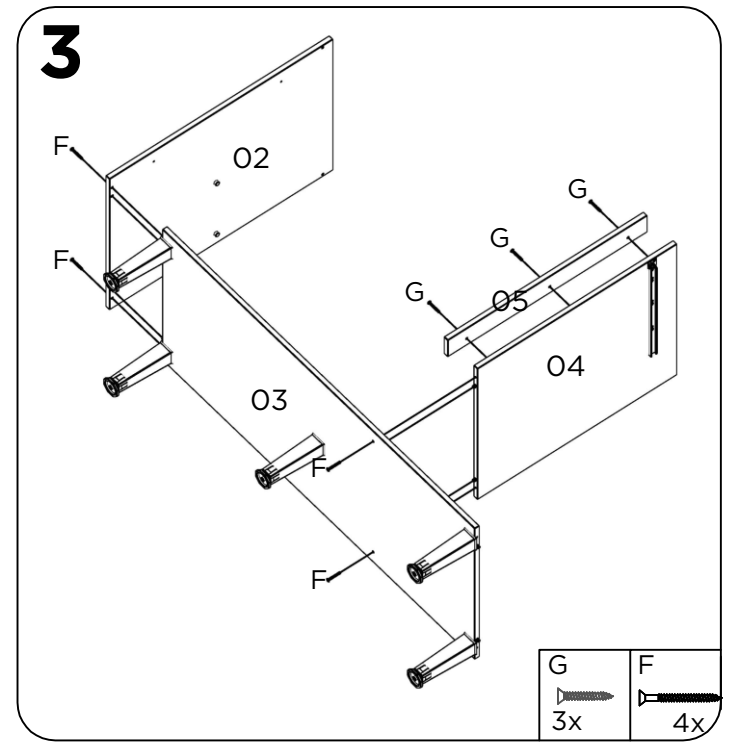
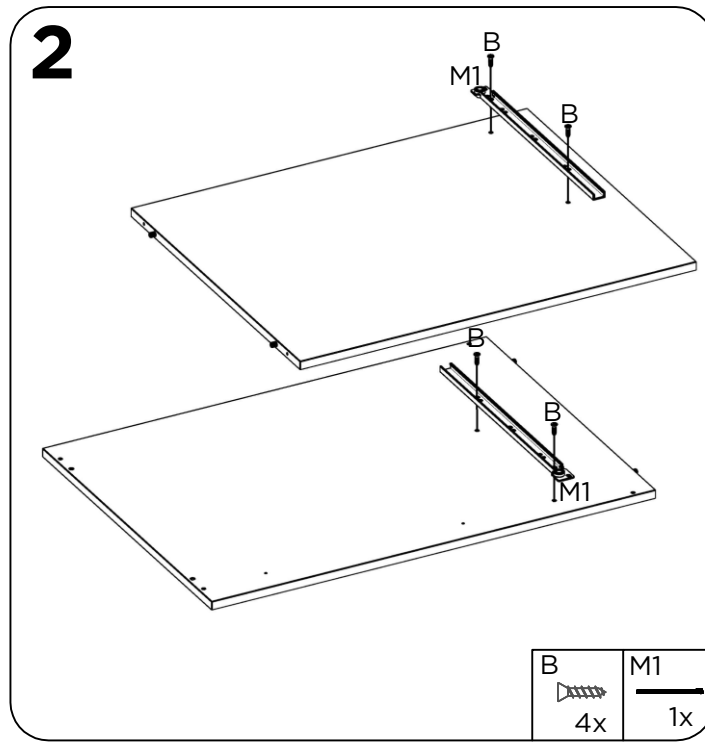
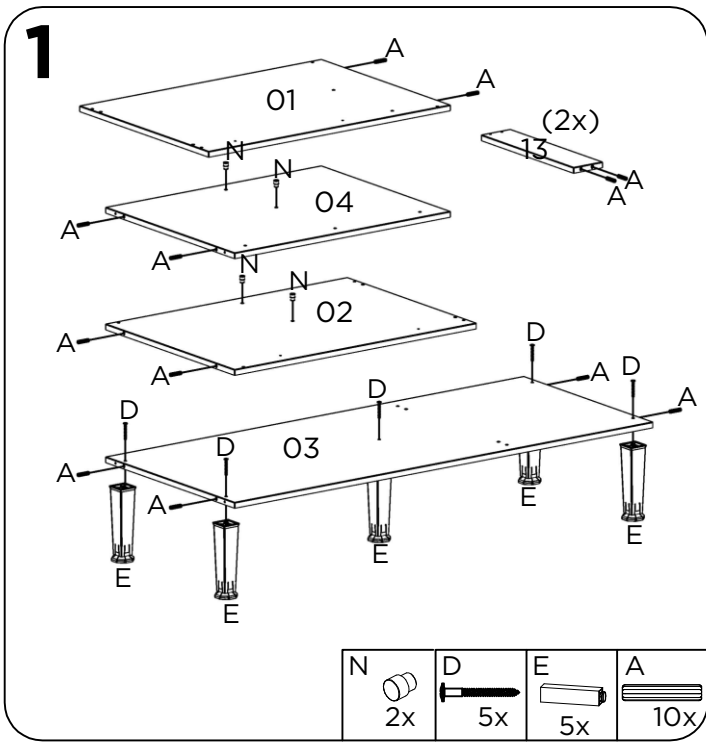

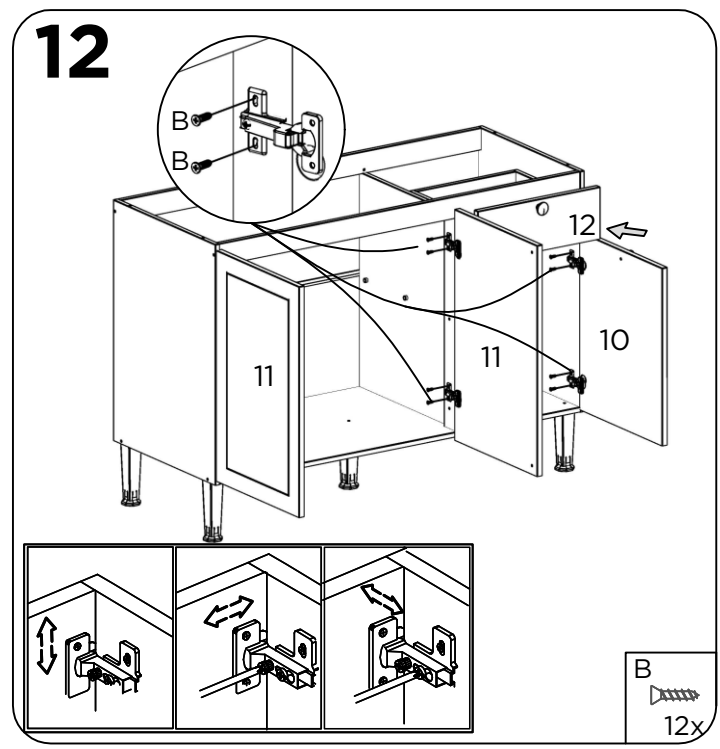
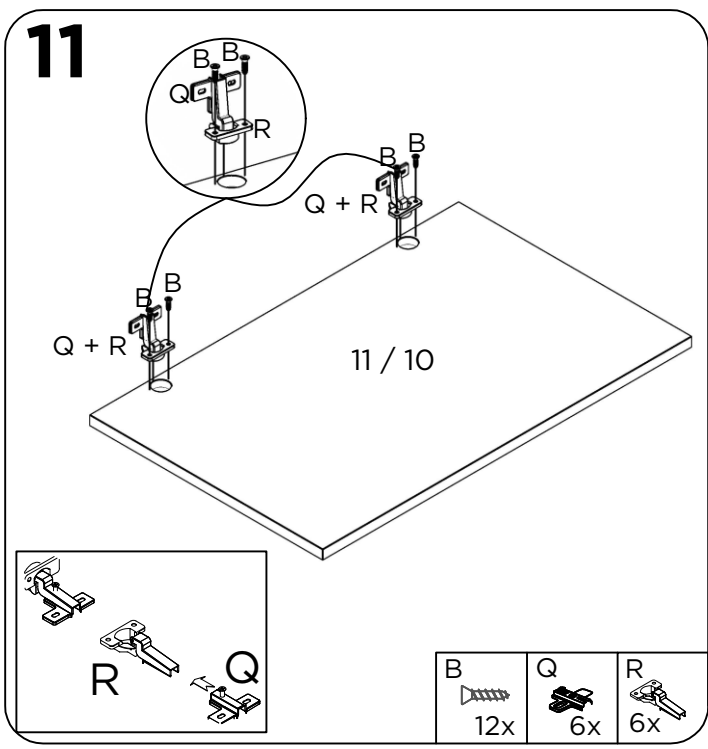
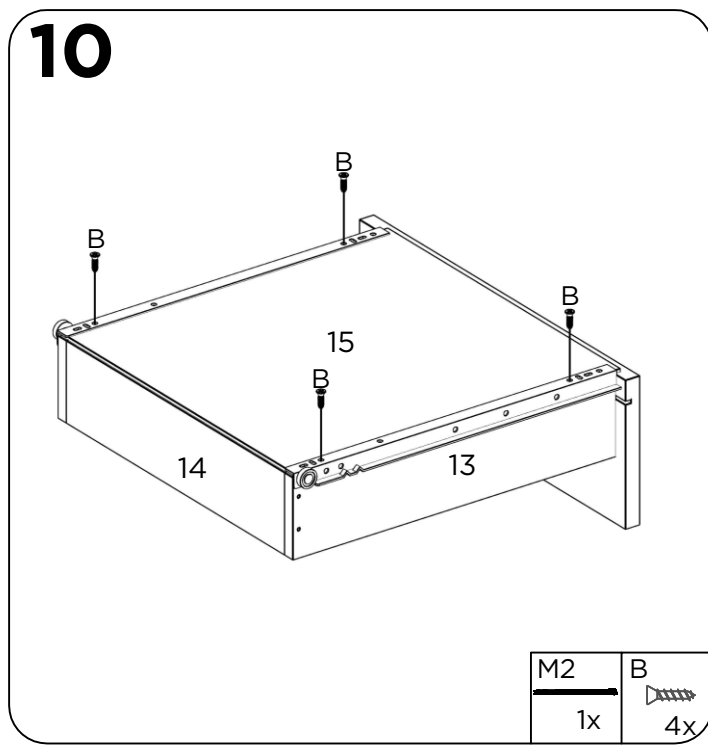
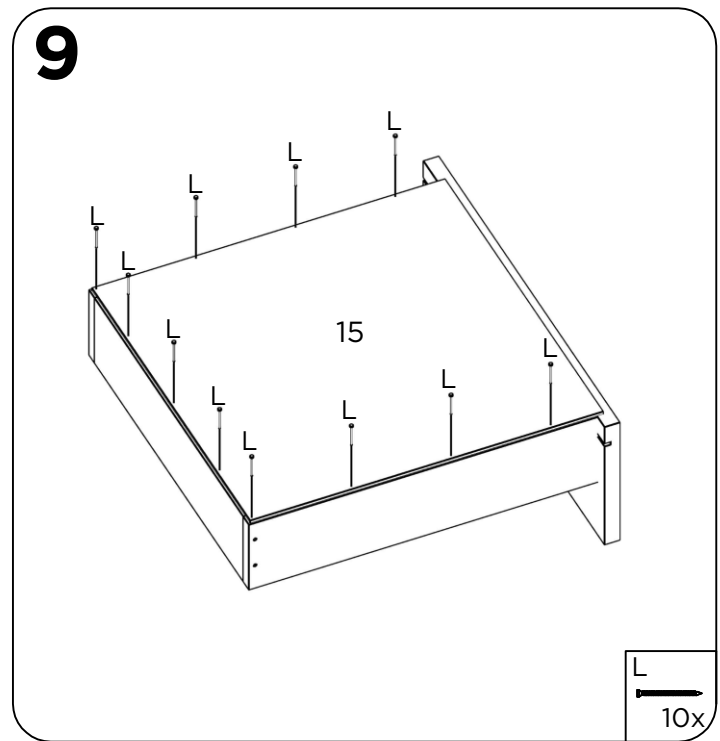
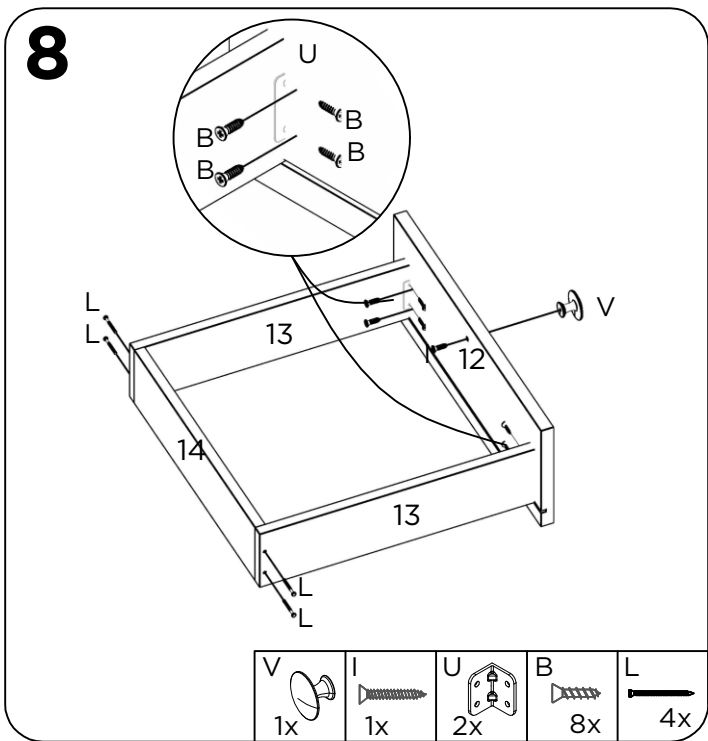
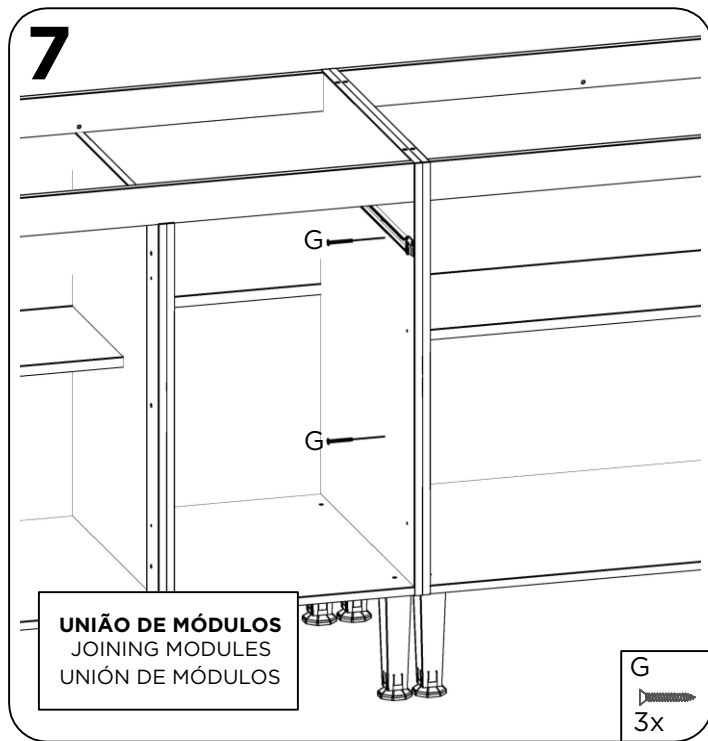

13

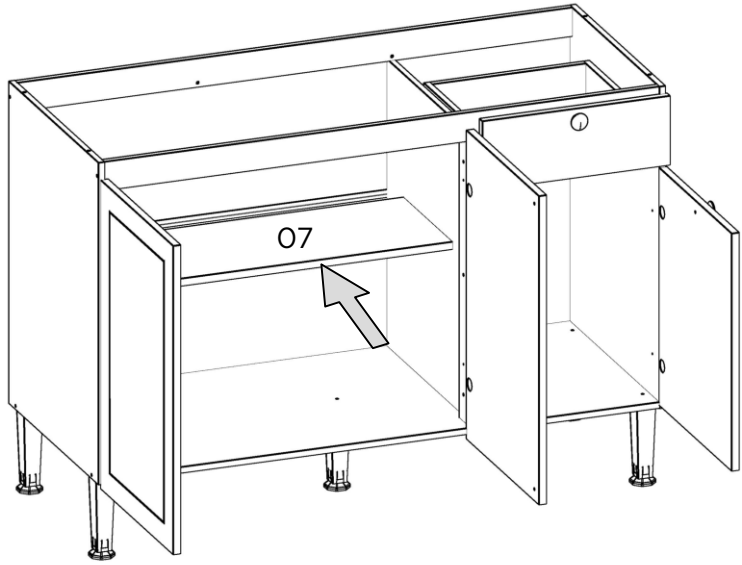

14

