

ASPECTO TRASEIRO / BOTTOM ASPECT /
ASPECTO TRASERO

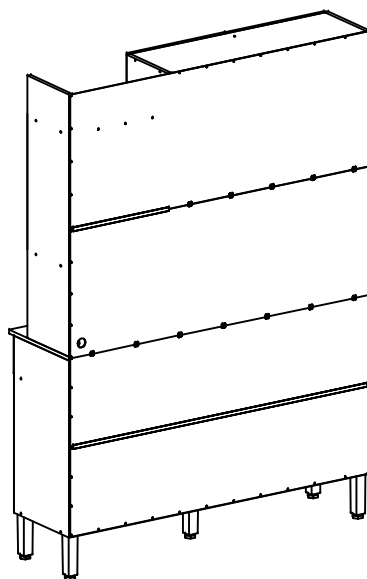

Nº	CÓDIGO	NOME DA PEÇA / NAME OF THE PIECE / NOMBRE DE LA PIEZA	MEDIDA	QTDE	MAT. PRIMA
VOLUME 1					
01	910385	PERFIL I 1290MM / PLASTIC PROFILE I 1290MM / PERFIL I 1290MM	1290MM	01	PLÁSTICO
02	110463.1290.0355	BASE II / BASE II / BASE II	1290x355x15	01	MDP
03	110464.1290.0070	SUORTE FRONTAL / FRONT SUPPORT / APOYO FRONTAL	1290x70x15	01	MDP
04	110471.1320.0385	TAMPO / COVER / TAPA	1320x385x15	01	MDP
05	110472.0145.0648	FRENTE DE GAVETA / DRAWER FRONT / FRENTE DEL CAJÓN	145x648x15	02	MDP
06	110473.0520.0430	PORTA INF ESQ-SUP DIR / LOWER LEFT - UPPER RIGHT DOOR / PUERTA INF IZQ - SUP DER	520x430x15	02	MDP
06-A	110473.0520.0430	PORTA SUP. DIR. COMPOSÉ / COMPOSE UPPER RIGHT DOOR / PUERTA SUP. DER. COMPOSE	520x430x15	01	MDP
07	110474.0520.0430	PORTA INF DIR-SUP ESQ / LOWER RIGHT-UPPER LEFT DOOR / PUERTA INF. DER - SUP IZQ	520x430x15	03	MDP
08	110477.1315.0515	TRASEIRO SUPERIOR / UPPER BOTTOM / TRASERO SUPERIOR	1315x515x03	01	MADEFIBRA
09	110478.1315.0490	TRASEIRO INTERM. / INTERMEDIARY BOTTOM / TRASERO INTERMEDIARIO	1315x490x03	01	MADEFIBRA
10	110479.1315.0340	TRASEIRO INFERIOR / LOWER BOTTOM / TRASERO INFERIOR	1315x340x03	02	MADEFIBRA
VOLUME 2					
11	110458.0675.0355	LATERAL INF. DIREITA / LOWER RIGHT LATERAL / LATERAL INF. DERECHA	675x355x15	01	MDP
12	110459.0675.0355	LATERAL INF. ESQUERDA / LOWER LEFT LATERAL / LATERAL INF. IZQUIERDA	675x355x15	01	MDP
13	110460.0145.0355	DIVISÃO INFERIOR / LOWER DIVISION / DIVISIÓN INFERIOR	145x355x15	01	MDP
14	110461.1000.0268	LATERAL SUP. DIREITA / UPPER RIGHT LATERAL / LATERAL SUP. DERECHA	1000x268x15	01	MDP
15	110462.1000.0268	LATERAL SUP. ESQUERDA / UPPER LEFT LATERAL / LATERAL SUP. IZQUIERDA	1000x268x15	01	MDP
16	100770.0500.0070	BATENTE ESQUERDO / LEFT DOORPOST / DIVISIÓN IZQUIERDA	500x70x15	01	MDP
17	100771.0500.0070	BATENTE DIREITO / RIGHT DOORPOST / DIVISIÓN DERECHA	500x70x15	01	MDP
18	110465.0420.0268	CHAPÉU-BASE I DIREITA / RIGHT HAT - BASE I / CUBIERTA-BASE I DERECHA	420x268x15	02	MDP
19	110466.0855.0268	CHAPÉU ESQUERDO / LEFT HAT / CUBIERTA IZQUIERDA	855x268x15	01	MDP
20	110467.0675.0268	DIVISÃO SUPERIOR / UPPER DIVISION / DIVISIÓN SUPERIOR	675x268x15	01	MDP
21	110468.0855.0197	PRATELEIRA I ESQUERDA / LEFT SHELF I / REPISA I IZQUIERDA	855x197x15	01	MDP
22	110469.0495.0070	BATENTE SUPERIOR / UPPER DOORPOST / DIVISIÓN SUPERIOR	495x70x15	01	MDP
23	110470.0855.0268	BASE I ESQUERDA / LEF BASE I / BASE I IZQUIERDA	855x268x15	01	MDP
24	107369.0350.0100	LATERAL DE GAVETA / DRAWER SIDEBORD / LATERAL DEL CAJÓN	350x100x15	04	MDP
25	110475.0582.0080	CONTRA FUNDO DE GAVETA / DRAWER BOTTOM BOARD / CONTRA FONDO DEL CAJÓN	582x80x15	02	MDP
26	110476.0610.0355	FUNDO DE GAVETA / DRAWER BOTTOM BOARD / CONTRA FONDO DEL CAJÓN	610x355x03	02	MADEFIBRA
VOLUME 03					
27	110457	ACESSÓRIO DE MONTAGEM / ACCESSORY ASSEMBLY / ACCESORIO DE MONTAJE	-	01	DIVERSOS
28	907279	CORREDIÇA (PAR) / SLIDING (EQUAL) / CORREDERA (PAR)	350MM	02	METAL
29	908640	PÉS / FEET / PATA	170MM	05	PLÁSTICO
30	910384	PERFIL I 420MM / PLASTIC PROFILE I 420MM / PERFIL I 420MM	420MM	01	PLÁSTICO

↓
CÓDIGOS IDENTIFICADOS NO TOPO DA MAIORIA DAS PEÇAS DO PRODUTO.
THESE CODES ARE IDENTIFIED ON THE SIDE OF MOST PARTS OF THE PRODUCT.
CÓDIGO IMPRESO EN EL CANTO CRUDO DE LA MAYORIA DE LAS PIEZAS.



- PESSOAS NECESSÁRIAS P/ MONTAGEM.
- REQUIRED PEOPLE FOR ASSEMBLY.
- CANTIDAD DE PERSONAS NECESSARIAS PARA ARMAR.











1 PESSOA
1 PERSON
1 PERSONA

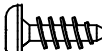

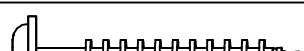

ATENÇÃO / ATTENTION / ATENCIÓN:

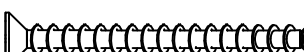
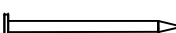
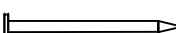
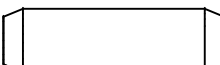
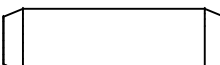
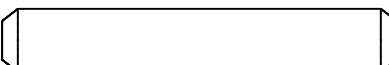
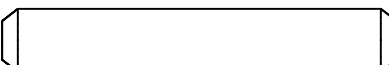
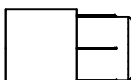
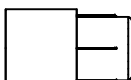
- A LIMPEZA DO MÓVEL DEVE SER EFETUADA SOMENTE COM PANO MACIO E MODERADAMENTE UMEDECIDO COM ÁGUA PURA OU SOLUÇÃO COM SABÃO NEUTRO.
- FOR CLEANING, USE ONLY A SOFT CLOTH MODERATELY MOISTENED WITH PURE WATER OR A SOLUTION WITH NEUTRAL SOAP.
- PARA LIMPIEZA DEL MUEBLE USAR PAÑO SUAVE Y MODERADAMENTE HUMEDECIDO CON AGUA PURA O SOLUCIÓN CON JABÓN NEUTRO.
- NÃO UTILIZE PRODUTOS QUÍMICOS OU ABRASIVOS, TAIS COMO: CERA, ÁLCOOL, DETERGENTES, TINNER.
- DO NOT USE CHEMICAL OR ABRASIVE PRODUCTS. FOR EXAMPLE: WAX, ALCOHOL, DETERGENT, THINNER.
- NO APLICAR PRODUCTOS QUÍMICOS O ABRASIVOS TAIS COMO: CERAS, ALCOOL, THINNER, DETERGENTE.
- AO SOLICITAR ASSISTÊNCIA TÉCNICA, INFORME O CÓDIGO DO PRODUTO, A COR E O CÓDIGO DA PEÇA CORRETAMENTE.
- WHEN REQUESTING TECHNICAL ASSISTENCE, INFORM THE PRODUCT CODE, THE COLOR AND THE PIECE CODE CORRECTLY.
- SI NECESITAR REPUESTOS, INFORMAR EL CÓDIGO DEL PRODUCTO, EL COLOR Y EL CÓDIGO DE LA PIEZA.

LISTA DE ACESSÓRIOS / ACCESSORY LIST / LISTAJE DE ACCESORIO - 1X1

		A 28 911268 - PARAF. 3,5X12 CHATA CABEÇA 6,8
		B 21 907532 - PARAF. 4,0X12 CABEÇA PANELA
		C 16 903540 - PARAF. 3,5X25 C/ PONTA FLANGEADO
		D 05 903557 - PARAF. 5,0X35 FLANGEADO
		E 41 903542 - PARAF. 3,5X40
		F 70 904801 - PREGO 09X09
		G 43 902913 - CAVILHA 8X30
		H 02 902915 - CAVILHA 8X50
		I 04 904980 - SUPORTE DE PRATELEIRA

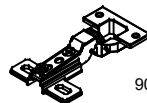
LISTA DE ACESSÓRIOS / ACCESSORY LIST / LISTAJE DE ACCESORIO

	J 12 900456 - FIXADOR P/ FUNDO		M 08 910617 - PUXADOR NOCE
	K 10 902900 - CANTONEIRA METÁLICA		N 06 904982 - KIT DOBRAD. ALTA C/ 2
	L 01 900970 - PASSA FIO ADESIVO		O 01 910350 - CANTONEIRA PLÁSTICA 20X20

**ESTRUTURA
STRUCTURE
ESTRUCTURA**

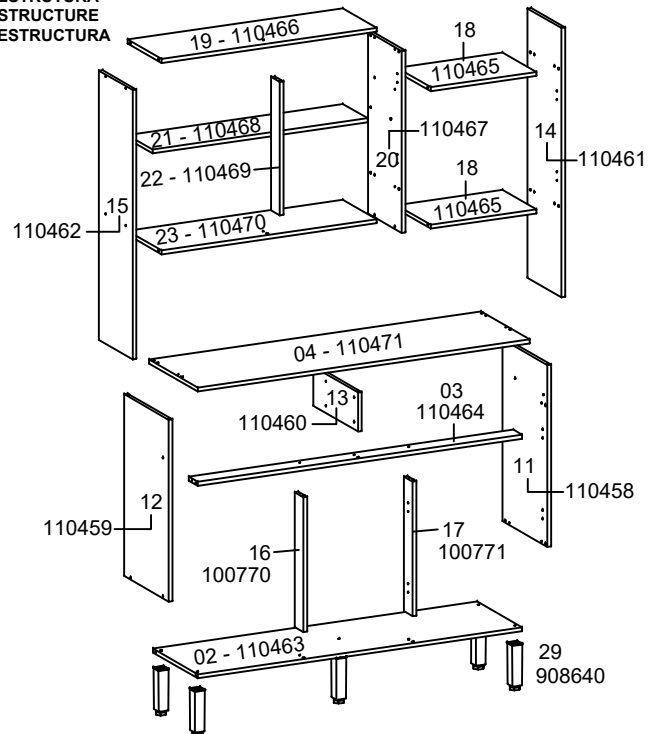

**TRASEIRO
BOTTOM
TRASERO**

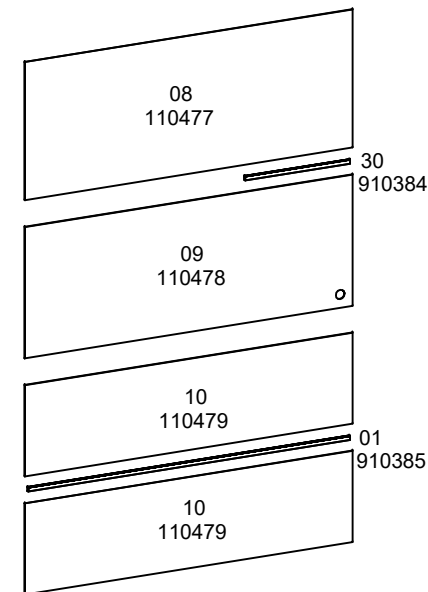

**GAVETA
DRAWER
CAJÓN**

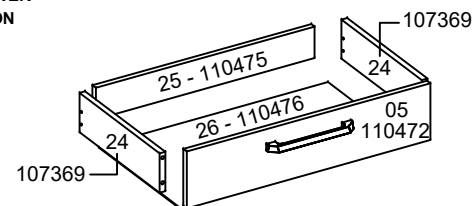

**FRENTE
FRONT
FRENTE**

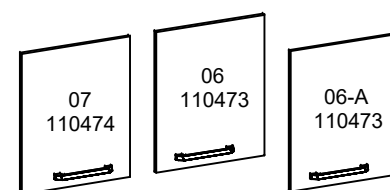

**FERRAMENTAS NECESSÁRIAS P/ MONTAGEM.
(NÃO SÃO FORNECIDAS)
REQUIRED TOOLS FOR ASSEMBLY. (NOT PROVIDED)
HERRAMIENTAS NECESSARIAS. (NO PROPORCIONADAS)**

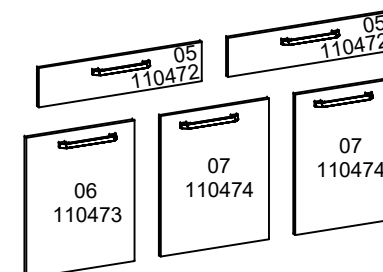
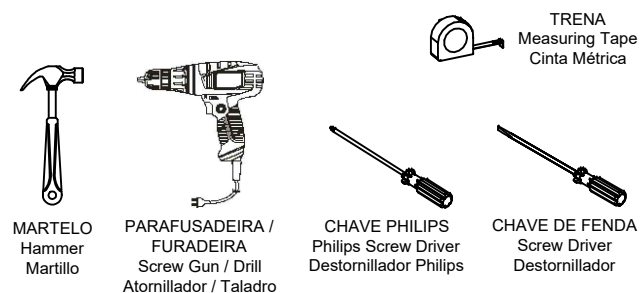

① MONTAGEM DAS GAVETAS.
DRAWERS ASSEMBLY.
MONTAJE DE LOS CAJONES.

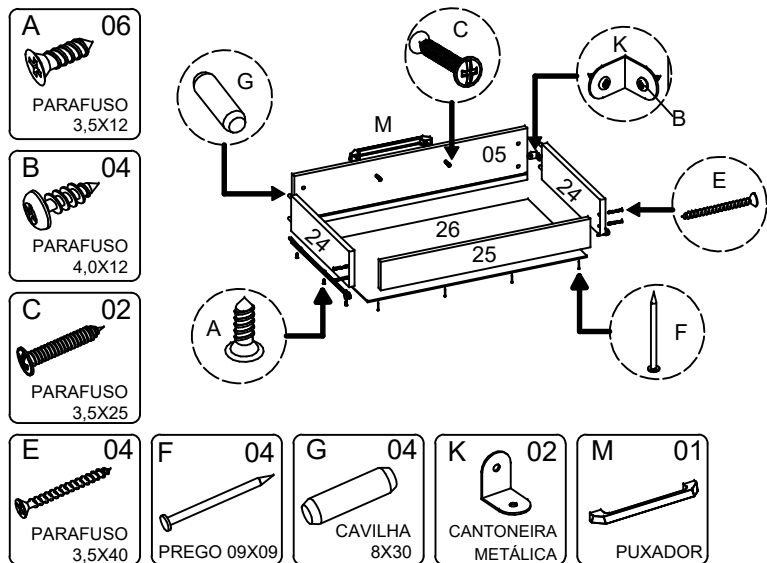

② MONTAGEM DA ESTRUTURA INFERIOR.
LOWER STRUCTURE ASSEMBLY.
MONTAJE DE LA ESTRUCTURA INFERIOR.

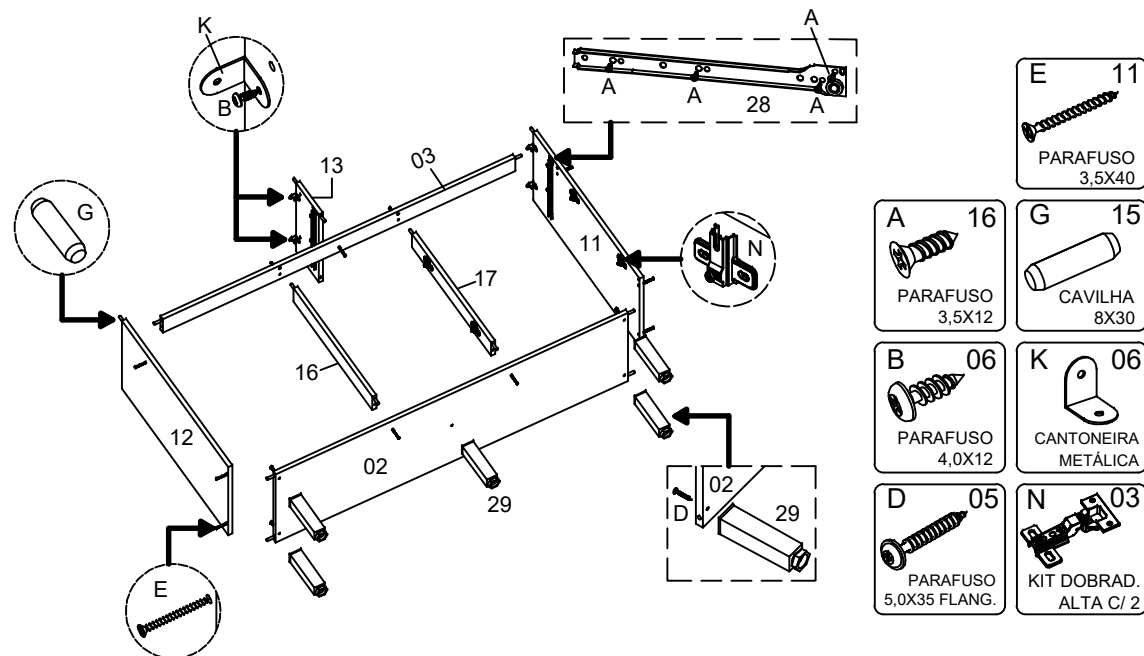

③ MONTAGEM DA ESTRUTURA SUPERIOR.
UPPER ASSEMBLY STRUCTURE.
MONTAJE DE LA ESTRUCTURA SUPERIOR.

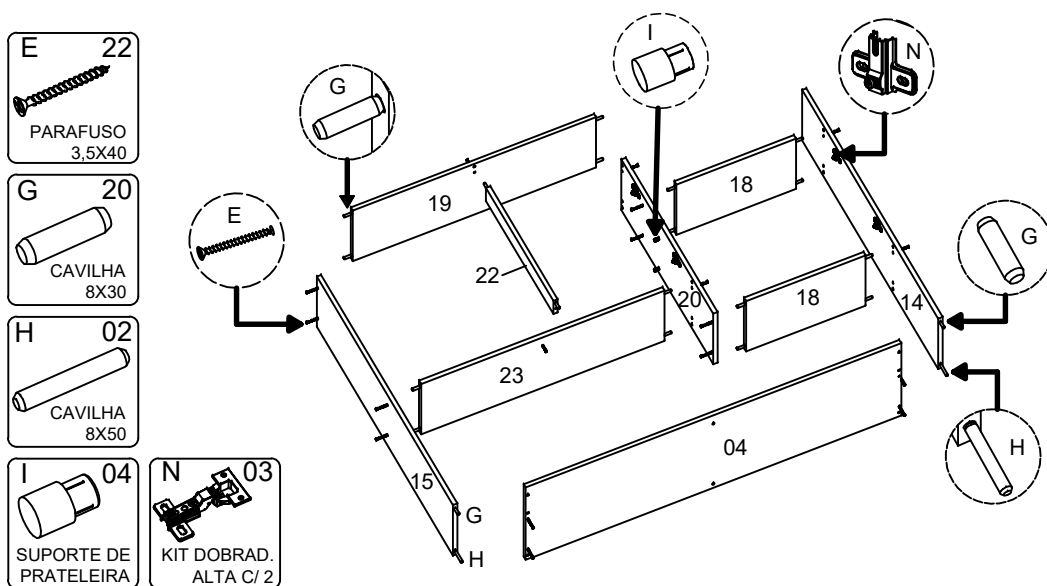

④ FIXAÇÃO DA ESTRUTURA INF. C/ A SUP.
UPPER STRUCTURE ATTACHMENT INTO LOWER.
FIJACIÓN DE LA ESTRUCTURA INF. CON LA SUP.

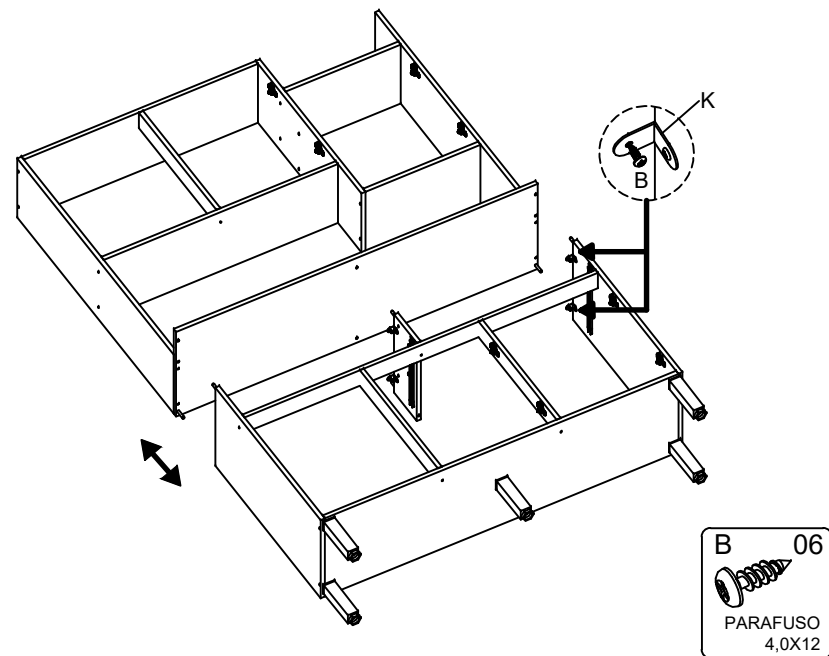

⑤ COLOCAÇÃO DA PRATELEIRA I.
SHELF I PLACEMENT.
COLOCACIÓN DE LA REPISA I.

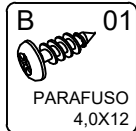
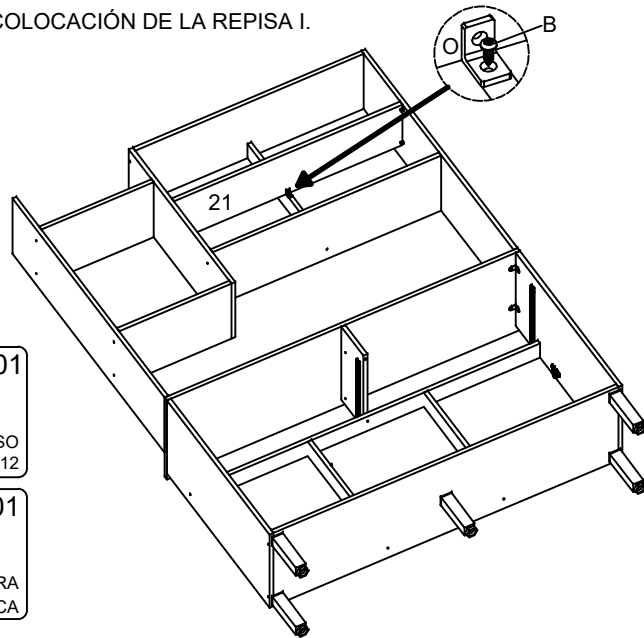

⑥ FIXAÇÃO DOS TRASEIROS.
BOTTOMS ATTACHMENT.
FIJACIÓN DE LOS TRASEROS.

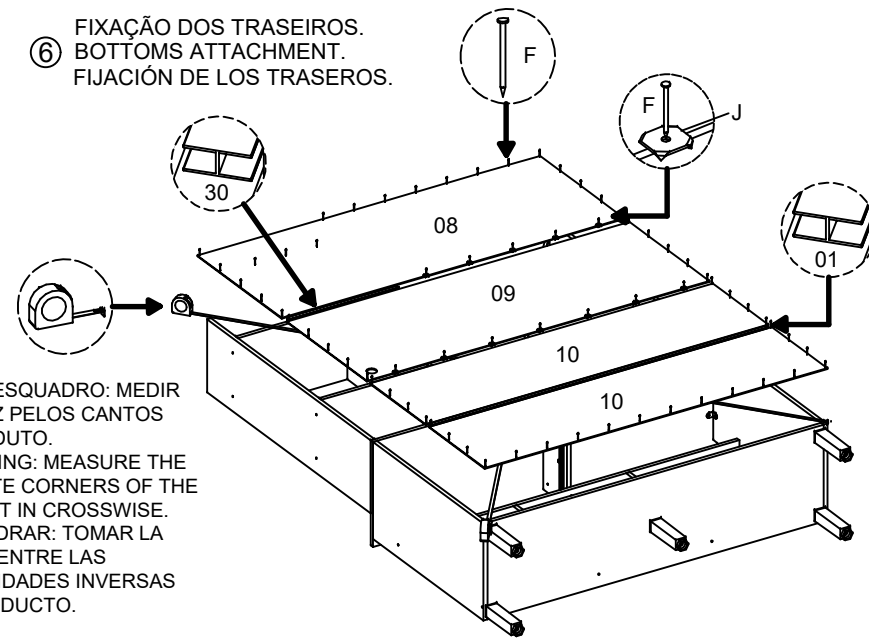

- TIRAR ESQUADRO: MEDIR EM CRUZ PELOS CANTOS DO PRODUTO.
- SQUARING: MEASURE THE OPPOSITE CORNERS OF THE PRODUCT IN CROSSWISE.
- ESCUADRAR: TOMAR LA MEDIDA ENTRE LAS EXTREMIDADES INVERSAS DEL PRODUCTO.



⑦ COLOCAÇÃO DAS PORTAS E GAVETAS.
DOORS AND DRAWERS PLACEMENT.
COLOCACIÓN DE LAS PUERTAS Y CAJONES.

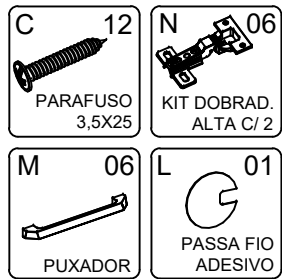

☞ - INFORMAÇÃO AO MONTADOR:
USAR PARAFUSADEIRA NO
TORQUE BAIXO!

- INFORMATION TO THE ASSEMBLER:
USE THE CORDLESS DRILL AT
LOW TORQUE.

- INFORMACIÓN AL ARMADOR:
UTILIZAR ATORNILLADOR EN
TORQUE FLACO.

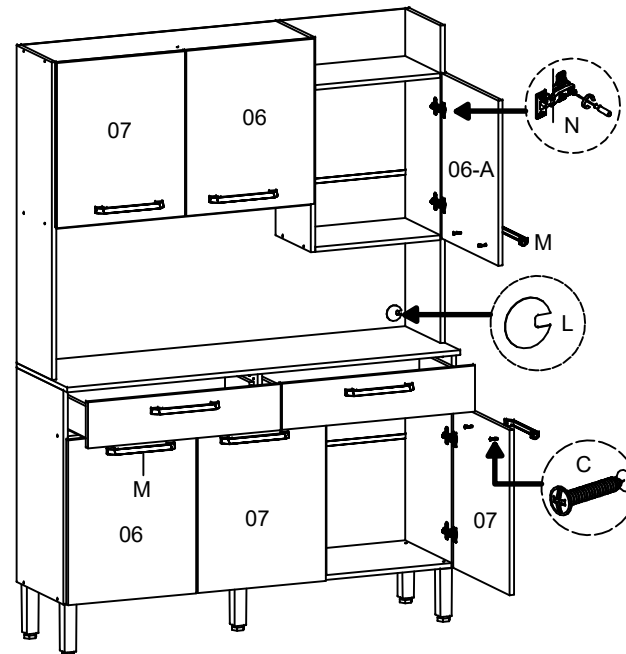

* LIMITE DE PESO MÁXIMO SUPORTADO (KG).
WEIGHT CAPACITY (KG).
CAPACIDAD DE PESO (KG).

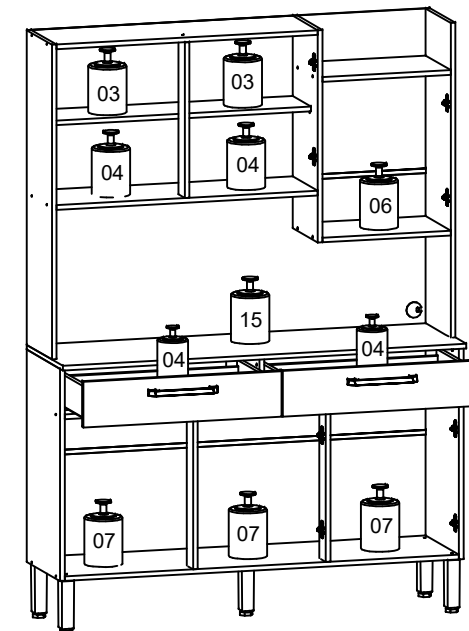

- CONSIDERAR UM PESO BEM DISTRIBUÍDO POR TODO O PRODUTO.
- CONSIDER A WELL DISTRIBUTED WEIGHT IN ALL THE PRODUCT.
- CONSIDERAR UN PESO BIEN DISTRIBUIDO EN TODO EL PRODUCTO.