

Nº	CÓDIGO	NOME DA PEÇA / NAME OF THE PIECE / NOMBRE DE LA PIEZA	MEDIDA	QTDE	MAT. PRIMA
01	100217.1210.0307	TRASEIRO INFERIOR / LOWER BOTTOM / TRASERO INFERIOR	1210x307x03	02	MADEFIBRA
02	100500.1590.0243	LATERAL DIREITA / RIGHT LATERAL / LATERAL DERECHA	1590x243x12	01	MDP
03	100504.0630.0092	COMPLEMENTO ESQUERDO / LEFT SMALL LATERAL / COMPLEMENTO IZQUIERDO	630x92x12	01	MDP
04	100209.0205.0243	DIVISÃO / DIVISION / DIVISIÓN	205x243x12	02	MDP
05	100210.0540.0080	CONTRA FUNDO DE GAVETA / DRAWER BOTTOM BOARD / CONTRA FONDO DE CAJÓN	540x80x12	02	MDP
06	100216.0597.0145	FRENTE DE GAVETA / DRAWER FRONT / FRENTE DEL CAJÓN	597x145x15	02	MDP
07	100213.0305.0562	FUNDO DE GAVETA / DRAWER BOTTOM / FONDO DEL CAJÓN	305x562x03	02	MADEFIBRA
08	100505.1590.0243	LATERAL ESQUERDA / LEFT LATERAL / LATERAL IZQUIERDA	1590x243x12	01	MDP
09	100506.0630.0092	COMPLEMENTO DIREITO / RIGHT SMALL LATERAL / COMPLEMENTO DERECHO	630x92x12	01	MDP
10	100218.1190.0243	PRATELEIRA II / SHELF II / REPISA II	1190x243x12	01	MDP
11	100219.1190.0335	BASE II / BASE II / BASE II	1190x335x12	01	MDP
12	100474.0603.0070	BATENTE II FRONTAL / FRONTAL DOORPOST II / DIVISIÓN II FRONTAL	603x70x15	01	MDP
13	100475.0603.0100	BATENTE II TRASEIRO / BOTTOM DOORPOST II / DIVISIÓN II TRASERO	603x100x15	01	MDP
14	104667.1190.0360	TAMPO / COVER / TAPA	1190x360x15	01	MDP
15	100220.1210.0217	TRASEIRO INTERM. / INTERMEDIARY BOTTOM / TRASERO INTERMEDIARIO	1210x217x03	01	MADEFIBRA
16	100503.1210.0298	TRASEIRO CENTRAL / CENTER BOTTOM / TRASERO CENTRAL	1210x298x03	01	MADEFIBRA
17	100139.0433.0060	BATENTE SUPERIOR / UPPER DOORPOST I / DIVISIÓN SUPERIOR	433x60x12	02	MDP
18	100140.0450.0297	PORTA DIREITA SUPERIOR / UPPER RIGHT DOOR / PUERTA DERECHA SUPERIOR	450x297x15	01	MDP
19	100141.0450.0297	PORTA ESQUERDA SUPERIOR / UPPER LEFT DOOR / PUERTA IZQUIERDA SUPERIOR	450x297x15	01	MDP
20	100366.1190.0243	CHAPÉU / HAT / CUBIERTA	1190x243x12	01	MDP
21	100507.1210.0450	TRASEIRO / BOTTOM / TRASERO	1210x450x03	01	MADEFIBRA
22	100120.0300.0100	LATERAL DE GAVETA / LATERAL OF DRAWER / LATERAL DEL CAJÓN	300x100x12	04	MDP
23	100223.1190.0243	BASE I / BASE I / BASE I	1190x243x12	01	MDP
24	101003.0670.0301	PORTA DE VIDRO / GLASS DOOR / PUERTA DE VIDRIO	670x301x15	02	MDP / VIDRO
25	100147.0460.0297	PORTA DIREITA INFERIOR / LOWER RIGHT DOOR / PUERTA DERECHA INFERIOR	460x297x15	02	MDP
26	100148.0460.0297	PORTA ESQUERDA INFERIOR / LOWER LEFT DOOR / PUERTA IZQUIERDA INFERIOR	460x297x15	02	MDP
27	100352	ACESSÓRIO DE MONT. / ASSEMBLY ACCESSORY / ACCESORIO DE MONT.	-	01	DIVERSOS
28	904990	PÉS / FEET / PATA	-	05	PLÁSTICO
29	900260	CORREDIÇA (PAR) / SLIDING (EQUAL) / CORREDERA (PAR)	300MM	02	METAL
30	903362	PERFIL H 1190MM / PLASTIC PROFILE "H" 1190MM / PERFIL "H" 1190 MM	1190MM	01	PLÁSTICO

CÓDIGOS IDENTIFICADOS NO TOPO DA MAIORIA DAS PEÇAS DO PRODUTO.
THESE CODES ARE IDENTIFIED ON THE SIDE OF MOST PARTS OF THE PRODUCT.
CÓDIGO IMPRESO EN EL CANTO CRUDO DE LA MAYORIA DE LAS PIEZAS.

LISTA DE ACESSÓRIO / ACCESSORY LIST / LISTAJE DE ACCESORIO			
1X1			
	A 32 911268 - PARAF. 3,5X12 CABEÇA 6.1		E 90 904801 - PREGO 09X09
	B 20 903540 - PARAF. 3,5X25 C/PONTA FLANGEADO		F 08 904803 - PREGO 12X12
	C 05 903557 - PARAF. 5,0X35 FLANGEADO		G 50 900198 - CAVILHA 6X25
	D 30 903542 - PARAF. 3,5X40		H 04 900205 - CAVILHA FSTRIADA

LISTA DE ACESSÓRIO / ACCESSORY LIST / LISTAJE DE ACCESORIO

	I 08 904982 - KIT DOBRADIÇA ALTA C/2
	J 10 911132 - PUXADOR
	K 21 900456 - FIXADOR P/ FUNDO
	L 04 900183 - CANTONEIRA DE GAVETA
	M 01 900243 - COLA

ESTRUTURA
STRUCTURE
ESTRUCTURA

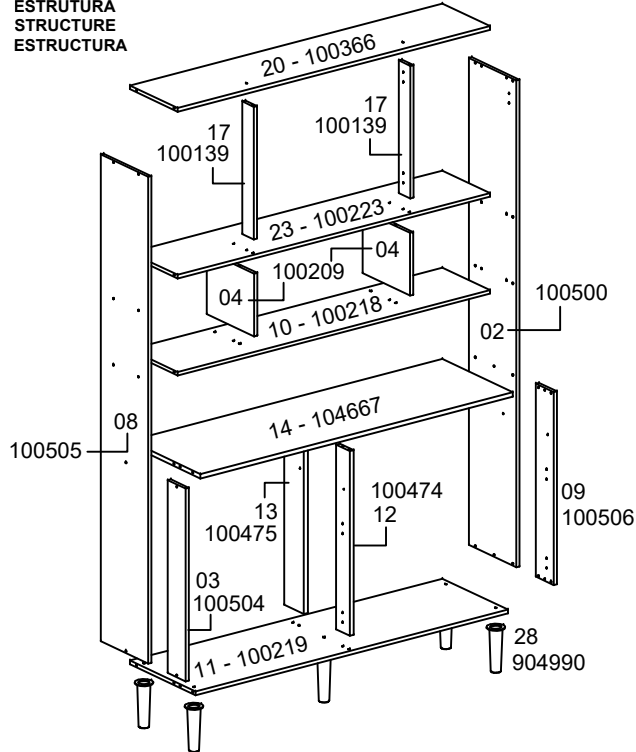

FRENTE
FRONT
FRENTE

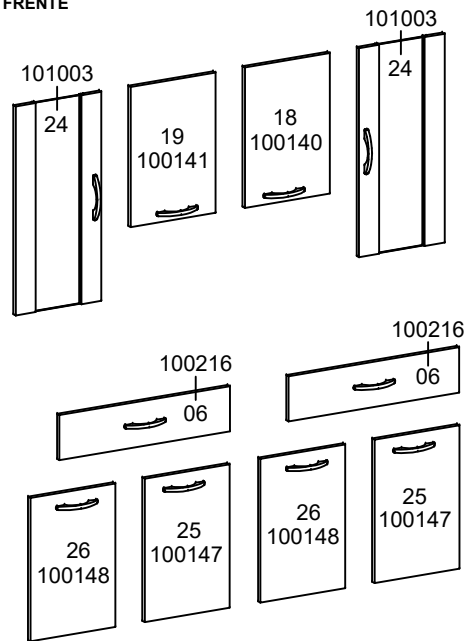

TRASEIRO
BOTTOM
TRASERO

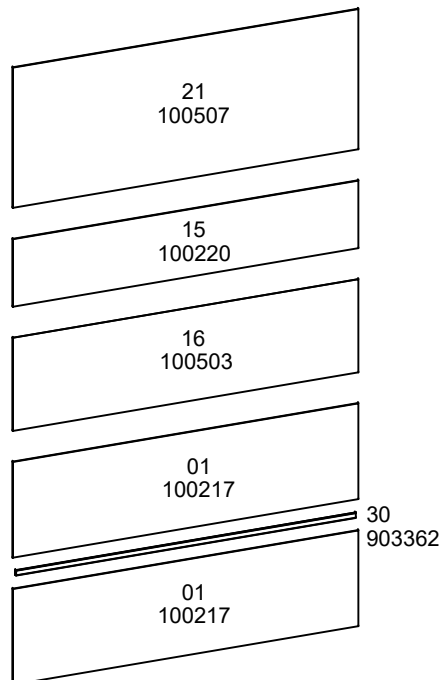

GAVETA
DRAWER
CAJÓN

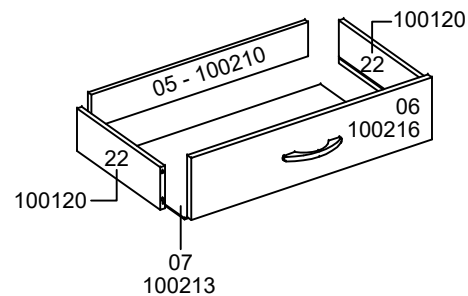

- PESSOAS NECESSÁRIAS P/ MONTAGEM.
- REQUIRED PEOPLE FOR ASSEMBLY.
- CANTIDAD DE PERSONAS NECESSARIAS P/ ARMAR.



ATENÇÃO / ATTENTION / ATENCIÓN:

- A LIMPEZA DO MÓVEL DEVE SER EFETUADA SOMENTE COM PANO MACIO E MODERADAMENTE UMEDECIDO COM ÁGUA PURA OU SOLUÇÃO COM SABÃO NEUTRO.
- FOR CLEANING, USE ONLY A SOFT CLOTH MODERATELY MOISTENED WITH PURE WATER OR A SOLUTION WITH NEUTRAL SOAP.
- PARA LIMPIEZA DEL MUEBLE USAR UN PAÑO SUAVE Y MODERADAMENTE HUMEDECIDO CON AGUA PURA O SOLUCIÓN CON JABÓN NEUTRO.
- NÃO UTILIZE PRODUTOS QUÍMICOS OU ABRASIVOS, TAIS COMO: CERA, ÁLCOOL, DETERGENTES, TINNER.
- DO NOT USE CHEMICAL OR ABRASIVE PRODUCTS. FOR EXAMPLE: WAX, ALCOHOL, DETERGENT, THINNER.
- NO APLICAR PRODUCTOS QUÍMICOS O ABRASIVOS TALES COMO: CERAS, ALCOHOL, DISOLVENTES O DETERGENTES.
- AO SOLICITAR ASSISTÊNCIA TÉCNICA, INFORME O CÓDIGO DO PRODUTO, A COR E O CÓDIGO DA PEÇA CORRETAMENTE.
- WHEN REQUESTING TECHNICAL ASSISTENCE, INFORM THE PRODUCT CODE, THE COLOR AND THE PIECE CODE CORRECTLY.
- SI NECESITAR REPUESTOS, INFORMAR EL CÓDIGO DEL PRODUCTO, EL COLOR Y EL CÓDIGO DE LA PIEZA.

FERRAMENTAS NECESSÁRIAS P/ MONTAGEM.
(NÃO SÃO FORNECIDAS)
REQUIRED TOOLS FOR ASSEMBLY.
(NOT PROVIDED)
HERRAMIENTAS NECESSARIAS.
(NO PROPORCIONADAS)

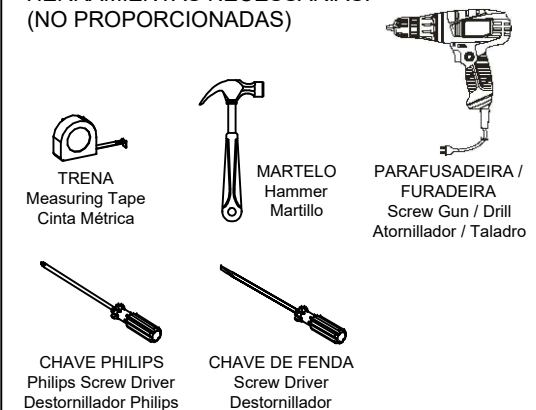

① COLOCAÇÃO DO KIT DOBRADIÇA.
HINGE SET PLACEMENT.
COLOCACIÓN DEL KIT BISAGRA.

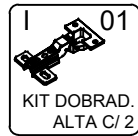
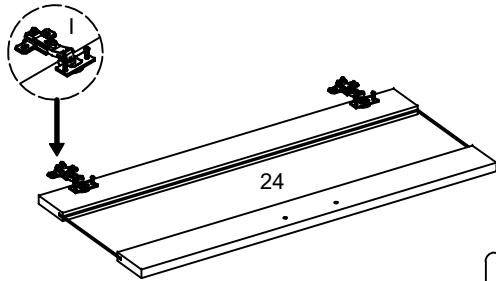

② MONTAGEM DAS GAVETAS.
DRAWERS ASSEMBLY.
MONTAJE DE LOS CAJONES.

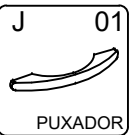
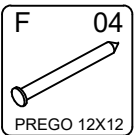
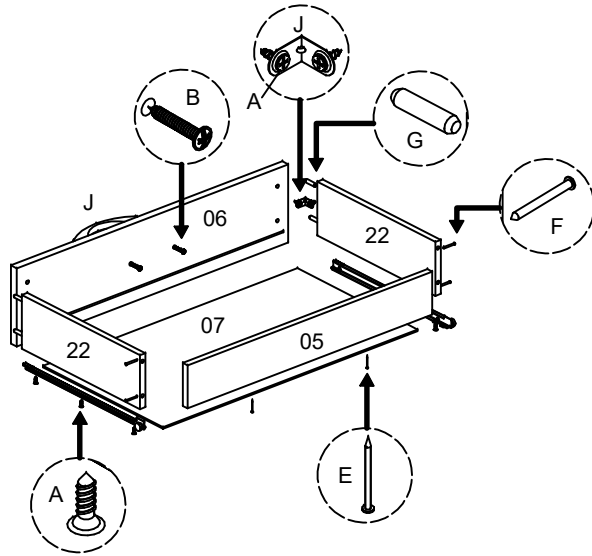

③ MONTAGEM DA ESTRUTURA.
STRUCTURE ASSEMBLY.
MONTAJE DE LA ESTRUCTURA.

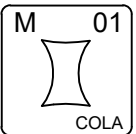
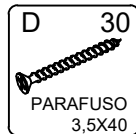
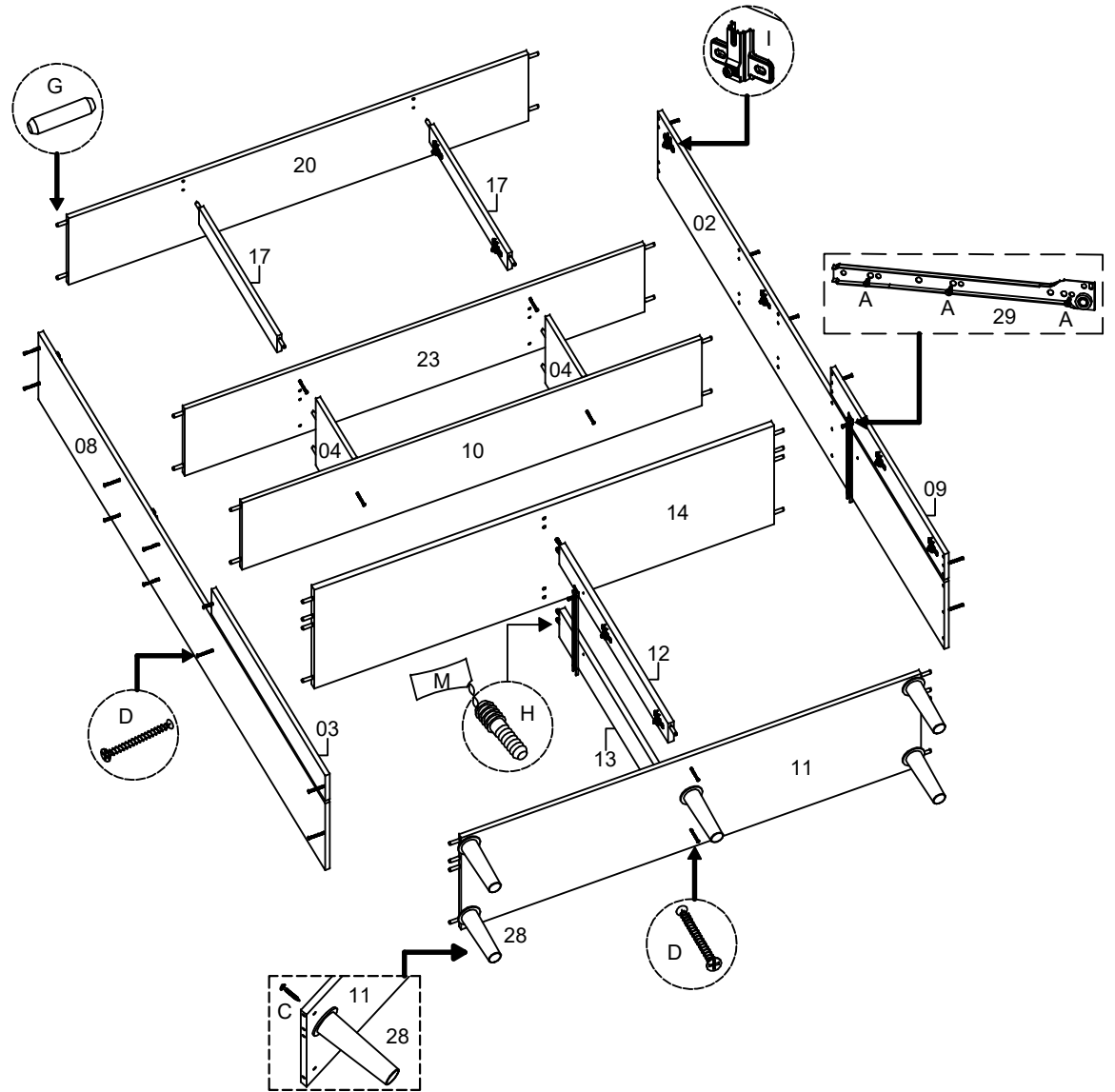

④ **FIXAÇÃO DOS TRASEIROS.**
BOTTOMS ATTACHMENT.
FIJACIÓN DE LOS TRASEROS.

- TIRAR ESQUADRO: MEDIR EM CRUZ PELOS CANTOS DO PRODUTO.
- SQUARING: MEASURE THE OPPOSITE CORNERS OF THE PRODUCT IN CROSSWISE.
- ESCUADRAR: TOMAR LA MEDIDA ENTRE LAS EXTREMIDADES INVERSAS DEL PRODUCTO.

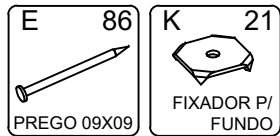
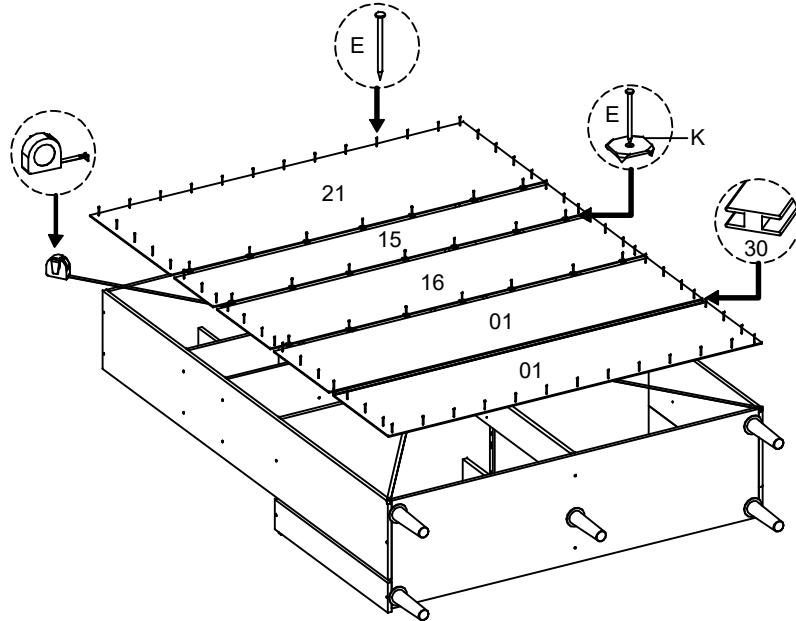

⑤ **COLOCAÇÃO DAS PORTAS E GAVETAS.**
DOORS AND DRAWERS PLACEMENT.
COLOCACIÓN DE LAS PUERTAS Y CAJONES.

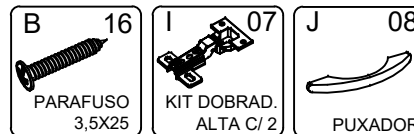
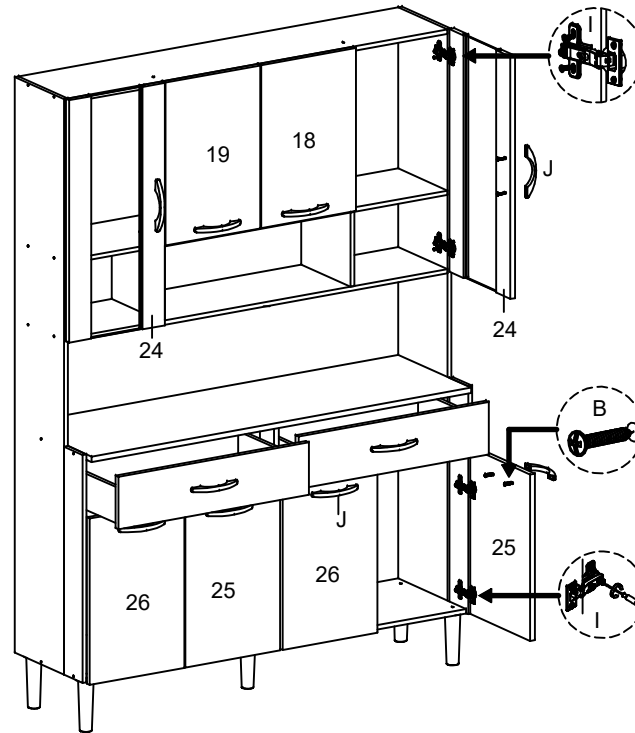

- INFORMAÇÃO AO MONTADOR:
USAR PARAFUSADEIRA NO TORQUE BAIXO!
- INFORMATION TO THE ASSEMBLER:
USE THE CORDLESS DRILL AT LOW TORQUE.
- INFORMACIÓN AL ARMADOR:
UTILIZAR ATORNILLADOR EN TORQUE FLACO.

* LIMITE DE PESO MÁXIMO SUPORTADO (KG).
 WEIGHT CAPACITY (KG).
 CAPACIDAD DE PESO (KG).

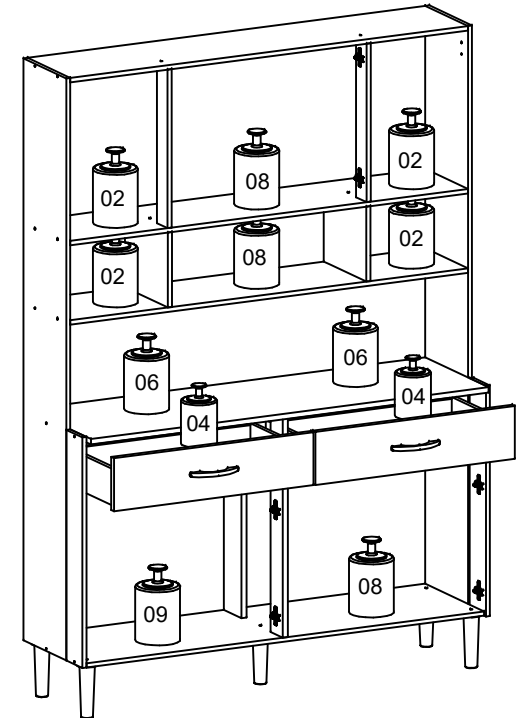

- CONSIDERAR UM PESO BEM DISTRIBUÍDO POR TODO O PRODUTO.
- CONSIDER A WELL DISTRIBUTED WEIGHT IN ALL THE PRODUCT.
- CONSIDERAR UN PESO BIEN DISTRIBUIDO EN TODO EL PRODUCTO.