

ASSEMBLY INSTRUCTIONS MANUAL DE MONTAGEM / INSTRUCCIONES DE ARMADO

3-DOOR GLASS WALL CABINET
AEREO 3 PORTAS DE VIDRO
GABINETE DE PARED CON 3 PUERTAS DE VIDRO

Reference
Referência
Referencia **250302** | Revise
Revisão
Revisión **00**

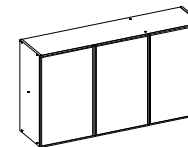

YOU WILL NEED VOCÊ VAI PRECISAR DE / USTED NECESITARÁ

Tools not supplied
Ferramentas não fornecidas / Herramientas no incluidas

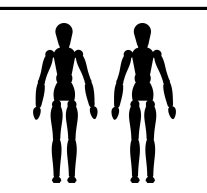

2 People
2 Pessoas
2 Personas

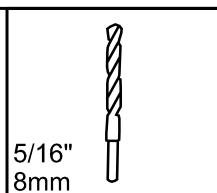

Drill bit
Broca
Taladro

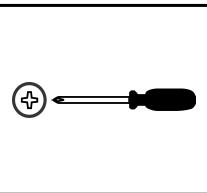

Screwdriver Phillips
Chave Phillips
Destornillador cruz

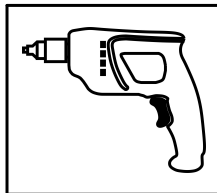

Drill machine
Furadeira
Taladro

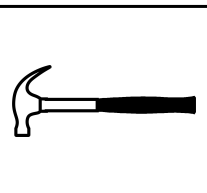

Hammer
Martelo
Martillo

 MAXIMUM RECOMMENDED WEIGHT BEING THIS EVENLY DISTRIBUTED.
PESO MÁXIMO RECOMENDADO SENDO ESTE DISTRIBUÍDO UNIFORMEMENTE.
PESO MÁXIMO RECOMENDADO SIENDO ESTE UNIFORMEMENTE DISTRIBUIDO.

	LB	KG
—		
F	22	10

PARTS IDENTIFICATION IDENTIFICAÇÃO DAS PEÇAS / IDENTIFICACIÓN DE LAS PIEZAS

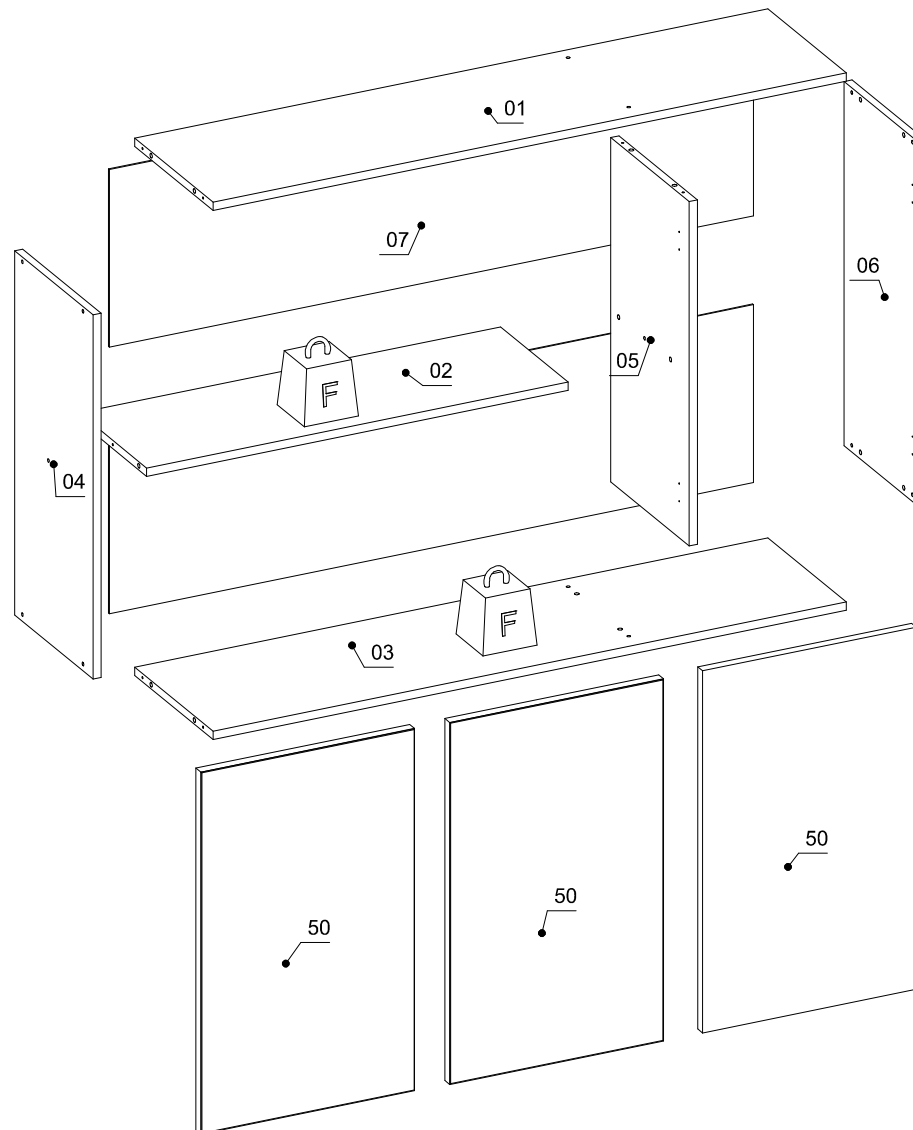

Nº	Measures_Inches	Medidas_cm	Qty./Qtd.
01	46 1/8 x 11 3/8 x 5/8	117.0 x 29.0 x 1.5	1
02	30 5/8 x 9 7/8 x 5/8	77.9 x 25.0 x 1.5	1
03	46 1/8 x 11 3/8 x 5/8	117.0 x 29.0 x 1.5	1
04	26 x 11 3/8 x 5/8	66.0 x 29.0 x 1.5	1
05	24 5/8 x 11 3/8 x 5/8	62.4 x 29.0 x 1.5	1
06	26 x 11 3/8 x 5/8	66.0 x 29.0 x 1.5	1
07	46 7/8 x 12 5/8 x 1/8	119.0 x 32.2 x 0.3	2
50	25 7/8 x 15 1/2 x 3/4	65.6 x 39.5 x 1.8	3

IDENTIFICATION OF ACCESSORIES IDENTIFICAÇÃO DOS ACESSÓRIOS/ IDENTIFICACIÓN DE ACCESORIOS



The separation of the accessories before you start the assembly will facilitate the same. In case of doubt on the size of the screws and bolts, use the ruler at the bottom of the page.
 A separação dos acessórios antes de iniciar a montagem facilitará a mesma. Em caso de dúvida no tamanho dos parafusos e cavilhas, utilize a régua ao final da página.
 La separación de los accesorios antes de comenzar el armado facilitará el mismo. En caso de duda sobre el tamaño de los tornillos y taquetes, utilice la regla al pie de página.

A		Flanged head screw Parafuso flangeado / Tornillo de cabeza flangeada	5,0x60 mm	3
B3		Bushing Bucha expansiva / Tapón	8x50 mm	3
C1		Metal claw Garra de metal / Garra metal	-	4
D5		Hinge shim Calço dobradiça / Bisagra de calce	-	6
E		Wooden dowel Cavilha / Taquete	8x30 mm	16
F6		Metal hinge curve Dobradiça curva / Esquina de bisagra metálica	26 mm	2
F9		Metal hinge straight Dobradiça reta / Bisagra recta	26 mm	4
N		Nail Prego / Clavo	10x10	44
N5		Support "L" Suporte "L" / Soporte "L"	-	3
O		Flat head screw Parafuso chato / Tornillo de cabeza plana	4,5x45 mm	14
S		Pan head screw Parafuso panela / Tornillo de pan	3,5x14 mm	30

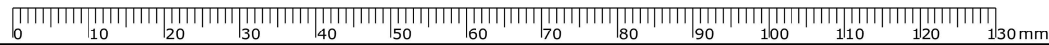

PRE-ASSEMBLE PRÉ-MONTAGEM / PRE ARMADO

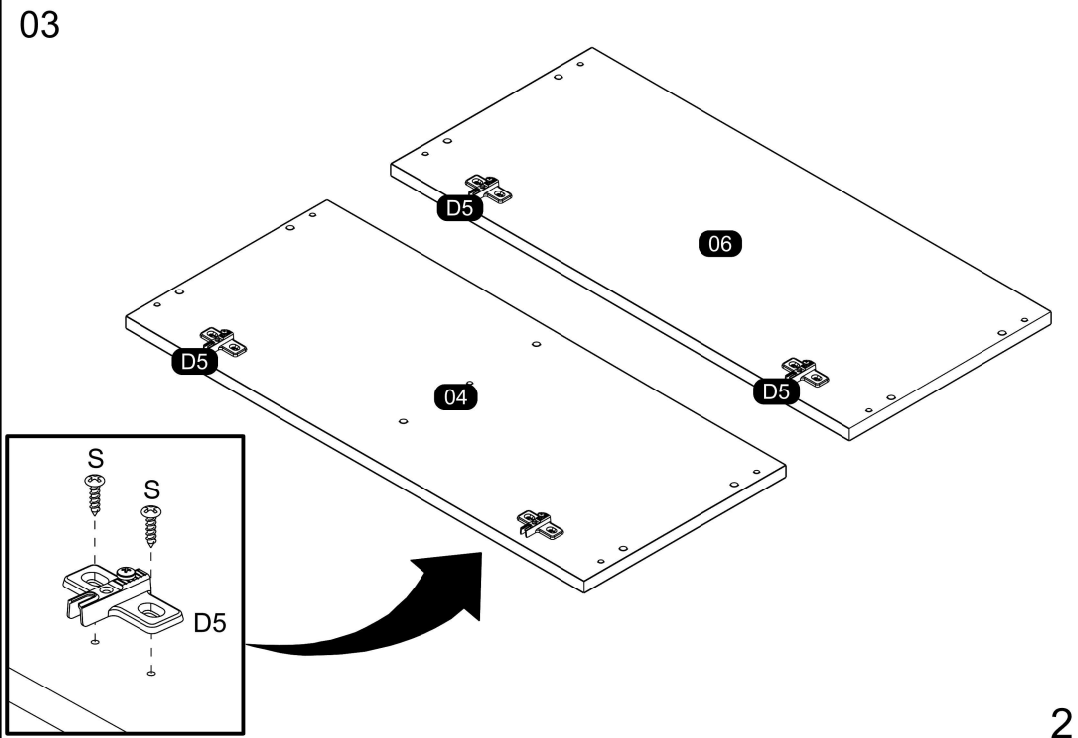
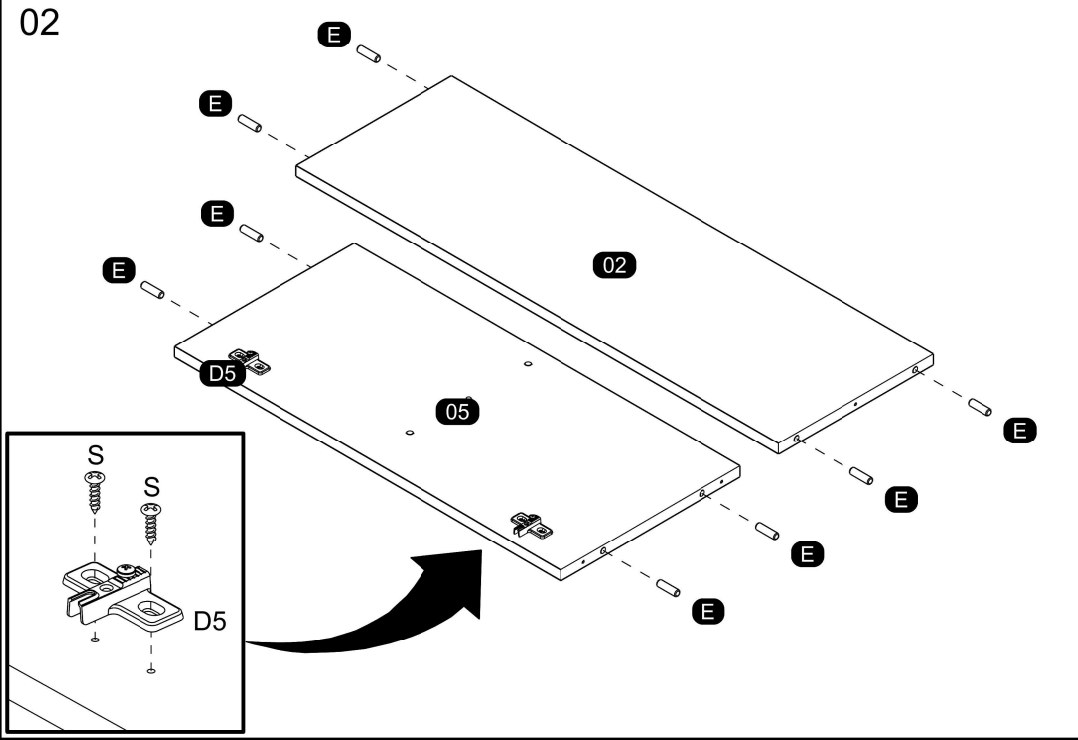
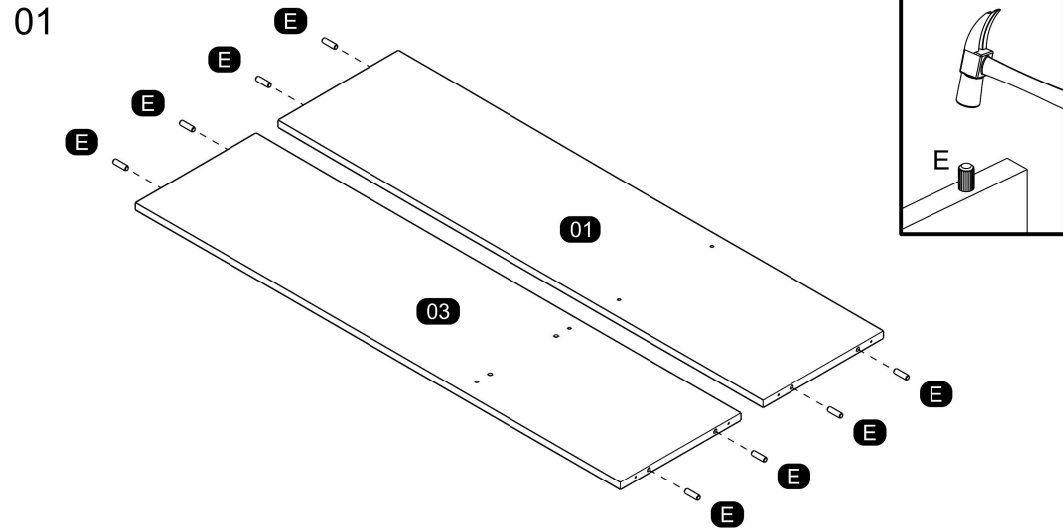

04

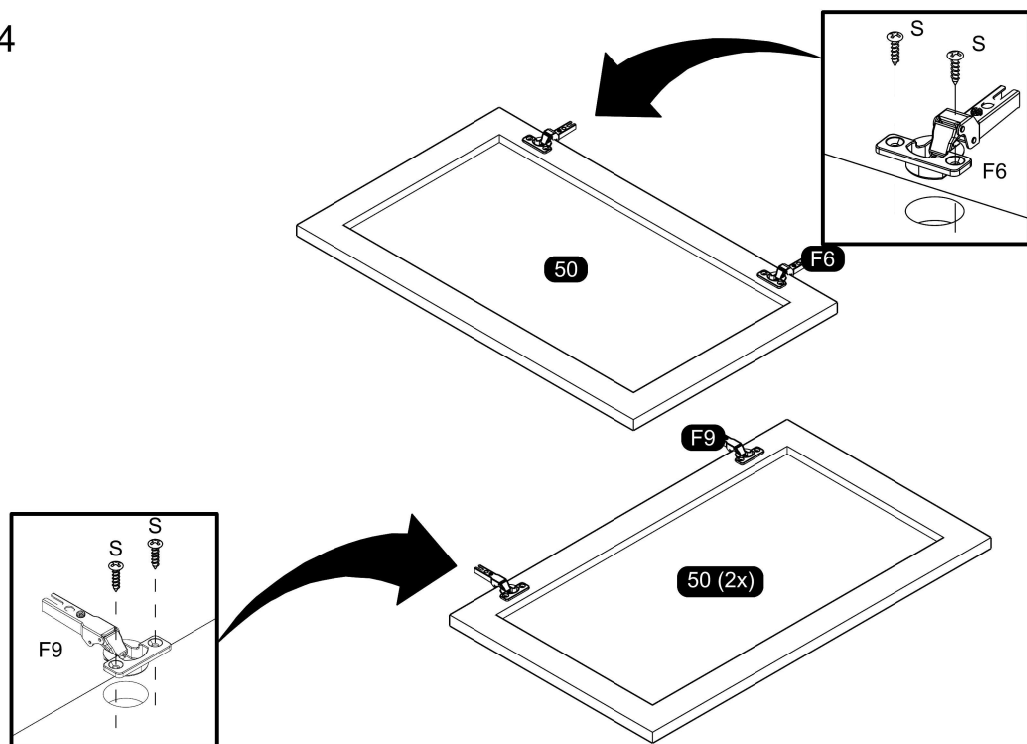

06

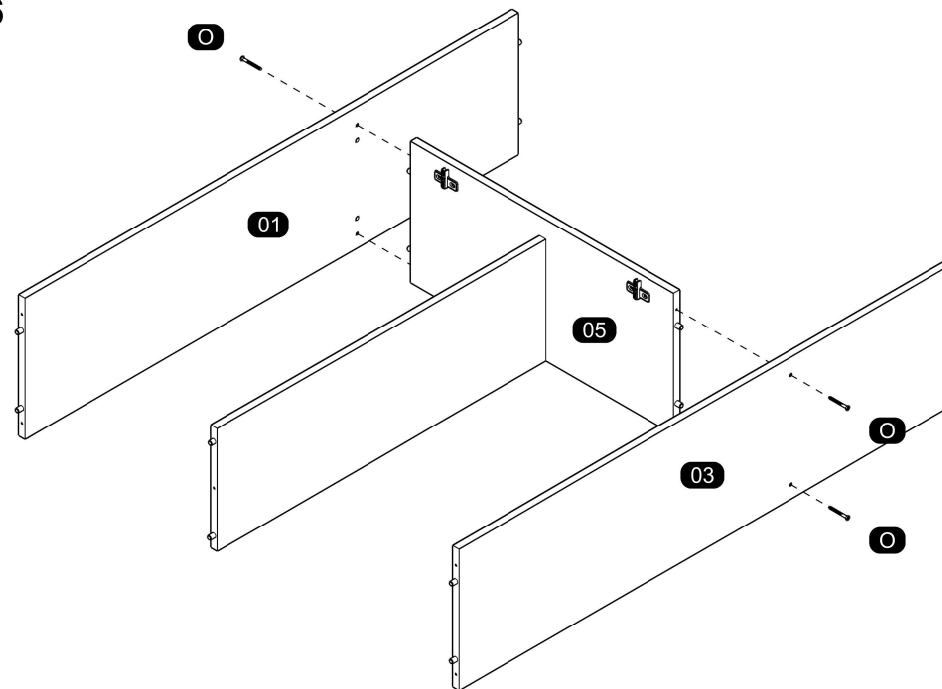

**ASSEMBLY
MONTAGEM / ARMADO**

05

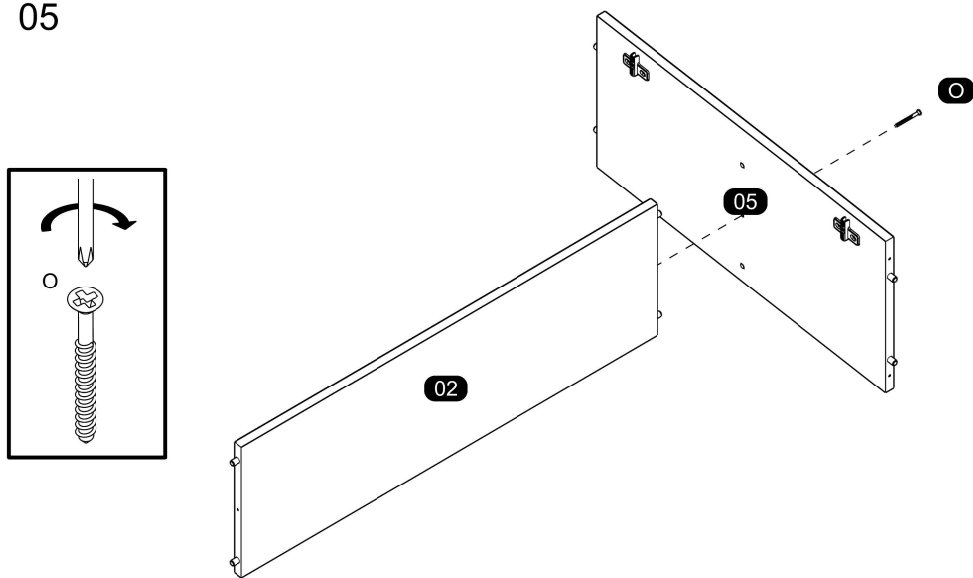

07

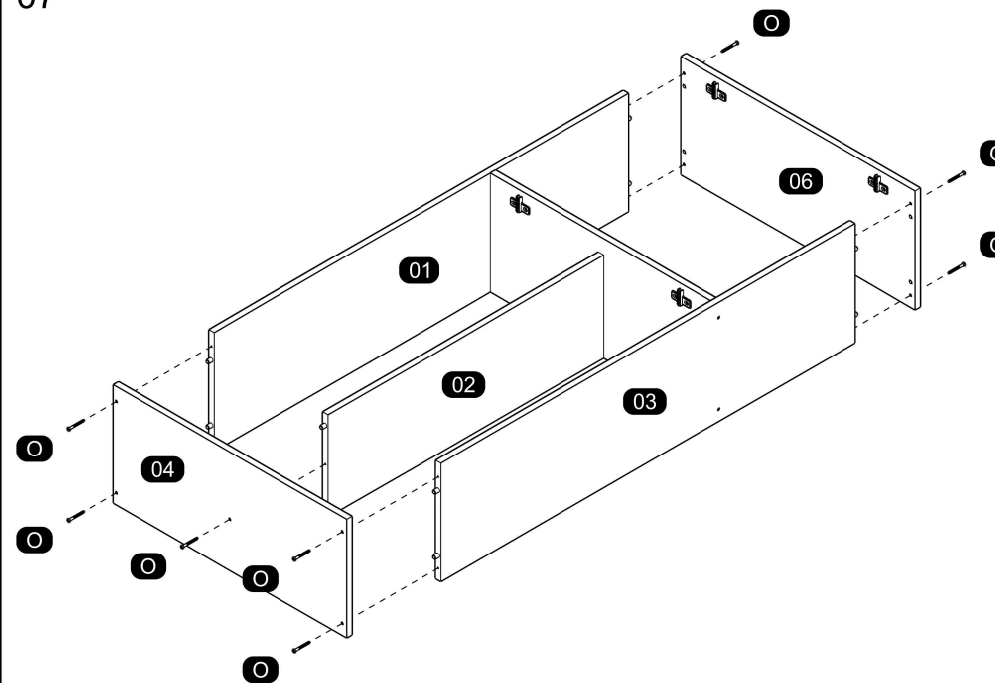

08

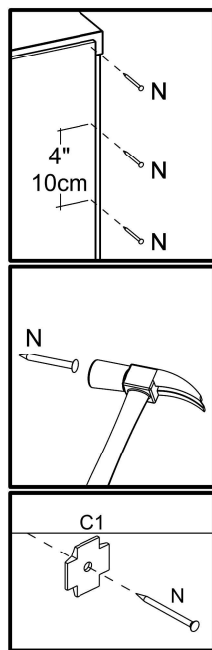
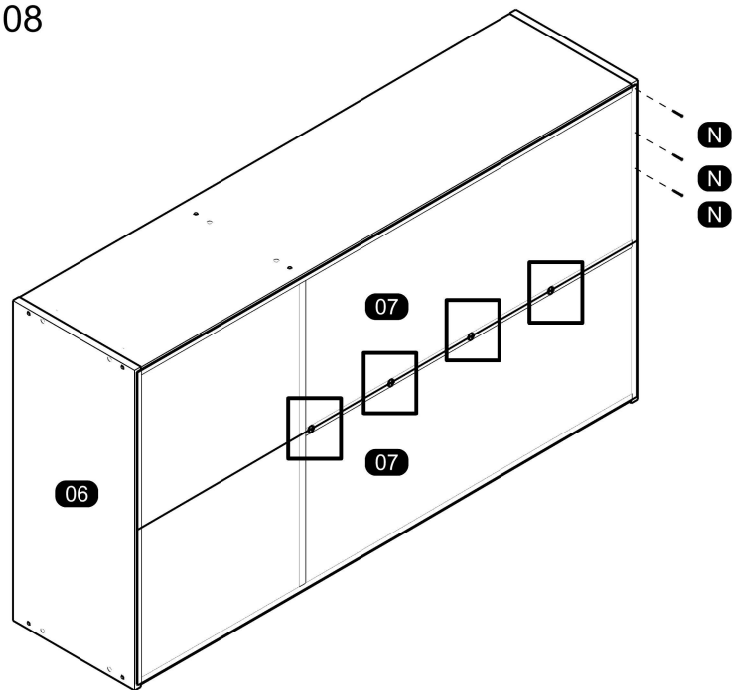

10

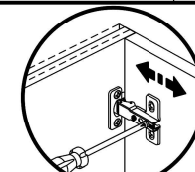
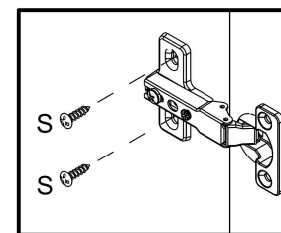
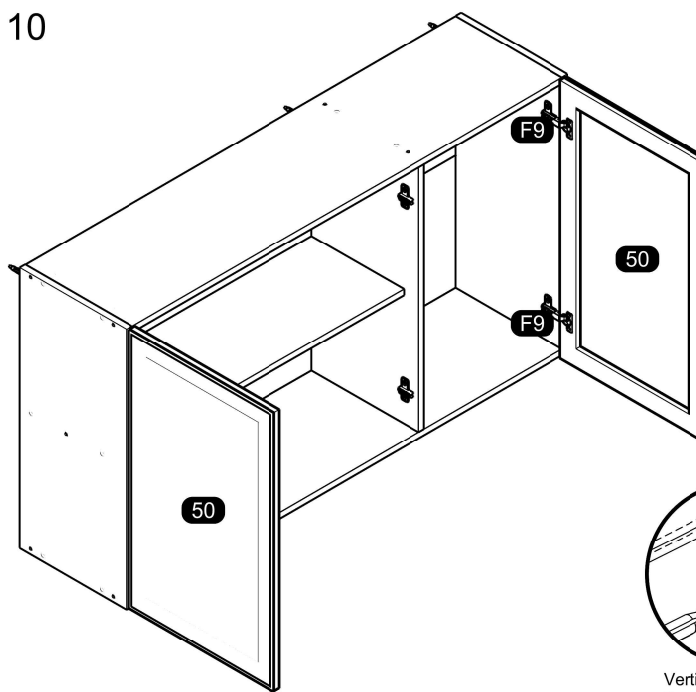

Depth Adjustment
Regulagem Profundidade
Ajuste Profundidade

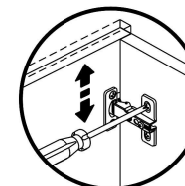

Vertical Adjustment
Regulagem Vertical
Ajuste Vertical

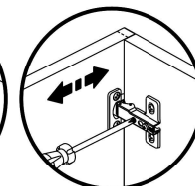

Horizontal Adjustment
Regulagem Horizontal
Ajuste Horizontal

09

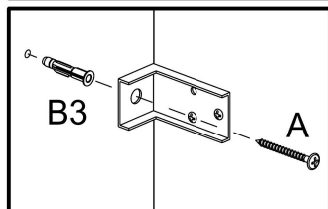
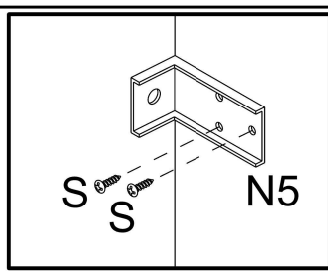
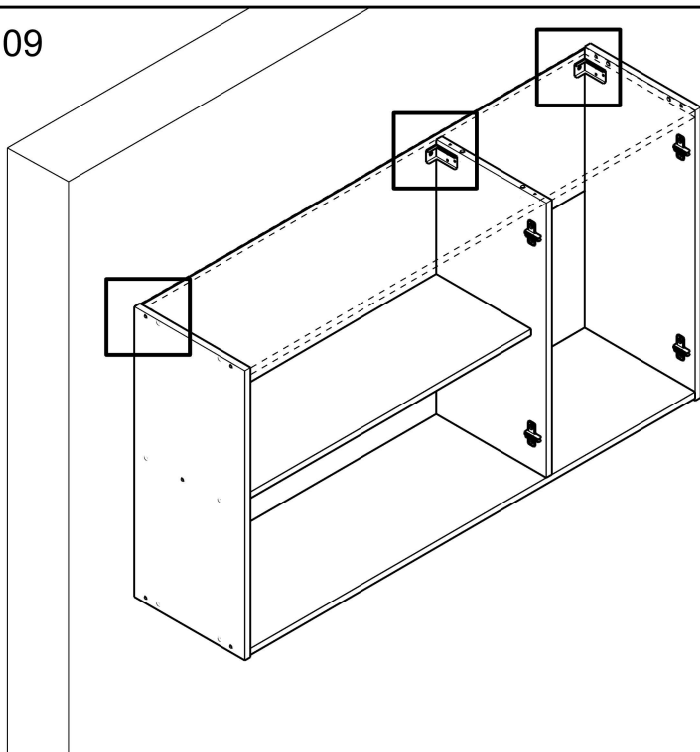

11

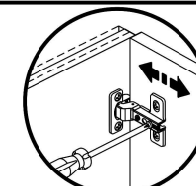
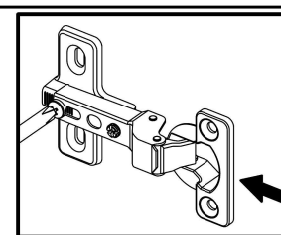
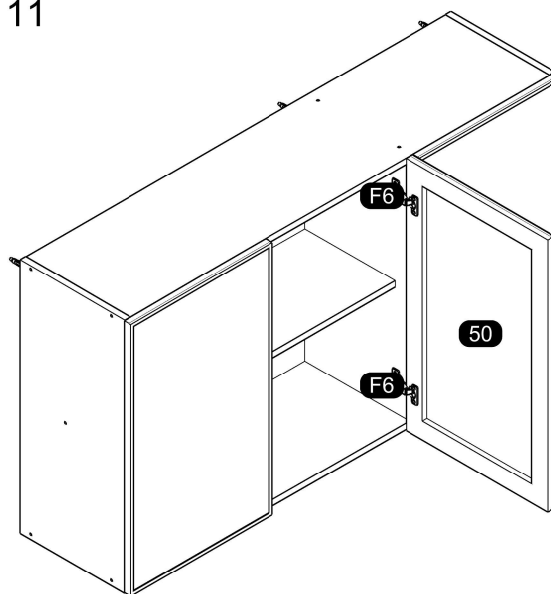

Depth Adjustment
Regulagem Profundidade
Ajuste Profundidade

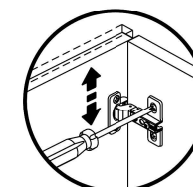

Vertical Adjustment
Regulagem Vertical
Ajuste Vertical

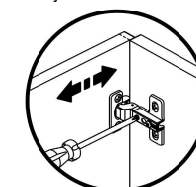

Horizontal Adjustment
Regulagem Horizontal
Ajuste Horizontal