

- PESSOAS NECESSÁRIAS P/ MONTAGEM.  
 - REQUIRED PEOPLE FOR ASSEMBLY.  
 - CANTIDAD DE PERSONAS NECESARIAS P/ ARMAR.



**LISTA DE PEÇAS / LIST OF PIECE / LISTAJE DE PIEZAS**

Nº	CÓDIGO	NOME DA PEÇA / NAME OF THE PIECE / NOMBRE DE LA PIEZA	MEDIDA	QTDE	MAT. PRIMA
01	115963	ACESSÓRIO DE MONTAGEM / ASSEMBLY ACCESSORY / ACCESORIO DE MONTAJE	-	01	DIVERSOS
02	116047.0360.0295	LATERAL DIREITA / RIGHT LATERAL / LATERAL DERECHA	360x295x15	01	MDF
03	116048.0360.0295	LATERAL ESQUERDA / LEFT LATERAL / LATERAL IZQUIERDA	360x295x15	01	MDF
04	116049.0770.0295	CHAPÉU / HAT / CUBIERTA	770x295x15	01	MDF
05	116050.0770.0295	BASE / BASE / BASE	770x295x15	01	MDF
06	116051.0762.0322	PORTA BASCULANTE / HORIZONTAL DOOR / PUERTA HORIZONTAL	762x322x15	01	MDF
07	116052.0795.0355	TRASEIRO / BOTTOM / TRASERO	795x355x03	01	MADEFIBRA

CÓDIGOS IDENTIFICADOS NO TOPO DA MAIORIA DAS PEÇAS DO PRODUTO.  
 THESE CODES ARE IDENTIFIED ON THE SIDE OF MOST PARTS OF THE PRODUCT.  
 CÓDIGO IMPRESO EN EL CANTO CRUDO DE LA MAYORIA DE LAS PIEZAS.

FERRAMENTAS NECESSÁRIAS P/ MONTAGEM.  
 (NÃO SÃO FORNECIDAS)  
 REQUIRED TOOLS FOR ASSEMBLY.  
 (NOT PROVIDED)  
 HERRAMIENTAS NECESARIAS.  
 (NO PROPORCIONADAS)

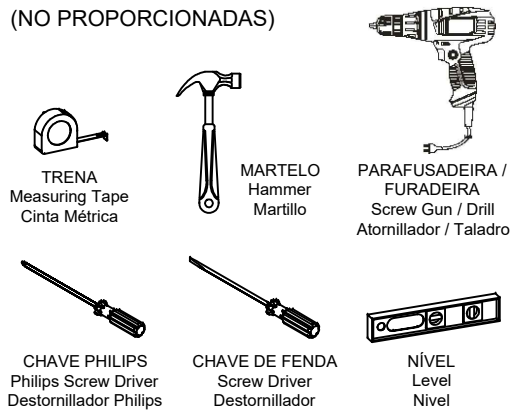

**LISTA DE ACESSÓRIO / ACCESSORY LIST / LISTAJE DE ACCESORIO - 1X1**

	<b>A 06</b>	911268 - PARAF. 3,5X12 CHATA PHS 6.1		<b>F 02</b>	903563 - PARAF. 6,0X50
	<b>B 02</b>	914127 - PARAFUSO 3,5X16		<b>G 04</b>	905126 - PORCA SEXTAVADA M4
	<b>C 04</b>	909192 - PARAF. 3,5X25 CABEÇA CHATA		<b>H 02</b>	900053 - BUCHA 08
	<b>D 04</b>	903571 - PARAF. M4X25		<b>I 20</b>	904801 - PREGO 09X09
	<b>E 08</b>	903566 - PARAF. 5,0x40		<b>J 08</b>	902913 - CAVILHA 8X30

**LISTA DE ACESSÓRIO / ACCESSORY LIST / LISTAJE DE ACCESORIO**

	<b>K 02</b>	903341 - FIXADOR L CANT. METÁLICA		<b>L 02</b>	901635 - FIXADOR L CAPA PLÁSTICA		<b>M 01</b>	905141 - KIT DOB. SUPER ALTA SLOW C/ 2
	<b>N 01</b>	900434 - SUPORTE A GÁS		<b>O 01</b>	913355 - PUXADOR		<b>P 02</b>	915242 - BATENTE DISTANCIADOR

**ESTRUTURA / STRUCTURE / ESTRUCTURA**

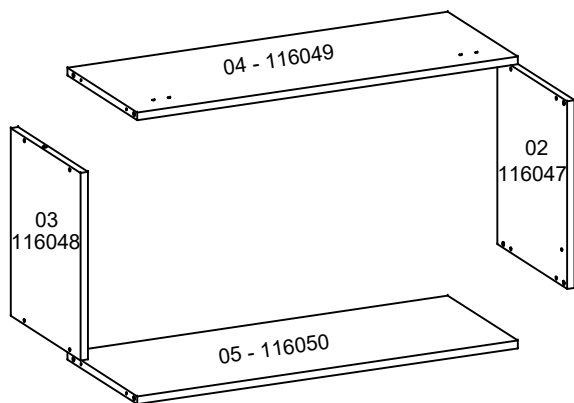

**TRASEIRO / BOTTOM / TRASERO**

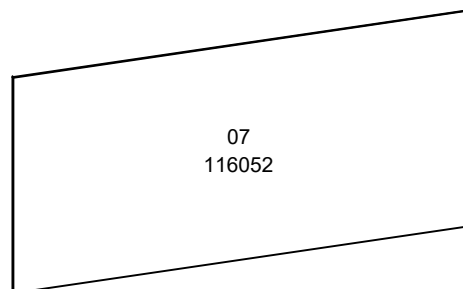

**FRENTE / FRONT / FRENTE**

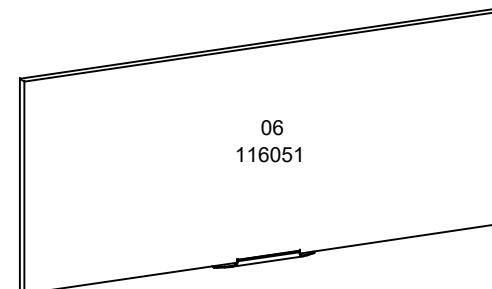

**ATENÇÃO / ATTENTION / ATENCIÓN:**

- A LIMPEZA DO MÓVEL DEVE SER EFETUADA SOMENTE COM PANO MACIO E MODERADAMENTE UMEDECIDO COM ÁGUA PURA OU SOLUÇÃO COM SABÃO NEUTRO.
- FOR CLEANING, USE ONLY A SOFT CLOTH MODERATELY MOISTENED WITH PURE WATER OR A SOLUTION WITH NEUTRAL SOAP.
- PARA LIMPIEZA DEL MUEBLE USAR UN PAÑO SUAVE Y MODERADAMENTE HUMEDECIDO CON AGUA PURA O SOLUCIÓN CON JABÓN NEUTRO.
- NÃO UTILIZE PRODUTOS QUÍMICOS OU ABRASIVOS, TAIS COMO: CERA, ÁLCOOL, DETERGENTES, TINNER.
- DO NOT USE CHEMICAL OR ABRASIVE PRODUCTS. FOR EXAMPLE: WAX, ALCOHOL, DETERGENT, THINNER.
- NO APLICAR PRODUCTOS QUÍMICOS O ABRASIVOS TALES COMO: CERAS, ALCOHOL, DISOLVENTES O DETERGENTES.
- AO SOLICITAR ASSISTÊNCIA TÉCNICA, INFORME O CÓDIGO DO PRODUTO, A COR E O CÓDIGO DA PEÇA CORRETAMENTE.
- WHEN REQUESTING TECHNICAL ASSISTENCE, INFORM THE PRODUCT CODE, THE COLOR AND THE PIECE CODE CORRECTLY.
- SI NECESITAR REPUESTOS, INFORMAR EL CÓDIGO DEL PRODUCTO, EL COLOR Y EL CÓDIGO DE LA PIEZA.

**① COLOCAÇÃO DAS DOBRADIÇAS E PUXADORES.  
 HINGE AND HANDLES ATTACHMENT.  
 FIJACIÓN DE LAS MANIJAS Y BISAGRA .**

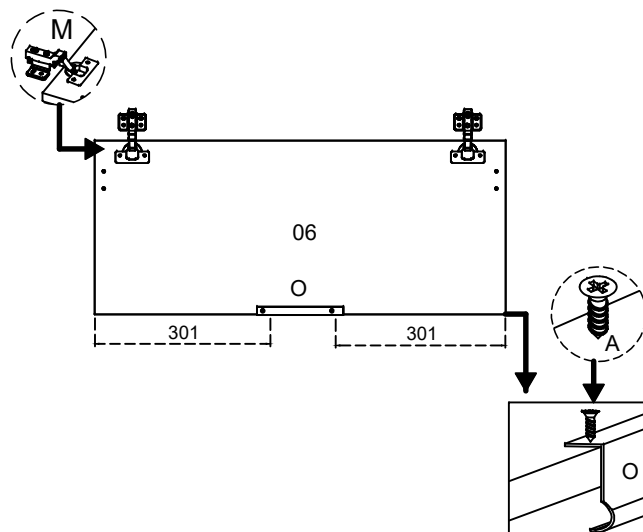

**② MONTAGEM DA ESTRUTURA.  
 STRUCTURE ASSEMBLY.  
 MONTAJE DE LA ESTRUCTURA.**

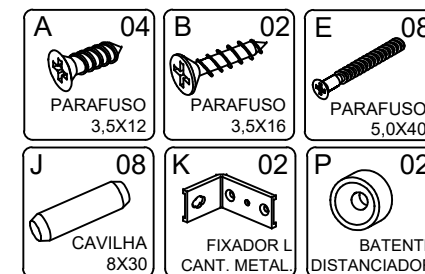
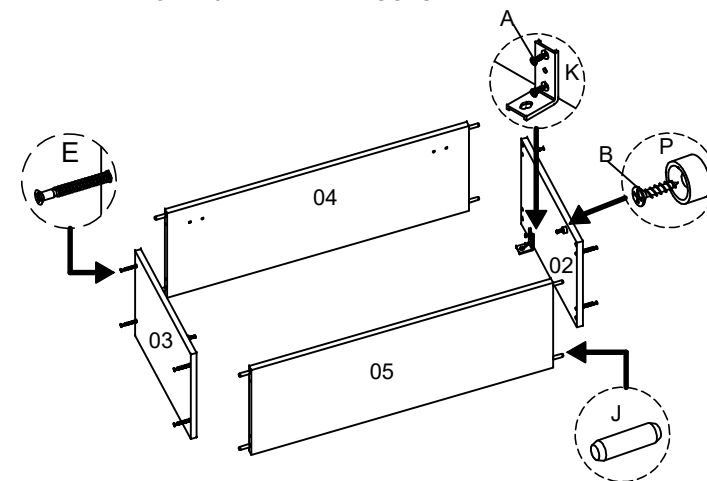

③ FIXAÇÃO DO TRASEIRO.  
 BOTTOM ATTACHMENT.  
 FIJACIÓN DEL TRASERO.

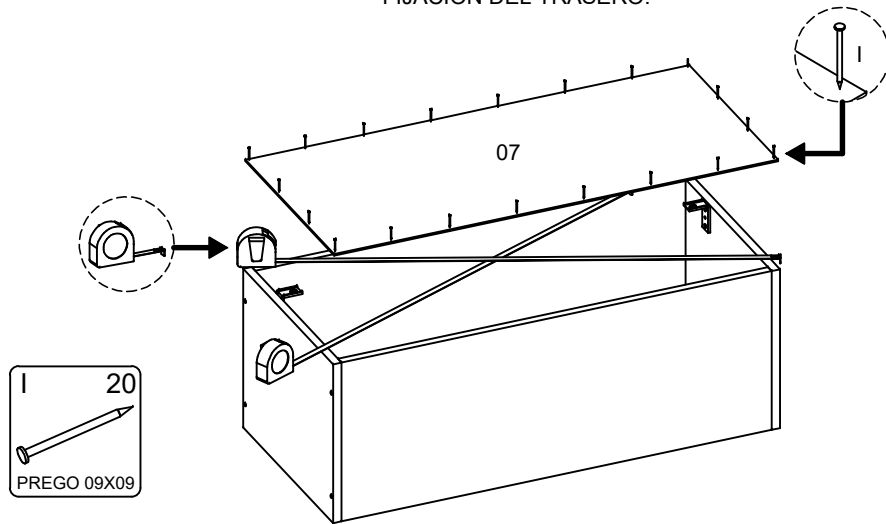

- TIRAR ESQUADRO: MEDIR EM CRUZ PELOS CANTOS DO PRODUTO.
- SQUARING: MEASURE THE OPPOSITE CORNERS OF THE PRODUCT IN CROSSWISE.
- ESCUADRAR: TOMAR LA MEDIDA ENTRE LAS EXTREMIDADES INVERSAS DEL PRODUCTO.

PARA UNIÃO DOS MÓDULOS, FAZER USO DO PARAF. 3,5X25 (B).  
 FOR THE MODULES UNION, USE SCREW 3,5X25 (B).  
 PARA LA UNIÓN DE LOS MÓDULOS, USE EL TORNILLO 3,5X25 (B).

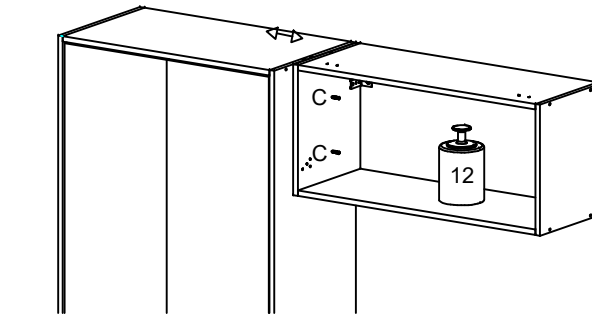

\* LIMITE DE PESO MÁXIMO SUPORTADO (KG).  
 \* WEIGHT CAPACITY (KG).  
 \* CAPACIDAD DE PESO (KG).



- CONSIDERAR UM PESO BEM DISTRIBUÍDO POR TODO O PRODUTO.
- CONSIDER A WELL DISTRIBUTED WEIGHT IN ALL THE PRODUCT.
- CONSIDERAR UN PESO BIEN DISTRIBUIDO EN TODO EL PRODUCTO.

④ COLOCAÇÃO DA PORTA BASCULANTE.  
 HORIZONTAL DOOR PLACEMENT.  
 COLOCACIÓN DE LA PUERTA HORIZONTAL.

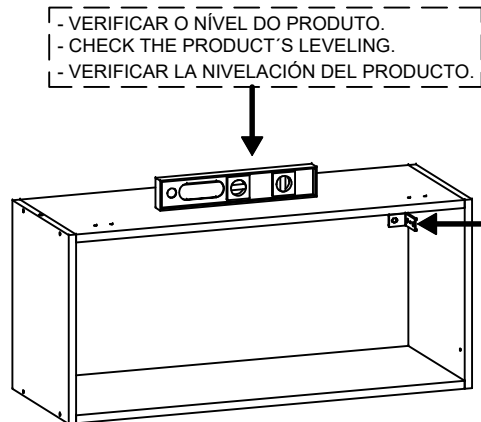

- INFORMAÇÃO AO MONTADOR: USAR PARAFUSADEIRA NO TORQUE BAIXO!
- INFORMATION TO THE ASSEMBLER: USE THE CORDLESS DRILL AT LOW TORQUE.
- INFORMACIÓN AL ARMADOR: UTILIZAR ATORNILLADOR EN TORQUE FLACO.

