

ASPECTO MONTADO / ASSEMBLY ASPECT / ASPECTO LISTO

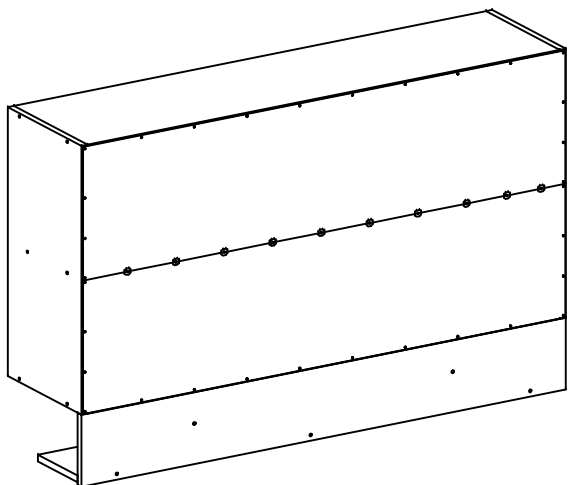

ASPECTO TRASEIRO / BOTTOM ASPECT / ASPECTO TRASERO

- PESSOAS NECESSÁRIAS PARA MONTAGEM.
- REQUIRED PEOPLE FOR ASSEMBLY.
- CANTIDAD DE PERSONAS NECESARIAS P/ ARMAR.



2 PESSOAS
2 PEOPLE
2 PERSONAS

LISTA DE PEÇAS / LIST OF PIECE / LISTAJE DE PIEZA					
Nº	COD	NOME DA PEÇA / NAME OF THE PIECE / NOMBRE DE LA PIEZA	MEDIDA	QTDE	MAT. PRIMA
VOLUME 01					
01	115955	ACESSÓRIO DE MONTAGEM / ASSEMBLY ACCESSORY / ACCESORIO DE MONTAJE	-	01	DIVERSOS
02	116020.0600.0295	LATERAL DIREITA / RIGHT LATERAL / LATERAL DERECHA	600x295x15	01	MDF
03	116021.0600.0295	LATERAL ESQUERDA / LEFT LATERAL / LATERAL IZQUIERDA	600x295x15	01	MDF
04	116035.1170.0295	CHAPÉU / HAT / CUBIERTA	1170x295x15	01	MDF
05	116036.1170.0295	BASE / BASE / BASE	1170x295x15	01	MDF
06	116037.0562.0581	PORTA DIR-ESQ / RIGHT-LEFT DOOR / PUERTA DER-IZQ	562x581x15	02	MDF
07	116038.1170.0278	PRATELEIRA / SHELF / REPISA	1170x278x15	01	MDF
08	116039.1200.0160	SUPORTE TRASEIRO / BOTTOM SUPPORT / APOYO TRASERO	1200x160x15	01	MDF
09	116040.1200.0160	PRATELEIRA NICHU / NICHE SHELF / REPISA DEL NICHU	1200x160x15	01	MDF
10	116041.0277.0277	DIVISÃO / DIVISION / DIVISIÓN	277x277x15	01	MDF
11	110236.1195.0298	TRASEIRO / BOTTOM / TRASERO	1195x298x03	02	MADEFIBRA

CÓDIGOS IDENTIFICADOS NO TOPO DA MAIORIA DAS PEÇAS DO PRODUTO.
THESE CODES ARE IDENTIFIED ON THE SIDE OF MOST PARTS OF THE PRODUCT.
CÓDIGO IMPRESO EN EL CANTO CRUDO DE LA MAYORIA DE LAS PIEZAS.

LISTA DE ACESSÓRIO / ACCESSORY LIST / LISTAJE DE ACCESORIO - 1X1		
		A 12 911268 - PARAF. 3,5X12 CABEÇA CHATA 6,1
		B 04 909192 - PARAF. 3,5X25
		C 19 903566 - PARAF. 5,0X40
		D 06 903563 - PARAF. 6,0X50
		E 42 904801 - PREGO 09X09
		F 19 902913 - CAVILHA 8X30
		G 06 900053 - BUCHA 08

	H 04 903341 - FIXADOR L CANTONEIRA METÁLICA		K 02 915141 - KIT DOB. SUPER ALTA SLOW C/ 2
	I 04 901635 - FIXADOR L CAPA PLÁSTICA		L 01 905775 - KIT C/ 2 TAPA FURO
	J 10 900456 - FIXADOR P/ FUNDO 4 GARRAS		M 02 913355 - PUXADOR

* LIMITE DE PESO MÁXIMO SUPOSTADO (KG).
* WEIGHT CAPACITY (KG).
* CAPACIDAD DE PESO (KG).

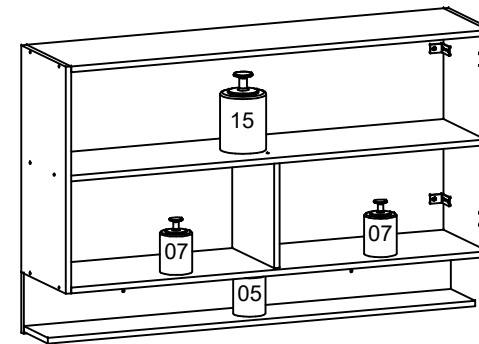

- CONSIDERAR UM PESO BEM DISTRIBUÍDO POR TODO O PRODUTO.
- CONSIDER A WELL DISTRIBUTED WEIGHT IN ALL THE PRODUCT.
- CONSIDERAR UN PESO BIEN DISTRIBUIDO EN TODO EL PRODUCTO.

ESTRUTURA / STRUCTURE / ESTRUCTURA

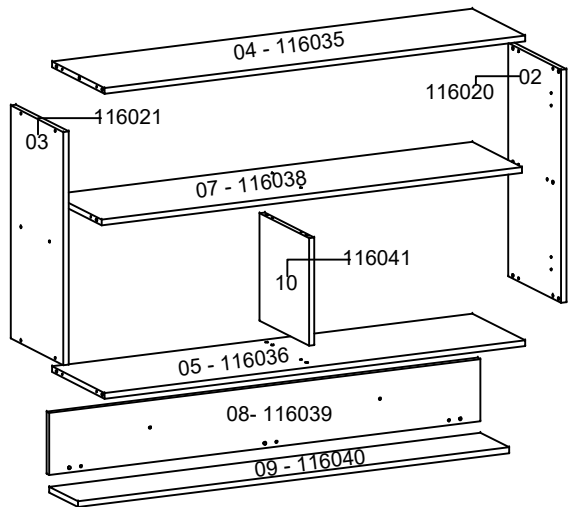

FRENTE / FRONT / FRENTE

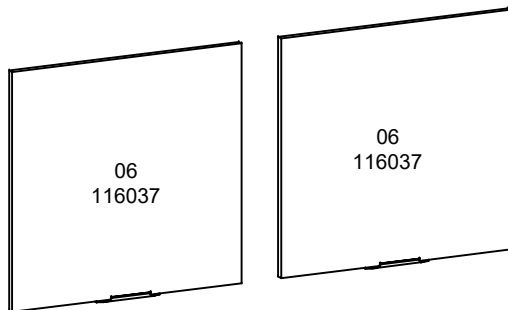

TRASEIRO / BOTTOM / TRASERO

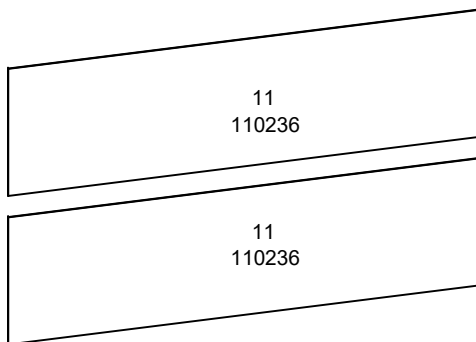

ATENÇÃO / ATTENTION / ATENCIÓN:

- A LIMPEZA DO MÓVEL DEVE SER EFETUADA SOMENTE COM PANO MACIO E MODERADAMENTE UMEDECIDO COM ÁGUA PURA OU SOLUÇÃO COM SABÃO NEUTRO.
- FOR CLEANING, USE ONLY A SOFT CLOTH MODERATELY MOISTENED WITH PURE WATER OR A SOLUTION WITH NEUTRAL SOAP.
- PARA LIMPIEZA DEL MUEBLE USAR UN PAÑO SUAVE Y MODERADAMENTE HUMEDECIDO CON AGUA PURA O SOLUCIÓN CON JABÓN NEUTRO.
- NÃO UTILIZE PRODUTOS QUÍMICOS OU ABRASIVOS, TAIS COMO: CERA, ÁLCOOL, DETERGENTES, TINNER.
- DO NOT USE CHEMICAL OR ABRASIVE PRODUCTS. FOR EXAMPLE: WAX, ALCOHOL, DETERGENT, THINNER.
- NO APLICAR PRODUCTOS QUÍMICOS O ABRASIVOS TALES COMO: CERAS, ALCOHOL, DISOLVENTES O DETERGENTES.
- AO SOLICITAR ASSISTÊNCIA TÉCNICA, INFORME O CÓDIGO DO PRODUTO, A COR E O CÓDIGO DA PEÇA CORRETAMENTE.
- WHEN REQUESTING TECHNICAL ASSISTENCE, INFORM THE PRODUCT CODE, THE COLOR AND THE PIECE CODE CORRECTLY.
- SI NECESITAR REPUESTOS, INFORMAR EL CÓDIGO DEL PRODUCTO, EL COLOR Y EL CÓDIGO DE LA PIEZA.

FERRAMENTAS NECESSÁRIAS P/ MONTAGEM.
 (NÃO SÃO FORNECIDAS)
 REQUIRED TOOLS FOR ASSEMBLY.
 (NOT PROVIDED)
 HERRAMIENTAS NECESARIAS.
 (NO PROPORCIONADAS)



TRENA
Measuring Tape
Cinta Métrica

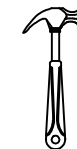

MARTELO
Hammer
Martillo



PARAFUSADEIRA /
FURADEIRA
Screw Gun / Drill
Atornillador / Taladro



CHAVE PHILIPS
Philips Screw Driver
Destornillador Philips



CHAVE DE FENDA
Screw Driver
Destornillador



NÍVEL
Level
Nivel

① COLOCAÇÃO DAS DOBRADIÇAS E PUXADORES.
 HINGE AND HANDLES ATTACHMENT.
 FIJACIÓN DE LAS MANIJAS Y BISAGRA.

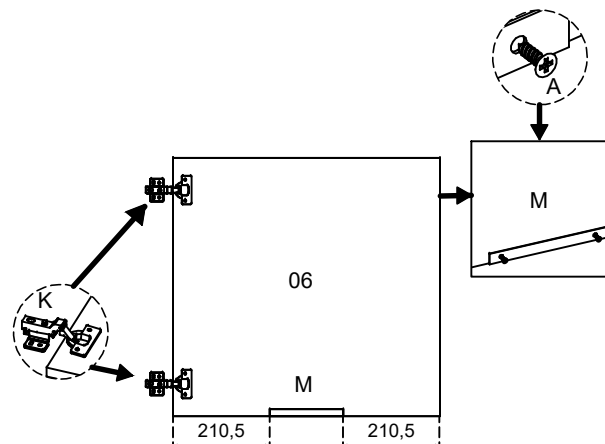

② MONTAGEM DA ESTRUTURA.
 STRUCTURE ASSEMBLY.
 MONTAJE DE LA ESTRUCTURA.

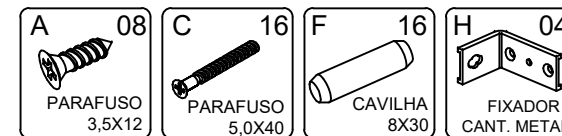
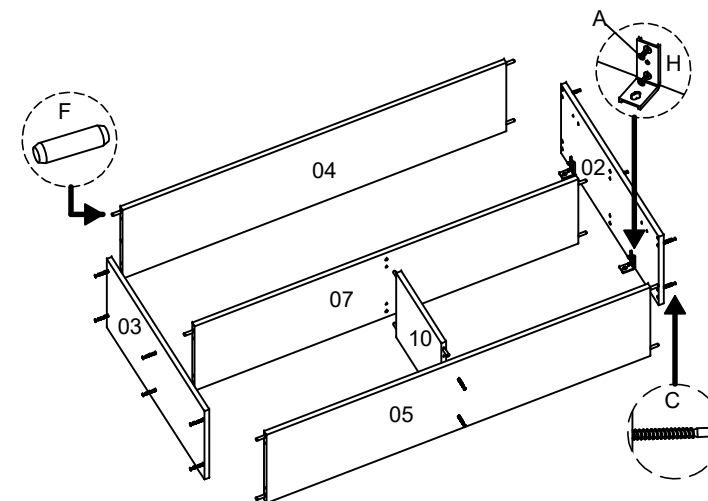

③ MONTAGEM DA PRATELEIRA.
 SHELF ASSEMBLY.
 MONTAJE DE LA REPISA.

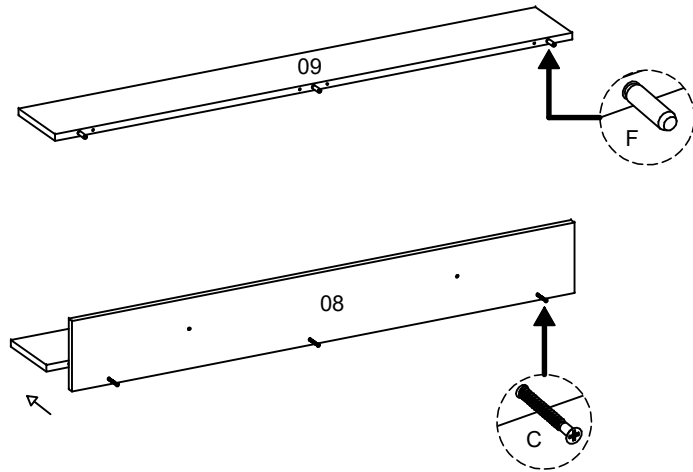
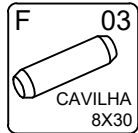

⑤ FIXAÇÃO DO PRODUTO E DA PRATELEIRA NA PAREDE.
 PRODUCT AND SHELF ATTACHMENT ON THE WALL.
 FIJACIÓN DEL PRODUCTO Y REPISA EN LA PARED.

- VERIFICAR O NÍVEL DO PRODUTO.
 - CHECK THE PRODUCT'S LEVELING.
 - VERIFICAR LA NIVELACIÓN DEL PRODUCTO.

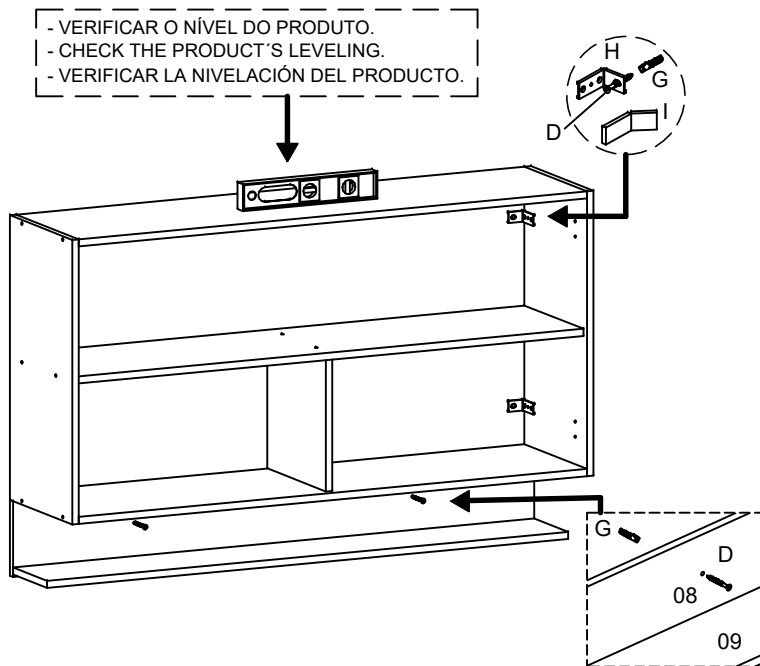

④ FIXAÇÃO DO TRASEIRO.
 BOTTOM ATTACHMENT.
 FIJACIÓN DEL TRASERO.

- TIRAR ESQUADRO: MEDIR EM CRUZ PELOS CANTOS DO PRODUTO.
 - SQUARING: MEASURE THE OPPOSITE CORNERS OF THE PRODUCT IN CROSSWISE.
 - ESCUADRAR: TOMAR LA MEDIDA ENTRE LAS EXTREMIDADES INVERSAS DEL PRODUCTO.

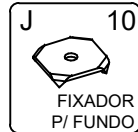
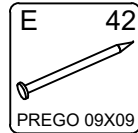
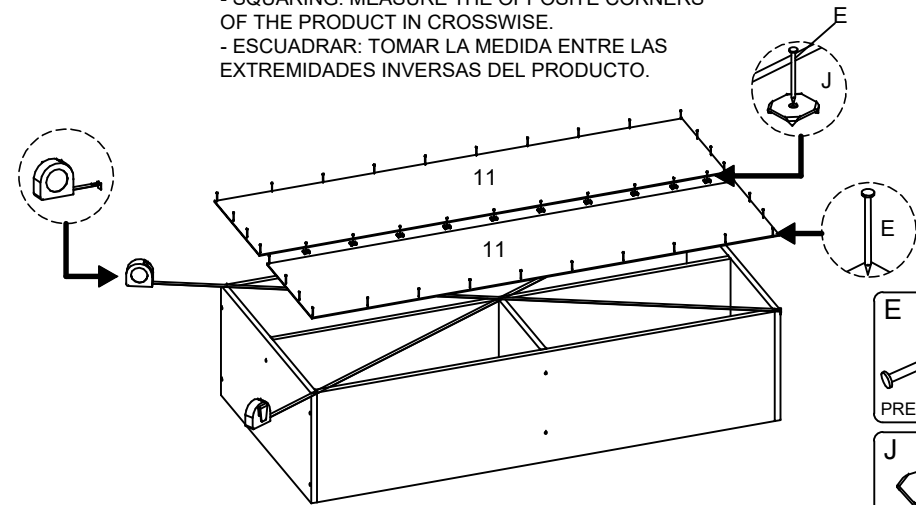

⑥ COLOCAÇÃO DAS PORTAS.
 DOORS PLACEMENT.
 COLOCACIÓN DE LAS PUERTAS.

- PARA UNIÃO DOS MÓDULOS, FAZER USO DO PARAF. 3,5X25 (B).
 - FOR THE MODULES UNION, USE SCREW 3,5X25 (B).
 - PARA LA UNIÓN DE LOS MÓDULOS, USE EL TORNILLO 3,5X25(B).

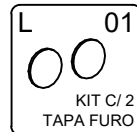
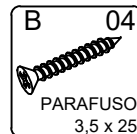
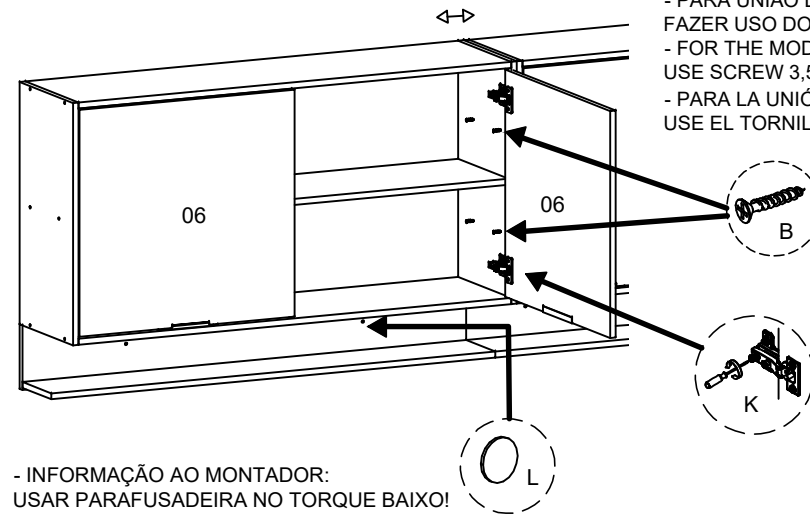

- INFORMAÇÃO AO MONTADOR:
 USAR PARAFUSADEIRA NO TORQUE BAIXO!
 - INFORMATION TO THE ASSEMBLER:
 USE THE CORDLESS DRILL AT LOW TORQUE.
 - INFORMACIÓN AL ARMADOR:
 UTILIZAR ATORNILLADOR EN TORQUE FLACO.